

S34ML08G1 NAND Flash Memory for Embedded

8 Gb, 1-bit ECC, x8 I/O, 3V V_{CC}

Data Sheet (Advance Information)



Notice to Readers: This document states the current technical specifications regarding the Spansion product(s) described herein. Each product described herein may be designated as Advance Information, Preliminary, or Full Production. See [Notice On Data Sheet Designations](#) for definitions.

Notice On Data Sheet Designations

Spansion Inc. issues data sheets with Advance Information or Preliminary designations to advise readers of product information or intended specifications throughout the product life cycle, including development, qualification, initial production, and full production. In all cases, however, readers are encouraged to verify that they have the latest information before finalizing their design. The following descriptions of Spansion data sheet designations are presented here to highlight their presence and definitions.

Advance Information

The Advance Information designation indicates that Spansion Inc. is developing one or more specific products, but has not committed any design to production. Information presented in a document with this designation is likely to change, and in some cases, development on the product may discontinue. Spansion Inc. therefore places the following conditions upon Advance Information content:

“This document contains information on one or more products under development at Spansion Inc. The information is intended to help you evaluate this product. Do not design in this product without contacting the factory. Spansion Inc. reserves the right to change or discontinue work on this proposed product without notice.”

Preliminary

The Preliminary designation indicates that the product development has progressed such that a commitment to production has taken place. This designation covers several aspects of the product life cycle, including product qualification, initial production, and the subsequent phases in the manufacturing process that occur before full production is achieved. Changes to the technical specifications presented in a Preliminary document should be expected while keeping these aspects of production under consideration. Spansion places the following conditions upon Preliminary content:

“This document states the current technical specifications regarding the Spansion product(s) described herein. The Preliminary status of this document indicates that product qualification has been completed, and that initial production has begun. Due to the phases of the manufacturing process that require maintaining efficiency and quality, this document may be revised by subsequent versions or modifications due to changes in technical specifications.”

Combination

Some data sheets contain a combination of products with different designations (Advance Information, Preliminary, or Full Production). This type of document distinguishes these products and their designations wherever necessary, typically on the first page, the ordering information page, and pages with the DC Characteristics table and the AC Erase and Program table (in the table notes). The disclaimer on the first page refers the reader to the notice on this page.

Full Production (No Designation on Document)

When a product has been in production for a period of time such that no changes or only nominal changes are expected, the Preliminary designation is removed from the data sheet. Nominal changes may include those affecting the number of ordering part numbers available, such as the addition or deletion of a speed option, temperature range, package type, or V_{IO} range. Changes may also include those needed to clarify a description or to correct a typographical error or incorrect specification. Spansion Inc. applies the following conditions to documents in this category:

“This document states the current technical specifications regarding the Spansion product(s) described herein. Spansion Inc. deems the products to have been in sufficient production volume such that subsequent versions of this document are not expected to change. However, typographical or specification corrections, or modifications to the valid combinations offered may occur.”

Questions regarding these document designations may be directed to your local sales office.

S34ML08G1 NAND Flash Memory for Embedded

8 Gb, 1-bit ECC, x8 I/O, 3V V_{CC}

Data Sheet (Advance Information)



General Description

The Spansion® S34ML08G1 8-Gb NAND is offered in 3.3 V_{CC} with x8 I/O interface. This document contains information for the S34ML08G1 device, which is a dual-die stack of two S34ML04G1 die. For detailed specifications, please refer to the discrete die data sheet: [S34ML01G1_04G1](#).

Distinctive Characteristics

- **Density**
 - 8 Gb (4 Gb x 2)
- **Architecture (For each 4 Gb device)**
 - Input / Output Bus Width: 8-bits
 - Page Size: (2048 + 64) bytes; 64 bytes is spare area
 - Block Size: 64 Pages or (128k + 4k) bytes
 - Plane Size
 - 2048 Blocks per Plane or (256M + 8M) bytes
 - Device Size
 - 2 Planes per Device or 512 Mbyte
- **NAND Flash Interface**
 - Open NAND Flash Interface (ONFI) 1.0 compliant
 - Address, Data and Commands multiplexed
- **Supply Voltage**
 - 3.3V device: V_{cc} = 2.7V ~ 3.6V
- **Security**
 - One Time Programmable (OTP) area
 - Hardware program/erase disabled during power transition
- **Additional Features**
 - Supports Multiplane Program and Erase commands
 - Supports Copy Back Program
 - Supports Multiplane Copy Back Program
 - Supports Read Cache
- **Electronic Signature**
 - Manufacturer ID: 01h
- **Operating Temperature**
 - Industrial: -40°C to 85°C
 - Automotive: -40°C to 105°C

Performance

- **Page Read / Program**
 - Random access: 25 μ s (Max)
 - Sequential access: 25 ns (Min)
 - Program time / Multiplane Program time: 200 μ s (Typ)
- **Block Erase / Multiplane Erase (S34ML04G1)**
 - Block Erase time: 3.5 ms (Typ)
- **Reliability**
 - 100,000 Program / Erase cycles (Typ)
(with 1 bit / 512 + 16 byte ECC)
 - 10 Year Data retention (Typ)
 - Blocks zero and one are valid and will be valid for at least 1000 program-erase cycles with ECC
- **Package Options**
 - Lead Free and Low Halogen
 - 48-Pin TSOP 12 x 20 x 1.2 mm
 - 63-Ball BGA 9 x 11 x 1 mm

Table of Contents

General Description	3
Distinctive Characteristics	3
Performance	3
1. Connection Diagram	5
2. Pin Description	7
3. Block Diagrams	7
4. Addressing	9
5. Read Status Enhanced	9
6. Extended Read Status	9
7. Read ID	10
7.1 Read Parameter Page	11
8. Electrical Characteristics	13
8.1 Valid Blocks	13
8.2 DC Characteristics	14
8.3 Pin Capacitance	14
8.4 Power Consumptions and Pin Capacitance for Allowed Stacking Configurations	14
9. Physical Interface	15
9.1 Physical Diagram	15
10. Ordering Information	17
11. Appendix A — Errata	18
12. Revision History	19

1. Connection Diagram

Figure 1.1 48-Pin TSOP1 Contact x8 Device (1 CE 8 Gb)

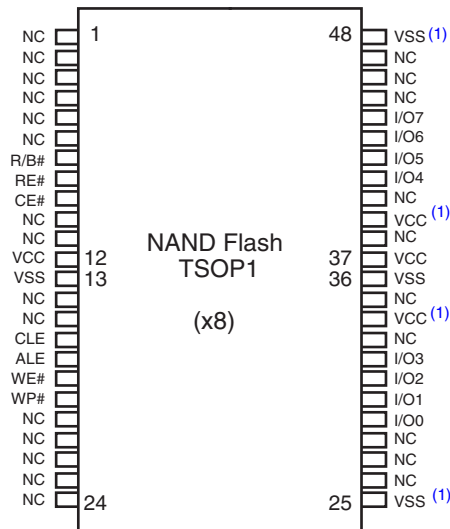

Note:

1. These pins should be connected to power supply or ground (as designated) following the ONFI specification, however they might not be bonded internally.

Figure 1.2 48-Pin TSOP1 Contact x8 Device (2 CE 8 Gb)

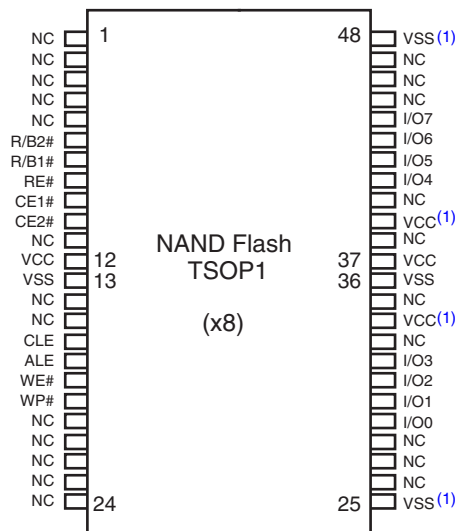

Note:

1. These pins should be connected to power supply or ground (as designated) following the ONFI specification, however they might not be bonded internally.

Figure 1.3 63-BGA Contact, x8 Device, Single CE (Top View)

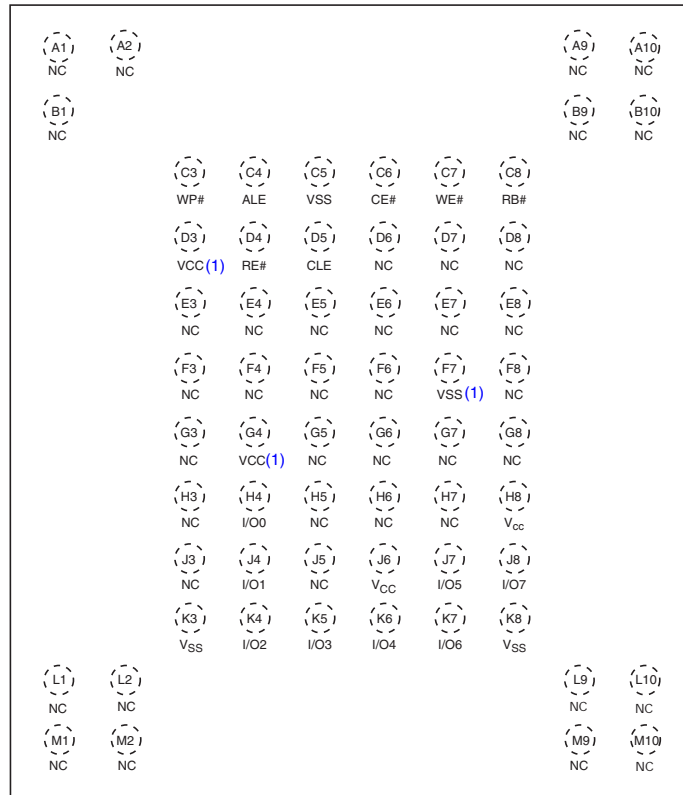

Note:

1. These pins should be connected to power supply or ground (as designated) following the ONFI specification, however they might not be bonded internally.

2. Pin Description

Table 2.1 Pin Description

Pin Name	Description
I/O0 - I/O7	Inputs/Outputs. The I/O pins are used for command input, address input, data input, and data output. The I/O pins float to High-Z when the device is deselected or the outputs are disabled.
CLE	Command Latch Enable. This input activates the latching of the I/O inputs inside the Command Register on the rising edge of Write Enable (WE#).
ALE	Address Latch Enable. This input activates the latching of the I/O inputs inside the Address Register on the rising edge of Write Enable (WE#).
CE#	Chip Enable. This input controls the selection of the device. When the device is not busy CE# low selects the memory.
WE#	Write Enable. This input latches Command, Address and Data. The I/O inputs are latched on the rising edge of WE#.
RE#	Read Enable. The RE# input is the serial data-out control, and when active drives the data onto the I/O bus. Data is valid t_{REA} after the falling edge of RE# which also increments the internal column address counter by one.
WP#	Write Protect. The WP# pin, when low, provides hardware protection against undesired data modification (program / erase).
R/B#	Ready Busy. The Ready/Busy output is an Open Drain pin that signals the state of the memory.
VCC	Supply Voltage. The VCC supplies the power for all the operations (Read, Program, Erase). An internal lock circuit prevents the insertion of Commands when VCC is less than V _{LKO} .
VSS	Ground.
NC	Not Connected.

Notes:

1. A 0.1 μ F capacitor should be connected between the VCC Supply Voltage pin and the VSS Ground pin to decouple the current surges from the power supply. The PCB track widths must be sufficient to carry the currents required during program and erase operations.
2. An internal voltage detector disables all functions whenever VCC is below 1.8V to protect the device from any involuntary program/erase during power transitions.

3. Block Diagrams

Figure 3.1 Functional Block Diagram — 4 Gb

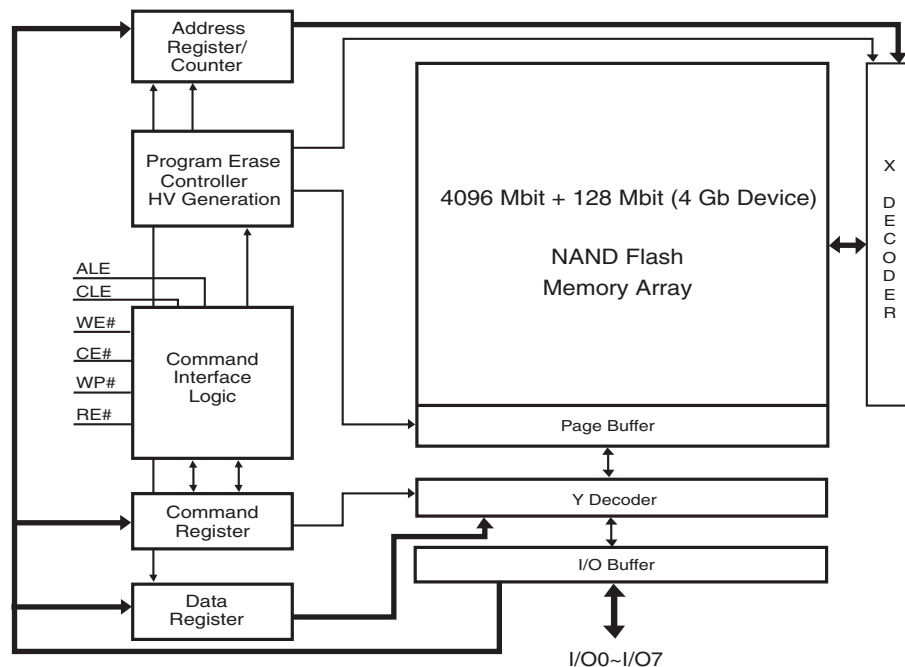

Figure 3.2 Block Diagram — 1 CE (4 Gb x 8)

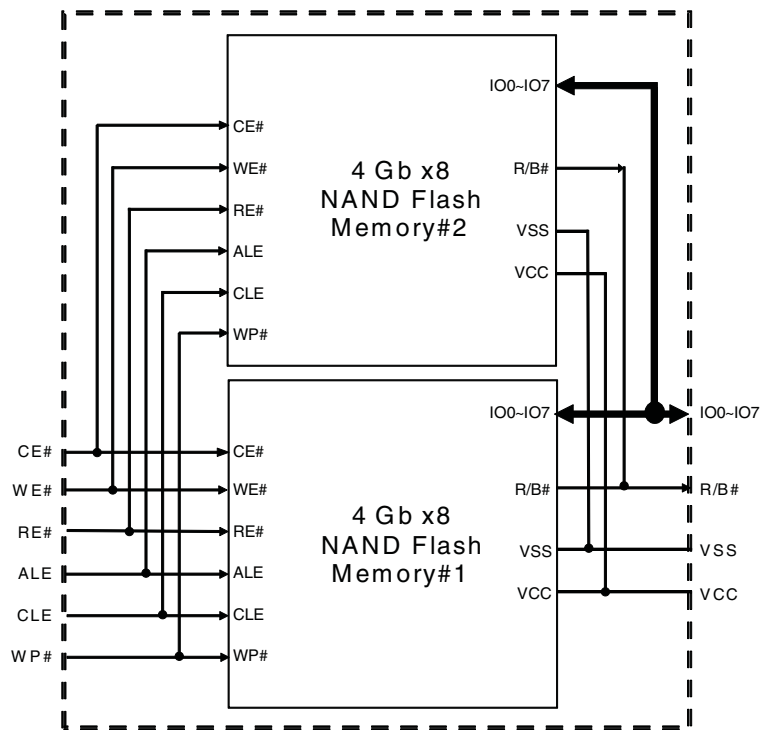
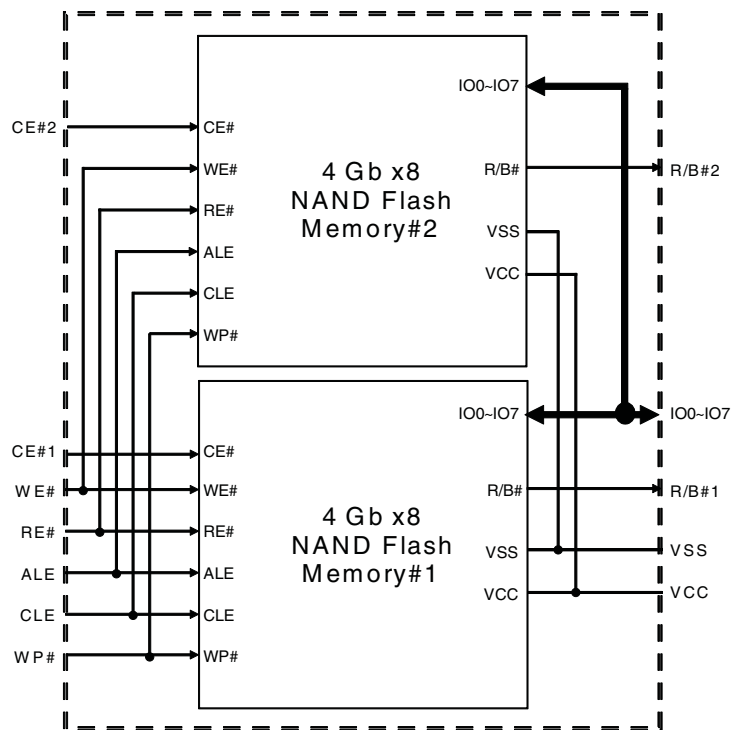

Figure 3.3 Block Diagram — 2 CE (4 Gb x 8)



4. Addressing

Table 4.1 Address Cycle Map

Bus Cycle	I/O0	I/O1	I/O2	I/O3	I/O4	I/O5	I/O6	I/O7
1st / Col. Add. 1	A0 (CA0)	A1 (CA1)	A2 (CA2)	A3 (CA3)	A4 (CA4)	A5 (CA5)	A6 (CA6)	A7 (CA7)
2nd / Col. Add. 2	A8 (CA8)	A9 (CA9)	A10 (CA10)	A11 (CA11)	Low	Low	Low	Low
3rd / Row Add. 1	A12 (PA0)	A13 (PA1)	A14 (PA2)	A15 (PA3)	A16 (PA4)	A17 (PA5)	A18 (PLA0)	A19 (BA0)
4th / Row Add. 2	A20 (BA1)	A21 (BA2)	A22 (BA3)	A23 (BA4)	A24 (BA5)	A25 (BA6)	A26 (BA7)	A27 (BA8)
5th / Row Add. 3 (6)	A28 (BA9)	A29 (BA10)	A30 (BA11)	Low	Low	Low	Low	Low

Notes:

1. CAx = Column Address bit.
2. PAx = Page Address bit.
3. PLA0 = Plane Address bit zero.
4. BAx = Block Address bit.
5. Block address concatenated with page address and plane address = actual page address, also known as the row address.
6. A30 for 8 Gb (4 Gb x 2 – DDP) (1CE).

For the address bits, the following rules apply:

- A0 - A11: column address in the page
- A12 - A17: page address in the block
- A18: plane address (for multiplane operations) / block address (for normal operations)
- A19 - A30: block address

5. Read Status Enhanced

Read Status Enhanced is used to retrieve the status value for a previous operation in the following cases:

- In the case of concurrent operations on a multi-die stack.

When two dies are stacked to form a dual-die package (DDP), it is possible to run one operation on the first die, then activate a different operation on the second die, for example: Erase while Read, Read while Program, etc.

- In the case of multiplane operations in the same die.

6. Extended Read Status

Multi-die stack devices support the Extended Read Status operation. When two operations are active in separate dies at the same time, this feature allows the host to check the status of a given die. For example, the first die could be executing a Page Program while the second die is performing a Page Read. Refer to [Table 6.1](#) for a description of each command.

Table 6.1 Extended Read Status

Command	Die	Row Address with 4 Gb Dies
F2h	First	0 to 3FFFFh
F3h	Second	40000h to 7FFFFh

7. Read ID

The device contains a product identification mode, initiated by writing 90h to the command register, followed by an address input of 00h.

Note: If you want to execute Read Status command (0x70) after Read ID sequence, you should input dummy command (0x00) before Read Status command (0x70).

For the S34ML04G1 device, five read cycles sequentially output the manufacturer code (01h), and the device code and 3rd, 4th, and 5th cycle ID, respectively. The command register remains in Read ID mode until further commands are issued to it.

Table 7.1 Read ID for Supported Configurations (1)

Density	Org	V _{CC}	1st	2nd	3rd	4th	5th
4 Gb	x8	3.3V	01h	DCh	90h	95h	54h
8 Gb (4 Gb x 2 – DDP with two CE#)	x8	3.3V	01h	DCh	90h	95h	54h
8 Gb (4 Gb x 2 – DDP with one CE#) (1)	x8	3.3V	01h	D3h	D1h	95h	58h

Note:

1. See [See Appendix A — Errata on page 18](#) for information on READ ID in MCPs.

Figure 7.1 Read ID Operation Timing — 8 Gb

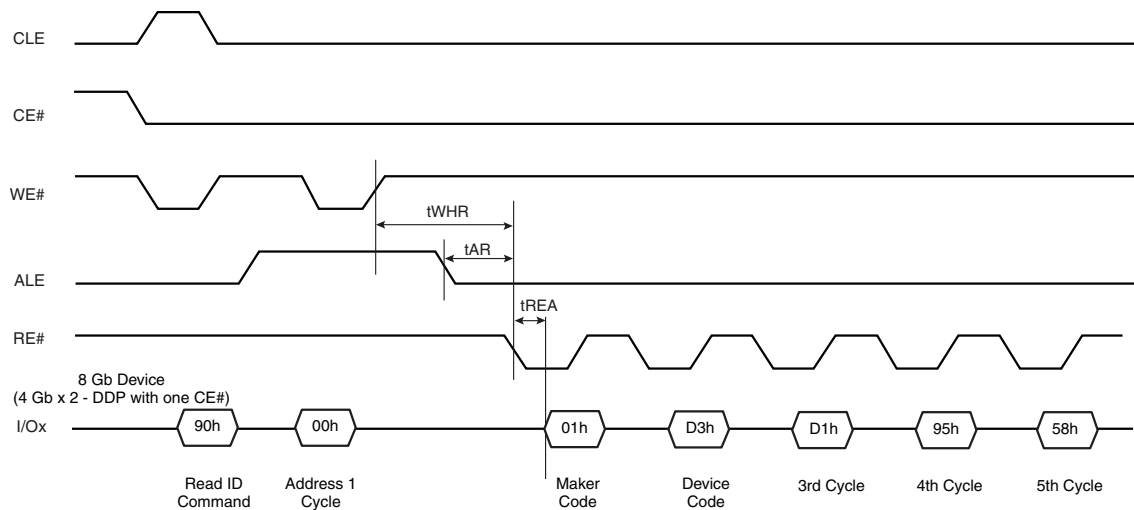

5th ID Data

Table 7.2 Read ID Byte 5 Description — S34ML04G1

	Description	I/O7	I/O6 I/O5 I/O4	I/O3 I/O2	I/O1	I/O0
Plane Number	1			0 0		
	2			0 1		
	4			1 0		
	8			1 1		
Plane Size (without spare area)	64 Mb		0 0 0			
	128 Mb		0 0 1			
	256 Mb		0 1 0			
	512 Mb		0 1 1			
	1 Gb		1 0 0			
	2 Gb		1 0 1			
	4 Gb		1 1 0			
8 Gb		1 1 1				
Reserved		0			0	0

7.1 Read Parameter Page

The device supports the ONFI Read Parameter Page operation, initiated by writing ECh to the command register, followed by an address input of 00h. The command register remains in Parameter Page mode until further commands are issued to it. [Table 7.3](#) explains the parameter fields.

Table 7.3 Parameter Page Description (Sheet 1 of 3)

Byte	O/M	Description	Values
Revision Information and Features Block			
0-3	M	Parameter page signature Byte 0: 4Fh, "O" Byte 1: 4Eh, "N" Byte 2: 46h, "F" Byte 3: 49h, "I"	4Fh, 4Eh, 46h, 49h
4-5	M	Revision number 2-15 Reserved (0) 1 1 = supports ONFI version 1.0 0 Reserved (0)	02h, 00h
6-7	M	Features supported 5-15 Reserved (0) 4 1 = supports odd to even page Copyback 3 1 = supports interleaved operations 2 1 = supports non-sequential page programming 1 1 = supports multiple LUN operations 0 1 = supports 16-bit data bus width	1Eh, 00h
8-9	M	Optional commands supported 6-15 Reserved (0) 5 1 = supports Read Unique ID 4 1 = supports Copyback 3 1 = supports Read Status Enhanced 2 1 = supports Get Features and Set Features 1 1 = supports Read Cache commands 0 1 = supports Page Cache Program command	1Bh, 00h
10-31		Reserved (0)	00h
Manufacturer Information Block			
32-43	M	Device manufacturer (12 ASCII characters)	53h, 50h, 41h, 4Eh, 53h, 49h, 4Fh, 4Eh, 20h, 20h, 20h, 20h
44-63	M	Device model (20 ASCII characters)	53h, 33h, 34h, 4Dh, 4Ch, 30h, 38h, 47h, 31h, 20h, 20h, 20h, 20h, 20h, 20h, 20h, 20h, 20h, 20h, 20h
64	M	JEDEC manufacturer ID	01h

Table 7.3 Parameter Page Description (Sheet 2 of 3)

Byte	O/M	Description	Values
65-66	O	Date code	00h
67-79		Reserved (0)	00h
Memory Organization Block			
80-83	M	Number of data bytes per page	00h, 08h, 00h, 00h
84-85	M	Number of spare bytes per page	40h, 00h
86-89	M	Number of data bytes per partial page	00h, 02h, 00h, 00h
90-91	M	Number of spare bytes per partial page	10h, 00h
92-95	M	Number of pages per block	40h, 00h, 00h, 00h
96-99	M	Number of blocks per logical unit (LUN)	00h, 10h, 00h, 00h
100	M	Number of logical units (LUNs)	02h
101	M	Number of address cycles 4-7 Column address cycles 0-3 Row address cycles	23h
102	M	Number of bits per cell	01h
103-104	M	Bad blocks maximum per LUN	50h, 00h
105-106	M	Block endurance	01h, 05h
107	M	Guaranteed valid blocks at beginning of target	01h
108-109	M	Block endurance for guaranteed valid blocks	01h, 03h
110	M	Number of programs per page	04h
111	M	Partial programming attributes 5-7 Reserved 4 1 = partial page layout is partial page data followed by partial page spare 1-3 Reserved 0 1 = partial page programming has constraints	00h
112	M	Number of bits ECC correctability	01h
113	M	Number of interleaved address bits 4-7 Reserved (0) 0-3 Number of interleaved address bits	01h
114	O	Interleaved operation attributes 4-7 Reserved (0) 3 Address restrictions for program cache 2 1 = program cache supported 1 1 = no block address restrictions 0 Overlapped / concurrent interleaving support	04h
115-127		Reserved (0)	00h
Electrical Parameters Block			
128	M	I/O pin capacitance	0Ah
129-130	M	Timing mode support 6-15 Reserved (0) 5 1 = supports timing mode 5 4 1 = supports timing mode 4 3 1 = supports timing mode 3 2 1 = supports timing mode 2 1 1 = supports timing mode 1 0 1 = supports timing mode 0, shall be 1	1Fh, 00h
131-132	O	Program cache timing mode support 6-15 Reserved (0) 5 1 = supports timing mode 5 4 1 = supports timing mode 4 3 1 = supports timing mode 3 2 1 = supports timing mode 2 1 1 = supports timing mode 1 0 1 = supports timing mode 0	1Fh, 00h
133-134	M	t _{PROG} Maximum page program time (μs)	BCh, 02h
135-136	M	t _{BERS} Maximum block erase time (μs)	10h, 27h
137-138	M	t _R Maximum page read time (μs)	19h, 00h
139-140	M	t _{CCS} Minimum Change Column setup time (ns)	64h, 00h

Table 7.3 Parameter Page Description (Sheet 3 of 3)

Byte	O/M	Description	Values
141-163		Reserved (0)	00h
Vendor Block			
164-165	M	Vendor specific Revision number	00h
166-253		Vendor specific	00h
254-255	M	Integrity CRC	7Bh, 09h
Redundant Parameter Pages			
256-511	M	Value of bytes 0-255	Repeat Value of bytes 0-255
512-767	M	Value of bytes 0-255	Repeat Value of bytes 0-255
768+	O	Additional redundant parameter pages	FFh

Note:

1. "O" Stands for Optional, "M" for Mandatory.

8. Electrical Characteristics

8.1 Valid Blocks

Table 8.1 Valid Blocks — 4 Gb

Device	Symbol	Min	Typ	Max	Unit
S34ML04G1	N _{VB}	4016	—	4096	Blocks
S34ML08G1	N _{VB}	8032 (1)	—	8192	Blocks

Note:

1. Each 4 Gb has maximum 80 bad blocks.

8.2 DC Characteristics

Table 8.2 DC Characteristics and Operating Conditions
(Values listed are for each 4 Gb NAND, 8 Gb (4 Gb x 2) will be additive accordingly)

Parameter	Symbol	Test Conditions	Min	Typ	Max	Units	
Power-On Current	I_{CC0}	Power up Current	—	15	30	mA	
Operating Current	Sequential Read	I_{CC1} $t_{RC} = t_{RC}(\text{min}), CE\# = V_{IL}, I_{OUT} = 0 \text{ mA}$	—	15	30	mA	
	Program	I_{CC2}	Normal	—	—	30	mA
		Cache	—	—	—	40	mA
Erase	I_{CC3}	—	—	15	30	mA	
Standby current, (TTL)	I_{CC4}	$CE\# = V_{IH}, WP\# = 0V/V_{CC}$	—	—	1	mA	
Standby current, (CMOS)	I_{CC5}	$CE\# = V_{CC}-0.2, WP\# = 0/V_{CC}$	—	10	50	μA	
Input Leakage Current	I_{LI}	$V_{IN} = 0 \text{ to } 3.6\text{V}$	—	—	± 10	μA	
Output Leakage Current	I_{LO}	$V_{OUT} = 0 \text{ to } 3.6\text{V}$	—	—	± 10	μA	
Input High Voltage	V_{IH}	—	$V_{CC} \times 0.8$	—	$V_{CC} + 0.3$	V	
Input Low Voltage	V_{IL}	—	-0.3	—	$V_{CC} \times 0.2$	V	
Output High Voltage	V_{OH}	$I_{OH} = -400 \mu\text{A}$	2.4	—	—	V	
Output Low Voltage	V_{OL}	$I_{OL} = 2.1 \text{ mA}$	—	—	0.4	V	
Output Low Current (R/B#)	$I_{OL(R/B\#)}$	$V_{OL} = 0.4\text{V}$	8	10	—	mA	
V_{CC} Supply Voltage (erase and program lockout)	V_{LKO}	—	—	1.8	—	V	

Notes:

1. All V_{CCQ} and V_{CC} pins, and V_{SS} and V_{SSQ} pins respectively are shorted together.
2. Values listed in this table refer to the complete voltage range for V_{CC} and V_{CCQ} and to a single device in case of device stacking.
3. All current measurements are performed with a 0.1 μF capacitor connected between the V_{CC} Supply Voltage pin and the V_{SS} Ground pin.
4. Standby current measurement can be performed after the device has completed the initialization process at power-up.

8.3 Pin Capacitance

Table 8.3 Pin Capacitance (TA = 25°C, f=1.0 MHz)

Parameter	Symbol	Test Condition	Min	Max	Unit
Input	C_{IN}	$V_{IN} = 0\text{V}$	—	10	pF
Input / Output	C_{IO}	$V_{IL} = 0\text{V}$	—	10	pF

Note:

1. For the stacked devices version the Input is 10 pF x [number of stacked chips] and the Input/Output is 10 pF x [number of stacked chips].

8.4 Power Consumptions and Pin Capacitance for Allowed Stacking Configurations

When multiple dies are stacked in the same package, the power consumption of the stack will increase according to the number of chips. As an example, the standby current is the sum of the standby currents of all the chips, while the active power consumption depends on the number of chips concurrently executing different operations.

When multiple dies are stacked in the same package the pin/ball capacitance for the single input and the single input/output of the combo package must be calculated based on the number of chips sharing that input or that pin/ball.

9. Physical Interface

9.1 Physical Diagram

9.1.1 48-Pin Thin Small Outline Package (TSOP1)

Figure 9.1 TS2 48 — 48-lead Plastic Thin Small Outline, 12 x 20 mm, Package Outline

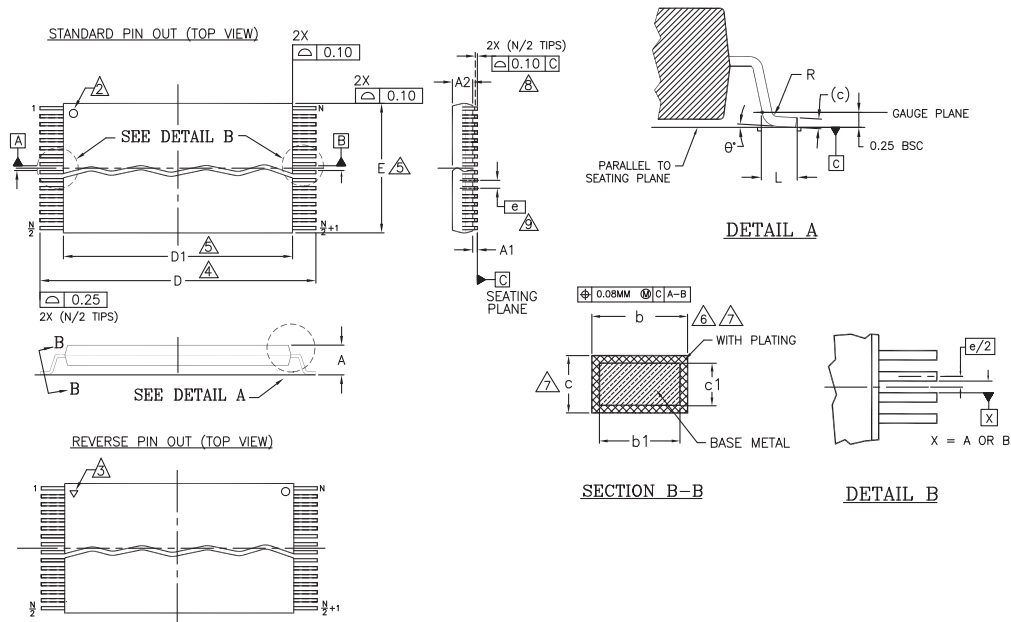

PACKAGE	TS2 48		
JEDEC	MO-142 (D) DD		
SYMBOL	MIN	NOM	MAX
A	---	---	1.20
A1	0.05	---	0.15
A2	0.95	1.00	1.05
b1	0.17	0.20	0.23
b	0.17	0.22	0.27
c1	0.10	---	0.16
c	0.10	---	0.21
D	19.80	20.00	20.20
D1	18.30	18.40	18.50
E	11.90	12.00	12.10
e	0.50 BASIC		
L	0.50	0.60	0.70
θ	0°	---	8
R	0.08	---	0.20
N	48		

NOTES:

1. DIMENSIONS ARE IN MILLIMETERS (mm). (DIMENSIONING AND TOLERANCING CONFORM TO ANSI Y14.5M-1994).
2. PIN 1 IDENTIFIER FOR STANDARD PIN OUT (DIE UP).
3. PIN 1 IDENTIFIER FOR REVERSE PIN OUT (DIE DOWN); INK OR LASER MARK.
4. TO BE DETERMINED AT THE SEATING PLANE [C-]. THE SEATING PLANE IS DEFINED AS THE PLANE OF CONTACT THAT IS MADE WHEN THE PACKAGE LEADS ARE ALLOWED TO REST FREELY ON A FLAT HORIZONTAL SURFACE.
5. DIMENSIONS D1 AND E DO NOT INCLUDE MOLD PROTRUSION. ALLOWABLE MOLD PROTRUSION ON E IS 0.15mm PER SIDE AND ON D1 IS 0.25mm PER SIDE.
6. DIMENSION b DOES NOT INCLUDE DAMBAR PROTRUSION. ALLOWABLE DAMBAR PROTRUSION SHALL BE 0.08mm TOTAL IN EXCESS OF b DIMENSION AT MAX. MATERIAL CONDITION. DAMBAR CANNOT BE LOCATED ON LOWER RADIUS OR THE FOOT. MINIMUM SPACE BETWEEN PROTRUSION AND AN ADJACENT LEAD TO BE 0.07mm.
7. THESE DIMENSIONS APPLY TO THE FLAT SECTION OF THE LEAD BETWEEN 0.10mm AND 0.25mm FROM THE LEAD TIP.
8. LEAD COPLANARITY SHALL BE WITHIN 0.10mm AS MEASURED FROM THE SEATING PLANE.
9. DIMENSION "e" IS MEASURED AT THE CENTERLINE OF THE LEADS.

5007 \ f16-038 \ 6.5.13

9.1.2 63-Pin Ball Grid Array (BGA)

Figure 9.2 VLD063 — 63-Pin BGA, 11 mm x 9 mm Package

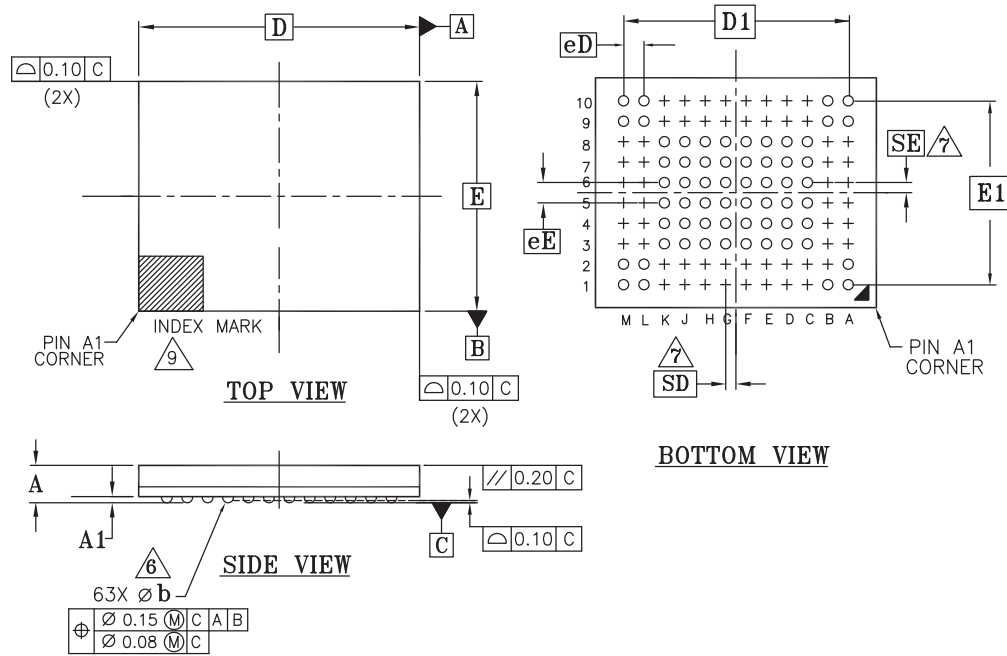

PACKAGE	VLD 063			NOTE
JEDEC	MO-207(M)			
	11.00 mm x 9.00 mm PACKAGE			
SYMBOL	MIN	NOM	MAX	
A	---	---	1.00	PROFILE
A1	0.25	---	---	BALL HEIGHT
D	11.00 BSC.			BODY SIZE
E	9.00 BSC.			BODY SIZE
D1	8.80 BSC.			MATRIX FOOTPRINT
E1	7.20 BSC.			MATRIX FOOTPRINT
MD	12			MATRIX SIZE D DIRECTION
ME	10			MATRIX SIZE E DIRECTION
n	63			BALL COUNT
ø b	0.40	0.45	0.50	BALL DIAMETER
eE	0.80 BSC.			BALL PITCH
eD	0.80 BSC.			BALL PITCH
SD	0.40 BSC.			SOLDER BALL PLACEMENT
SE	0.40 BSC.			SOLDER BALL PLACEMENT
	A3-A8, B2-B8, C1, C2, C9, C10, D1, D2, D9, D10, E1, E2, E9, E10, F1, F2, F9, F10, G1, G2, G9, G10, H1, H2, H9, H10, J1, J2, J9, J10, K1, K2, K9, K10, L3-L8, M3-M8			DEPOPULATED SOLDER BALLS

NOTES:

- DIMENSIONING AND TOLERANCING METHODS PER ASME Y14.5M-1994.
- ALL DIMENSIONS ARE IN MILLIMETERS.
- BALL POSITION DESIGNATION PER JEP95, SECTION 3, SPP-020.
- \square REPRESENTS THE SOLDER BALL GRID PITCH.
- SYMBOL "MD" IS THE BALL MATRIX SIZE IN THE "D" DIRECTION.
SYMBOL "ME" IS THE BALL MATRIX SIZE IN THE "E" DIRECTION.
n IS THE TOTAL NUMBER OF POPULATED SOLDER BALL POSITIONS FOR MATRIX SIZE MD X ME.
- $\triangle 6$ DIMENSION "b" IS MEASURED AT THE MAXIMUM BALL DIAMETER IN A PLANE PARALLEL TO DATUM C.
- $\triangle 7$ "SD" AND "SE" ARE MEASURED WITH RESPECT TO DATUMS A AND B AND DEFINE THE POSITION OF THE CENTER SOLDER BALL IN THE OUTER ROW.
WHEN THERE IS AN ODD NUMBER OF SOLDER BALLS IN THE OUTER ROW "SD" OR "SE" = 0.
WHEN THERE IS AN EVEN NUMBER OF SOLDER BALLS IN THE OUTER ROW, "SD" = eD/2 AND "SE" = eE/2.
- "*" INDICATES THE THEORETICAL CENTER OF DEPOPULATED BALLS.
- $\triangle 9$ A1 CORNER TO BE IDENTIFIED BY CHAMFER, LASER OR INK MARK, METALLIZED MARK INDENTATION OR OTHER MEANS.

g5013 | 16-038.28 | 6.5.13

10. Ordering Information

The ordering part number is formed by a valid combination of the following:

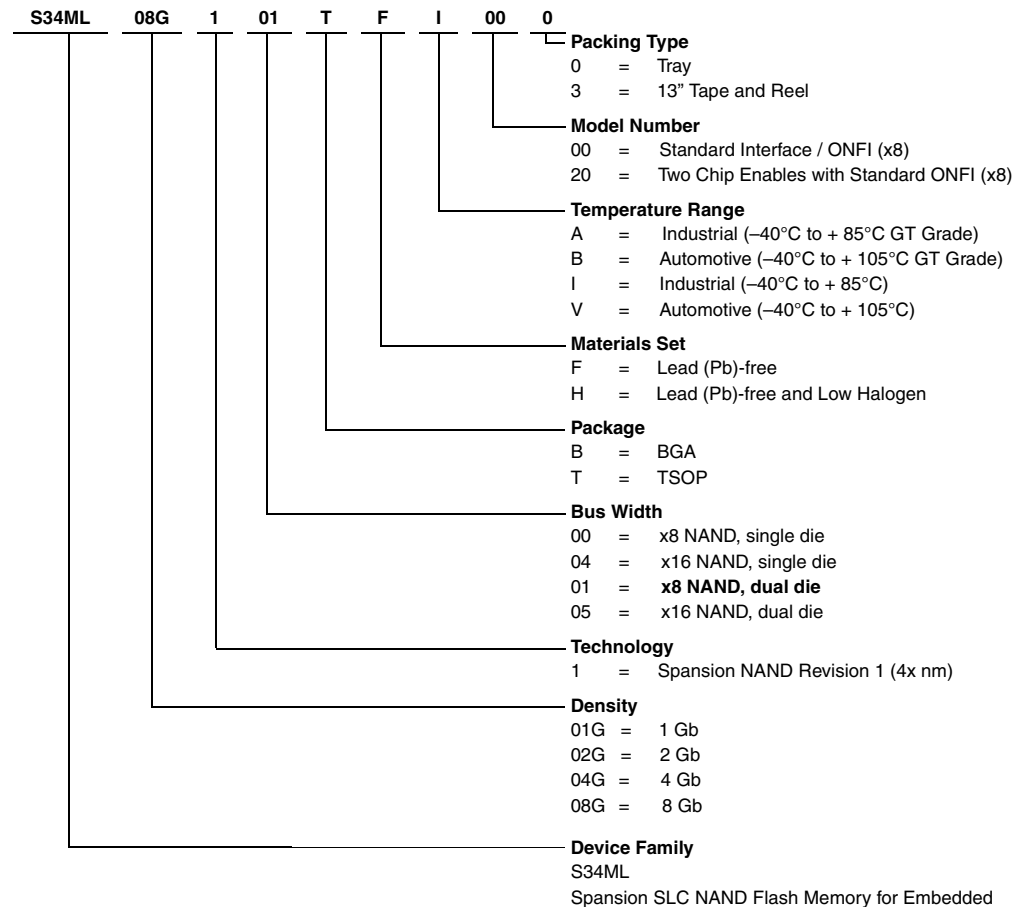

Valid Combinations

Valid Combinations list configurations planned to be supported in volume for this device. Consult your local sales office to confirm availability of specific valid combinations and to check on newly released combinations.

Valid Combinations								
Device Family	Density	Technology	Bus Width	Package Type	Temperature Range	Additional Ordering Options	Packing Type	Package Description
S34ML	08G	1	01	TF	A, B, I, V	00, 20	0, 3	TSOP
				BH		00		BGA (1)

Note:

1. BGA package marking omits the leading "S34" and the Packing Type designator from the ordering part number.

11. Appendix A — Errata

For Spansion NAND MCPs (Multi-Chip Package) like the 8 Gb (2 x 4 Gb), due to the internal bonding, READ ID automatically changes to the hard-wired values and currently there is no way to change it electrically. Therefore, the Spansion NAND 8 Gb with one CE# will not follow the same methodology of READ ID as SDPs (Single Die Package). The READ ID values for the 8-Gb Spansion NAND with one CE# will be as follows:

1st Byte: 01h

2nd Byte: D3h

3rd Byte: D1h

4th Byte: 95h

5th Byte: 58h

	1st Byte	2nd Byte	3rd Byte	4th Byte	5th Byte
8 Gb with one CE# (Currently with error)	01h	D3h	D1h	95h	58h
8 Gb with one CE# (Spansion methodology)	01h	DCh	91h	95h	54h

Currently, Spansion does not plan to fix the problem. If there are any issues related to this, please contact Spansion NAND Product Marketing for further questions.

12. Revision History

Section	Description
Revision 01 (August 23, 2012)	
	Initial release
Revision 02 (October 1, 2012)	
Addressing	Address Cycle Map table: corrected data
Read ID	Read ID for Supported Configurations table: added row – 8 Gb (4 Gb x 2 – DDP with two CE#)
Read Parameter Page	Parameter Page Description table: corrected Electrical Parameters Block values for bytes 129-130 and bytes 131-132 corrected Vendor Block values for bytes 254-255
Appendix A	Added text
Revision 03 (November 29, 2012)	
Ordering Information	Added Model Number
Revision 04 (December 19, 2012)	
Read Parameter Page	Parameter Page Description table: corrected Description for Bytes 129-130 and bytes 131-132
DC Characteristics	DC Characteristics and Operating Conditions table: corrected Test Conditions for I_{CC1} Output High Voltage: removed $I_{OH} = 100 \mu A$ row Output Low Voltage: removed $I_{OL} = 100 \mu A$ row Output Low Current (R/B#): removed $V_{OL} = 0.1V$ row
Ordering Information	Valid Combinations table: removed Bus Width 05
Revision 05 (August 9, 2013)	
Distinctive Characteristics	Security: Removed Serial number (unique ID) Operating Temperature: removed Commercial and Extended temperatures
Performance	Updated Reliability
Connection Diagram	Added figure: 48-Pin TSOP1 Contact x8 Device (1 CE 8 Gb)
Addressing	Address Cycle Map table: appended Note Added text to Bus Cycle column
Extended Read Status	Extended Read Status table: removed Commands F4h and F5h
Read Parameter Page	Parameter Page Description table: corrected Byte 44-63, 100, and 254-255 Values
Valid Blocks	Valid Blocks table: clarified Device values
DC Characteristics	DC Characteristics and Operating Conditions table: added row, ' V_{CC} Supply Voltage'
Physical Interface	Updated figures: TS2 48 — 48-lead Plastic Thin Small Outline, 12 x 20 mm, Package Outline VLD063 — 63-Pin BGA, 11 mm x 9 mm Package
Ordering Information	Updated Materials Set: H = Low Halogen to H = Lead (Pb)-free and Low Halogen Valid Combinations table: removed 04G; Added Note
Revision 06 (April 1, 2014)	
Ordering Information	Updated Temperature Range to include A (-40°C to 85°C GT Grade), B (-40°C to 105°C GT Grade), and V (-40°C to 105°C) Valid Combinations table: added A, B, V to Temperature Range

Colophon

The products described in this document are designed, developed and manufactured as contemplated for general use, including without limitation, ordinary industrial use, general office use, personal use, and household use, but are not designed, developed and manufactured as contemplated (1) for any use that includes fatal risks or dangers that, unless extremely high safety is secured, could have a serious effect to the public, and could lead directly to death, personal injury, severe physical damage or other loss (i.e., nuclear reaction control in nuclear facility, aircraft flight control, air traffic control, mass transport control, medical life support system, missile launch control in weapon system), or (2) for any use where chance of failure is intolerable (i.e., submersible repeater and artificial satellite). Please note that Spansion will not be liable to you and/or any third party for any claims or damages arising in connection with above-mentioned uses of the products. Any semiconductor devices have an inherent chance of failure. You must protect against injury, damage or loss from such failures by incorporating safety design measures into your facility and equipment such as redundancy, fire protection, and prevention of over-current levels and other abnormal operating conditions. If any products described in this document represent goods or technologies subject to certain restrictions on export under the Foreign Exchange and Foreign Trade Law of Japan, the US Export Administration Regulations or the applicable laws of any other country, the prior authorization by the respective government entity will be required for export of those products.

Trademarks and Notice

The contents of this document are subject to change without notice. This document may contain information on a Spansion product under development by Spansion. Spansion reserves the right to change or discontinue work on any product without notice. The information in this document is provided as is without warranty or guarantee of any kind as to its accuracy, completeness, operability, fitness for particular purpose, merchantability, non-infringement of third-party rights, or any other warranty, express, implied, or statutory. Spansion assumes no liability for any damages of any kind arising out of the use of the information in this document.

Copyright © 2012-2014 Spansion Inc. All rights reserved. Spansion®, the Spansion logo, MirrorBit®, MirrorBit® Eclipse™, ORNAND™ and combinations thereof, are trademarks and registered trademarks of Spansion LLC in the United States and other countries. Other names used are for informational purposes only and may be trademarks of their respective owners.



Компания «ЭлектроПласт» предлагает заключение долгосрочных отношений при поставках импортных электронных компонентов на взаимовыгодных условиях!

Наши преимущества:

- Оперативные поставки широкого спектра электронных компонентов отечественного и импортного производства напрямую от производителей и с крупнейших мировых складов;
- Поставка более 17-ти миллионов наименований электронных компонентов;
- Поставка сложных, дефицитных, либо снятых с производства позиций;
- Оперативные сроки поставки под заказ (от 5 рабочих дней);
- Экспресс доставка в любую точку России;
- Техническая поддержка проекта, помощь в подборе аналогов, поставка прототипов;
- Система менеджмента качества сертифицирована по Международному стандарту ISO 9001;
- Лицензия ФСБ на осуществление работ с использованием сведений, составляющих государственную тайну;
- Поставка специализированных компонентов (Xilinx, Altera, Analog Devices, Intersil, Interpoint, Microsemi, Aeroflex, Peregrine, Syfer, Eurofarad, Texas Instrument, Miteq, Cobham, E2V, MA-COM, Hittite, Mini-Circuits, General Dynamics и др.);

Помимо этого, одним из направлений компании «ЭлектроПласт» является направление «Источники питания». Мы предлагаем Вам помощь Конструкторского отдела:

- Подбор оптимального решения, техническое обоснование при выборе компонента;
- Подбор аналогов;
- Консультации по применению компонента;
- Поставка образцов и прототипов;
- Техническая поддержка проекта;
- Защита от снятия компонента с производства.



Как с нами связаться

Телефон: 8 (812) 309 58 32 (многоканальный)

Факс: 8 (812) 320-02-42

Электронная почта: org@eplast1.ru

Адрес: 198099, г. Санкт-Петербург, ул. Калинина, дом 2, корпус 4, литера А.