

Features

- Very Broadband Performance
- Low Insertion Loss: 1.75 dB Typical @ 18 GHz
- High Isolation: 50 dB Typical @ 18 GHz
- Fast Switching Speed: 2 ns Typical
- Reflective Configuration
- Ultra Low DC Power Consumption
- Via Hole Grounding

Description

M/A-COM's MASW20000 is a versatile, high isolation SPDT switch. Designed on M/A-COM's mature 1-micron MESFET process, this parts is ideal for modules or other packaging for use in the Cellular, GPS, LAN and infrastructure markets.

Demonstrating performance up to 20 GHz, the MASW20000 will perform well in many types of applications within that range.

Ordering Information¹

Part Number	Package
MASW20000	Die

1. Die quantity varies.

Absolute Maximum Ratings²

Parameter	Absolute Maximum
Control Voltage (A1/B2 or A2/B1)	-8.5 VDC
Input RF Power	+34 dBm
Operating Temperature	+175°C
Storage Temperature	-65°C to +175°C

2. Exceeding any one or combination of these limits may cause permanent damage to this device.

Pad Layout

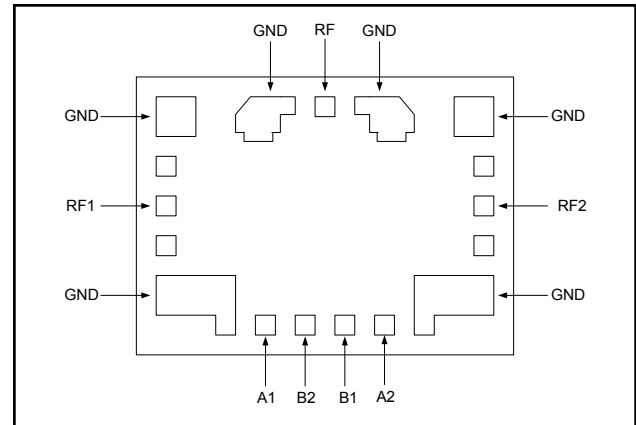

Bond Pad Dimensions

Bond Pad	Dimension Inches (mm)
RF, RF1, RF2	0.004 x 0.004 (0.100 x 0.100)
A1, A2, B1, B2	0.004 x 0.004 (0.100 x 0.100)
DIE Size	0.083 x 0.035 x 0.004 (2.10 x 0.89 x 0.10)

Schematic

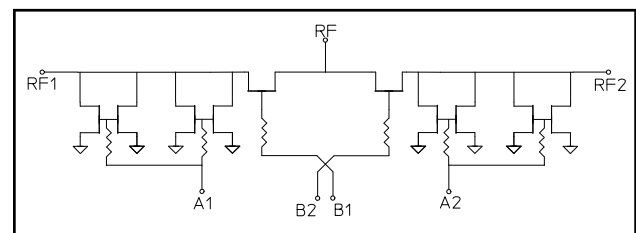

Electrical Specifications³: $T_A = 25^\circ\text{C}$, $Z_0 = 50\Omega$, $+25^\circ\text{C}$ ⁴

Parameter	Test Conditions	Units	Min.	Typ.	Max.
Insertion Loss	10 GHz	dB	—	1.4	1.7
	18 GHz	dB	—	1.75	2.1
	20 GHz	dB	—	2.0	2.5
Isolation	10 GHz	dB	50	59	—
	18 GHz	dB	42	49	—
	20 GHz	dB	40	47	—
VSWR	10 GHz	Ratio	—	—	1.6:1
	18 GHz	Ratio	—	—	1.8:1
	20 GHz	Ratio	—	—	2.0:1
Trise, Tfall	10% to 90% RF and 90% to 10% RF	ns	—	2	—
Ton, Toff	50% control to 90% RF, and 50% control to 10% RF	ns	—	3	—
Transients	In-Band	mV	—	20	—
Input P1dB	0.5 - 20 GHz, 0 to -5 V	dBm	—	25	—
	0.05 GHz, 0 to -5 V	dBm	—	18	—
IP2	Two Tone, +5 dBm/Tone, 5 MHz Spacing, >50 MHz 0.5 - 20 GHz	dBm	—	+59	—
IIP3	Two Tone, +5 dBm/Tone, 5 MHz Spacing, >50 MHz 0.5 - 20 GHz	dBm	—	+43	—
	0.05 GHz	dBm	—	+27	—
Control Voltage (Complementary Logic)	V_{IN} Low, 0 to -0.2 V	μA	—	—	5
	V_{IN} High, -5 V	μA	—	—	50

3. All specifications apply with 50 Ω impedance connected to all RF ports, 0 and -5 VDC control voltages.

4. Loss changes 0.0025 dB/ $^\circ\text{C}$ (From -55 $^\circ\text{C}$ to +85 $^\circ\text{C}$).

Truth Table^{5,6}

Control Inputs		Condition of Switch	
A1/B2	A2/B1	RF1	RF2
V_{IN} Hi	V_{IN} Low	On	Off
V_{IN} Low	V_{IN} Hi	Off	On

5. V_{IN} Low = 0 to -0.2 V, V_{IN} Hi = -5V

6. For normal SPDT operation A1 is connected to B2 and A2 is connected to B1.

Handling Procedures

Please observe the following precautions to avoid damage:

Static Sensitivity

Gallium Arsenide Integrated Circuits are sensitive to electrostatic discharge (ESD) and can be damaged by static electricity. Proper ESD control techniques should be used when handling these devices.

Typical Performance Curves

Insertion Loss

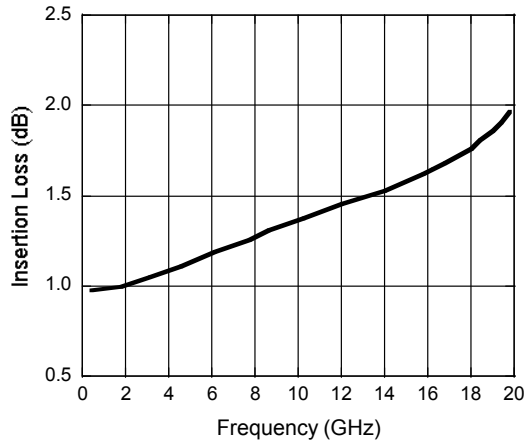

Isolation

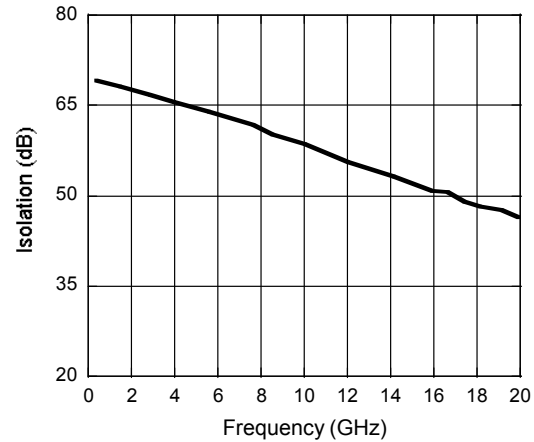

VSWR

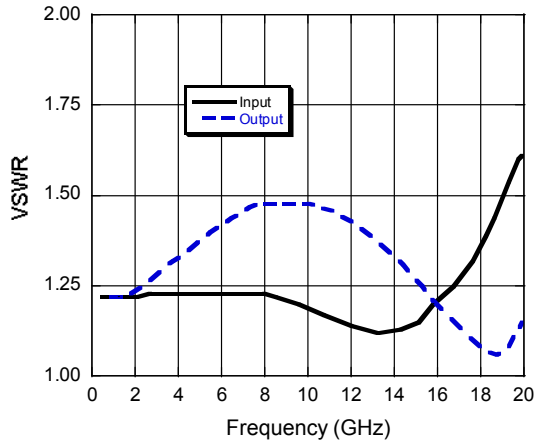

Handling Procedures

Permanent damage to the MASW20000 may occur if the following precautions are not adhered to:

- A. Cleanliness - The MASW20000 should be handled in a clean environment. DO NOT attempt to clean assembly after the MASW20000 is installed.
- B. Static Sensitivity - All die handling equipment and personnel should be DC grounded.
- C. Transients - Avoid instrument and power supply transients while bias is connected to the MASW20000. Use shielded signal and bias cables to minimize inductive pick-up.
- D. Bias - Apply voltage to either control port A1/B2 or A2/B1 only when the other is grounded. Neither port should be allowed to "float".
- E. General Handling - It is recommended that the MASW20000 chip be handled along the long side of the die with a sharp pair of bent tweezers. DO NOT touch the surface of the chip with fingers or tweezers.

Mounting

The MASW20000 is back-metallized with Pd/Ni/Au (100/1,000/30,000Å) metallization. It can be die-mounted using Au/Sn eutectic preforms or a thermally conductive epoxy. The package surface should be clean and flat before attachment.

Eutectic Die Attach:

- A. An 80/20 Au/Sn preform is recommended with a work surface temperature of approximately 255°C and a tool temperature of 265°C. When hot 90/10 nitrogen/hydrogen gas is applied, solder temperature should be approximately 290°C.
- B. DO NOT expose the MASW20000 to a temperature greater than 320°C for more than 20 seconds. No more than 3 seconds of scrubbing should be required for attachment.

Epoxy Die Attach:

- A. Apply a minimum amount of epoxy and place the MASW20000 into position. A thin epoxy fillet should be visible around the perimeter of the die.
- B. Cure epoxy per manufacturer's recommended schedule.
- C. Electrically conductive epoxy is recommended but is not required.

Wire Bonding

- A. Ball or wedge bond with 1.0 mil diameter pure gold wire. Gold ribbon (3.0 mil x 0.5 mil) may also be used. Thermo sonic wire bonding with a nominal stage temperature of 150°C and a ball bonding force of 40 to 50 grams or wedge bonding force of 18 to 22 grams is recommended. Ultrasonic energy and time should be adjusted to the minimum levels to achieve reliable wirebonds.
- B. Wirebonds should be started on the chip and terminated on the package.



Компания «ЭлектроПласт» предлагает заключение долгосрочных отношений при поставках импортных электронных компонентов на взаимовыгодных условиях!

Наши преимущества:

- Оперативные поставки широкого спектра электронных компонентов отечественного и импортного производства напрямую от производителей и с крупнейших мировых складов;
- Поставка более 17-ти миллионов наименований электронных компонентов;
- Поставка сложных, дефицитных, либо снятых с производства позиций;
- Оперативные сроки поставки под заказ (от 5 рабочих дней);
- Экспресс доставка в любую точку России;
- Техническая поддержка проекта, помощь в подборе аналогов, поставка прототипов;
- Система менеджмента качества сертифицирована по Международному стандарту ISO 9001;
- Лицензия ФСБ на осуществление работ с использованием сведений, составляющих государственную тайну;
- Поставка специализированных компонентов (Xilinx, Altera, Analog Devices, Intersil, Interpoint, Microsemi, Aeroflex, Peregrine, Syfer, Eurofarad, Texas Instrument, Miteq, Cobham, E2V, MA-COM, Hittite, Mini-Circuits, General Dynamics и др.);

Помимо этого, одним из направлений компании «ЭлектроПласт» является направление «Источники питания». Мы предлагаем Вам помощь Конструкторского отдела:

- Подбор оптимального решения, техническое обоснование при выборе компонента;
- Подбор аналогов;
- Консультации по применению компонента;
- Поставка образцов и прототипов;
- Техническая поддержка проекта;
- Защита от снятия компонента с производства.



Как с нами связаться

Телефон: 8 (812) 309 58 32 (многоканальный)

Факс: 8 (812) 320-02-42

Электронная почта: org@eplast1.ru

Адрес: 198099, г. Санкт-Петербург, ул. Калинина, дом 2, корпус 4, литера А.