

Manganese Dioxide Lithium Coin Batteries: Individual Specifications

CR1025

■ Dimensions(mm)

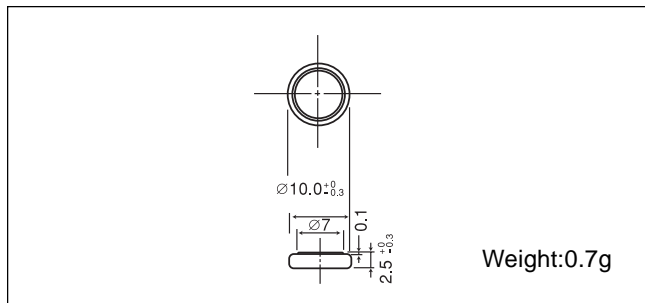

■ Specification

Nominal voltage (V)	3
Nominal capacity (mAh)	30
Continuous standard load (mA)	0.1
Operating temperature (C)	-30 ~ +60

■ Temperature Characteristics

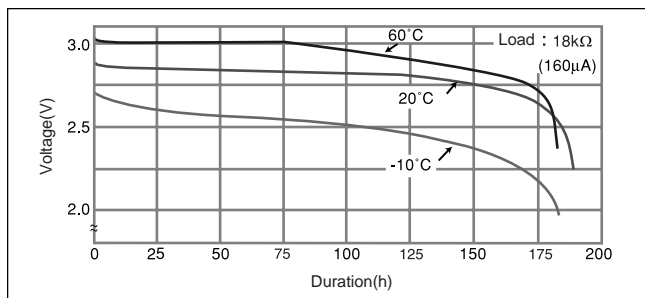

■ Operating voltage vs. load resistance (voltage at 50% discharge depth)

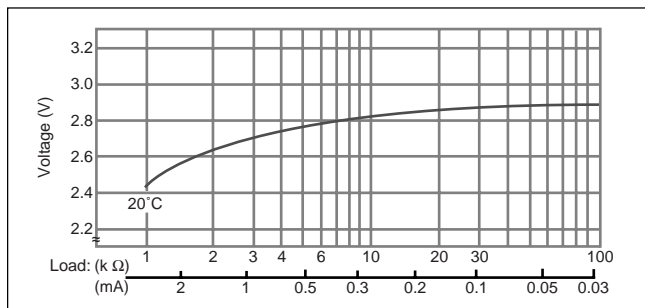

■ Capacity vs. load resistance

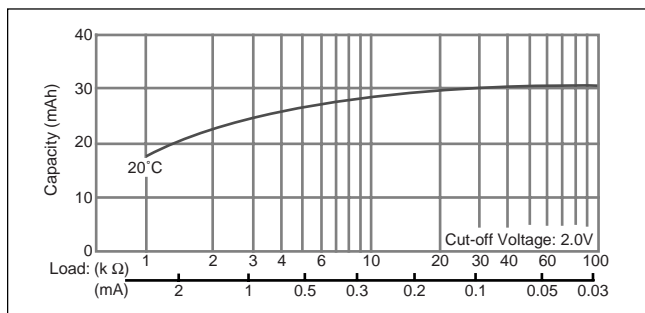

CR1216

■ Dimensions(mm)

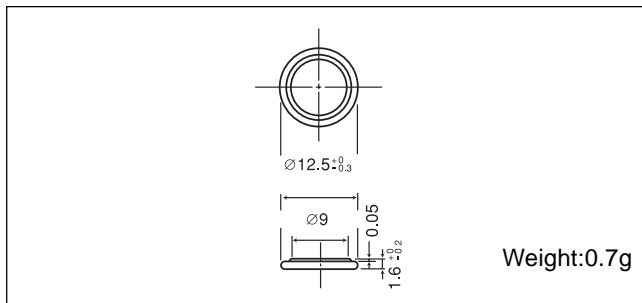

■ Specification

Nominal voltage (V)	3
Nominal capacity (mAh)	25
Continuous standard load (mA)	0.1
Operating temperature (C)	-30 ~ +60

■ Temperature Characteristics

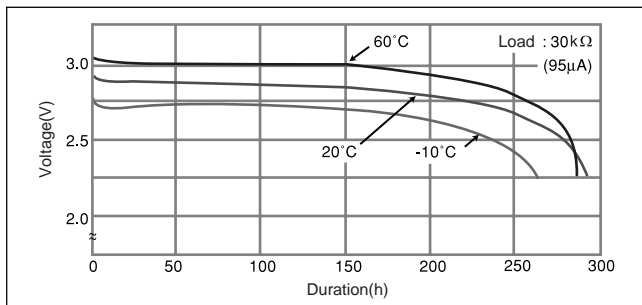

■ Operating voltage vs. load resistance (voltage at 50% discharge depth)

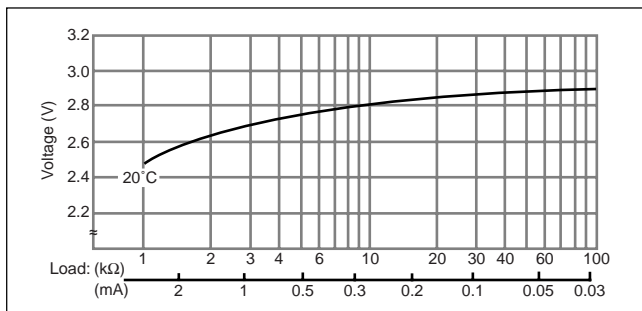

■ Capacity vs. load resistance

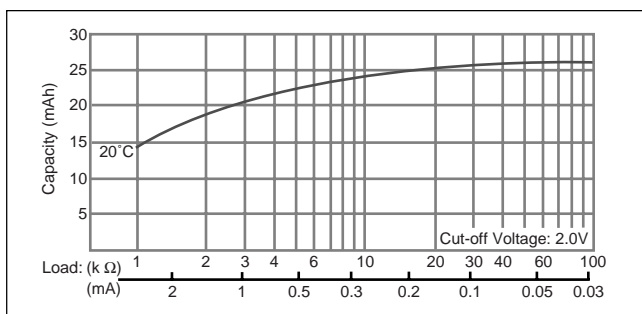

Manganese Dioxide Lithium Coin Batteries: Individual Specifications

CR1025

■ Dimensions(mm)

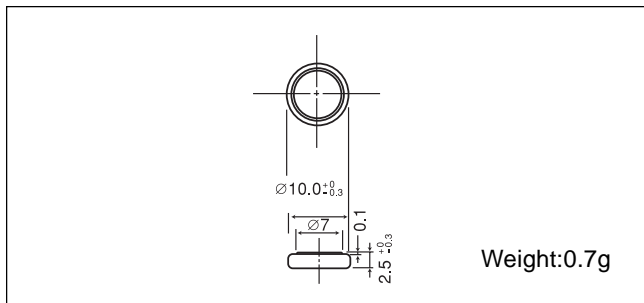

■ Specification

Nominal voltage (V)	3
Nominal capacity (mAh)	30
Continuous standard load (mA)	0.1
Operating temperature (C)	-30 ~ +60

■ Temperature Characteristics

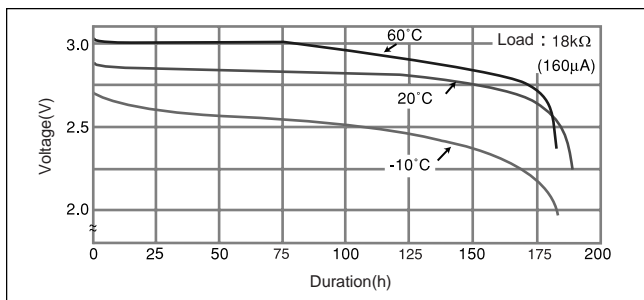

■ Operating voltage vs. load resistance (voltage at 50% discharge depth)

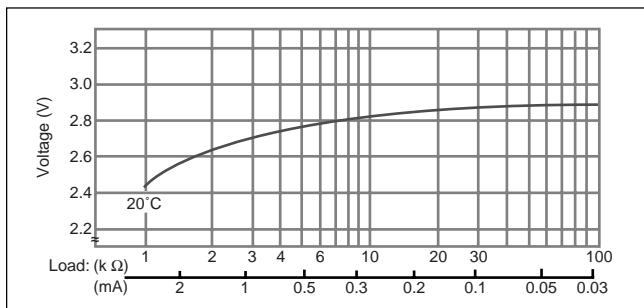

■ Capacity vs. load resistance

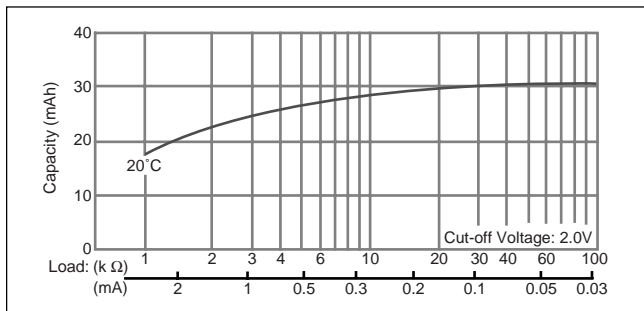

CR1216

■ Dimensions(mm)

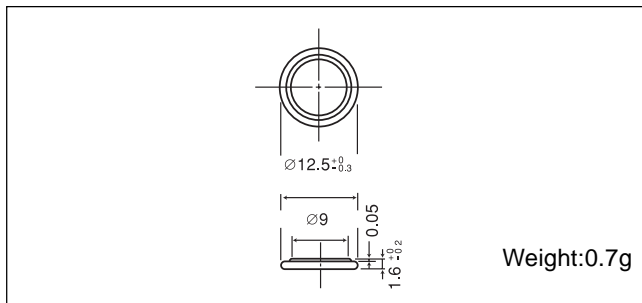

■ Specification

Nominal voltage (V)	3
Nominal capacity (mAh)	25
Continuous standard load (mA)	0.1
Operating temperature (C)	-30 ~ +60

■ Temperature Characteristics

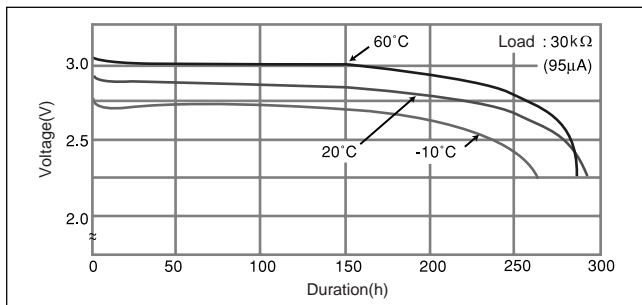

■ Operating voltage vs. load resistance (voltage at 50% discharge depth)

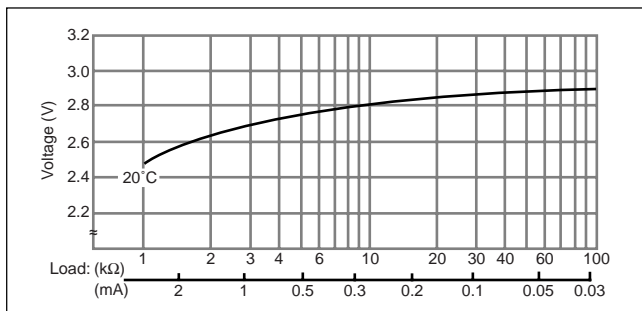

■ Capacity vs. load resistance

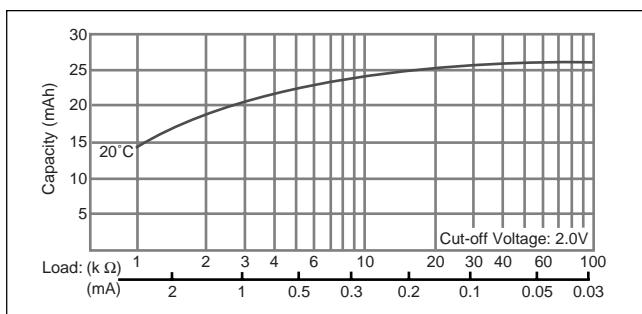

Manganese Dioxide Lithium Coin Batteries: Individual Specifications

CR1220

■ Dimensions(mm)

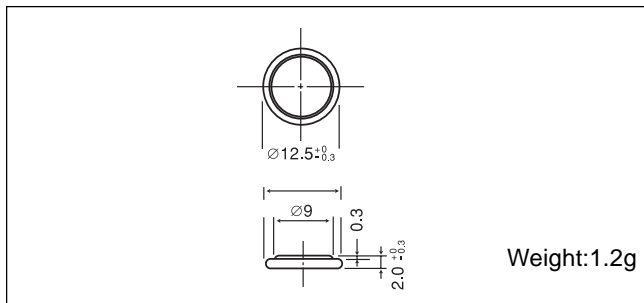

■ Specification

Nominal voltage (V)	3
Nominal capacity (mAh)	35
Continuous standard load (mA)	0.1
Operating temperature (C)	-30 ~ +60

■ Temperature Characteristics

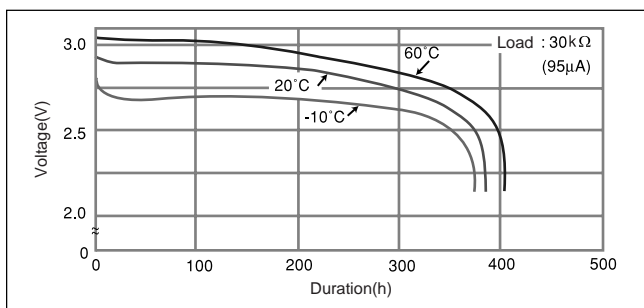

■ Operating voltage vs. load resistance (voltage at 50% discharge depth)

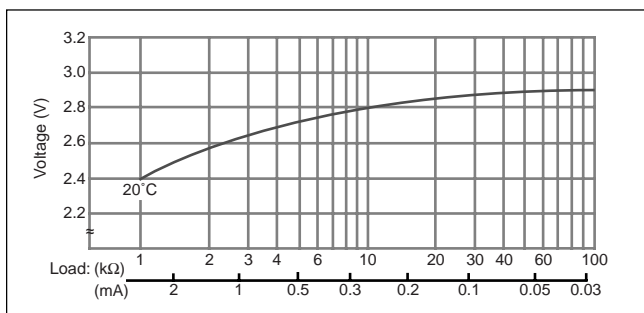

■ Capacity vs. load resistance

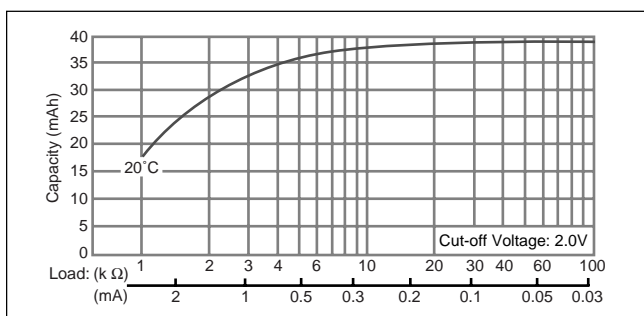

CR1612

■ Dimensions(mm)

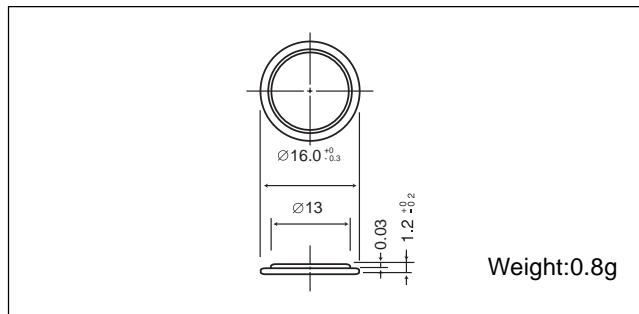

■ Specification

Nominal voltage (V)	3
Nominal capacity (mAh)	40
Continuous standard load (mA)	0.1
Operating temperature (C)	-30 ~ +60

■ Temperature Characteristics

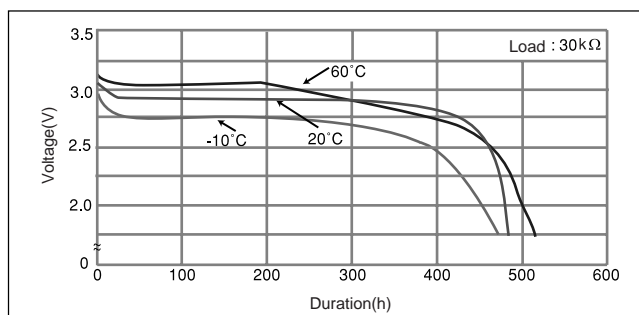

■ Operating voltage vs. load resistance (voltage at 50% discharge depth)

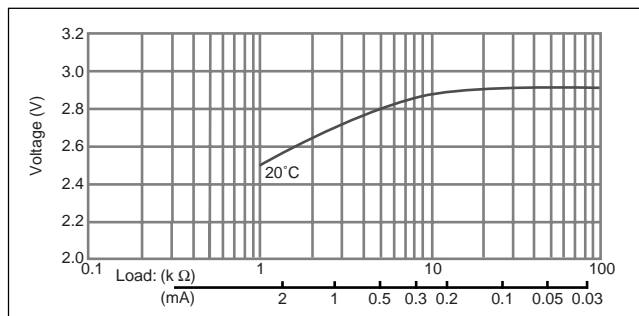

■ Capacity vs. load resistance

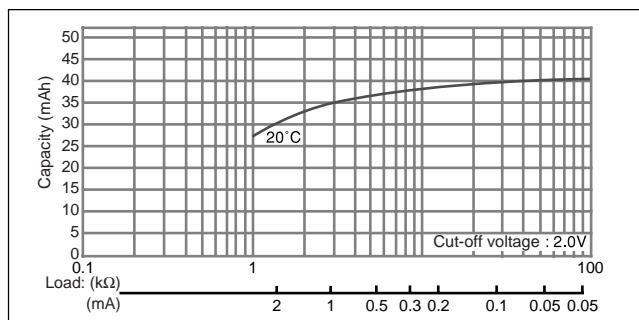

Manganese Dioxide Lithium Coin Batteries: Individual Specifications

CR1220

■ Dimensions(mm)

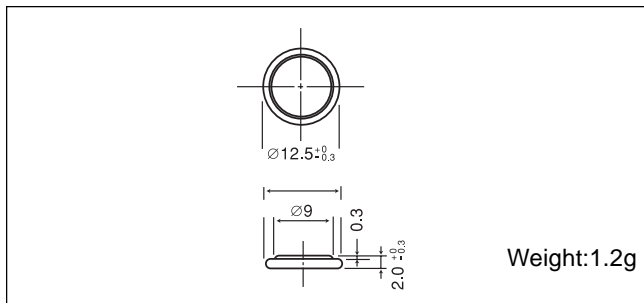

■ Specification

Nominal voltage (V)	3
Nominal capacity (mAh)	35
Continuous standard load (mA)	0.1
Operating temperature (C)	-30 ~ +60

■ Temperature Characteristics

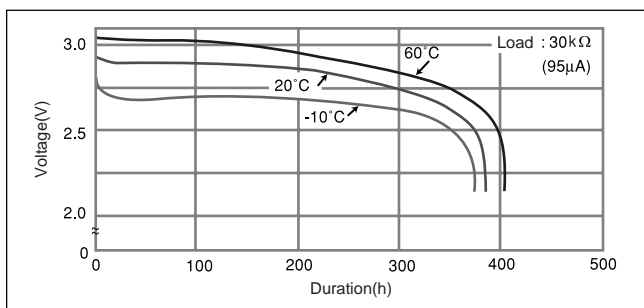

■ Operating voltage vs. load resistance (voltage at 50% discharge depth)

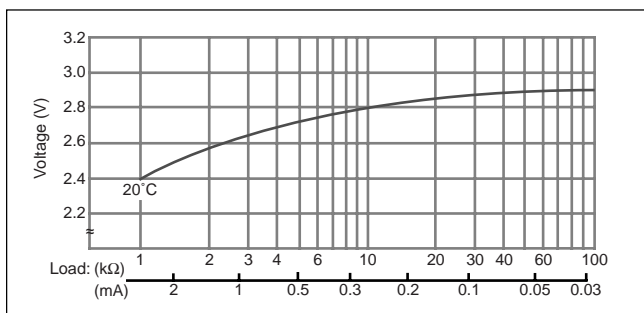

■ Capacity vs. load resistance

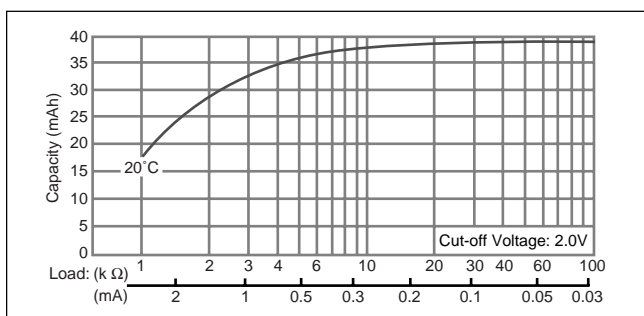

CR1612

■ Dimensions(mm)

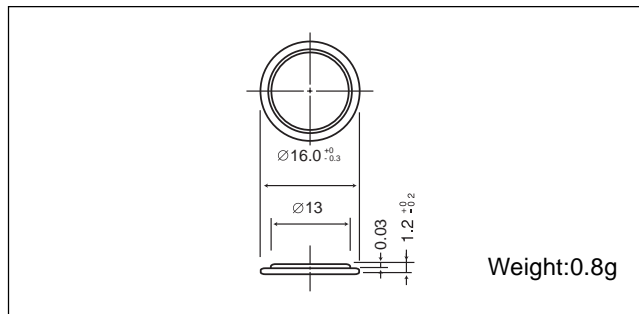

■ Specification

Nominal voltage (V)	3
Nominal capacity (mAh)	40
Continuous standard load (mA)	0.1
Operating temperature (C)	-30 ~ +60

■ Temperature Characteristics

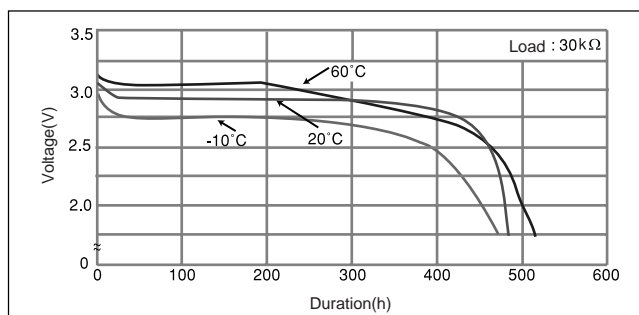

■ Operating voltage vs. load resistance (voltage at 50% discharge depth)

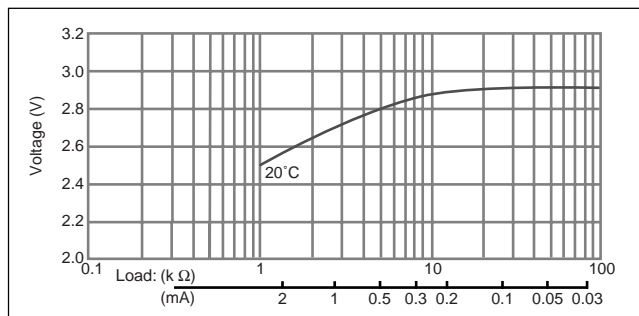

■ Capacity vs. load resistance

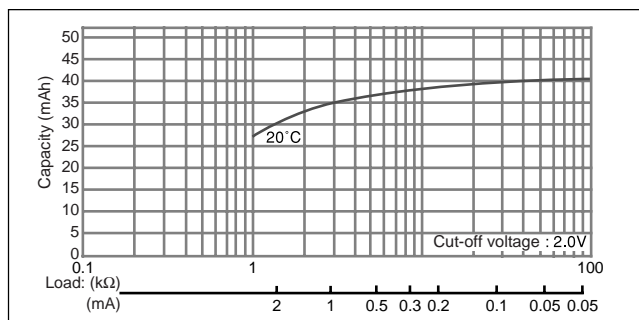

Manganese Dioxide Lithium Coin Batteries: Individual Specifications

CR1616

■ Dimensions(mm)

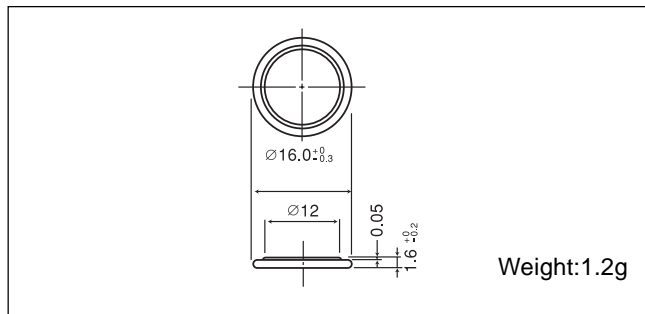

■ Specification

Nominal voltage (V)	3
Nominal capacity (mAh)	55
Continuous standard load (mA)	0.1
Operating temperature (C)	-30 ~ +60

■ Temperature Characteristics

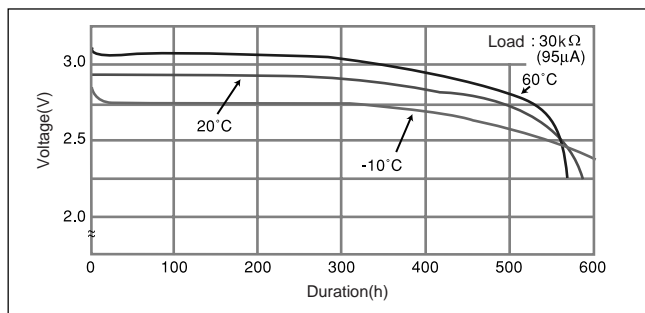

■ Operating voltage vs. load resistance (voltage at 50% discharge depth)

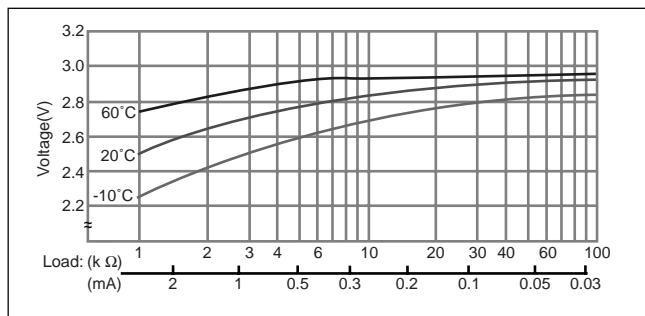

■ Capacity vs. load resistance

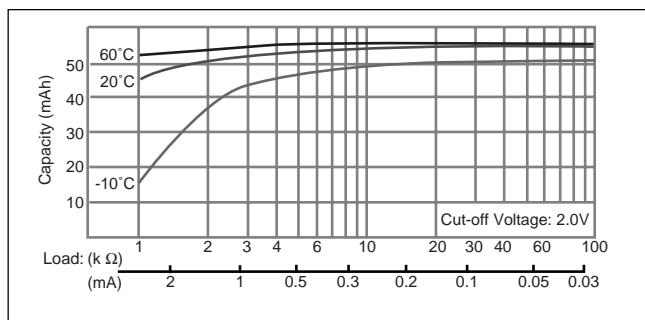

CR1620

■ Dimensions(mm)

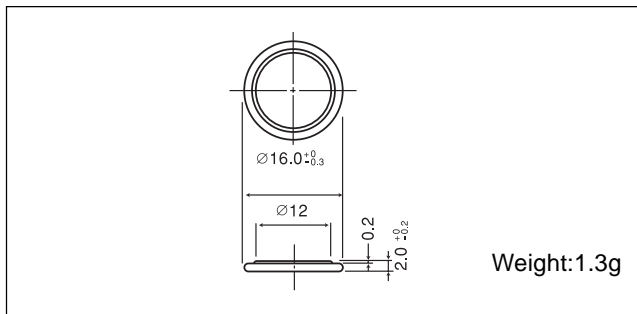

■ Specification

Nominal voltage (V)	3
Nominal capacity (mAh)	75
Continuous standard load (mA)	0.1
Operating temperature (C)	-30 ~ +60

■ Temperature Characteristics

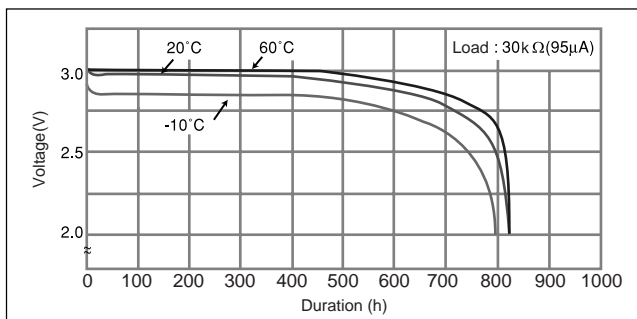

■ Operating voltage vs. load resistance (voltage at 50% discharge depth)

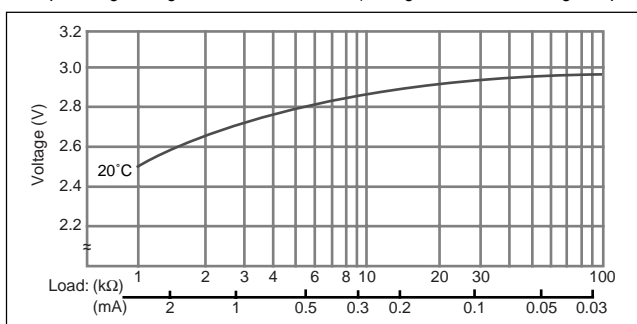

■ Capacity vs. load resistance

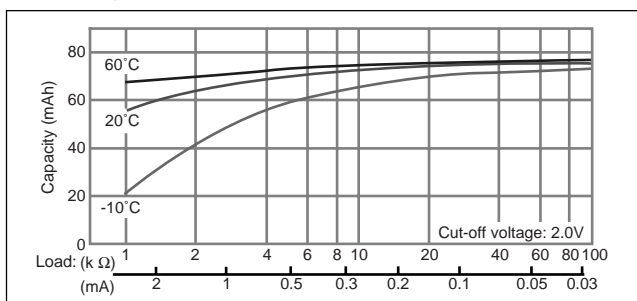

Manganese Dioxide Lithium Coin Batteries: Individual Specifications

CR1616

■ Dimensions(mm)

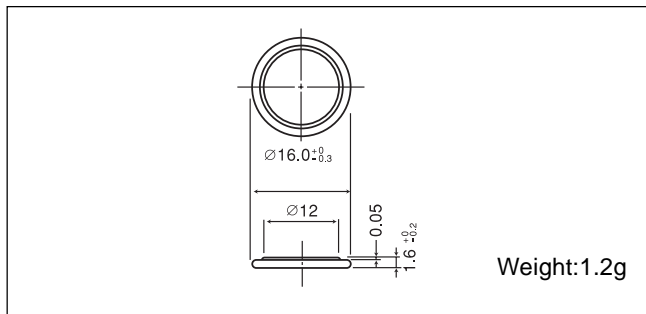

■ Specification

Nominal voltage (V)	3
Nominal capacity (mAh)	55
Continuous standard load (mA)	0.1
Operating temperature (C)	-30 ~ +60

■ Temperature Characteristics

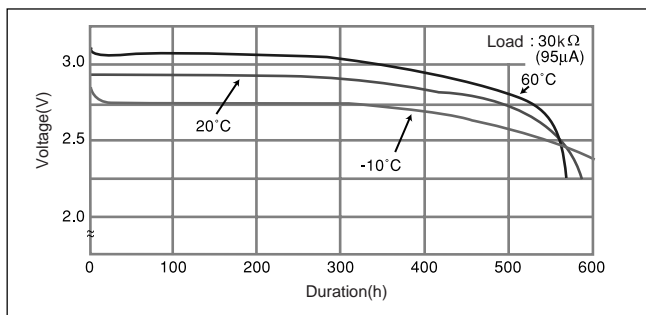

■ Operating voltage vs. load resistance (voltage at 50% discharge depth)

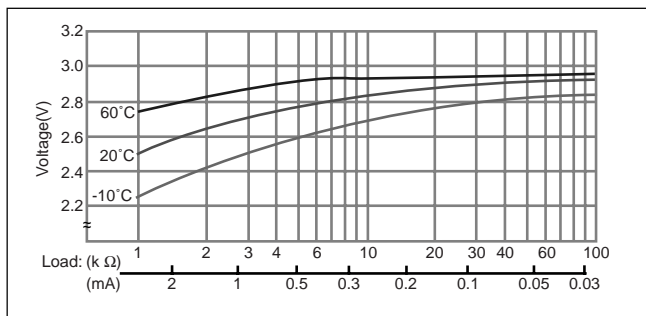

■ Capacity vs. load resistance

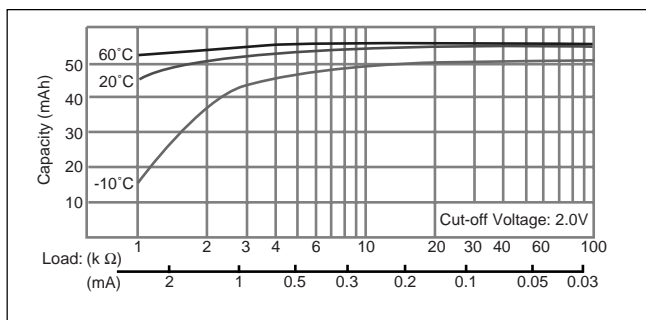

CR1620

■ Dimensions(mm)

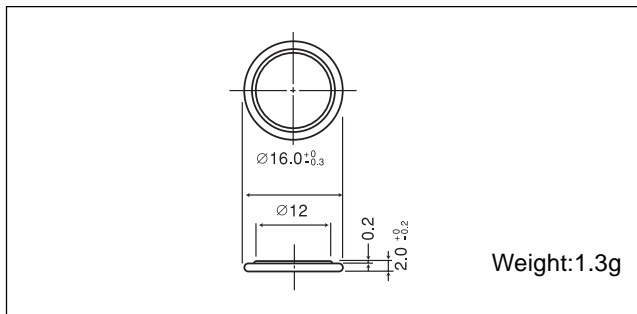

■ Specification

Nominal voltage (V)	3
Nominal capacity (mAh)	75
Continuous standard load (mA)	0.1
Operating temperature (C)	-30 ~ +60

■ Temperature Characteristics

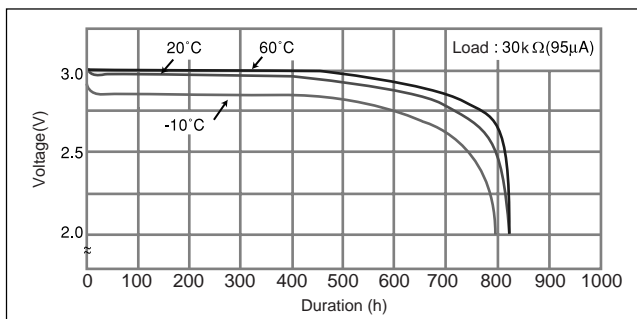

■ Operating voltage vs. load resistance (voltage at 50% discharge depth)

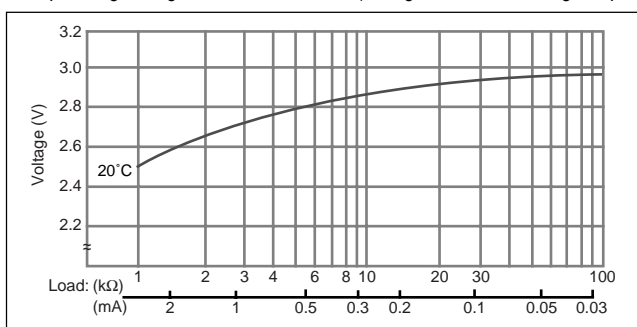

■ Capacity vs. load resistance

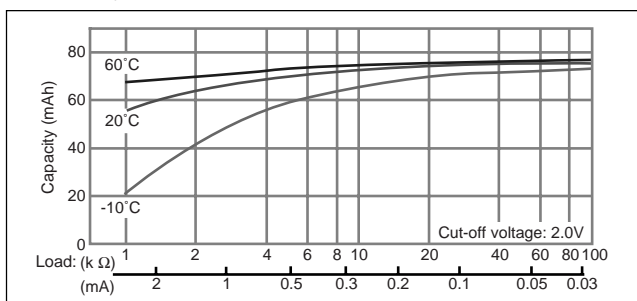

Manganese Dioxide Lithium Coin Batteries: Individual Specifications

CR1632

■ Dimensions(mm)

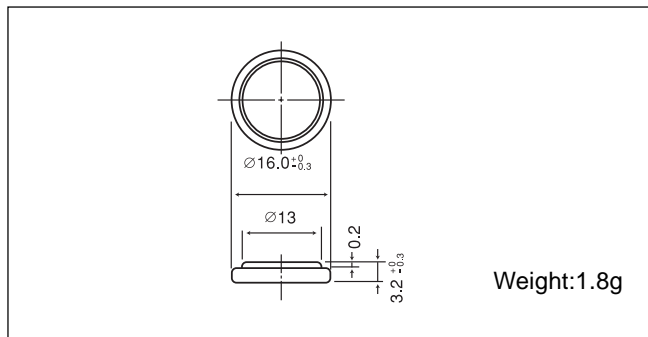

■ Specification

Nominal voltage (V)	3
Nominal capacity (mAh)	140
Continuous standard load (mA)	0.1
Operating temperature (C)	-30 ~ +60

■ Temperature Characteristics

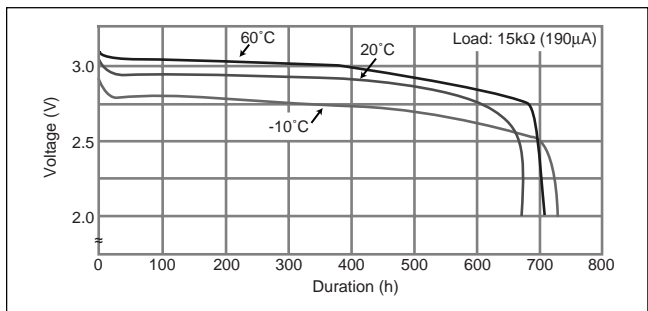

■ Operating voltage vs. load resistance (voltage at 50% discharge depth)

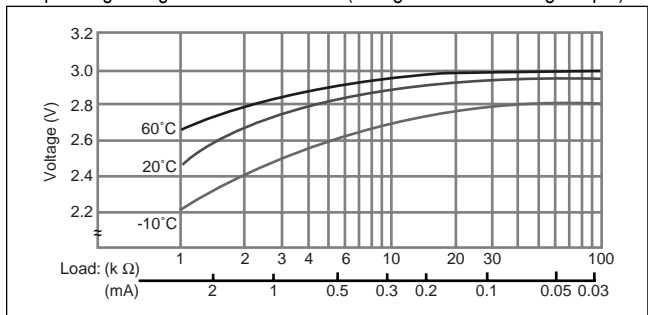

■ Capacity vs. load resistance

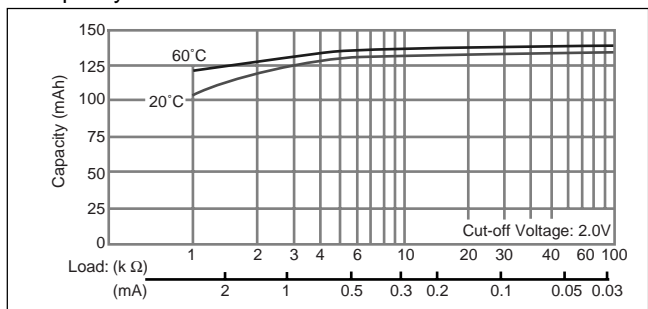

CR2012

■ Dimensions(mm)

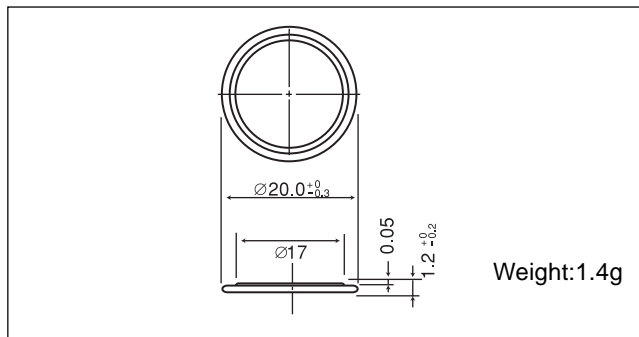

■ Specification

Nominal voltage (V)	3
Nominal capacity (mAh)	55
Continuous standard load (mA)	0.1
Operating temperature (C)	-30 ~ +60

■ Temperature Characteristics

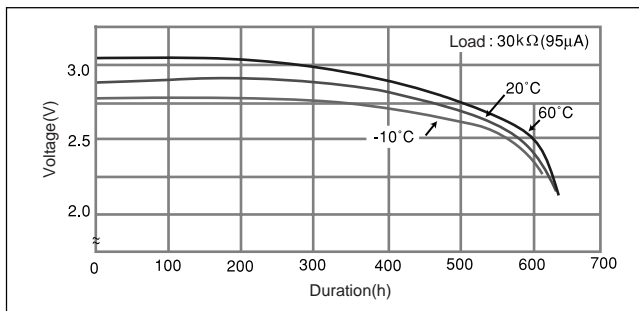

■ Operating voltage vs. load resistance (voltage at 50% discharge depth)

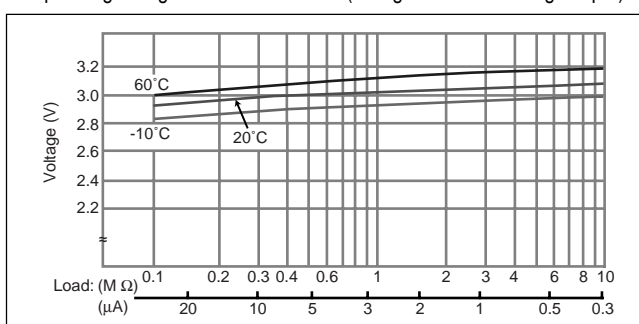

■ Capacity vs. load resistance

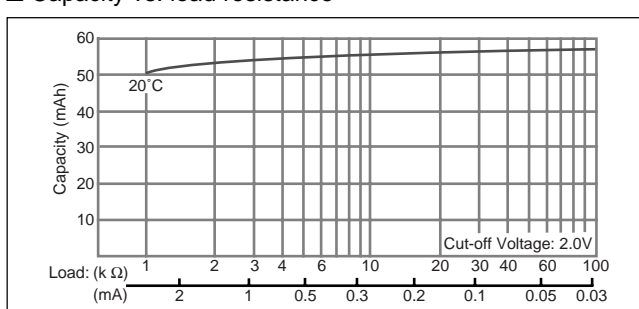

Manganese Dioxide Lithium Coin Batteries: Individual Specifications

CR2016

■ Dimensions(mm)

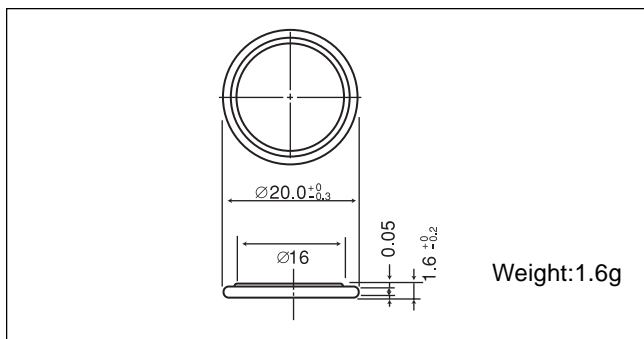

■ Specification

Nominal voltage (V)	3
Nominal capacity (mAh)	90
Continuous standard load (mA)	0.1
Operating temperature (C)	-30 ~ +60

■ Temperature Characteristics

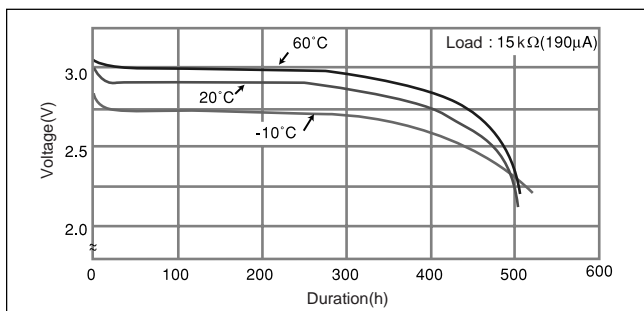

■ Operating voltage vs. load resistance (voltage at 50% discharge depth)

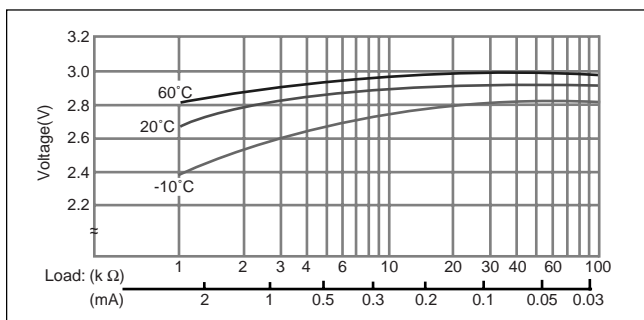

■ Capacity vs. load resistance

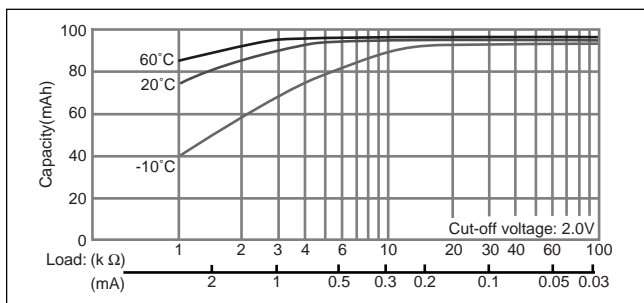

CR2025

■ Dimensions(mm)

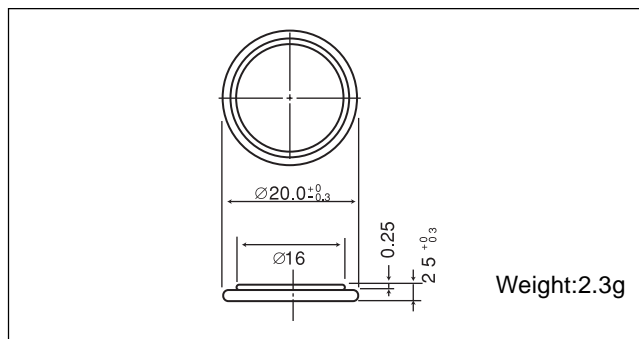

■ Specification

Nominal voltage (V)	3
Nominal capacity (mAh)	165
Continuous standard load (mA)	0.2
Operating temperature (C)	-30 ~ +60

■ Temperature Characteristics

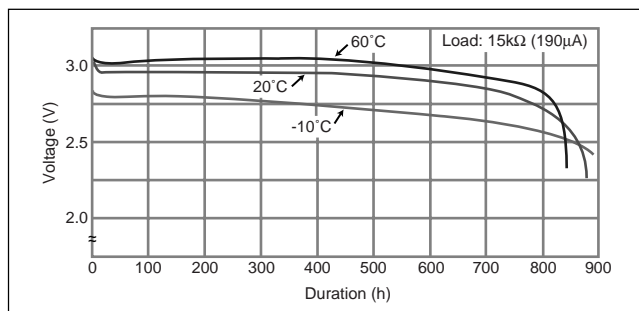

■ Operating voltage vs. load resistance (voltage at 50% discharge depth)

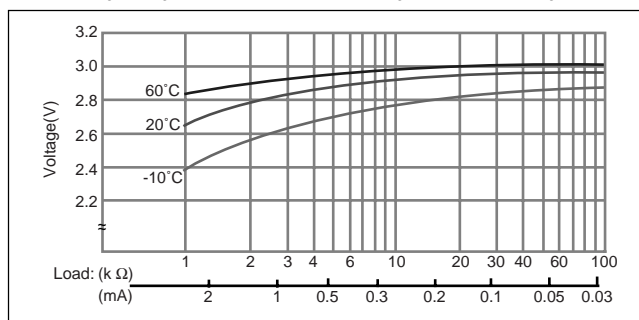

■ Capacity vs. load resistance

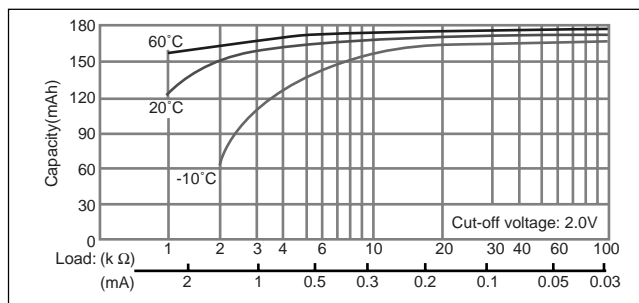

Manganese Dioxide Lithium Coin Batteries: Individual Specifications

CR2016

■ Dimensions(mm)

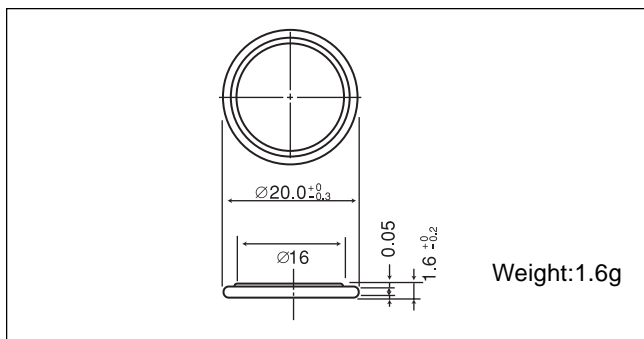

■ Specification

Nominal voltage (V)	3
Nominal capacity (mAh)	90
Continuous standard load (mA)	0.1
Operating temperature (C)	-30 ~ +60

■ Temperature Characteristics

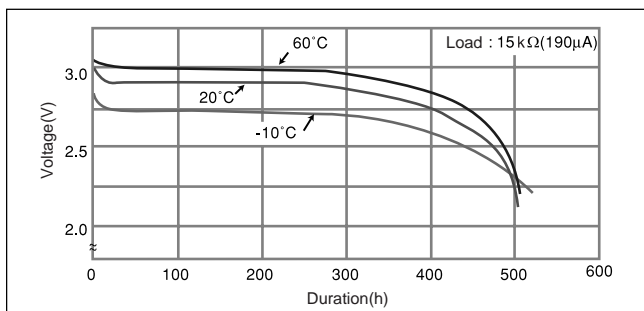

■ Operating voltage vs. load resistance (voltage at 50% discharge depth)

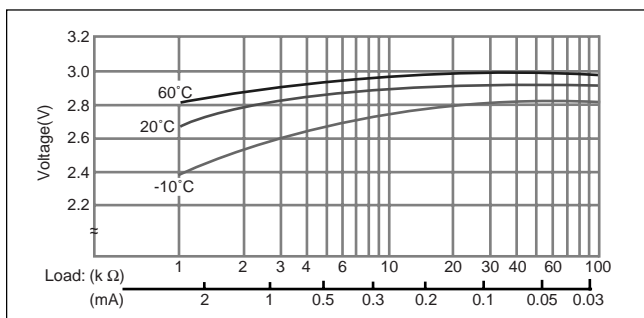

■ Capacity vs. load resistance

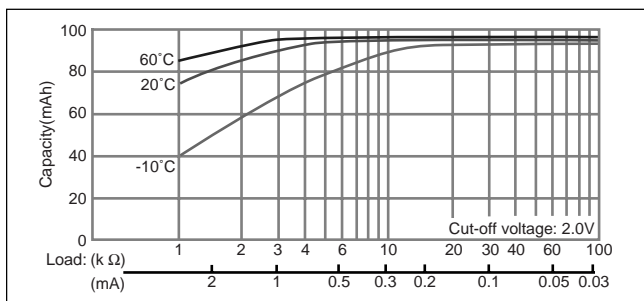

CR2025

■ Dimensions(mm)

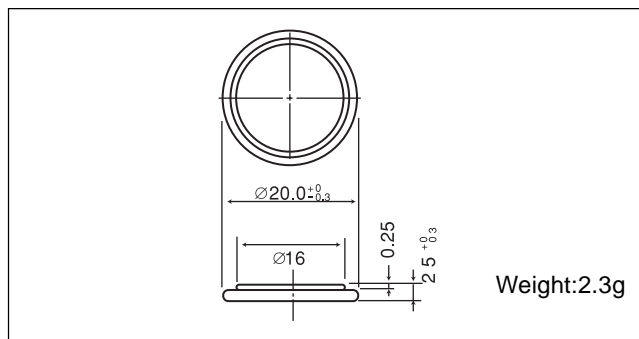

■ Specification

Nominal voltage (V)	3
Nominal capacity (mAh)	165
Continuous standard load (mA)	0.2
Operating temperature (C)	-30 ~ +60

■ Temperature Characteristics

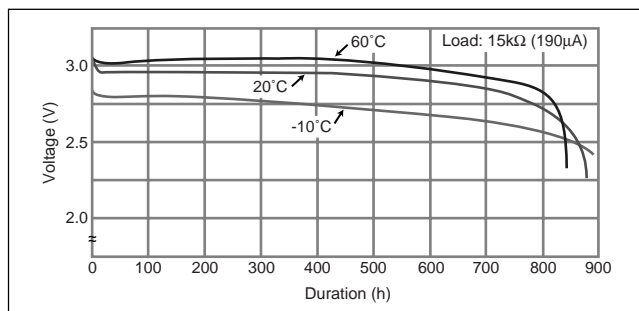

■ Operating voltage vs. load resistance (voltage at 50% discharge depth)

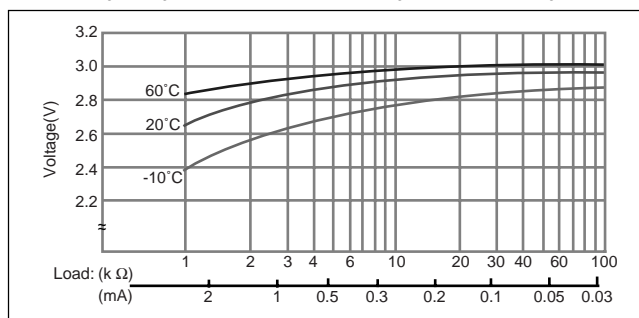

■ Capacity vs. load resistance

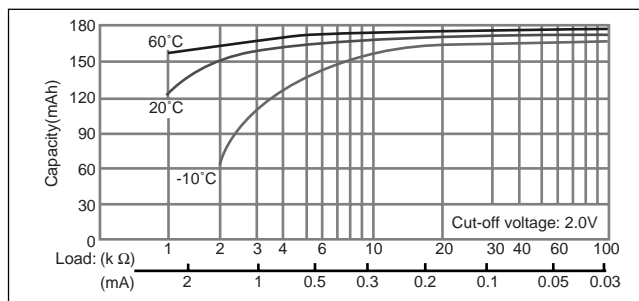

Manganese Dioxide Lithium Coin Batteries: Individual Specifications

CR2032

□ Dimensions(mm)

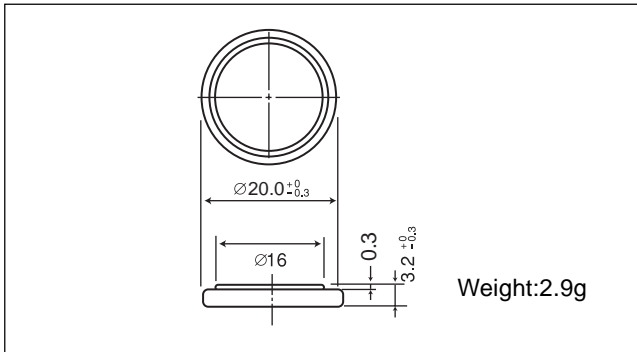

□ Specification

Nominal voltage (V)	3
Nominal capacity (mAh)	225
Continuous standard load (mA)	0.2
Operating temperature (C)	-30 ~ +60

□ Temperature Characteristics

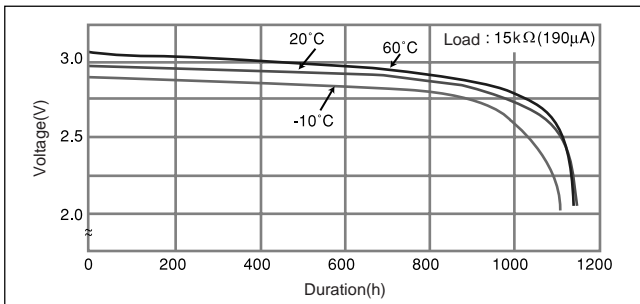

□ Operating voltage vs. load resistance (voltage at 50% discharge depth)

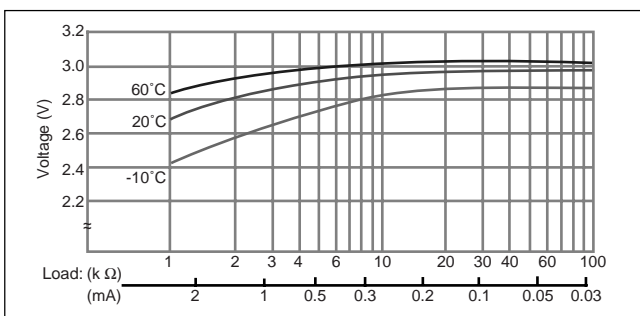

□ Capacity vs. load resistance

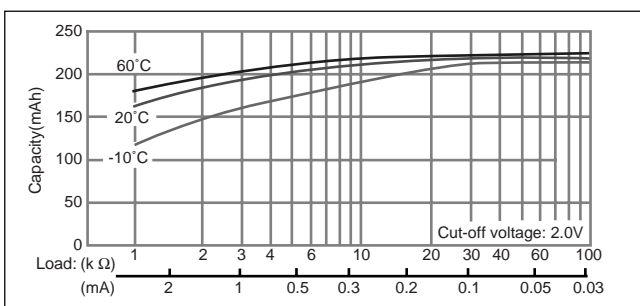

CR2330

□ Dimensions(mm)

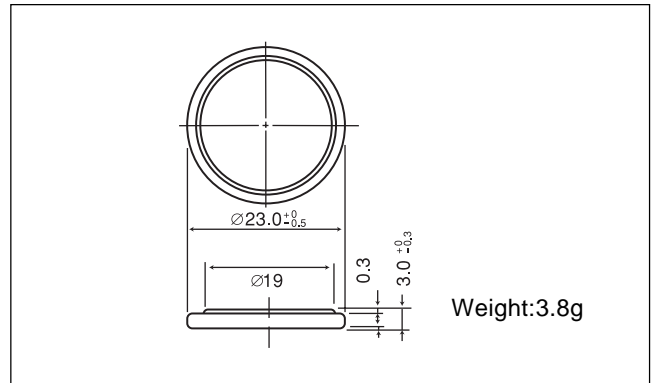

□ Specification

Nominal voltage (V)	3
Nominal capacity (mAh)	265
Continuous standard load (mA)	0.2
Operating temperature (C)	-30 ~ +60

□ Temperature Characteristics

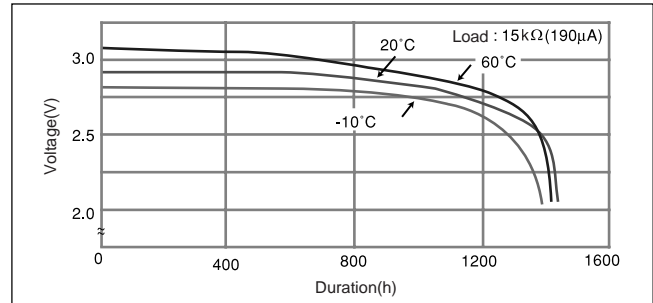

□ Operating voltage vs. load resistance (voltage at 50% discharge depth)

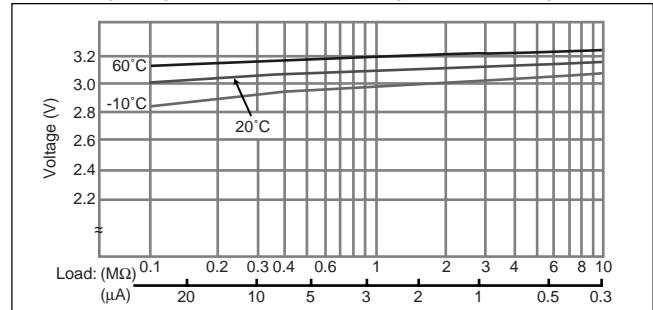

□ Capacity vs. load resistance

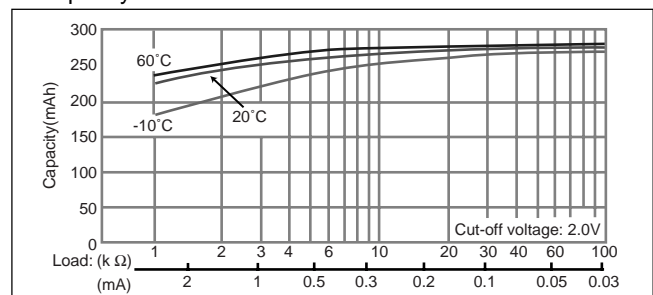

Manganese Dioxide Lithium Coin Batteries: Individual Specifications

CR2032

□ Dimensions(mm)

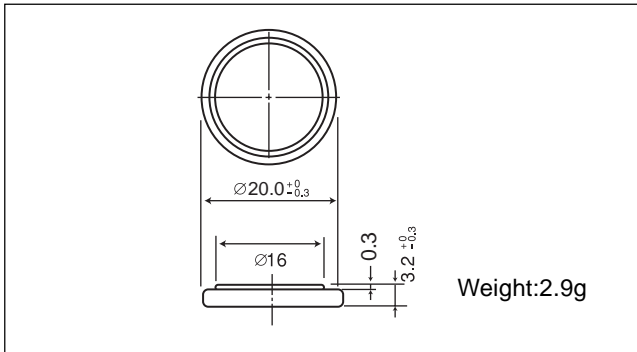

□ Specification

Nominal voltage (V)	3
Nominal capacity (mAh)	225
Continuous standard load (mA)	0.2
Operating temperature (C)	-30 ~ +60

□ Temperature Characteristics

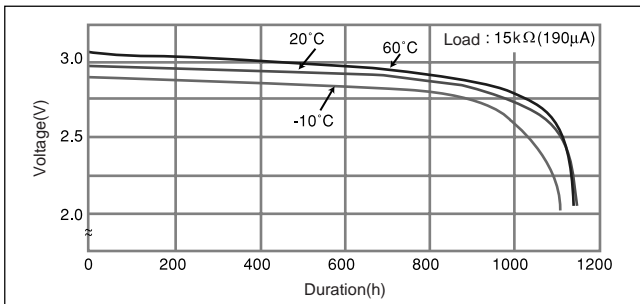

□ Operating voltage vs. load resistance (voltage at 50% discharge depth)

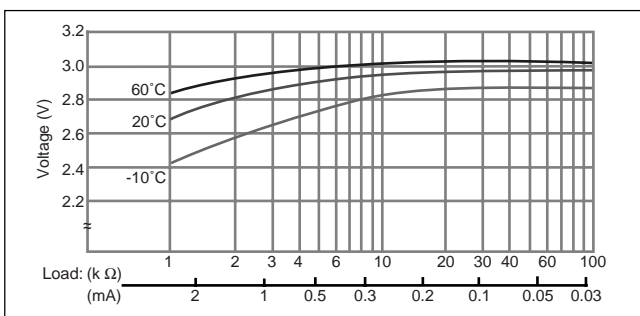

□ Capacity vs. load resistance

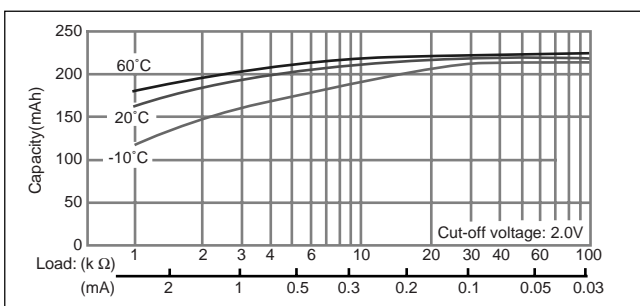

CR2330

□ Dimensions(mm)

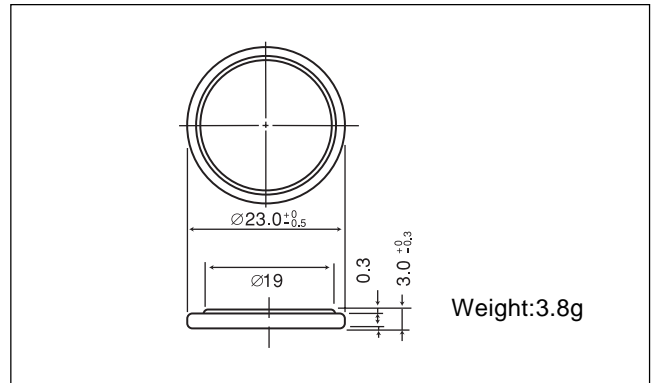

□ Specification

Nominal voltage (V)	3
Nominal capacity (mAh)	265
Continuous standard load (mA)	0.2
Operating temperature (C)	-30 ~ +60

□ Temperature Characteristics

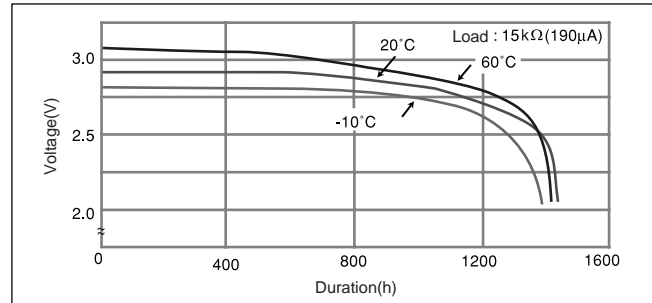

□ Operating voltage vs. load resistance (voltage at 50% discharge depth)

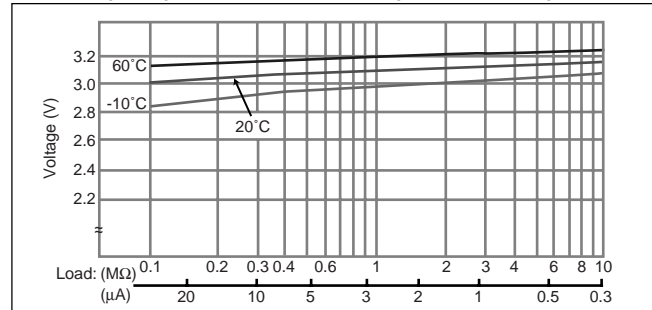

□ Capacity vs. load resistance

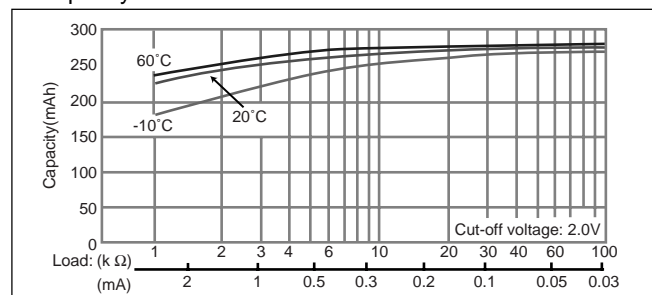

Manganese Dioxide Lithium Coin Batteries: Individual Specifications

CR2354

□ Dimensions(mm)

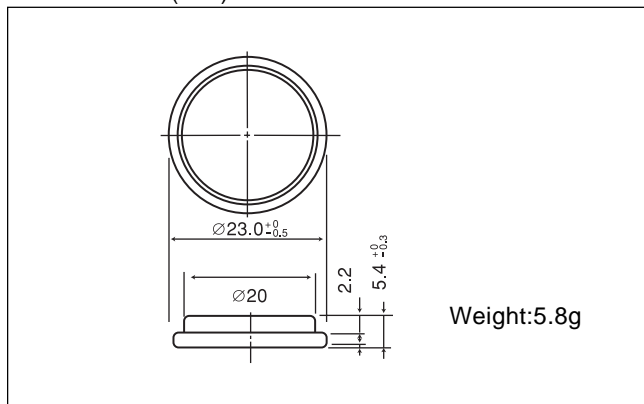

□ Specification

Nominal voltage (V)	3
Nominal capacity (mAh)	560
Continuous standard load (mA)	0.2
Operating temperature (C)	-30 ~ +60

□ Temperature Characteristics

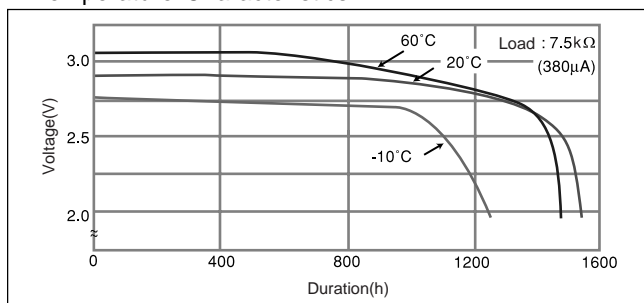

□ Operating voltage vs. load resistance (voltage at 50% discharge depth)

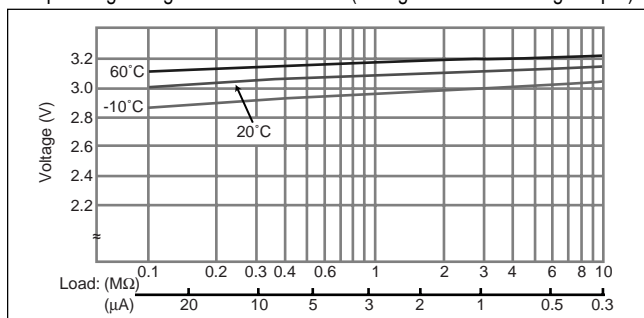

□ Capacity vs. load resistance

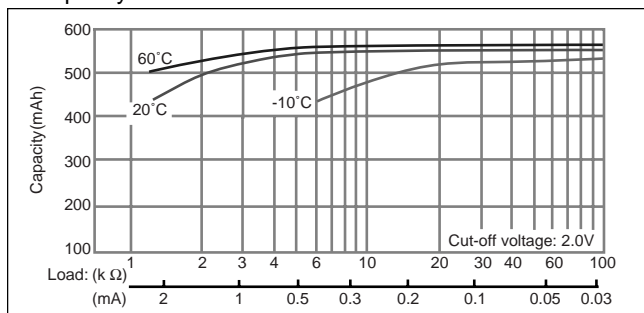

CR2412

□ Dimensions(mm)

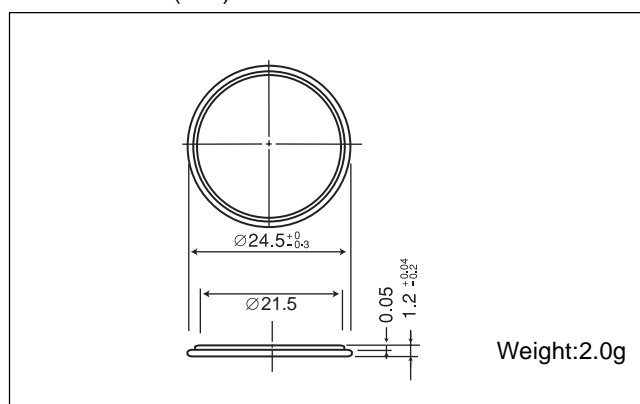

□ Specification

Nominal voltage (V)	3
Nominal capacity (mAh)	100
Continuous standard load (mA)	0.2
Operating temperature (C)	-30 ~ +60

□ Temperature Characteristics

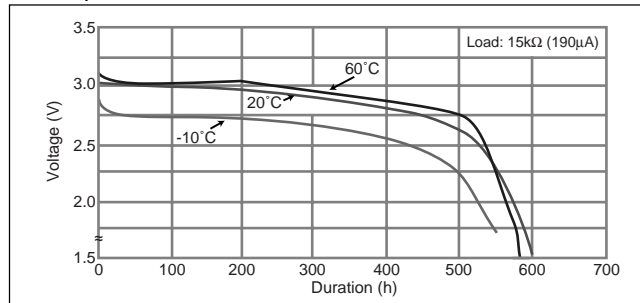

□ Operating voltage vs. load resistance (voltage at 50% discharge depth)

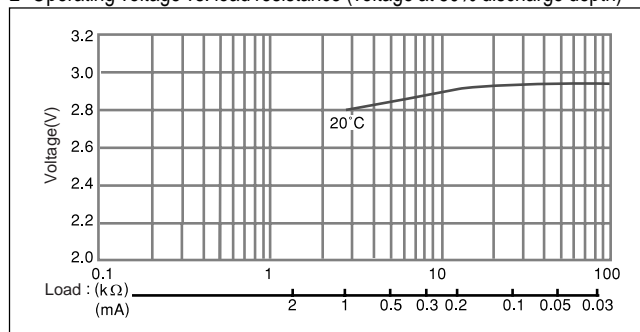

□ Capacity vs. load resistance

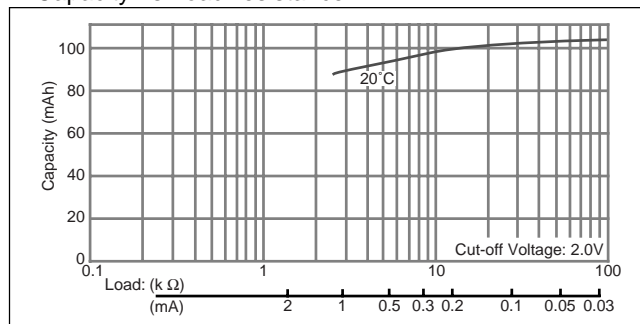

Manganese Dioxide Lithium Coin Batteries: Individual Specifications

CR2354

□ Dimensions(mm)

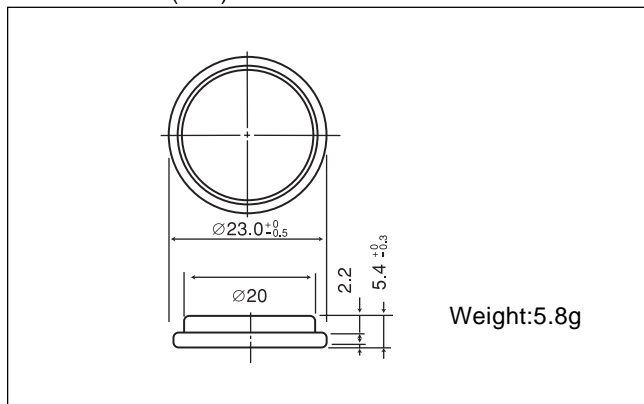

□ Specification

Nominal voltage (V)	3
Nominal capacity (mAh)	560
Continuous standard load (mA)	0.2
Operating temperature (C)	-30 ~ +60

□ Temperature Characteristics

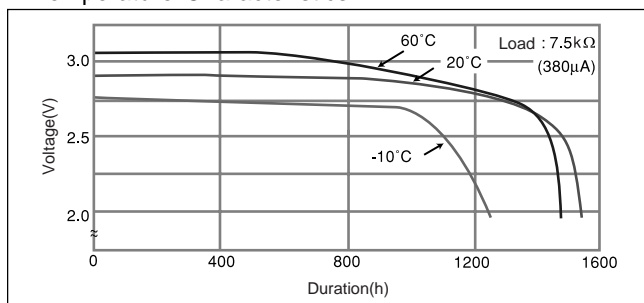

□ Operating voltage vs. load resistance (voltage at 50% discharge depth)

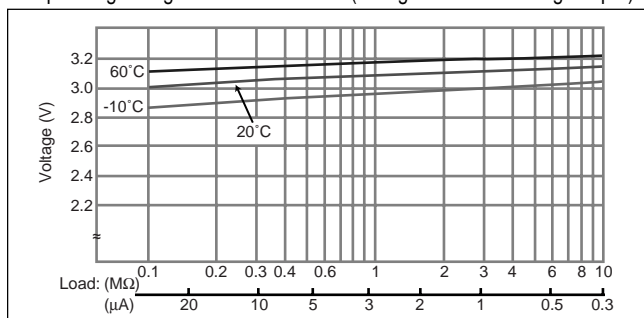

□ Capacity vs. load resistance

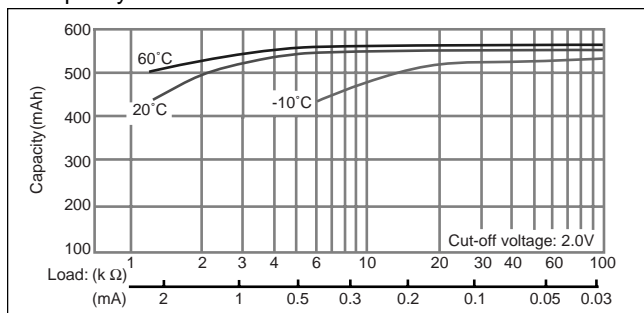

CR2412

□ Dimensions(mm)

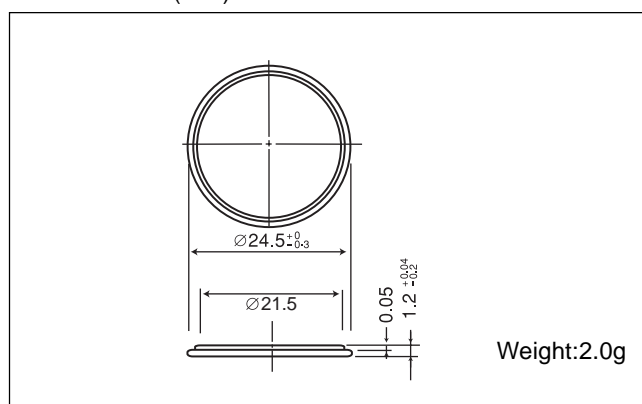

□ Specification

Nominal voltage (V)	3
Nominal capacity (mAh)	100
Continuous standard load (mA)	0.2
Operating temperature (C)	-30 ~ +60

□ Temperature Characteristics

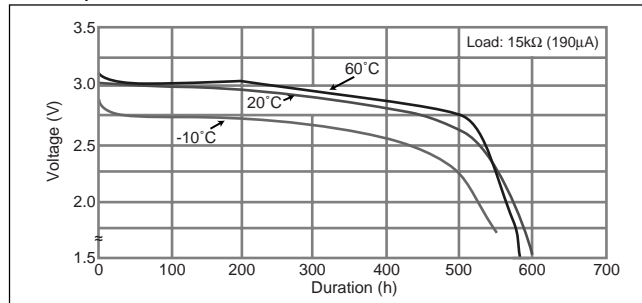

□ Operating voltage vs. load resistance (voltage at 50% discharge depth)

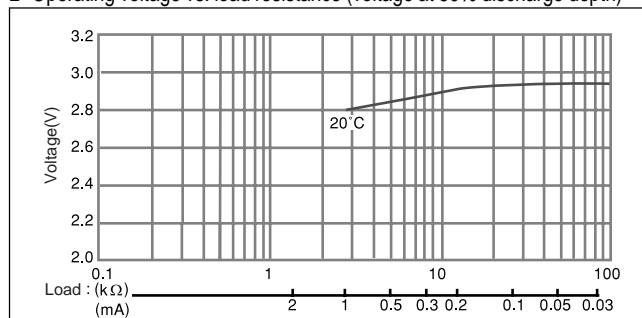

□ Capacity vs. load resistance

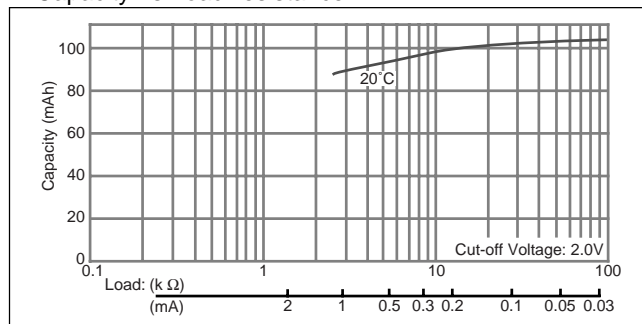

Manganese Dioxide Lithium Coin Batteries: Individual Specifications

CR2450

■ Dimensions(mm)

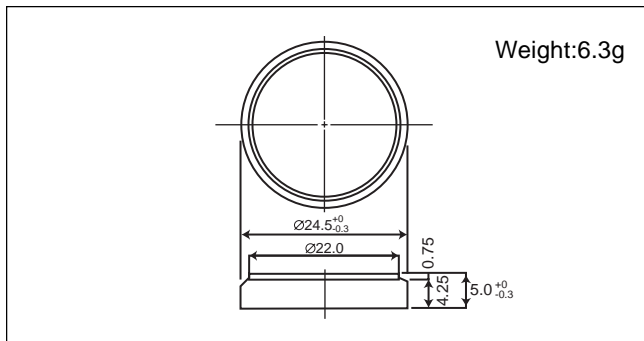

■ Specification

Nominal voltage (V)	3
Nominal capacity (mAh)	620
Continuous standard load (mA)	0.2
Operating temperature (C)	-30 ~ +60

■ Temperature Characteristics

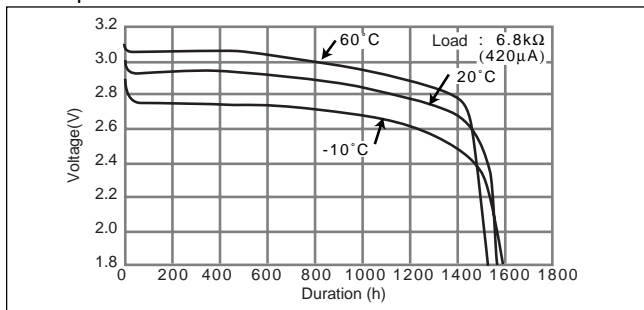

■ Operating voltage vs. load resistance (voltage at 50% discharge depth)

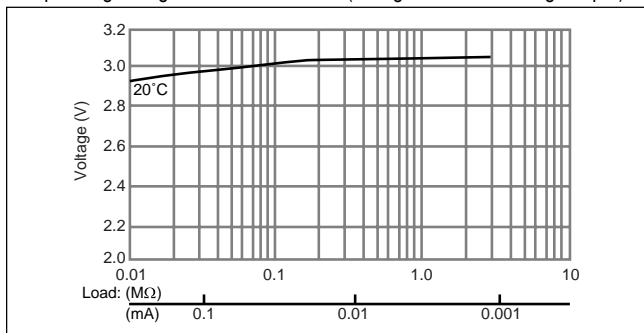

■ Capacity vs. load resistance

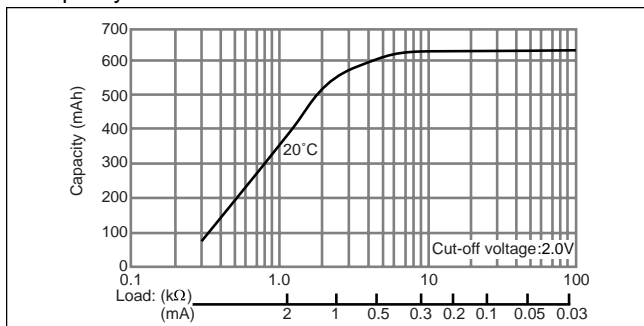

CR2477

■ Dimensions(mm)

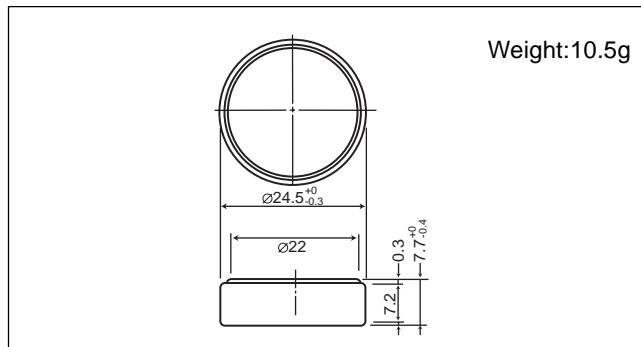

■ Specification

Nominal voltage (V)	3
Nominal capacity (mAh)	1,000
Continuous standard load (mA)	0.2
Operating temperature (C)	-30 ~ +60

■ Temperature Characteristics

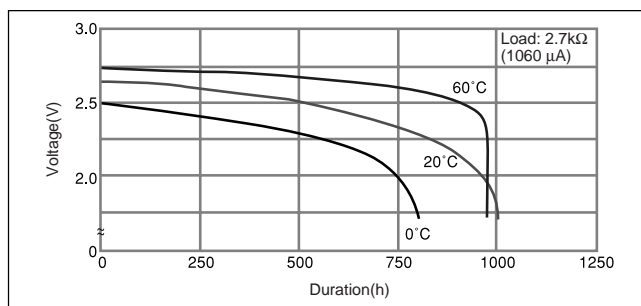

■ Operating voltage vs. load resistance (voltage at 50% discharge depth)

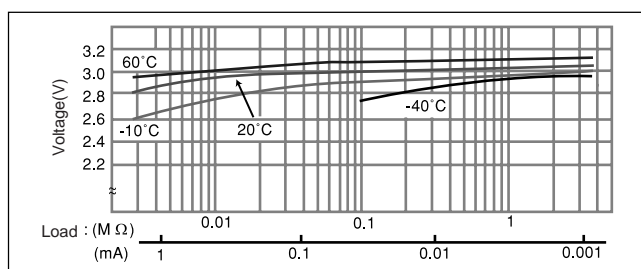

■ Capacity vs. load resistance

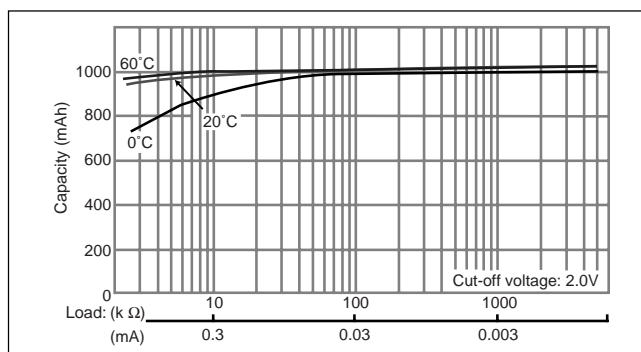

Manganese Dioxide Lithium Coin Batteries: Individual Specifications

CR2450

■ Dimensions(mm)

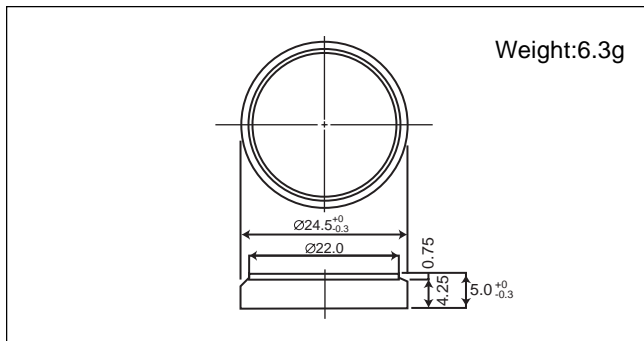

■ Specification

Nominal voltage (V)	3
Nominal capacity (mAh)	620
Continuous standard load (mA)	0.2
Operating temperature (C)	-30 ~ +60

■ Temperature Characteristics

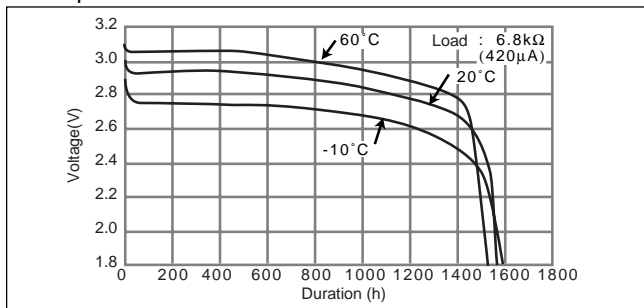

■ Operating voltage vs. load resistance (voltage at 50% discharge depth)

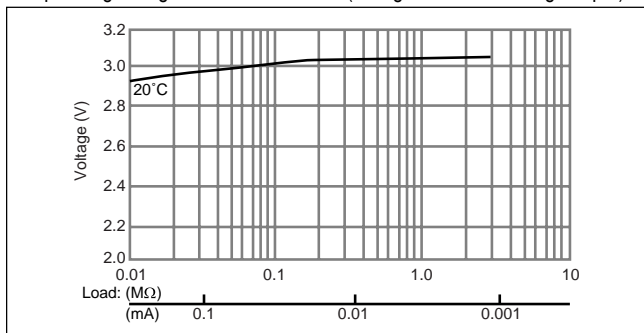

■ Capacity vs. load resistance

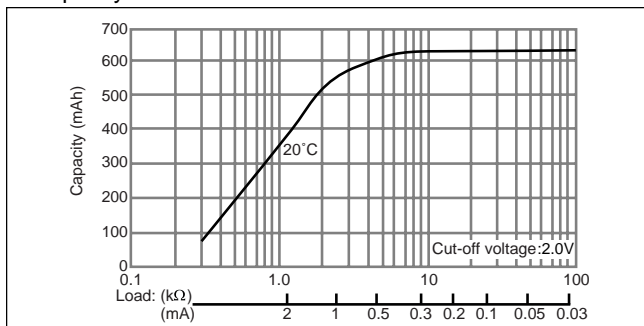

CR2477

■ Dimensions(mm)

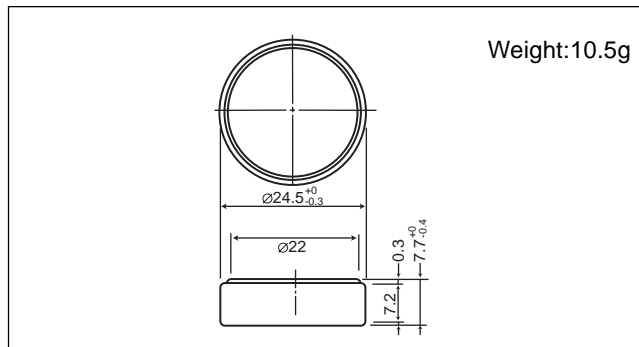

■ Specification

Nominal voltage (V)	3
Nominal capacity (mAh)	1,000
Continuous standard load (mA)	0.2
Operating temperature (C)	-30 ~ +60

■ Temperature Characteristics

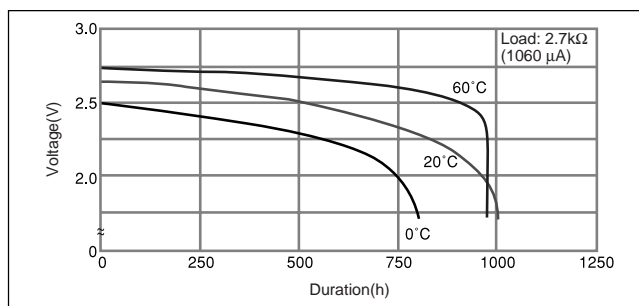

■ Operating voltage vs. load resistance (voltage at 50% discharge depth)

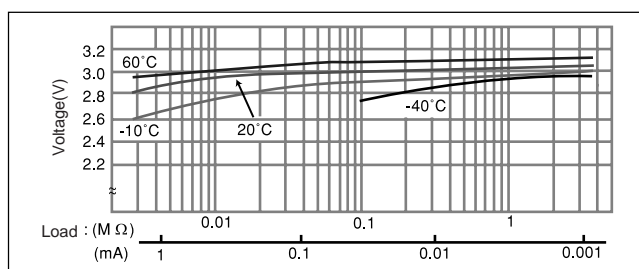

■ Capacity vs. load resistance

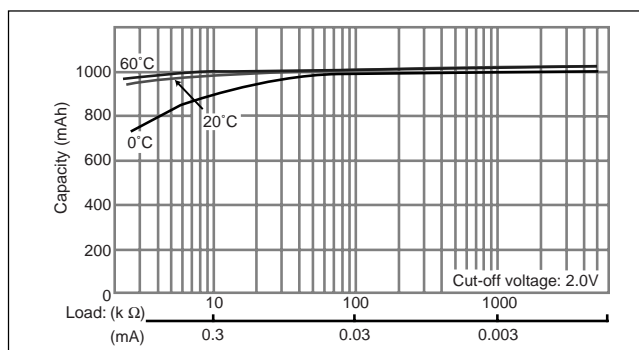

Manganese Dioxide Lithium Coin Batteries: Individual Specifications

CR3032

□ Dimensions(mm)

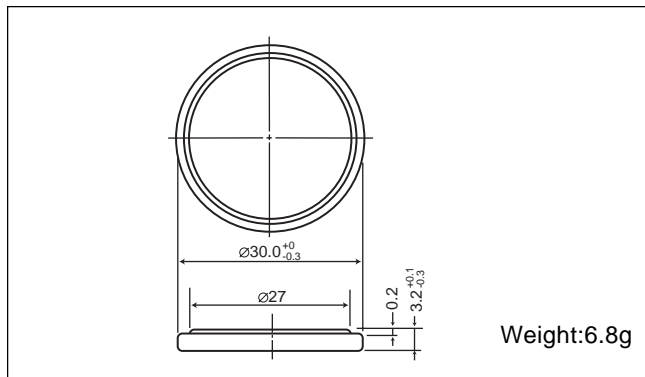

□ Specification

Nominal voltage (V)	3
Nominal capacity (mAh)	500
Continuous standard load (mA)	0.2
Operating temperature (C)	-30 ~ +60

□ Temperature Characteristics

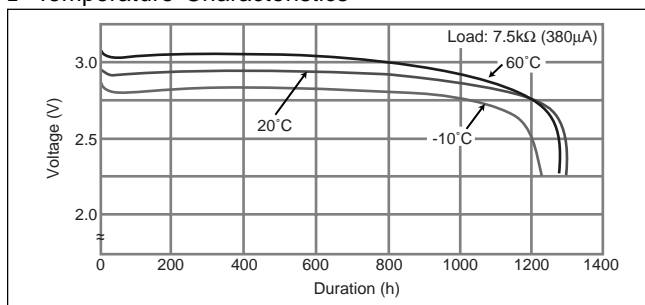

□ Operating voltage vs. load resistance (voltage at 50% discharge depth)

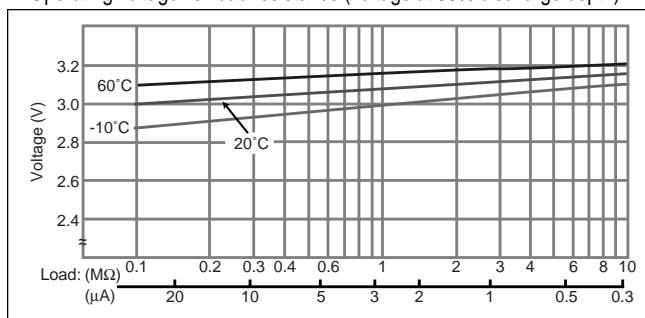

□ Capacity vs. load resistance

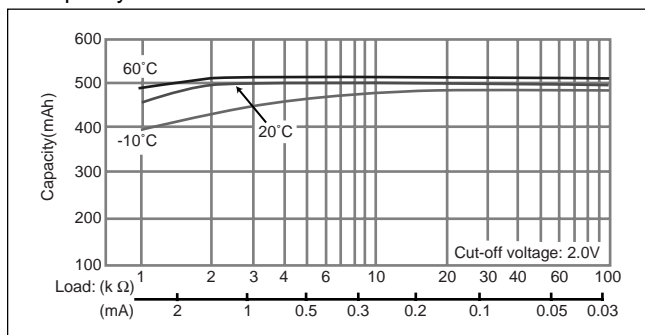



Компания «ЭлектроПласт» предлагает заключение долгосрочных отношений при поставках импортных электронных компонентов на взаимовыгодных условиях!

Наши преимущества:

- Оперативные поставки широкого спектра электронных компонентов отечественного и импортного производства напрямую от производителей и с крупнейших мировых складов;
- Поставка более 17-ти миллионов наименований электронных компонентов;
- Поставка сложных, дефицитных, либо снятых с производства позиций;
- Оперативные сроки поставки под заказ (от 5 рабочих дней);
- Экспресс доставка в любую точку России;
- Техническая поддержка проекта, помощь в подборе аналогов, поставка прототипов;
- Система менеджмента качества сертифицирована по Международному стандарту ISO 9001;
- Лицензия ФСБ на осуществление работ с использованием сведений, составляющих государственную тайну;
- Поставка специализированных компонентов (Xilinx, Altera, Analog Devices, Intersil, Interpoint, Microsemi, Aeroflex, Peregrine, Syfer, Eurofarad, Texas Instrument, Miteq, Cobham, E2V, MA-COM, Hittite, Mini-Circuits, General Dynamics и др.);

Помимо этого, одним из направлений компании «ЭлектроПласт» является направление «Источники питания». Мы предлагаем Вам помощь Конструкторского отдела:

- Подбор оптимального решения, техническое обоснование при выборе компонента;
- Подбор аналогов;
- Консультации по применению компонента;
- Поставка образцов и прототипов;
- Техническая поддержка проекта;
- Защита от снятия компонента с производства.



Как с нами связаться

Телефон: 8 (812) 309 58 32 (многоканальный)

Факс: 8 (812) 320-02-42

Электронная почта: org@eplast1.ru

Адрес: 198099, г. Санкт-Петербург, ул. Калинина, дом 2, корпус 4, литера А.