

FEATURES

- Guaranteed monotonic
- INL error: ± 4 LSB max
- On-chip 1.25 V/2.5 V, 10 ppm/ $^{\circ}$ C reference
- Temperature range: -40° C to $+85^{\circ}$ C
- Rail-to-rail output amplifier
- Power-down mode
- Package type: 100-lead LQFP (14 mm \times 14 mm)
- User interfaces:
 - Parallel
 - Serial (SPI[®]-/QSPI[™]-/MICROWIRE[™]-/DSP-compatible, featuring data readback)
 - I²C-compatible
- Robust 6.5 kV HBM and 2 kV FICDM ESD rating

INTEGRATED FUNCTIONS

- Channel monitor
- Simultaneous output update via $\overline{\text{LDAC}}$
- Clear function to user-programmable code
- Amplifier boost mode to optimize slew rate
- User-programmable offset and gain adjust
- Toggle mode enables square wave generation
- Thermal monitor

APPLICATIONS

- Variable optical attenuators (VOAs)
- Level setting (ATE)
- Optical micro-electro-mechanical systems (MEMS)
- Control systems
- Instrumentation

FUNCTIONAL BLOCK DIAGRAM

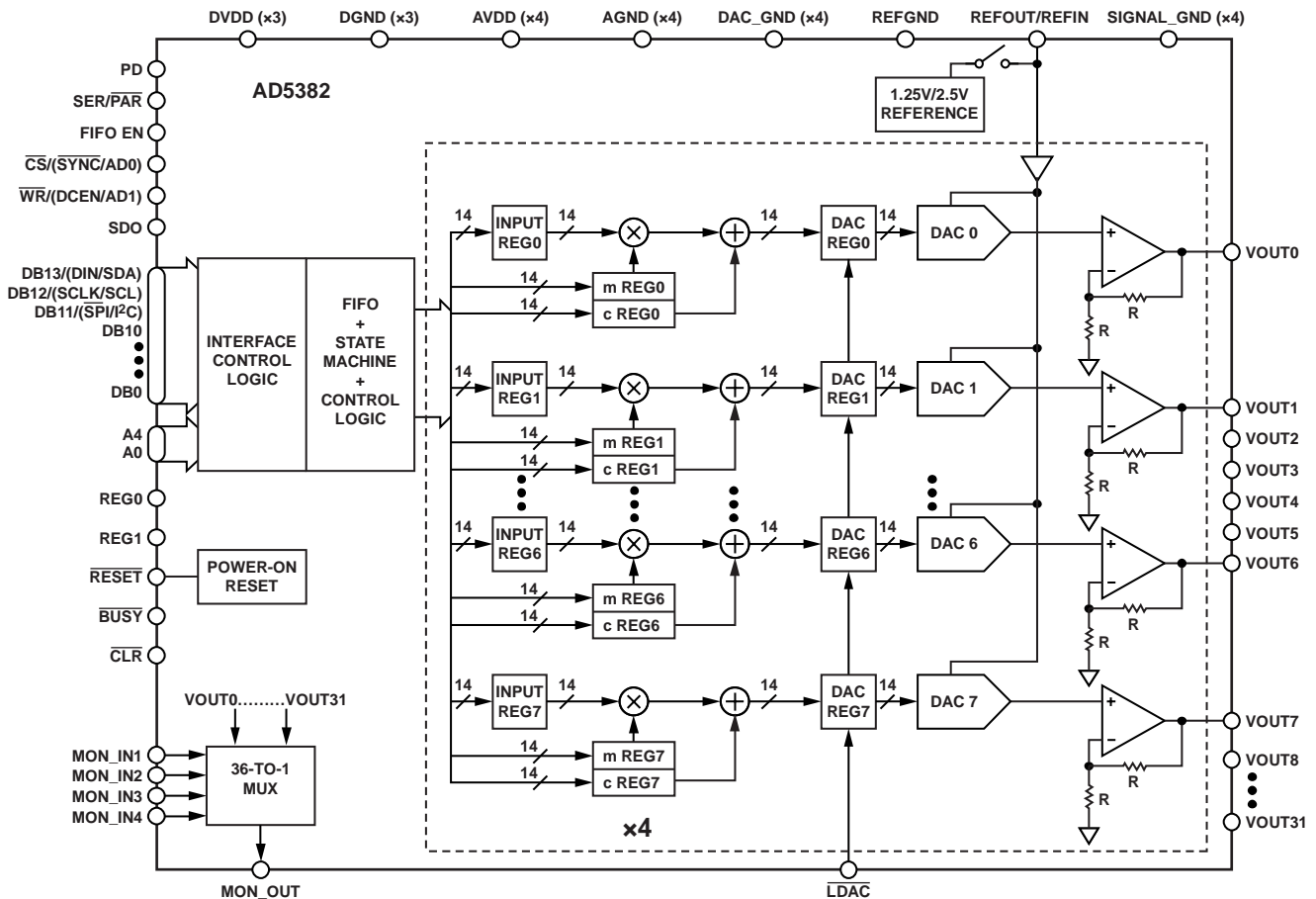

Figure 1.

Rev. C

Information furnished by Analog Devices is believed to be accurate and reliable. However, no responsibility is assumed by Analog Devices for its use, nor for any infringements of patents or other rights of third parties that may result from its use. Specifications subject to change without notice. No license is granted by implication or otherwise under any patent or patent rights of Analog Devices. Trademarks and registered trademarks are the property of their respective owners.

TABLE OF CONTENTS

General Description	3	Asynchronous Clear Function.....	25
Specifications.....	4	$\overline{\text{BUSY}}$ and $\overline{\text{LDAC}}$ Functions.....	25
AD5382-5 Specifications	4	FIFO Operation in Parallel Mode	25
AD5382-3 Specifications	6	Power-On Reset	25
AC Characteristics.....	7	Power-Down	25
Timing Characteristics.....	8	AD5382 Interfaces.....	26
SPI-, QSPI-, MICROWIRE-, or DSP-Compatible Serial Interface	8	DSP-, SPI-, MICROWIRE-Compatible Serial Interfaces	26
I ² C Serial Interface.....	10	I ² C Serial Interface	28
Parallel Interface	11	Parallel Interface.....	30
Absolute Maximum Ratings.....	13	Microprocessor Interfacing.....	31
ESD Caution.....	13	Application Information.....	33
Pin Configuration and Function Descriptions.....	14	Power Supply Decoupling	33
Terminology	17	Typical Configuration Circuit	33
Typical Performance Characteristics	18	Monitor Function	34
Functional Description	21	Toggle Mode Function.....	34
DAC Architecture—General.....	21	Thermal Monitor Function.....	35
Data Decoding	21	AD5382 in a MEMS-Based Optical Switch	35
On-Chip Special Function Registers (SFR)	22	Optical Attenuators.....	36
SFR Commands	22	Outline Dimensions	37
Hardware Functions.....	25	Ordering Guide	37
Reset Function	25		

REVISION HISTORY

10/12—Rev. B to Rev. C

Changes to Title and Features Section.....	1
Changes to General Description and Table 1	3
Deleted Table 2; Renumbered Sequentially.....	3
Changes to Table 2.....	4
Changes to Table 3.....	6
Changes to Output Voltage Settling Time and Slew Rate Parameters, Table 4.....	7
Changes to t_{14} , t_{17} , and t_{19} Parameters, Table 5	8
Change to t_{18} Parameter, Table 7.....	11
Changes to Table 8 and ESD Caution Section	13
Changes to Figure 10, Figure 11, and Figure 14; Deleted Figure 13; Renumbered Sequentially	18

Changes to Figure 16, Figure 18, and Figure 19.....	19
Change to Table 13	22
Updated Outline Dimensions.....	37

4/10—Rev. A to Rev. B

Changes to Table 18	24
Changes to Ordering Guide	37

3/05—Rev. 0 to Rev. A

Changes to Specifications.....	4
Changes to Figure 43.....	35

5/04—Revision 0: Initial Version

GENERAL DESCRIPTION

The AD5382 is a complete, single-supply, 32-channel, 14-bit *denseDAC*® available in a 100-lead LQFP package. All 32 channels have an on-chip output amplifier with rail-to-rail operation. The AD5382 includes an internal software-selectable 1.25 V/2.5 V, 10 ppm/°C reference, an on-chip channel monitor function that multiplexes the analog outputs to a common MON_OUT pin for external monitoring, and an output amplifier boost mode that allows optimization of the amplifier slew rate.

The AD5382 contains a double-buffered parallel interface, which features a 20 ns \overline{WR} pulse width, an SPI-, QSPI-, MICROWIRE-, DSP-compatible serial interface with interface speeds in excess of 30 MHz and an I²C®-compatible

interface that supports a 400 kHz data transfer rate.

An input register followed by a DAC register provides double buffering, allowing the DAC outputs to be updated independently or simultaneously using the \overline{LDAC} input.

Each channel has a programmable gain and offset adjust register that allows the user to fully calibrate any DAC channel. Power consumption is typically 0.25 mA/channel when operating with boost mode disabled.

Table 1. Other High Channel Count, Low Voltage, Single Supply DACs in Product Portfolio

Model	Resolution	AVDD Range	Output Channels	Linearity Error (LSB)	Package Description	Package Option
AD5380BSTZ-5	14 Bits	4.5 V to 5.5 V	40	±4	100-Lead LQFP	ST-100
AD5380BSTZ-3	14 Bits	2.7 V to 3.6 V	40	±4	100-Lead LQFP	ST-100
AD5381BSTZ-5	12 Bits	4.5 V to 5.5 V	40	±1	100-Lead LQFP	ST-100
AD5381BSTZ-3	12 Bits	2.7 V to 3.6 V	40	±1	100-Lead LQFP	ST-100
AD5383BSTZ-5	12 Bits	4.5 V to 5.5 V	32	±1	100-Lead LQFP	ST-100
AD5383BSTZ-3	12 Bits	2.7 V to 3.6 V	32	±1	100-Lead LQFP	ST-100
AD5390BSTZ-5	14 Bits	4.5 V to 5.5 V	16	±3	52-Lead LQFP	ST-52
AD5390BCPZ-5	14 Bits	4.5 V to 5.5 V	16	±3	64-Lead LFCSP	CP-64
AD5390BSTZ-3	14 Bits	2.7 V to 3.6 V	16	±4	52-Lead LQFP	ST-52
AD5390BCPZ-3	14 Bits	2.7 V to 3.6 V	16	±4	64-Lead LFCSP	CP-64
AD5391BSTZ-5	12 Bits	4.5 V to 5.5 V	16	±1	52-Lead LQFP	ST-52
AD5391BCPZ-5	12 Bits	4.5 V to 5.5 V	16	±1	64-Lead LFCSP	CP-64
AD5391BSTZ-3	12 Bits	2.7 V to 3.6 V	16	±1	52-Lead LQFP	ST-52
AD5391BCPZ-3	12 Bits	2.7 V to 3.6 V	16	±1	64-Lead LFCSP	CP-64
AD5392BSTZ-5	14 Bits	4.5 V to 5.5 V	8	±3	52-Lead LQFP	ST-52
AD5392BCPZ-5	14 Bits	4.5 V to 5.5 V	8	±3	64-Lead LFCSP	CP-64
AD5392BSTZ-3	14 Bits	2.7 V to 3.6 V	8	±4	52-Lead LQFP	ST-52
AD5392BCPZ-3	14 Bits	2.7 V to 3.6 V	8	±4	64-Lead LFCSP	CP-64

SPECIFICATIONS

AD5382-5 SPECIFICATIONS

AVDD = 4.5 V to 5.5 V; DVDD = 2.7 V to 5.5 V, AGND = DGND = 0 V; External REFIN = 2.5 V; all specifications T_{MIN} to T_{MAX} , unless otherwise noted.

Table 2.

Parameter	AD5382-5 ¹	Unit	Test Conditions/Comments
ACCURACY			
Resolution	14	Bits	
Relative Accuracy ² (INL)	±4	LSB max	
Differential Nonlinearity (DNL)	-1/+2	LSB max	Guaranteed monotonic over temperature
Zero-Scale Error	4	mV max	
Offset Error	±4	mV max	Measured at Code 32 in the linear region
Offset Error TC	±5	µV/°C typ	
Gain Error	±0.05	% FSR max	At 25°C
	±0.06	% FSR max	T_{MIN} to T_{MAX}
Gain Temperature Coefficient ³	2	ppm FSR/°C typ	
DC Crosstalk ³	1	LSB max	
REFERENCE INPUT/OUTPUT			
Reference Input ³			
Reference Input Voltage	2.5	V	±1% for specified performance, AVDD = 2xREFIN + 50 mV
DC Input Impedance	1	MΩ min	Typically 100 MΩ
Input Current	±1	µA max	Typically ±30 nA
Reference Range	1 to AVDD/2	V min/max	
Reference Output ⁴			
Output Voltage	2.495/2.505	V min/max	Enabled via CR10 in the AD5382 control register; CR12 selects the reference voltage
	1.22/1.28	V min/max	At ambient; CR12 = 1; optimized for 2.5 V operation
Reference TC	±10	ppm/°C max	1.25 V reference selected; CR12 = 0
	±15	ppm/°C max	Temperature range: +25°C to +85°C
Output Impedance	800	Ω typ	Temperature range: -40°C to +85°C
OUTPUT CHARACTERISTICS³			
Output Voltage Range ²	0/AVDD	V min/max	
Short-Circuit Current	40	mA max	
Load Current	±1	mA max	
Capacitive Load Stability			
$R_L = \infty$	200	pF max	
$R_L = 5 \text{ k}\Omega$	1000	pF max	
DC Output Impedance	0.6	Ω max	
MONITOR PIN			
Output Impedance	1	kΩ typ	
Three-State Leakage Current	100	nA typ	
LOGIC INPUTS (EXCEPT SDA/SCL)³			
V_{IH} , Input High Voltage	2	V min	DVDD = 2.7 V to 5.5 V
V_{IL} , Input Low Voltage			
DVDD > 3.6 V	0.8	V max	
DVDD ≤ 3.6 V	0.6	V max	
Input Current	±1	µA max	
Pin Capacitance	10	pF max	Total for all pins, $T_A = T_{MIN}$ to T_{MAX}

Parameter	AD5382-5 ¹	Unit	Test Conditions/Comments
LOGIC INPUTS (SDA, SCL ONLY)³			
V _{IH} , Input High Voltage	0.7 × DVDD	V min	SMBus-compatible at DVDD < 3.6 V
V _{IL} , Input Low Voltage	0.3 × DVDD	V max	SMBus-compatible at DVDD < 3.6 V
I _{IN} , Input Leakage Current	±1	μA max	
V _{HYST} , Input Hysteresis	0.05 × DVDD	V min	
C _{IN} , Input Capacitance	8	pF typ	
Glitch Rejection	50	ns max	Input filtering suppresses noise spikes of less than 50 ns
LOGIC OUTPUTS (BUSY, SDO)³			
V _{OL} , Output Low Voltage	0.4	V max	DVDD = 5 V ± 10%, sinking 200 μA
V _{OH} , Output High Voltage	DVDD – 1	V min	DVDD = 5 V ± 10%, sourcing 200 μA
V _{OL} , Output Low Voltage	0.4	V max	DVDD = 2.7 V to 3.6 V, sinking 200 μA
V _{OH} , Output High Voltage	DVDD – 0.5	V min	DVDD = 2.7 V to 3.6 V, sourcing 200 μA
High Impedance Leakage Current	±1	μA max	SDO only
High Impedance Output Capacitance	5	pF typ	SDO only
LOGIC OUTPUT (SDA)³			
V _{OL} , Output Low Voltage	0.4	V max	I _{SINK} = 3 mA
	0.6	V max	I _{SINK} = 6 mA
Three-State Leakage Current	±1	μA max	
Three-State Output Capacitance	8	pF typ	
POWER REQUIREMENTS			
AVDD	4.5/5.5	V min/max	
DVDD	2.7/5.5	V min/max	
Power Supply Sensitivity ³			
ΔMidscale/ΔAV _{DD}	–85	dB typ	
A _{DD}	0.375	mA/channel max	Outputs unloaded, boost off. 0.25 mA/channel typ
	0.475	mA/channel max	Outputs unloaded, boost on. 0.325 mA/channel typ
D _{DD}	1	mA max	V _{IH} = DVDD, V _{IL} = DGND.
A _{DD} (Power-Down)	20	μA max	Typically 100 nA
D _{DD} (Power-Down)	20	μA max	Typically 1 μA
Power Dissipation	65	mW max	Outputs unloaded, boost off, AVDD = DVDD = 5 V

¹ AD5382-5 is calibrated using an external 2.5 V reference. Temperature range for all versions: –40°C to +85°C.

² Accuracy guaranteed from V_{OUT} = 10 mV to AVDD – 50 mV.

³ Guaranteed by characterization, not production tested.

⁴ Default on the AD5382-5 is 2.5 V. Programmable to 1.25 V via CR12 in the AD5382 control register; operating the AD5382-5 with a 1.25 V reference leads to degraded accuracy specifications.

AD5382-3 SPECIFICATIONS

AVDD = 2.7 V to 3.6 V; DVDD = 2.7 V to 5.5 V, AGND = DGND = 0 V; external REFIN = 1.25 V; all specifications T_{MIN} to T_{MAX}, unless otherwise noted.

Table 3.

Parameter	AD5382-3 ¹	Unit	Test Conditions/Comments
ACCURACY			
Resolution	14	Bits	
Relative Accuracy ² (INL)	±4	LSB max	
Differential Nonlinearity (DNL)	-1/+2	LSB max	Guaranteed monotonic over temperature
Zero-Scale Error	4	mV max	
Offset Error	±4	mV max	Measured at Code 64 in the linear region
Offset Error TC	±5	µV/°C typ	
Gain Error	±0.05	% FSR max	At 25°C
	±0.1	% FSR max	T _{MIN} to T _{MAX}
Gain Temperature Coefficient ³	2	ppm FSR/°C typ	
DC Crosstalk ³	1	LSB max	
REFERENCE INPUT/OUTPUT			
Reference Input ³			
Reference Input Voltage	1.25	V	±1% for specified performance
DC Input Impedance	1	MΩ min	Typically 100 MΩ
Input Current	±10	µA max	Typically ±30 nA
Reference Range	1 to AVDD/2	V min/max	
Reference Output ⁴			
Output Voltage	1.245/1.255 2.47/2.53	V min/max V min/max	Enabled via CR10 in the AD5382 control register, CR12 selects the reference voltage At ambient; CR12 = 0; optimized for 1.25 V operation 2.5 V reference selected; CR12 = 1
Reference TC	±10 ±15	ppm/°C max ppm/°C max	Temperature Range: +25°C to +85°C Temperature Range: -40°C to +85°C
Output Impedance	800	Ω typ	
OUTPUT CHARACTERISTICS³			
Output Voltage Range ²	0/AVDD	V min/max	
Short-Circuit Current	40	mA max	
Load Current	±1	mA max	
Capacitive Load Stability			
R _L = ∞	200	pF max	
R _L = 5 kΩ	1000	pF max	
DC Output Impedance	0.6	Ω max	
MONITOR PIN (MON OUT)			
Output Impedance	1	kΩ typ	
Three-State Leakage Current	100	nA typ	
LOGIC INPUTS (EXCEPT SDA/SCL)³			
V _{IH} , Input High Voltage	2	V min	DVDD = 2.7 V to 3.6 V
V _{IL} , Input Low Voltage			
DVDD > 3.6 V	0.8	V max	
DVDD ≤ 3.6 V	0.6	V max	
Input Current	±1	µA max	Total for all pins, T _A = T _{MIN} to T _{MAX}
Pin Capacitance	10	pF max	
LOGIC INPUTS (SDA, SCL ONLY)³			
V _{IH} , Input High Voltage	0.7 × DVDD	V min	SMBus-compatible at DVDD < 3.6 V
V _{IL} , Input Low Voltage	0.3 × DVDD	V max	SMBus-compatible at DVDD < 3.6 V
I _{IN} , Input Leakage Current	±1	µA max	
V _{HYST} , Input Hysteresis	0.05 × DVDD	V min	
C _{IN} , Input Capacitance	8	pF typ	
Glitch Rejection	50	ns max	Input filtering suppresses noise spikes of less than 50 ns

Parameter	AD5382-3 ¹	Unit	Test Conditions/Comments
LOGIC OUTPUTS (BUSY, SDO) ³			
V _{OL} , Output Low Voltage	0.4	V max	Sinking 200 μA
V _{OH} , Output High Voltage	DVDD – 0.5	V min	Sourcing 200 μA
High Impedance Leakage Current	±1	μA max	SDO only
High Impedance Output Capacitance	5	pF typ	SDO only
LOGIC OUTPUT (SDA) ³			
V _{OL} , Output Low Voltage	0.4	V max	I _{SINK} = 3 mA
	0.6	V max	I _{SINK} = 6 mA
Three-State Leakage Current	±1	μA max	
Three-State Output Capacitance	8	pF typ	
POWER REQUIREMENTS			
AVDD	2.7/3.6	V min/max	
DVDD	2.7/5.5	V min/max	
Power Supply Sensitivity ³			
ΔMidscale/ΔAVDD	–85	dB typ	
A _{DD}	0.375	mA/channel max	Outputs unloaded; boost off; 0.25 mA/channel typ
	0.475	mA/channel max	Outputs unloaded; boost on; 0.325 mA/channel typ
D _{DD}	1	mA max	V _{IH} = DVDD V _{IL} = DGND
A _{DD} (Power-Down)	20	μA max	Typically 100 nA
D _{DD} (Power-Down)	20	μA max	Typically 1 μA
Power Dissipation	39	mW max	Outputs unloaded; boost off; AVDD = DVDD = 3 V

¹ AD5382-3 is calibrated using an external 1.25 V reference. Temperature range is –40°C to +85°C.

² Accuracy guaranteed from VOUT = 10 mV to AVDD – 50 mV.

³ Guaranteed by characterization, not production tested.

⁴ Default on the AD5382-5 is 2.5 V. Programmable to 1.25 V via CR12 in the AD5382 control register; operating the AD5382-5 with a 1.25 V reference leads to degraded accuracy specifications.

AC CHARACTERISTICS¹

AVDD = 4.5 V to 5.5 V or 2.7 V to 3.6 V; DVDD = 2.7 V to 5.5 V; AGND = DGND = 0 V.

Table 4.

Parameter	All	Unit	Test Conditions/Comments
DYNAMIC PERFORMANCE			
Output Voltage Settling Time ²			1/4 scale to 3/4 scale change settling to ±1 LSB
	3	μs typ	
	8	μs max	
Slew Rate ²	1.5	V/μs typ	Boost mode off, CR11 = 0
	2.5	V/μs typ	Boost mode on, CR11 = 1
Digital-to-Analog Glitch Energy	12	nV-s typ	
Glitch Impulse Peak Amplitude	15	mV typ	
DAC-to-DAC Crosstalk	1	nV-s typ	See Terminology section
Digital Crosstalk	0.8	nV-s typ	
Digital Feedthrough	0.1	nV-s typ	Effect of input bus activity on DAC output under test
Output Noise 0.1 Hz to 10 Hz	15	μV p-p typ	External reference, midscale loaded to DAC
	40	μV p-p typ	Internal reference, midscale loaded to DAC
Output Noise Spectral Density			
at 1 kHz	150	nV/√Hz typ	
at 10 kHz	100	nV/√Hz typ	

¹ Guaranteed by design and characterization, not production tested.

² The slew rate can be programmed via the current boost control bit (CR11) in the AD5382 control register.

TIMING CHARACTERISTICS

SPI-, QSPI-, MICROWIRE-, OR DSP-COMPATIBLE SERIAL INTERFACE

DVDD = 2.7 V to 5.5 V; AVDD = 4.5 V to 5.5 V or 2.7 V to 3.6 V; AGND = DGND = 0 V; all specifications T_{MIN} to T_{MAX} , unless otherwise noted.

Table 5.

Parameter ^{1, 2, 3}	Limit at T_{MIN} , T_{MAX}	Unit	Description
t_1	33	ns min	SCLK cycle time
t_2	13	ns min	SCLK high time
t_3	13	ns min	SCLK low time
t_4	13	ns min	\overline{SYNC} falling edge to SCLK falling edge setup time
t_5^4	13	ns min	24th SCLK falling edge to \overline{SYNC} falling edge
t_6^4	33	ns min	Minimum \overline{SYNC} low time
t_7	10	ns min	Minimum \overline{SYNC} high time
t_{7A}	50	ns min	Minimum \overline{SYNC} high time in readback mode
t_8	5	ns min	Data setup time
t_9	4.5	ns min	Data hold time
t_{10}^4	30	ns max	24th SCLK falling edge to \overline{BUSY} falling edge
t_{11}	670	ns max	\overline{BUSY} pulse width low (single channel update)
t_{12}^4	20	ns min	24th SCLK falling edge to \overline{LDAC} falling edge
t_{13}	20	ns min	\overline{LDAC} pulse width low
t_{14}	2	μ s max	\overline{BUSY} rising edge to DAC output response time
t_{15}	0	ns min	\overline{BUSY} rising edge to \overline{LDAC} falling edge
t_{16}	100	ns min	\overline{LDAC} falling edge to DAC output response time
t_{17}	2	μ s typ	DAC output settling time
t_{18}	20	ns min	\overline{CLR} pulse width low
t_{19}	40	μ s max	\overline{CLR} pulse activation time
t_{20}^5	20	ns max	SCLK rising edge to SDO valid
t_{21}^5	5	ns min	SCLK falling edge to \overline{SYNC} rising edge
t_{22}^5	8	ns min	\overline{SYNC} rising edge to SCLK rising edge
t_{23}	20	ns min	\overline{SYNC} rising edge to \overline{LDAC} falling edge

¹ Guaranteed by design and characterization, not production tested.

² All input signals are specified with $t_r = t_f = 5$ ns (10% to 90% of V_{CC}) and are timed from a voltage level of 1.2 V.

³ See Figure 2, Figure 3, Figure 4, and Figure 5.

⁴ Standalone mode only.

⁵ Daisy-chain mode only.

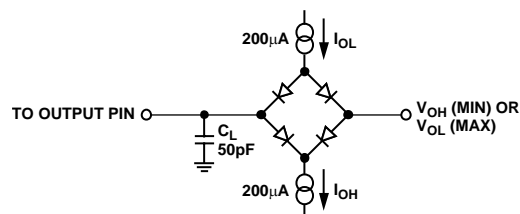

Figure 2. Load Circuit for SDO Timing Diagram (Serial Interface, Daisy-Chain Mode)

03723-002

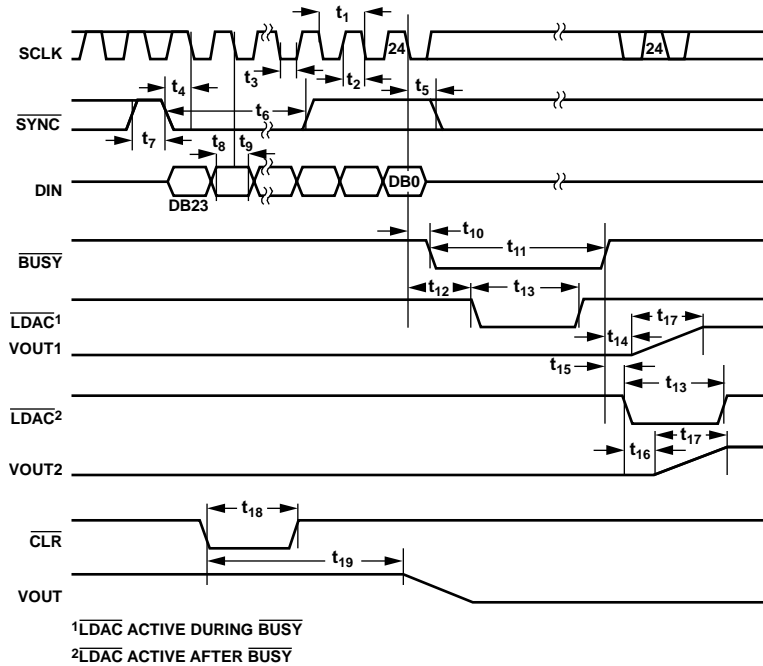

Figure 3. Serial Interface Timing Diagram (Standalone Mode)

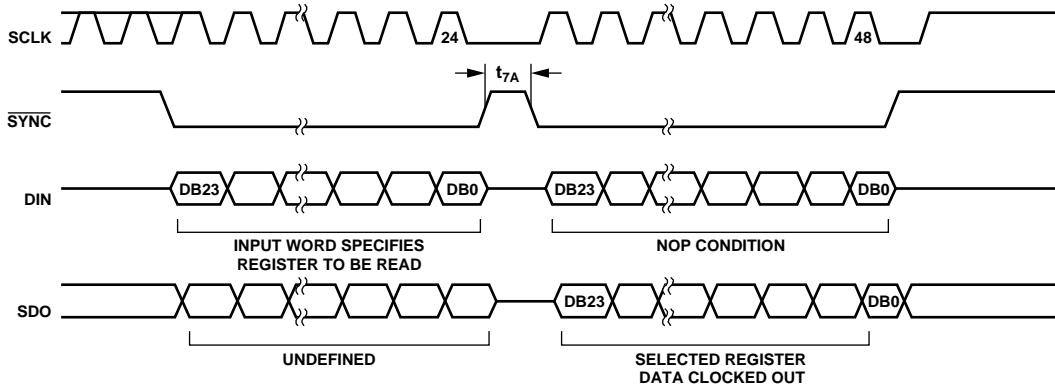

Figure 4. Serial Interface Timing Diagram (Data Readback Mode)

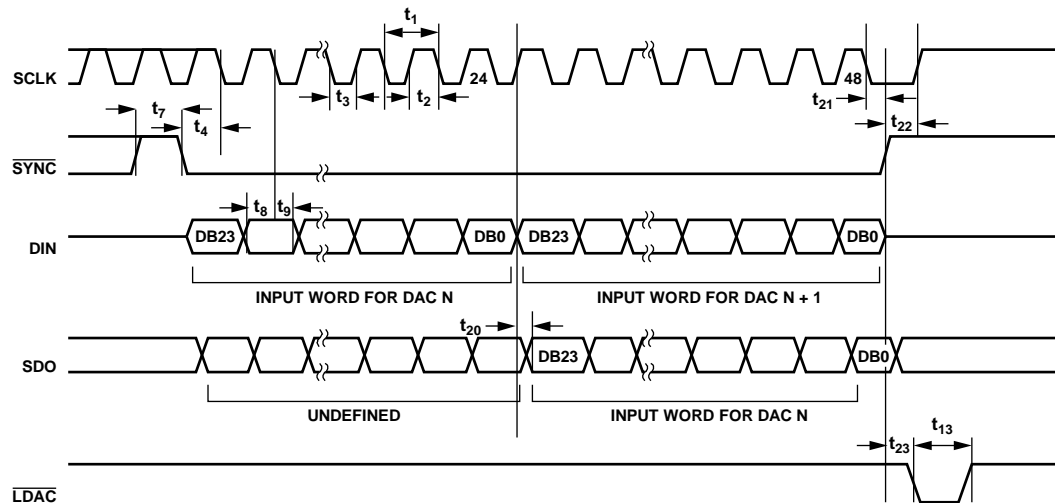

Figure 5. Serial Interface Timing Diagram (Daisy-Chain Mode)

I²C SERIAL INTERFACE

DVDD = 2.7 V to 5.5 V; AVDD = 4.5 V to 5.5 V or 2.7 V to 3.6 V; AGND = DGND = 0 V; all specifications T_{MIN} to T_{MAX}, unless otherwise noted.

Table 6.

Parameter ^{1,2}	Limit at T _{MIN} , T _{MAX}	Unit	Description
F _{SCL}	400	kHz max	SCL clock frequency
t ₁	2.5	μs min	SCL cycle time
t ₂	0.6	μs min	t _{HIGH} , SCL high time
t ₃	1.3	μs min	t _{LOW} , SCL low time
t ₄	0.6	μs min	t _{HD,STA} , start/repeated start condition hold time
t ₅	100	ns min	t _{SU,DAT} , data setup time
t ₆ ³	0.9	μs max	t _{HD,DAT} , data hold time
	0	μs min	t _{HD,DAT} , data hold time
t ₇	0.6	μs min	t _{SU,STA} , setup time for repeated start
t ₈	0.6	μs min	t _{SU,STO} , stop condition setup time
t ₉	1.3	μs min	t _{BUF} , bus free time between a stop and a start condition
t ₁₀	300	ns max	t _R , rise time of SCL and SDA when receiving
	0	ns min	t _R , rise time of SCL and SDA when receiving (CMOS-compatible)
t ₁₁	300	ns max	t _F , fall time of SDA when transmitting
	0	ns min	t _F , fall time of SDA when receiving (CMOS-compatible)
	300	ns max	t _F , fall time of SCL and SDA when receiving
	20 + 0.1C _b ⁴	ns min	t _F , fall time of SCL and SDA when transmitting
C _b	400	pF max	Capacitive load for each bus line

¹ Guaranteed by design and characterization, not production tested.

² See Figure 6.

³ A master device must provide a hold time of at least 300 ns for the SDA signal (referred to the V_{H,min} of the SCL signal) in order to bridge the undefined region of SCL's falling edge.

⁴ C_b is the total capacitance, in pF, of one bus line. t_R and t_F are measured between 0.3 DV_{DD} and 0.7 DV_{DD}.

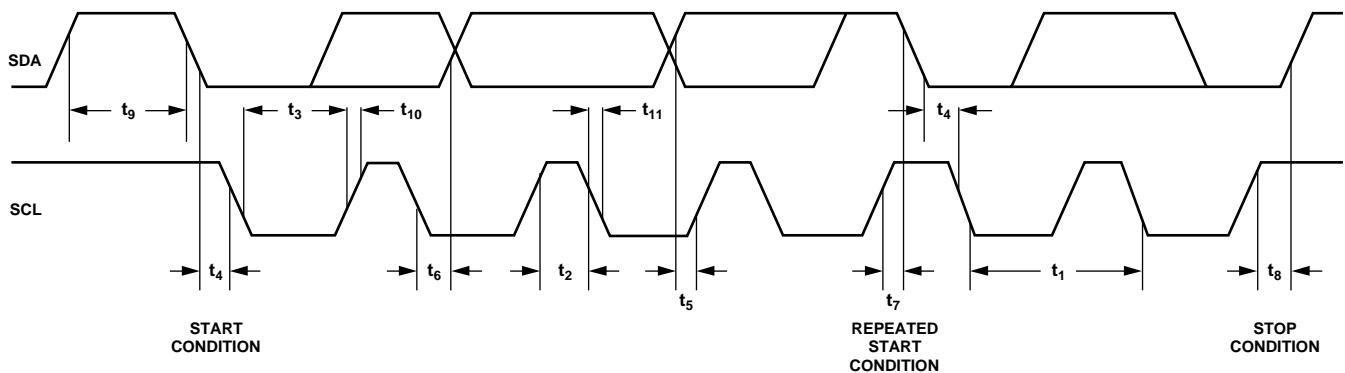
Figure 6. I²C-Compatible Serial Interface Timing Diagram

03773-006

PARALLEL INTERFACE

DVDD = 2.7 V to 5.5 V; AVDD = 4.5 V to 5.5 V or 2.7 V to 3.6 V; AGND = DGND = 0 V; all specifications T_{min} to T_{max}, unless otherwise noted.

Table 7.

Parameter ^{1, 2, 3}	Limit at T _{MIN} , T _{MAX}	Unit	Description
t ₀	4.5	ns min	REG0, REG1, address to \overline{WR} rising edge setup time
t ₁	4.5	ns min	REG0, REG1, address to \overline{WR} rising edge hold time
t ₂	20	ns min	\overline{CS} pulse width low
t ₃	20	ns min	\overline{WR} pulse width low
t ₄	0	ns min	\overline{CS} to \overline{WR} falling edge setup time
t ₅	0	ns min	\overline{WR} to \overline{CS} rising edge hold time
t ₆	4.5	ns min	Data to \overline{WR} rising edge setup time
t ₇	4.5	ns min	Data to \overline{WR} rising edge hold time
t ₈	20	ns min	\overline{WR} pulse width high
t ₉ ⁴	700	ns min	Minimum \overline{WR} cycle time (single-channel write)
t ₁₀ ⁴	30	ns max	\overline{WR} rising edge to \overline{BUSY} falling edge
t ₁₁ ^{4, 5}	670	ns max	\overline{BUSY} pulse width low (single-channel update)
t ₁₂	30	ns min	\overline{WR} rising edge to \overline{LDAC} falling edge
t ₁₃	20	ns min	\overline{LDAC} pulse width low
t ₁₄	100	ns max	\overline{BUSY} rising edge to DAC output response time
t ₁₅	20	ns min	\overline{LDAC} rising edge to \overline{WR} rising edge
t ₁₆	0	ns min	\overline{BUSY} rising edge to \overline{LDAC} falling edge
t ₁₇	100	ns min	\overline{LDAC} falling edge to DAC output response time
t ₁₈	2	μs typ	DAC output settling time
t ₁₉	20	ns min	\overline{CLR} pulse width low
t ₂₀	35	μsmax	\overline{CLR} pulse activation time

¹ Guaranteed by design and characterization, not production tested.

² All input signals are specified with t_r = t_f = 5 ns (10% to 90% of DV_{DD}) and timed from a voltage level of 1.2 V.

³ See Figure 7.

⁴ See Figure 28.

⁵ Measured with the load circuit of Figure 2.

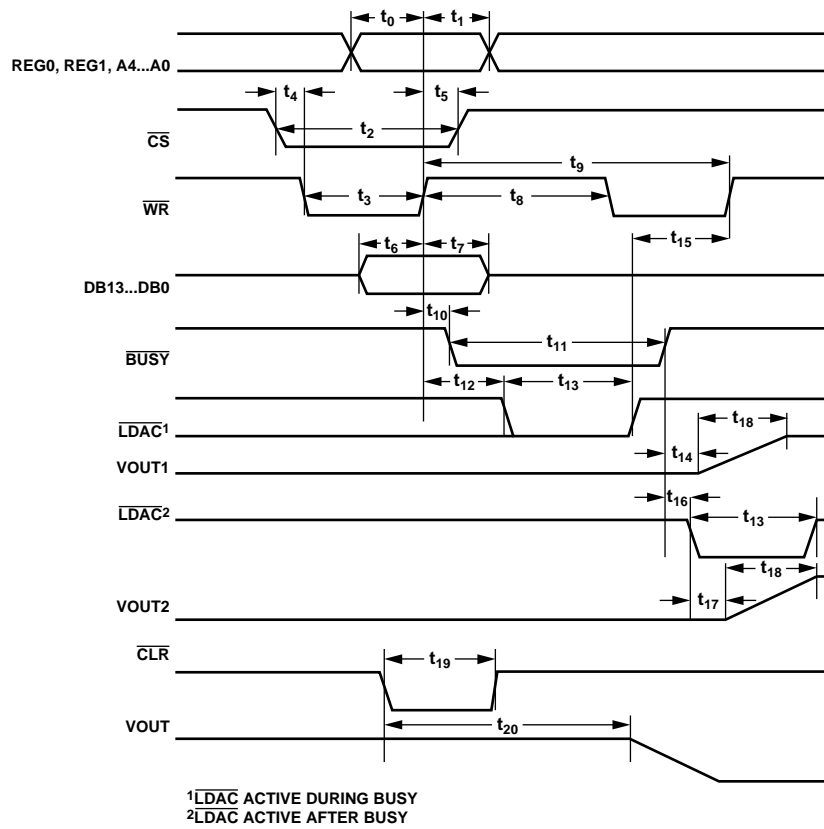

037533-007

Figure 7. Parallel Interface Timing Diagram

ABSOLUTE MAXIMUM RATINGS

$T_A = 25^\circ\text{C}$, unless otherwise noted¹.

Table 8.

Parameter	Rating
AVDD to AGND	-0.3 V to +7 V
DVDD to DGND	-0.3 V to +7 V
Digital Inputs to DGND	-0.3 V to DVDD + 0.3 V
SDA/SCL to DGND	-0.3 V to +7 V
Digital Outputs to DGND	-0.3 V to DVDD + 0.3 V
REFIN/REFOUT to AGND	-0.3 V to AVDD + 0.3 V
AGND to DGND	-0.3 V to +0.3 V
VOUTx to AGND	-0.3 V to AVDD+ 0.3 V
Analog Inputs to AGND	-0.3 V to AVDD + 0.3 V
MON_IN Inputs to AGND	-0.3 V to AVDD + 0.3 V
MON_OUT to AGND	-0.3 V to AVDD + 0.3 V
Operating Temperature Range	
Commercial (B Version)	-40°C to +85°C
Storage Temperature Range	-65°C to +150°C
JunctionTemperature (T_J max)	150°C
100-lead LQFP Package	
θ_{JA} Thermal Impedance	44°C/W
Reflow Soldering	
Peak Temperature	230°C
ESD	
HBM	6.5 kV
FICDM	2 kV

¹ Transient currents of up to 100 mA do not cause SCR latch-up.

Stresses above those listed under Absolute Maximum Ratings may cause permanent damage to the device. This is a stress rating only; functional operation of the device at these or any other conditions above those listed in the operational sections of this specification is not implied. Exposure to absolute maximum rating conditions for extended periods may affect device reliability.

ESD CAUTION



ESD (electrostatic discharge) sensitive device. Charged devices and circuit boards can discharge without detection. Although this product features patented or proprietary protection circuitry, damage may occur on devices subjected to high energy ESD. Therefore, proper ESD precautions should be taken to avoid performance degradation or loss of functionality.

PIN CONFIGURATION AND FUNCTION DESCRIPTIONS

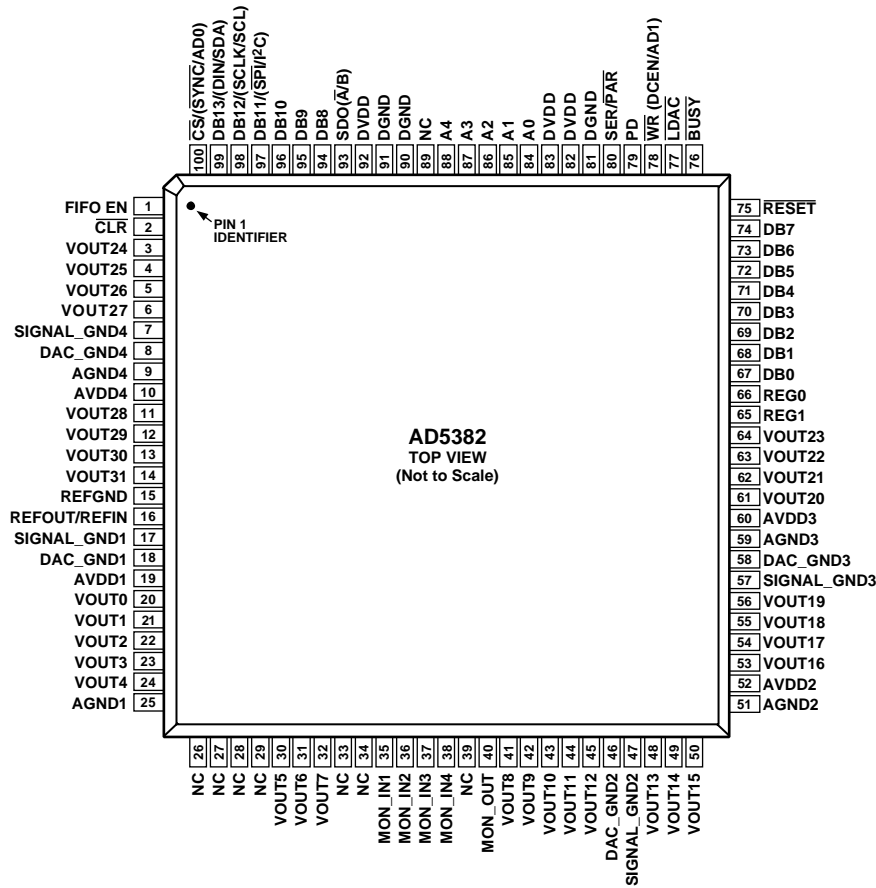

Figure 8. 100-Lead LQFP Pin Configuration

Table 9. Pin Function Descriptions

Mnemonic	Function
VOUTx	Buffered Analog Outputs for Channel x. Each analog output is driven by a rail-to-rail output amplifier operating at a gain of 2. Each output is capable of driving an output load of 5 kΩ to ground. Typical output impedance is 0.5 Ω.
SIGNAL_GND(1–4)	Analog Ground Reference Points for Each Group of Eight Output Channels. All SIGNAL_GND pins are tied together internally and should be connected to the AGND plane as close as possible to the AD5382.
DAC_GND(1–4)	Ground Reference point for the Internal 14-Bit DAC. Each group of eight channels contains a DAC_GND pin. These pins should be connected to the AGND plane.
AGND(1–4)	Analog Ground Reference Point. Each group of eight channels contains an AGND pin. All AGND pins should be connected externally to the AGND plane.
AVDD(1–4)	Analog Supply Pins. Each group of eight channels has a separate AVDD pin. These pins are internally shorted and should be decoupled with a 0.1 μF ceramic capacitor and a 10 μF tantalum capacitor. Operating range for the AD5382-5 is 4.5 V to 5.5 V; operating range for the AD5382-3 is 2.7 V to 3.6 V.
DGND	Ground for All Digital Circuitry.
DVDD	Logic Power Supply. Guaranteed operating range is 2.7 V to 5.5 V. It is recommended that these pins be decoupled with 0.1 μF ceramic and 10 μF tantalum capacitors to DGND.
REFGND	Ground Reference Point for the Internal Reference.
REFOUT/REFIN	Reference Output when the Internal Reference is Selected. The AD5382 contains a common REFOUT/REFIN pin. If the application requires an external reference, it can be applied to this pin, and the internal reference can be disabled via the control register. The default for this pin is a reference input.

Mnemonic	Function
MON_OUT	Monitor Output. When the monitor function is enabled, this pin acts as the output of a 36-to-1 channel multiplexer that can be programmed to multiplex one of Channels 0 to 31 or any of the monitor input pins (MON_IN1 to MON_IN4) to the MON_OUT pin. The MON_OUT pin's output impedance is typically 500 Ω and is intended to drive a high input impedance like that exhibited by SAR ADC inputs.
MON_INx	Monitor Input Pins. The AD5382 contains four monitor input pins that allow the user to connect input signals, within the maximum ratings of the device, to these pins for monitoring purposes. Any of the signals applied to the MON_IN pins, along with the 32 output channels, can be switched to the MON_OUT pin via software. For example, an external ADC can be used to monitor these signals.
SER/ $\overline{\text{PAR}}$	Interface Select Input. This pin allows the user to select whether the serial or parallel interface is used. If it is tied high, the serial interface mode is selected and Pin 97 ($\overline{\text{SPI/I}^2\text{C}}$) is used to determine if the interface mode is SPI or I ² C. Parallel interface mode is selected when SER/ $\overline{\text{PAR}}$ is low.
$\overline{\text{CS}}/(\overline{\text{SYNC}}/\text{AD0})$	In parallel interface mode, this pin acts as the chip select input (level sensitive, active low). When low, the AD5382 is selected. In serial interface mode, this is the frame synchronization input signal for the serial clocks before the addressed register is updated.
$\overline{\text{WR}}/(\text{DCEN}/\text{AD1})$	In I ² C mode, this pin acts as a hardware address pin used in conjunction with AD1 to determine the software address for the device on the I ² C bus. Multifunction Pin. In parallel interface mode, this pin acts as write enable. In serial interface mode, this pin acts as a daisy-chain enable in SPI mode and as a hardware address pin in I ² C mode. Parallel Interface Write Input (Edge Sensitive). The rising edge of $\overline{\text{WR}}$ is used in conjunction with $\overline{\text{CS}}$ low, and the address bus inputs to write to the selected device registers. Serial Interface. Daisy-chain select input (level sensitive, active high). When high, this signal is used in conjunction with SER/ $\overline{\text{PAR}}$ high to enable the SPI serial interface daisy-chain mode. I ² C Mode. This pin acts as a hardware address pin used in conjunction with AD0 to determine the software address for this device on the I ² C bus.
DB13–DB0	Parallel Data Bus. DB13 is the MSB and DB0 is the LSB of the input data-word on the AD5382.
A4–A0	Parallel Address Inputs. A4 to A0 are decoded to address one of the AD5382's 40 input channels. Used in conjunction with the REG1 and REG0 pins to determine the destination register for the input data.
REG1, REG0	In parallel interface mode, REG1 and REG0 are used in decoding the destination registers for the input data. REG1 and REG0 are decoded to address the input data register, offset register, or gain register for the selected channel and are also used to decide the special function registers.
SDO/ $(\overline{\text{A}}/\text{B})$	Serial Data Output in Serial Interface Mode. Three-stateable CMOS output. SDO can be used for daisy-chaining a number of devices together. Data is clocked out on SDO on the rising edge of SCLK, and is valid on the falling edge of SCLK. In parallel interface mode, this pin acts as the A or B data register select when writing data to the AD5382's data registers with toggle mode selected (see the Toggle Mode Function section). In toggle mode, the $\overline{\text{LDAC}}$ is used to switch the output between the data contained in the A and B data registers. All DAC channels contain two data registers. In normal mode, Data Register A is the default for data transfers.
$\overline{\text{BUSY}}$	Digital CMOS Output. $\overline{\text{BUSY}}$ goes low during internal calculations of the data (x2) loaded to the DAC data register. During this time, the user can continue writing new data to the x1, c, and m registers, but no further updates to the DAC registers and DAC outputs can take place. If $\overline{\text{LDAC}}$ is taken low while $\overline{\text{BUSY}}$ is low, this event is stored. $\overline{\text{BUSY}}$ also goes low during power-on reset, and when the $\overline{\text{RESET}}$ pin is low. During this time, the interface is disabled and any events on $\overline{\text{LDAC}}$ are ignored. A $\overline{\text{CLR}}$ operation also brings $\overline{\text{BUSY}}$ low.
$\overline{\text{LDAC}}$	Load DAC Logic Input (Active Low). If $\overline{\text{LDAC}}$ is taken low while $\overline{\text{BUSY}}$ is inactive (high), the contents of the input registers are transferred to the DAC registers, and the DAC outputs are updated. If $\overline{\text{LDAC}}$ is taken low while $\overline{\text{BUSY}}$ is active and internal calculations are taking place, the $\overline{\text{LDAC}}$ event is stored and the DAC registers are updated when $\overline{\text{BUSY}}$ goes inactive. However, any events on $\overline{\text{LDAC}}$ during power-on reset or on $\overline{\text{RESET}}$ are ignored.
$\overline{\text{CLR}}$	Asynchronous Clear Input. The CLR input is falling edge sensitive. When $\overline{\text{CLR}}$ is activated, all channels are updated with the data in the CLR code register. $\overline{\text{BUSY}}$ is low for 35 μs while all channels are being updated with the CLR code.
$\overline{\text{RESET}}$	Asynchronous Digital Reset Input (Falling Edge Sensitive). The function of this pin is equivalent to that of the power-on reset generator. When this pin is taken low, the state machine initiates a reset sequence to digitally reset the x1, m, c, and x2 registers to their default power-on values. This sequence takes 270 μs . The falling edge of $\overline{\text{RESET}}$ initiates the RESET process and $\overline{\text{BUSY}}$ goes low for the duration, returning high when RESET is complete. While $\overline{\text{BUSY}}$ is low, all interfaces are disabled and all $\overline{\text{LDAC}}$ pulses are ignored. When $\overline{\text{BUSY}}$ returns high, the part resumes normal operation, and the status of the $\overline{\text{RESET}}$ pin is ignored until the next falling edge is detected.

Mnemonic	Function
PD	Power Down (Level Sensitive, Active High). PD is used to place the device in to low power mode where the device consumes 2 μ A AIDD and 20 μ A DIDD. In power-down mode, all internal analog circuitry is placed in low power mode, and the analog output is configured as a high impedance output or provides a 100 k Ω load to ground, depending on how the power-down mode is configured. The serial interface remains active during power-down.
FIFO EN	FIFO Enable (Level Sensitive, Active High). When connected to DVDD, the internal FIFO is enabled, allowing the user to write to the device at full speed. FIFO is available only in parallel interface mode. The status of the FIFO EN pin is sampled on power-up, and also following a CLEAR or RESET, to determine if the FIFO is enabled. In either serial or I ² C interface modes, the FIFO EN pin should be tied low.
DB11/($\overline{\text{SPI}}$ /I ² C)	Multifunction Input Pin. In parallel interface mode, this pin acts as DB11 of the parallel input data-word. In serial interface mode, this pin acts as serial interface mode select. When serial interface mode is selected ($\overline{\text{SER/PAR}} = 1$) and this input is low, SPI mode is selected. In SPI mode, DB12 is the serial clock (SCLK) input and DB13 is the serial data (DIN) input. When serial interface mode is selected ($\overline{\text{SER/PAR}} = 1$) and this input is high, I ² C mode is selected. In this mode, DB12 is the serial clock (SCL) input and DB13 is the serial data (SDA) input.
DB12/(SCLK/SCL)	Multifunction Input Pin. In parallel interface mode, this pin acts as DB12 of the parallel input data-word. In serial interface mode, this pin acts as a serial clock input. Serial Interface Mode. In serial interface mode, data is clocked into the shift register on the falling edge of SCLK. This operates at clock speeds up to 50 MHz.
DB13/(DIN/SDA)	I ² C Mode. In I ² C mode, this pin performs the SCL function, clocking data into the device. The data transfer rate in I ² C mode is compatible with both 100 kHz and 400 kHz operating modes. Multifunction Data Input Pin. In parallel interface mode, this pin acts as DB13 of the parallel input data-word. Serial Interface Mode. In serial interface mode, this pin acts as the serial data input. Data must be valid on the falling edge of SCLK.
NC	I ² C Mode. In I ² C mode, this pin is the serial data pin (SDA) operating as an open-drain input/output. No Connect. The user is advised not to connect any signals to these pins.

TERMINOLOGY

Relative Accuracy

Relative accuracy or endpoint linearity is a measure of the maximum deviation from a straight line passing through the endpoints of the DAC transfer function. It is measured after adjusting for zero-scale error and full-scale error, and is expressed in LSB.

Differential Nonlinearity

Differential nonlinearity is the difference between the measured change and the ideal 1 LSB change between any two adjacent codes. A specified differential nonlinearity of 1 LSB maximum ensures monotonicity.

Zero-Scale Error

Zero-scale error is the error in the DAC output voltage when all 0s are loaded into the DAC register. Ideally, with all 0s loaded to the DAC and $m = \text{all } 1\text{s}$, $c = 2^n - 1$

$$VOUT_{(Zero-Scale)} = 0 V$$

Zero-scale error is a measurement of the difference between $VOUT$ (actual) and $VOUT$ (ideal), expressed in mV. It is mainly due to offsets in the output amplifier.

Offset Error

Offset error is a measurement of the difference between $VOUT$ (actual) and $VOUT$ (ideal) in the linear region of the transfer function, expressed in mV. Offset error is measured on the AD5382-5 with Code 32 loaded into the DAC register, and on the AD5382-3 with Code 64.

Gain Error

Gain error is specified in the linear region of the output range between $VOUT = 10 \text{ mV}$ and $VOUT = AVDD - 50 \text{ mV}$. It is the deviation in slope of the DAC transfer characteristic from the ideal and is expressed in %FSR with the DAC output unloaded.

DC Crosstalk

This is the dc change in the output level of one DAC at midscale in response to a full-scale code (all 0s to all 1s, and vice versa) and output change of all other DACs. It is expressed in LSB.

DC Output Impedance

This is the effective output source resistance. It is dominated by package lead resistance.

Output Voltage Settling Time

This is the amount of time it takes for the output of a DAC to settle to a specified level for a $\frac{1}{4}$ to $\frac{3}{4}$ full-scale input change, and is measured from the $BUSY$ rising edge.

Digital-to-Analog Glitch Energy

This is the amount of energy injected into the analog output at the major code transition. It is specified as the area of the glitch in nV-s. It is measured by toggling the DAC register data between 0x1FFF and 0x2000.

DAC-to-DAC Crosstalk

DAC-to-DAC crosstalk is the glitch impulse that appears at the output of one DAC due to both the digital change and to the subsequent analog output change at another DAC. The victim channel is loaded with midscale. DAC-to-DAC crosstalk is specified in nV-s.

Digital Crosstalk

The glitch impulse transferred to the output of one converter due to a change in the DAC register code of another converter is defined as the digital crosstalk and is specified in nV-s.

Digital Feedthrough

When the device is not selected, high frequency logic activity on the device's digital inputs can be capacitively coupled both across and through the device to show up as noise on the $VOUT$ pins. It can also be coupled along the supply and ground lines. This noise is digital feedthrough.

Output Noise Spectral Density

This is a measurement of internally generated random noise. Random noise is characterized as a spectral density (voltage per $\sqrt{\text{Hz}}$). It is measured by loading all DACs to midscale and measuring noise at the output. It is measured in nV/ $\sqrt{\text{Hz}}$ in a 1 Hz bandwidth at 10 kHz.

TYPICAL PERFORMANCE CHARACTERISTICS

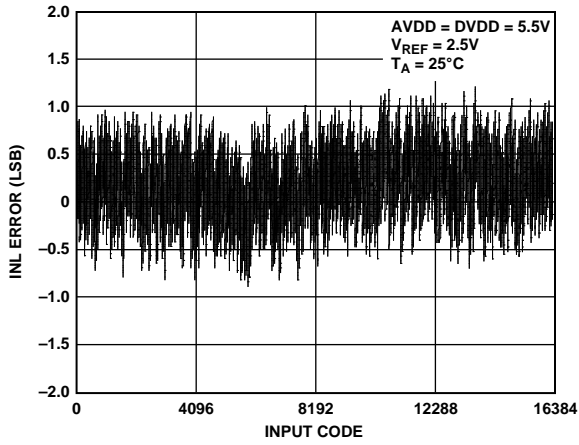

Figure 9. Typical AD5382-5 INL Plot

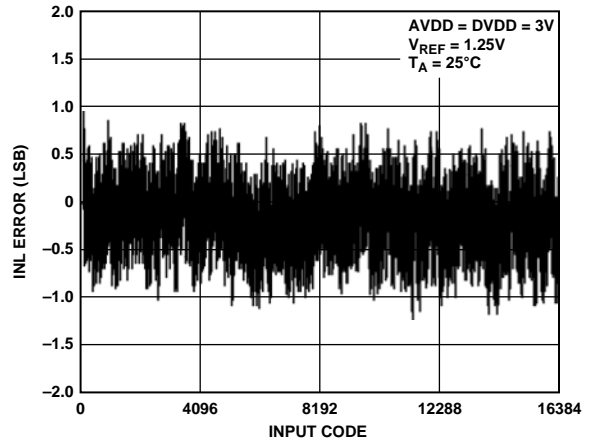

Figure 12. Typical AD5382-3 INL Plot

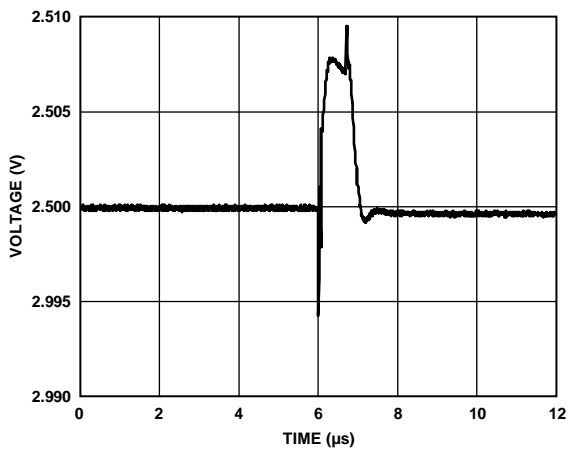

Figure 10. AD5382-5 Glitch Impulse

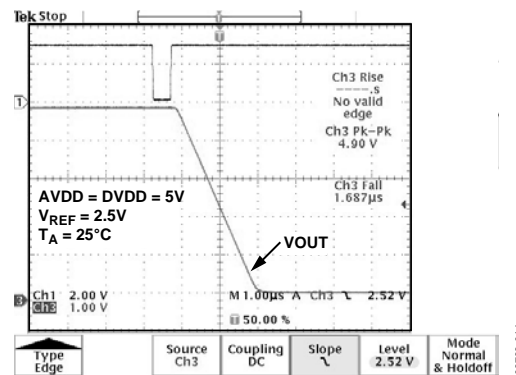

Figure 13. Slew Rate with Boost On

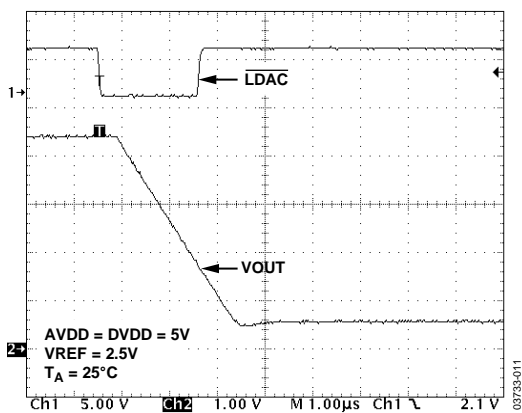

Figure 11. Slew Rate with Boost Off

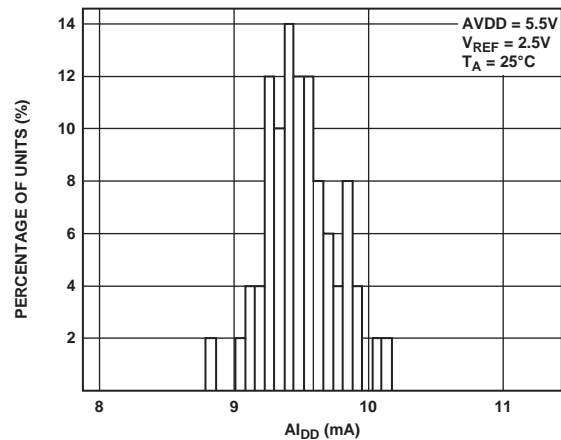

Figure 14. ALDD Histogram

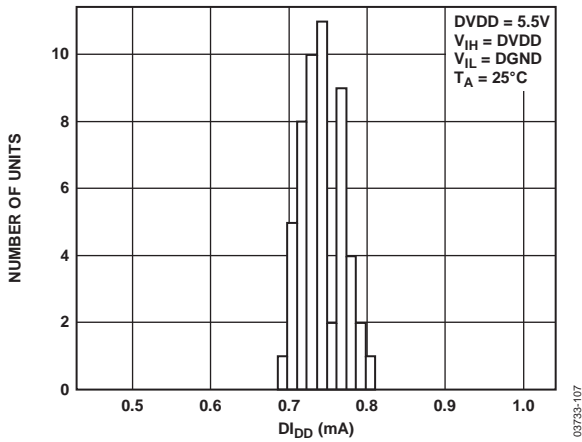

Figure 15. DI_{DD} Histogram

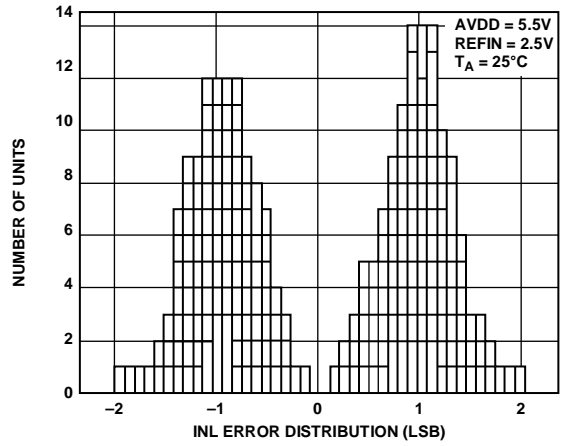

Figure 18. INL Error Distribution

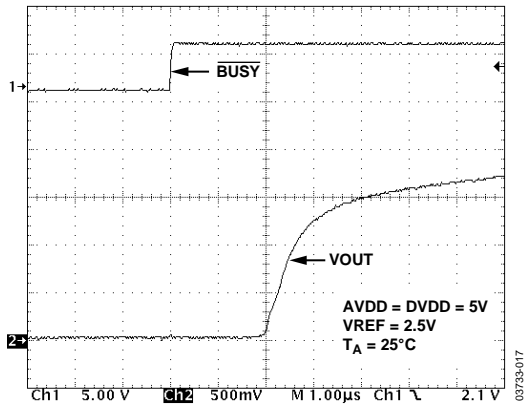

Figure 16. Exiting Soft Power-Down

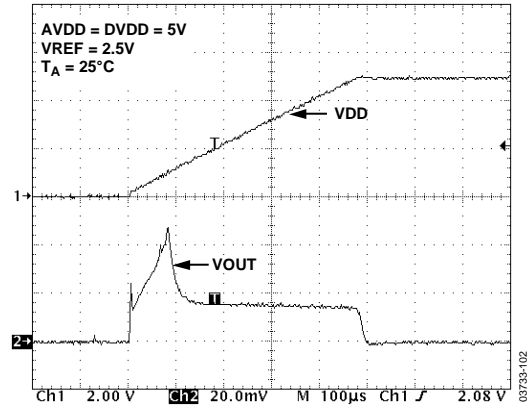

Figure 19. Exiting Hardware Power-Down

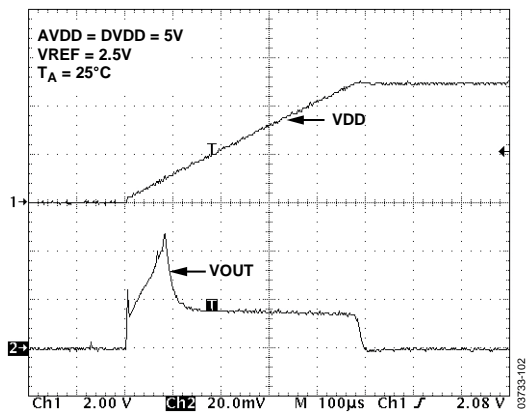

Figure 17. Power-Up Transient

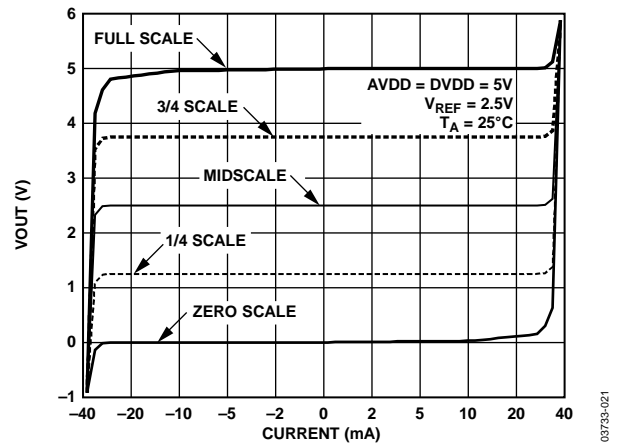

Figure 20. AD5382-5 Output Amplifier Source and Sink Capability

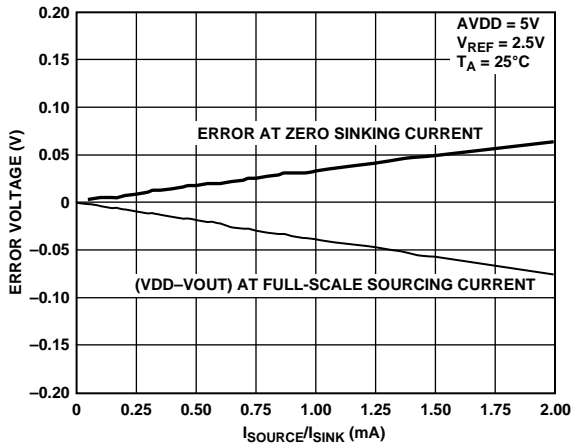

Figure 21. Headroom at Rails vs. Source/Sink Current

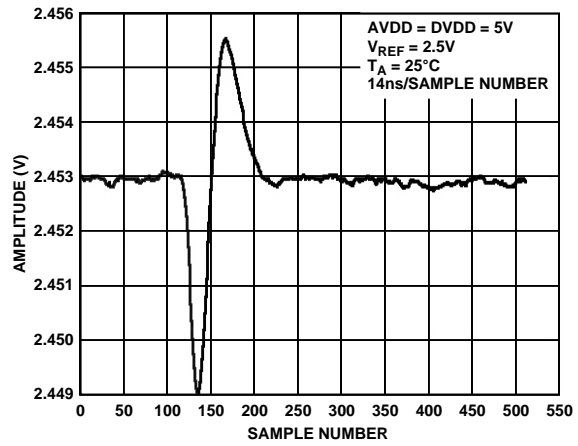

Figure 24. Adjacent Channel DAC-to-DAC Crosstalk

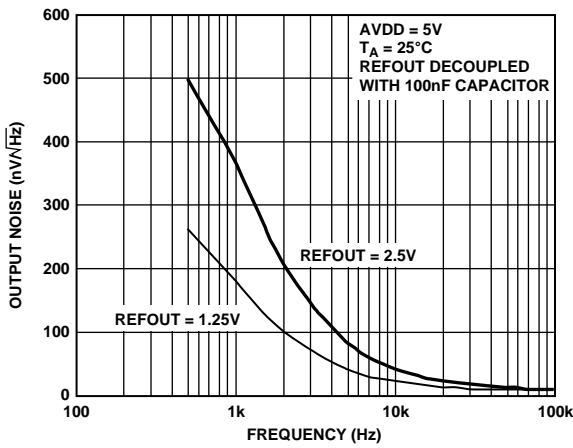

Figure 22 REFOUT Noise Spectral Density

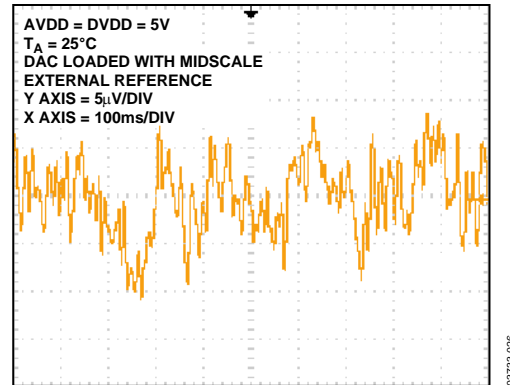

Figure 25. 0.1 Hz to 10 Hz Noise Plot

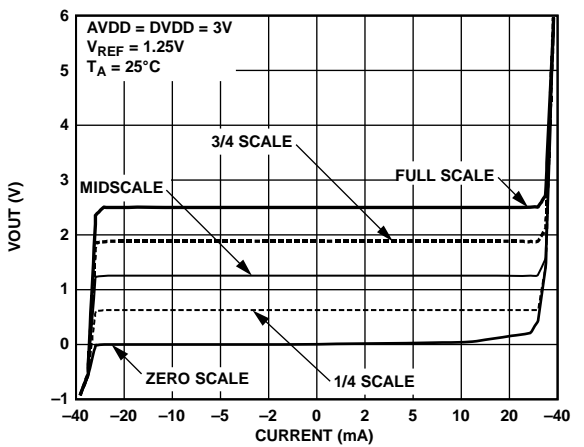

Figure 23. AD5382-3 Output Amplifier Source and Sink Capability

03773-022

03773-025

03733-023

03733-026

03733-024

FUNCTIONAL DESCRIPTION

DAC ARCHITECTURE—GENERAL

The AD5382 is a complete, single-supply, 32-channel voltage output DAC that offers 14-bit resolution. The part is available in a 100-lead LQFP package and features both a parallel and a serial interface. This product includes an internal, software-selectable, 1.25 V/2.5 V, 10 ppm/°C reference, which can be used to drive the buffered reference inputs; alternatively, an external reference can be used to drive these inputs. Internal/external reference selection is via the CR10 bit in the control register; CR12 selects the reference magnitude if the internal reference is selected. All channels have an on-chip output amplifier with rail-to-rail output capable of driving 5 kΩ in parallel with a 200 pF load.

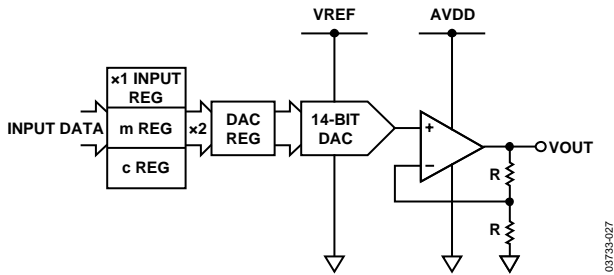

Figure 26. Single-Channel Architecture

The architecture of a single DAC channel consists of a 14-bit resistor-string DAC followed by an output buffer amplifier operating at a gain of 2. This resistor-string architecture guarantees DAC monotonicity. The 14-bit binary digital code loaded to the DAC register determines at what node on the string the voltage is tapped off before being fed to the output amplifier. Each channel on these devices contains independent offset and gain control registers that allow the user to digitally trim offset and gain. These registers give the user the ability to calibrate out errors in the complete signal chain, including the DAC, using the internal m and c registers, which hold the correction factors. All channels are double buffered, allowing synchronous updating of all channels using the $\overline{\text{LDAC}}$ pin. Figure 26 shows a block diagram of a single channel on the AD5382. The digital input transfer function for each DAC can be represented as

$$x2 = [(m + 2)/2^n \times x1] + (c - 2^{n-1})$$

where:

- x2 is the data-word loaded to the resistor string DAC.
- x1 is the 14-bit data-word written to the DAC input register.
- m is the gain coefficient (default is 0x3FFE on the AD5382). The gain coefficient is written to the 13 most significant bits (DB13 to DB1) and LSB (DB0) is a zero.
- n = DAC resolution (n = 14 for AD5382).
- c is the 14-bit offset coefficient (default is 0x2000).

The complete transfer function for these devices can be represented as

$$V_{OUT} = 2 \times V_{REF} \times x2/2^n$$

where:

x2 is the data-word loaded to the resistor string DAC, and V_{REF} is the internal reference voltage, or the reference voltage externally applied to the DAC REFOUT/REFIN pin. For specified performance, an external reference voltage of 2.5 V is recommended for the AD5380-5, and 1.25 V for the AD5380-3.

DATA DECODING

The AD5382 contains a 14-bit data bus, DB13–DB0. Depending on the value of REG1 and REG0 (see Table 10), this data is loaded into the addressed DAC input registers (x1), offset (c) registers, or gain (m) registers. The format data, offset (c), and gain (m) register contents are shown in Table 11 to Table 13.

Table 10. Register Selection

REG1	REG0	Register Selected
1	1	Input Data Register (x1)
1	0	Offset Register (c)
0	1	Gain Register (m)
0	0	Special Function Registers (SFRs)

Table 11. DAC Data Format (REG1 = 1, REG0 = 1)

DB13 to DB0				DAC Output (V)
11	1111	1111	1111	$2 V_{REF} \times (16383/16384)$
11	1111	1111	1110	$2 V_{REF} \times (16382/16384)$
10	0000	0000	0001	$2 V_{REF} \times (8193/16384)$
10	0000	0000	0000	$2 V_{REF} \times (8192/16384)$
01	1111	1111	1111	$2 V_{REF} \times (8191/16384)$
00	0000	0000	0001	$2 V_{REF} \times (1/16384)$
00	0000	0000	0000	0

Table 12. Offset Data Format (REG1 = 1, REG0 = 0)

DB13 to DB0				Offset (LSB)
11	1111	1111	1111	+8191
11	1111	1111	1110	+8190
10	0000	0000	0001	+1
10	0000	0000	0000	0
01	1111	1111	1111	-1
00	0000	0000	0001	-8191
00	0000	0000	0000	-8192

Table 13. Gain Data Format (REG1 = 0, REG0 = 1)

DB13 to DB0				Gain Factor
11	1111	1111	1110	1
10	1111	1111	1110	0.75
01	1111	1111	1110	0.5
00	1111	1111	1110	0.25
00	0000	0000	0000	0

ON-CHIP SPECIAL FUNCTION REGISTERS (SFR)

The AD5382 contains a number of special function registers (SFRs), as outlined in Table 14. SFRs are addressed with REG1 = REG0 = 0 and are decoded using Address Bits A4 to A0.

Table 14. SFR Register Functions (REG1 = 0, REG0 = 0)

R/W	A4	A3	A2	A1	A0	Function
X	0	0	0	0	0	NOP (No Operation)
0	0	0	0	0	1	Write Clear Code
0	0	0	0	1	0	Soft Clear
0	0	1	0	0	0	Soft Power-Down
0	0	1	0	0	1	Soft Power-Up
0	0	1	1	0	0	Control Register Write
1	0	1	1	0	0	Control Register Read
0	0	1	0	1	0	Monitor Channel
0	0	1	1	1	1	Soft Reset

SFR COMMANDS

NOP (No Operation)

REG1 = REG0 = 0, A4–A0 = 00000

Performs no operation but is useful in serial readback mode to clock out data on D_{OUT} for diagnostic purposes. BUSY pulses low during a NOP operation.

Write Clear Code

REG1 = REG0 = 0, A4–A0 = 00001

DB13–DB0 = Contain the clear code data

Bringing the $\overline{\text{CLR}}$ line low or exercising the soft clear function loads the contents of the DAC registers with the data contained in the user-configurable Clear register, and sets VOUT0 to VOUT31 accordingly. This can be very useful for setting up a specific output voltage in a clear condition. It is also beneficial for calibration purposes; the user can load full scale or zero scale to the clear code register and then issue a hardware or software clear to load this code to all DACs, removing the need for individual writes to each DAC. Default on power-up is all zeros.

Soft Clear

REG1 = REG0 = 0, A4–A0 = 00010

DB13–DB0 = Don't Care

Executing this instruction performs a software clear, which is functionally the same as that provided by the external $\overline{\text{CLR}}$ pin. The DAC outputs are loaded with the data in the Clear Code register (Table 14). It takes 35 μs to fully execute the Soft Clear and is indicated by the BUSY low time.

Soft Power-Down

REG1 = REG0 = 0, A4–A0 = 01000

DB13–DB0 = Don't Care

Executing this instruction performs a global power-down feature that puts all channels into a low power mode that reduces the analog supply current to 2 μA max and the digital current to 20 μA max. In power-down mode, the output amplifier can be configured as a high impedance output or provide a 100 k Ω load to ground. The contents of all internal registers are retained in power-down mode. No register can be written to while in power-down.

Soft Power-Up

REG1 = REG0 = 0, A4–A0 = 01001

DB13–DB0 = Don't Care

This instruction is used to power up the output amplifiers and the internal reference. The time to exit power-down is 8 μs . The hardware power-down and software functions are internally combined in a digital OR function.

Soft RESET

REG1 = REG0 = 0, A4–A0 = 01111

DB13–DB0 = Don't Care

This instruction is used to implement a software reset. All internal registers are reset to their default values, which correspond to m at full scale and c at zero. The contents of the DAC registers are cleared, setting all analog outputs to 0 V. The soft reset activation time is 135 μs max.

Table 15. Control Register Contents

MSB												LSB	
CR13	CR12	CR11	CR10	CR9	CR8	CR7	CR6	CR5	CR4	CR3	CR2	CR1	CR0

Control Register Write/Read

REG1 = REG0 = 0, A4–A0 = 01100, R/\overline{W} status determines if the operation is a write ($R/\overline{W} = 0$) or a read ($R/\overline{W} = 1$). DB13 to DB0 contain the control register data.

Control Register Contents

CR13: Power-Down Status. This bit is used to configure the output amplifier state in power-down.

CR13 = 1. Amplifier output is high impedance (default on power-up).

CR13 = 0. Amplifier output is 100 k Ω to ground.

CR12: REF Select. This bit selects the operating internal reference for the AD5382.

CR12 = 1: Internal reference is 2.5 V (AD5382-5 default), the recommended operating reference for AD5382-5.

CR12 = 0: Internal reference is 1.25 V (AD5382-3 default), the recommended operating reference for AD5382-3.

CR11: Current Boost Control. This bit is used to boost the current in the output amplifier, thereby altering its slew rate.

CR11 = 1: Boost Mode On. This maximizes the bias current in the output amplifier, optimizing its slew rate but increasing the power dissipation.

CR11 = 0: Boost Mode Off (default on power-up). This reduces the bias current in the output amplifier and reduces the overall power consumption.

CR10: Internal/External Reference. This bit determines if the DAC uses its internal reference or an externally applied reference.

CR10 = 1: Internal Reference Enabled. The reference output depends on data loaded to CR12.

CR10 = 0: External Reference Selected (default on power-up).

CR9: Channel Monitor Enable (see Channel Monitor Function)

CR9 = 1: Monitor Enabled. This enables the channel monitor function. After a write to the monitor channel in the SFR register, the selected channel output is routed to the MON_OUT pin.

CR9 = 0: Monitor Disabled (default on power-up). When the monitor is disabled, MON_OUT is three-stated.

CR8: Thermal Monitor Function. This function is used to monitor the AD5382's internal die temperature when enabled. The thermal monitor powers down the output amplifiers when the temperature exceeds 130°C. This function can be used to protect the device when power dissipation may be exceeded if a number of output channels are simultaneously short-circuited. A soft power-up re-enables the output amplifiers if the die temperature drops below 130°C.

CR8 = 1: Thermal Monitor Enabled.

CR8 = 0: Thermal Monitor Disabled (default on power-up).

CR7 and CR6: Don't Care.

CR5 to CR2: Toggle Function Enable. This function allows the user to toggle the output between two codes loaded to the A and B register for each DAC. Control Register Bits CR5 to CR2 are used to enable individual groups of eight channels for operation in toggle mode. A Logic 1 written to any bit enables a group of channels; a Logic 0 disables a group. \overline{LDAC} is used to toggle between the two registers. Table 16 shows the decoding for toggle contains Channels 24 to 31, CR5 = 1 enables these channels.

Table 16.

CR Bit	Group	Channels
CR5	3	24–31
CR4	2	16–23
CR3	1	8–15
CR2	0	0–7

CR1 and CR0: Don't Care.

Channel Monitor Function

REG1 = REG0 = 0, A4–A0 = 01010

DB13–DB8 = Contain data to address the monitored channel

A channel monitor function is provided on the AD5382. This feature, which consists of a multiplexer addressed via the interface, allows any channel output or the signals connected to the MON_IN inputs to be routed to the MON_OUT pin for monitoring using an external ADC. The channel monitor function must be enabled in the control register before any channels are routed to MON_OUT. On the AD5382, DB13 to DB8 contain the channel address for the monitored channel. Selecting channel address 63 three-states MON_OUT.

Table 17. AD5382 Channel Monitor Decoding

REG1	REG0	A4	A3	A2	A1	A0	DB13	DB12	DB11	DB10	DB9	DB8	DB7-DB0	MON_OUT
0	0	0	1	0	1	0	0	0	0	0	0	0	X	VOUT0
0	0	0	1	0	1	0	0	0	0	0	0	1	X	VOUT1
0	0	0	1	0	1	0	0	0	0	0	1	0	X	VOUT2
0	0	0	1	0	1	0	0	0	0	0	1	1	X	VOUT3
0	0	0	1	0	1	0	0	0	0	1	0	0	X	VOUT4
0	0	0	1	0	1	0	0	0	0	1	0	1	X	VOUT5
0	0	0	1	0	1	0	0	0	0	1	1	0	X	VOUT6
0	0	0	1	0	1	0	0	0	0	1	1	1	X	VOUT7
0	0	0	1	0	1	0	0	0	1	0	0	0	X	VOUT8
0	0	0	1	0	1	0	0	0	1	0	0	1	X	VOUT9
0	0	0	1	0	1	0	0	0	1	0	1	0	X	VOUT10
0	0	0	1	0	1	0	0	0	1	0	1	1	X	VOUT11
0	0	0	1	0	1	0	0	0	1	1	0	0	X	VOUT12
0	0	0	1	0	1	0	0	0	1	1	0	1	X	VOUT13
0	0	0	1	0	1	0	0	0	1	1	1	0	X	VOUT14
0	0	0	1	0	1	0	0	0	1	1	1	1	X	VOUT15
0	0	0	1	0	1	0	0	1	0	0	0	0	X	VOUT16
0	0	0	1	0	1	0	0	1	0	0	0	1	X	VOUT17
0	0	0	1	0	1	0	0	1	0	0	1	0	X	VOUT18
0	0	0	1	0	1	0	0	1	0	0	1	1	X	VOUT19
0	0	0	1	0	1	0	0	1	0	1	0	0	X	VOUT20
0	0	0	1	0	1	0	0	1	0	1	0	1	X	VOUT21
0	0	0	1	0	1	0	0	1	0	1	1	0	X	VOUT22
0	0	0	1	0	1	0	0	1	0	1	1	1	X	VOUT23
0	0	0	1	0	1	0	0	1	1	0	0	0	X	VOUT24
0	0	0	1	0	1	0	0	1	1	0	0	1	X	VOUT25
0	0	0	1	0	1	0	0	1	1	0	1	0	X	VOUT26
0	0	0	1	0	1	0	0	1	1	0	1	1	X	VOUT27
0	0	0	1	0	1	0	0	1	1	1	0	0	X	VOUT28
0	0	0	1	0	1	0	0	1	1	1	0	1	X	VOUT29
0	0	0	1	0	1	0	0	1	1	1	1	0	X	VOUT30
0	0	0	1	0	1	0	0	1	1	1	1	1	X	VOUT31
0	0	0	1	0	1	0	1	0	0	0	0	0	X	Undefined
0	0	0	1	0	1	0	1	0	0	0	0	1	X	Undefined
0	0	0	1	0	1	0	1	0	0	0	1	0	X	MON_IN1
0	0	0	1	0	1	0	1	0	0	1	1	1	X	MON_IN2
0	0	0	1	0	1	0	1	0	1	0	0	0	X	MON_IN3
0	0	0	1	0	1	0	1	0	1	0	1	1	X	MON_IN4
•	•	•	•	•	•	•	•	•	•	•	•	•	•	•
•	•	•	•	•	•	•	•	•	•	•	•	•	•	•
0	0	0	1	0	1	0	1	1	1	1	1	0	X	Undefined
0	0	0	1	0	1	0	1	1	1	1	1	1	X	Three-State

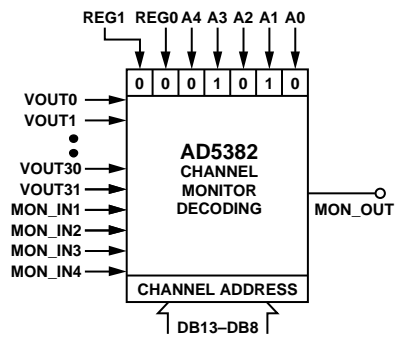

Figure 27. Channel Monitor Decoding

HARDWARE FUNCTIONS

RESET FUNCTION

Bringing the $\overline{\text{RESET}}$ line low resets the contents of all internal registers to their power-on reset state. Reset is a negative edge-sensitive input. The default corresponds to m at full scale and to c at zero scale. The contents of the DAC registers are cleared, setting VOUT0 to VOUT31 to 0 V. This sequence takes 270 μs max. The falling edge of $\overline{\text{RESET}}$ initiates the reset process; $\overline{\text{BUSY}}$ goes low for the duration, returning high when $\overline{\text{RESET}}$ is complete. While $\overline{\text{BUSY}}$ is low, all interfaces are disabled and all LDAC pulses are ignored. When $\overline{\text{BUSY}}$ returns high, the part resumes normal operation and the status of the $\overline{\text{RESET}}$ pin is ignored until the next falling edge is detected.

ASYNCHRONOUS CLEAR FUNCTION

Bringing the $\overline{\text{CLR}}$ line low clears the contents of the DAC registers to the data contained in the user-configurable CLR register and sets VOUT0 to VOUT31 accordingly. This function can be used in system calibration to load zero scale and full scale to all channels. The execution time for a CLR is 35 μs .

BUSY AND LDAC FUNCTIONS

$\overline{\text{BUSY}}$ is a digital CMOS output that indicates the status of the AD5382. The value of x_2 , the internal data loaded to the DAC data register, is calculated each time the user writes new data to the corresponding x_1 , c , or m register. During the calculation of x_2 , the $\overline{\text{BUSY}}$ output goes low. While $\overline{\text{BUSY}}$ is low, the user can continue writing new data to the x_1 , m , or c register, but no DAC output updates can take place. The DAC outputs are updated by taking the $\overline{\text{LDAC}}$ input low. If $\overline{\text{LDAC}}$ goes low while $\overline{\text{BUSY}}$ is active, the LDAC event is stored and the DAC outputs update immediately after $\overline{\text{BUSY}}$ goes high. The user may hold the $\overline{\text{LDAC}}$ input permanently low, in which case the DAC outputs update immediately after $\overline{\text{BUSY}}$ goes high. $\overline{\text{BUSY}}$ also goes low during power-on reset and when a falling edge is detected on the $\overline{\text{RESET}}$ pin. During this time, all interfaces are disabled and any events on $\overline{\text{LDAC}}$ are ignored.

The AD5382 contains an extra feature whereby a DAC register is not updated unless its x_2 register has been written to since the last time $\overline{\text{LDAC}}$ was brought low. Normally, when $\overline{\text{LDAC}}$ is brought low, the DAC registers are filled with the contents of the x_2 registers. However, the AD5382 updates the DAC register only if the x_2 data changes, thereby removing unnecessary digital crosstalk.

FIFO OPERATION IN PARALLEL MODE

The AD5382 contains a FIFO to optimize operation when operating in parallel interface mode. The FIFO EN pin (level sensitive, active high) is used to enable the internal FIFO. When connected to DVDD, the internal FIFO is enabled, allowing the user to write to the device at full speed. FIFO is only available in parallel interface mode. The status of the FIFO EN pin is sampled on power-up, and after a CLEAR or RESET, to determine if the FIFO is enabled. In either serial or I²C interface mode, FIFO EN should be tied low. Up to 128 successive instructions can be written to the FIFO at maximum speed in parallel mode. When the FIFO is full, further writes to the device are ignored. Figure 28 shows a comparison between FIFO mode and non-FIFO mode in terms of channel update time. Figure 28 also shows digital loading time.

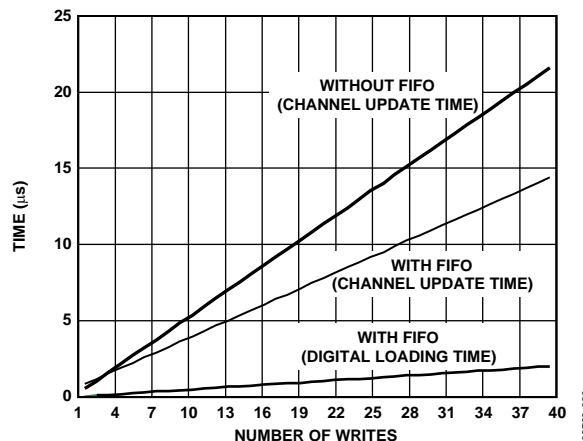

Figure 28. Channel Update Rate (FIFO vs. Non-FIFO)

POWER-ON RESET

The AD5382 contains a power-on reset generator and a state machine. The power-on reset resets all registers to a predefined state and configures the analog outputs as high impedance. The $\overline{\text{BUSY}}$ pin goes low during the power-on reset sequencing, preventing data writes to the device.

POWER-DOWN

The AD5382 contains a global power-down feature, which puts all channels into a low power mode and reduces the analog power consumption to 2 μA max and digital power consumption to 20 μA max. In power-down mode, the output amplifier can be configured as a high impedance output or provide a 100 k Ω load to ground. The contents of all internal registers are retained in power-down mode. When exiting power-down, the settling time of the amplifier elapses before the outputs settle to their correct values.

AD5382 INTERFACES

The AD5382 contains both parallel and serial interfaces. Furthermore, the serial interface can be programmed to be either SPI-, DSP-, MICROWIRE-, or I²C-compatible. The SER/ $\overline{\text{PAR}}$ pin selects $\overline{\text{parallel}}$ and serial interface modes. In serial mode, the SPI/I²C pin is used to select DSP, SPI, MICROWIRE, or I²C interface mode.

The device uses an internal FIFO memory to allow high speed successive writes in parallel interface mode. The user can continue writing new data to the device while write instructions are being executed. The $\overline{\text{BUSY}}$ signal indicates the current status of the device, going low while instructions in the FIFO are being executed. In parallel mode, up to 128 successive instructions can be written to the FIFO at maximum speed. When the FIFO is full, further writes to the device are ignored.

To minimize both the power consumption of the device and the on-chip digital noise, the active interface powers up fully when only the device is being written to, that is, on the falling edge of $\overline{\text{WR}}$ or the falling edge of $\overline{\text{SYNC}}$.

DSP-, SPI-, MICROWIRE-COMPATIBLE SERIAL INTERFACES

The serial interface can be operated with a minimum of three wires in standalone mode or four wires in daisy-chain mode. Daisy chaining allows many devices to be cascaded together to increase system channel count. The SER/ $\overline{\text{PAR}}$ pin must be tied high and the SPI/I²C pin (Pin 97) should be tied low to enable the DSP-, SPI-, MICROWIRE-compatible serial interface. In serial interface mode, the user does not need to drive the parallel input data pins. The serial interface's control pins are as follows:

- $\overline{\text{SYNC}}$, $\overline{\text{DIN}}$, $\overline{\text{SCLK}}$ —Standard 3-wire interface pins.
- $\overline{\text{DCEN}}$ —Selects standalone mode or daisy-chain mode.
- $\overline{\text{SDO}}$ —Data out pin for daisy-chain mode.

Figure 3 and Figure 5 show timing diagrams for a serial write to the AD5382 in standalone and daisy-chain modes. The 24-bit data-word format for the serial interface is shown in Table 18.

$\overline{\text{A/B}}$. When toggle mode is enabled, this pin selects whether the data write is to the A or B register. With toggle disabled, this bit should be set to 0 to select the A data register.

$\overline{\text{R/W}}$ is the read or write control bit.

$\overline{\text{A4-A0}}$ are used to address the input channels.

$\overline{\text{REG1}}$ and $\overline{\text{REG0}}$ select the register to which data is written, as shown in Table 10.

$\overline{\text{DB13-DB0}}$ contain the input data-word.

X is a don't care condition.

Standalone Mode

By connecting the $\overline{\text{DCEN}}$ (daisy-chain enable) pin low, standalone mode is enabled. The serial interface works with both a continuous and a noncontinuous serial clock. The first falling edge of $\overline{\text{SYNC}}$ starts the write cycle and resets a counter that counts the number of serial clocks to ensure that the correct number of bits are shifted into the serial shift register. Any further edges on $\overline{\text{SYNC}}$ except for a falling edge are ignored until 24 bits are clocked in. Once 24 bits are shifted in, the $\overline{\text{SCLK}}$ is ignored. For another serial transfer to take place, the counter must be reset by the falling edge of $\overline{\text{SYNC}}$.

Table 18. 32-Channel, 14-Bit DAC Serial Input Register Configuration

MSB														LSB									
$\overline{\text{A/B}}$	$\overline{\text{R/W}}$	0	A4	A3	A2	A1	A0	REG1	REG0	DB13	DB12	DB11	DB10	DB9	DB8	DB7	DB6	DB5	DB4	DB3	DB2	DB1	DB0

Daisy-Chain Mode

For systems that contain several devices, the SDO pin can be used to daisy-chain several devices together. This daisy-chain mode can be useful in system diagnostics and in reducing the number of serial interface lines.

By connecting the DCEN (daisy-chain enable) pin high, daisy-chain mode is enabled. The first falling edge of SYNC starts the write cycle. The SCLK is continuously applied to the input shift register when SYNC is low. If more than 24 clock pulses are applied, the data ripples out of the shift register and appears on the SDO line. This data is clocked out on the rising edge of SCLK and is valid on the falling edge. By connecting the SDO of the first device to the DIN input on the next device in the chain, a multidevice interface is constructed. Twenty-four clock pulses are required for each device in the system. Therefore, the total number of clock cycles must equal 24N, where N is the total number of AD538x devices in the chain.

When the serial transfer to all devices is complete, SYNC is taken high. This latches the input data in each device in the daisy-chain and prevents further data from being clocked into the input shift register.

If the SYNC is taken high before 24 clocks are clocked into the part, this is considered a bad frame and the data is discarded.

The serial clock can be either a continuous or a gated clock. A continuous SCLK source can be used only if SYNC can be held low for the correct number of clock cycles. In gated clock mode, a burst clock containing the exact number of clock cycles must be used, and SYNC must be taken high after the final clock to latch the data.

Readback Mode

Readback mode is invoked by setting the R/W bit = 1 in the serial input register write. With R/W = 1, Bits A4 to A0, in association with Bits REG1 and REG0, select the register to be read. The remaining data bits in the write sequence are don't cares. During the next SPI write, the data appearing on the SDO output contains the data from the previously addressed register. For a read of a single register, the NOP command can be used in clocking out the data from the selected register on SDO.

Figure 29 shows the readback sequence. For example, to read back the m register of Channel 0 on the AD5382, the following sequence should be implemented. First, write 0x404XXX to the AD5382 input register. This configures the AD5382 for read mode with the m register of Channel 0 selected. Data Bits DB13 to DB0 are don't cares. Follow this with a second write, a NOP condition, 0x000000. During this write, the data from the m register is clocked out on the DOUT line, that is, data clocked out contains the data from the m register in Bits DB13 to DB0, and the top 10 bits contain the address information as previously written. In readback mode, the SYNC signal must frame the data. Data is clocked out on the rising edge of SCLK and is valid on the falling edge of the SCLK signal. If the SCLK idles high between the write and read operations of a readback operation, the first bit of data is clocked out on the falling edge of SYNC.

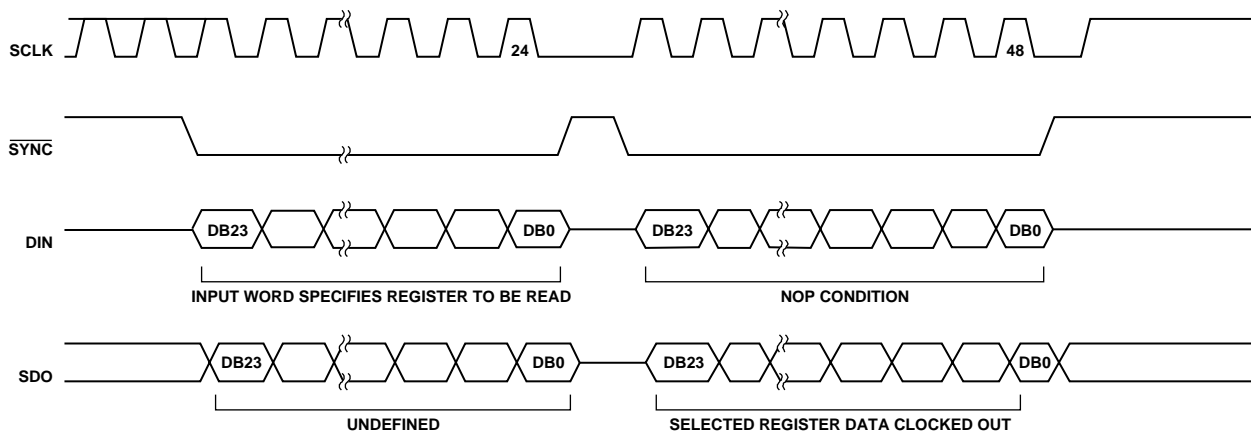

Figure 29. Serial Readback Operation

03733-030

I²C SERIAL INTERFACE

The AD5382 features an I²C-compatible 2-wire interface consisting of a serial data line (SDA) and a serial clock line (SCL). SDA and SCL facilitate communication between the AD5382 and the master at rates up to 400 kHz. Figure 6 shows the 2-wire interface timing diagrams that incorporate three different modes of operation. In selecting the I²C operating mode, first configure serial operating mode ($\overline{\text{SER/PAR}} = 1$) and then select I²C mode by configuring the $\overline{\text{SPI/I}^2\text{C}}$ pin to a Logic 1. The device is connected to the I²C bus as a slave device (no clock is generated by the AD5382). The AD5382 has a 7-bit slave address, 1010 1AD1AD0. The 5 MSB are hard-coded and the 2 LSB are determined by the state of the AD1 and AD0 pins. The facility to hardware configure AD1 and AD0 allows four of these devices to be configured on the bus.

I²C Data Transfer

One data bit is transferred during each SCL clock cycle. The data on SDA must remain stable during the high period of the SCL clock pulse. Changes in SDA while SCL is high are control signals that configure start and stop conditions. Both SDA and SCL are pulled high by the external pull-up resistors when the I²C bus is not busy.

Start and Stop Conditions

A master device initiates communication by issuing a start condition. A start condition is a high-to-low transition on SDA with SCL high. A stop condition is a low-to-high transition on SDA while SCL is high. A start condition from the master signals the beginning of a transmission to the AD5382. The stop condition frees the bus. If a repeated start condition (Sr) is generated instead of a stop condition, the bus remains active.

Repeated Start Conditions

A repeated start (Sr) condition can indicate a change of data direction on the bus. Sr may be used when the bus master is writing to several I²C devices and wants to maintain control of the bus.

Acknowledge Bit (ACK)

The acknowledge bit (ACK) is the ninth bit attached to any 8-bit data-word. ACK is always generated by the receiving device. The AD5382 devices generate an ACK when receiving an address or data by pulling SDA low during the ninth clock period. Monitoring ACK allows detection of unsuccessful data transfers. An unsuccessful data transfer occurs if a receiving device is busy or if a system fault has occurred. In the event of an unsuccessful data transfer, the bus master should reattempt communication.

AD5382 Slave Addresses

A bus master initiates communication with a slave device by issuing a start condition followed by the 7-bit slave address. When idle, the AD5382 waits for a start condition followed by its slave address. The LSB of the address word is the Read/ Write (R/W) bit. The AD5382 is a receive-only device; when communicating with the AD5382, $\overline{\text{R/W}} = 0$. After receiving the proper address 1010 1AD1AD0, the AD5382 issues an ACK by pulling SDA low for one clock cycle.

The AD5382 has four different user-programmable addresses determined by the AD1 and AD0 bits.

Write Operation

Data can be written to the AD5382 DAC in three specific modes.

4-Byte Mode

When writing to the AD5382 DACs, the user must begin with an address byte ($\overline{\text{R/W}} = 0$) after which the DAC acknowledges that it is prepared to receive data by pulling SDA low. The address byte is followed by the pointer byte; this addresses the specific channel in the DAC to be addressed and is also acknowledged by the DAC. Two bytes of data are then written to the DAC, as shown in Figure 30. A stop condition follows. This allows the user to update a single channel within the AD5382 at anytime and requires four bytes of data to be transferred from the master.

3-Byte Mode

In 3-byte mode, the user can update more than one channel in a write sequence without having to write the device address byte each time. The device address byte is required only once; subsequent channel updates require the pointer byte and the data bytes. In 3-byte mode, the user begins with an address byte ($\overline{\text{R/W}} = 0$), after which the DAC acknowledges that it is prepared to receive data by pulling SDA low. The address byte is followed by the pointer byte. This addresses the specific channel in the DAC to be addressed and is also acknowledged by the DAC. This is then followed by the two data bytes. REG1 and REG0 determine the register to be updated.

If a stop condition does not follow the data bytes, another channel can be updated by sending a new pointer byte followed by the data bytes. This mode requires only three bytes to be sent to update any channel once the device is initially addressed, and reduces the software overhead in updating the AD5382 channels. A stop condition at any time exits this mode. Figure 31 shows a typical configuration.

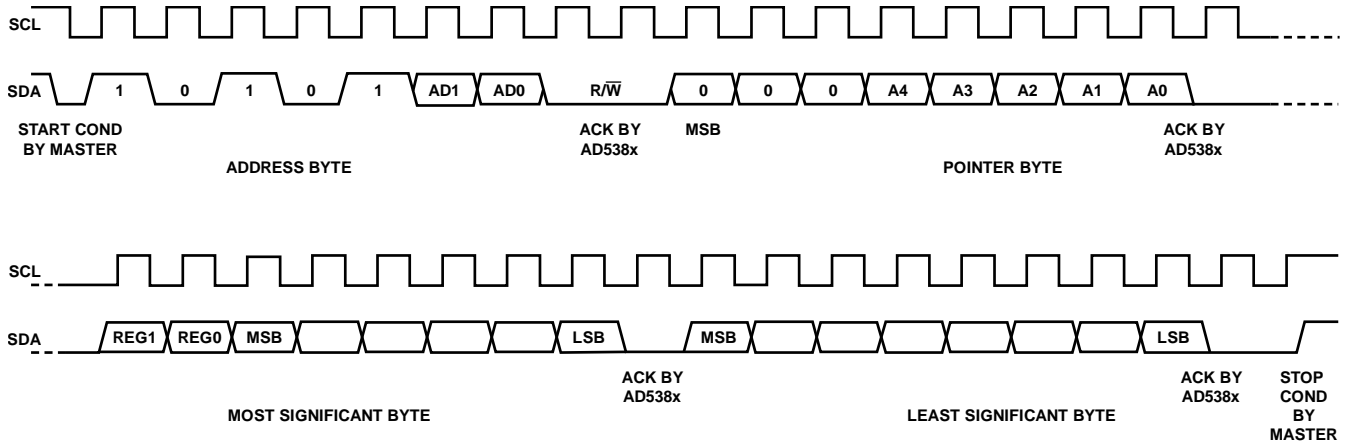

Figure 30. 4-Byte AD5382, I²C Write Operation

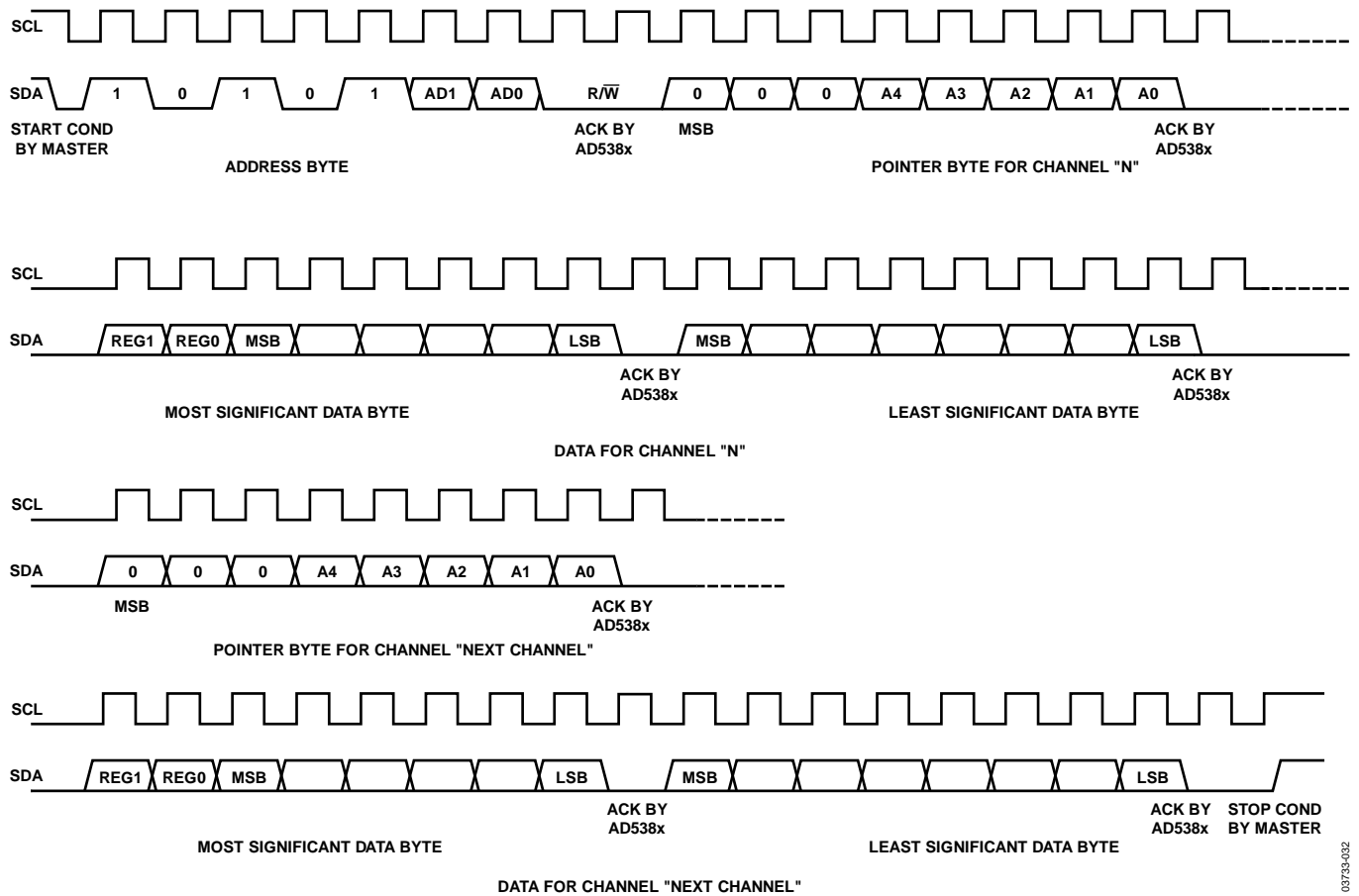

Figure 31. 3-Byte AD5382, I²C Write Operation

2-Byte Mode

Following initialization of 2-byte mode, the user can update channels sequentially. The device address byte is required only once, and the pointer address pointer is configured for auto-increment or burst mode.

The user must begin with an address byte ($R/\overline{W} = 0$), after which the DAC acknowledges that it is prepared to receive data by pulling SDA low. The address byte is followed by a specific pointer byte (0xFF) that initiates the burst mode of operation. The address pointer initializes to Channel 0, the data following the pointer is loaded to Channel 0, and the address pointer automatically increments to the next address.

The REG0 and REG1 bits in the data byte determine which register is updated. In this mode, following the initialization, only the two data bytes are required to update a channel. The channel address automatically increments from Address 0 to Channel 31 and then returns to the normal 3-byte mode of operation. This mode allows transmission of data to all channels in one block and reduces the software overhead in configuring all channels. A stop condition at any time exits this mode. Toggle mode is not supported in 2-byte mode. Figure 32 shows a typical configuration.

PARALLEL INTERFACE

The $\overline{SER}/\overline{PAR}$ pin must be tied low to enable the parallel interface and disable the serial interfaces. Figure 7 shows the timing diagram for a parallel write. The parallel interface is controlled by the following pins.

\overline{CS} Pin

Active low device select pin.

\overline{WR} Pin

On the rising edge of \overline{WR} , with \overline{CS} low, the addresses on Pins A4 to A0 are latched; data present on the data bus is loaded into the selected input registers.

REG0, REG1 Pins

The REG0 and REG1 pins determine the destination register of the data being written to the AD5382. See Table 10.

Pins A4 to A0

Each of the 40 DAC channels can be addressed individually.

Pins DB13 to DB0

The AD5382 accepts a straight 14-bit parallel word on DB13 to DB0, where DB13 is the MSB and DB0 is the LSB.

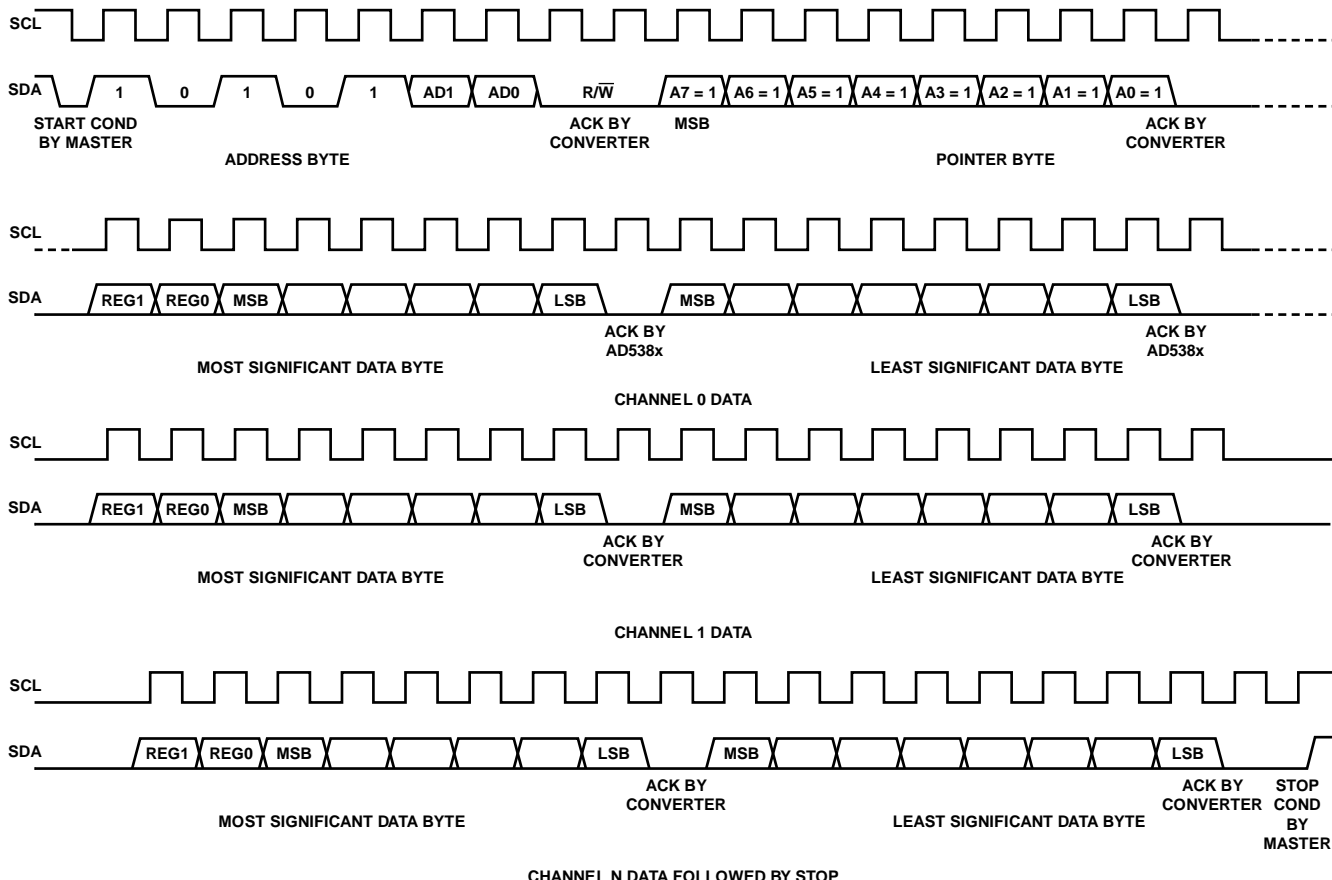

Figure 32. 2-Byte, I²C Write Operation

03733-033

MICROPROCESSOR INTERFACING

Parallel Interface

The AD5382 can be interfaced to a variety of 16-bit microcontrollers or DSP processors. Figure 34 shows the AD5382 family interfaced to a generic 16-bit microcontroller/DSP processor. The lower address lines from the processor are connected to A0–A4 on the AD5382. The upper address lines are decoded to provide a CS, LDAC signal for the AD5382. The fast interface timing of the AD5382 allows direct interface to a wide variety of microcontrollers and DSPs, as shown in Figure 34.

AD5382 to MC68HC11

The serial peripheral interface (SPI) on the MC68HC11 is configured for master mode (MSTR = 1), Clock Polarity bit (CPOL) = 0, and the Clock Phase bit (CPHA) = 1. The SPI is configured by writing to the SPI control register (SPCR)—see the 68HC11 User Manual. SCK of the 68HC11 drives the SCLK of the AD5382, the MOSI output drives the serial data line (DIN) of the AD5382, and the MISO input is driven from DOUT. The SYNC signal is derived from a port line (PC7).

When data is being transmitted to the AD5382, the SYNC line is taken low (PC7). Data appearing on the MOSI output is valid on the falling edge of SCK. Serial data from the 68HC11 is transmitted in 8-bit bytes with only eight falling clock edges occurring in the transmit cycle.

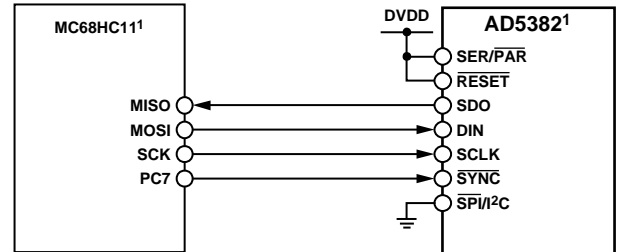

¹ADDITIONAL PINS OMITTED FOR CLARITY.

Figure 33. AD5382-to-MC68HC11 Interface

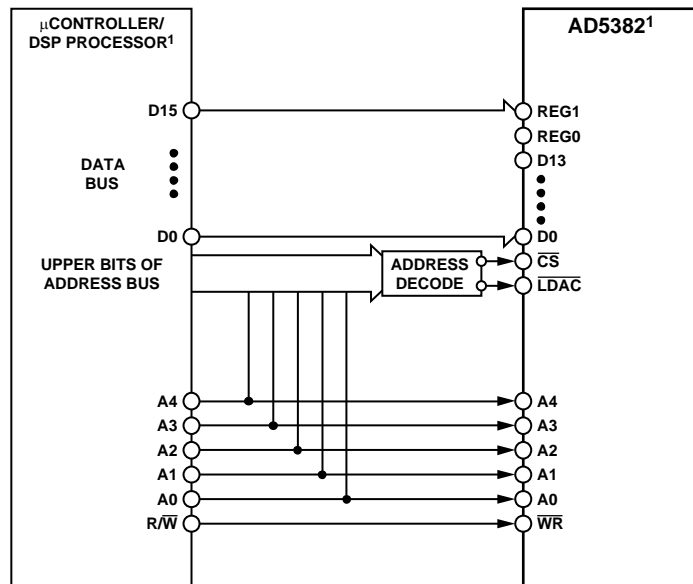

¹ADDITIONAL PINS OMITTED FOR CLARITY.

Figure 34. AD5382-to-Parallel Interface

AD5382 to PIC16C6x/7x

The PIC16C6x/7x synchronous serial port (SSP) is configured as an SPI master with the Clock Polarity bit = 0. This is done by writing to the synchronous serial port control register (SSPCON). See the PIC16/17 Microcontroller User Manual. In this example I/O, Port RA1 is being used to pulse SYNC and enable the serial port of the AD5382. This microcontroller transfers only eight bits of data during each serial transfer operation; therefore, three consecutive read/write operations may be needed depending on the mode. Figure 35 shows the connection diagram.

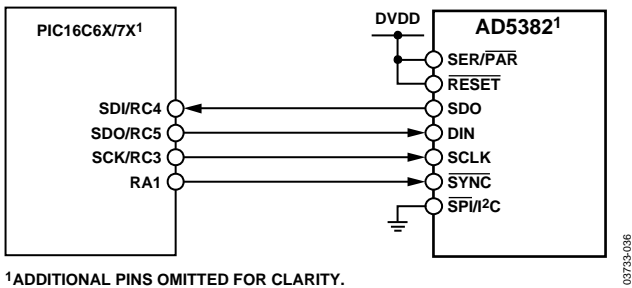

¹ADDITIONAL PINS OMITTED FOR CLARITY.

Figure 35. AD5382-to-PIC16C6x/7x Interface

AD5382 to 8051

The AD5382 requires a clock synchronized to the serial data. The 8051 serial interface must therefore be operated in Mode 0. In this mode, serial data enters and exits through RxD, and a shift clock is output on TxD. Figure 36 shows how the 8051 is connected to the AD5382. Because the AD5382 shifts data out on the rising edge of the shift clock and latches data in on the falling edge, the shift clock must be inverted. The AD5382 requires its data to be MSB first. Since the 8051 outputs the LSB first, the transmit routine must take this into account.

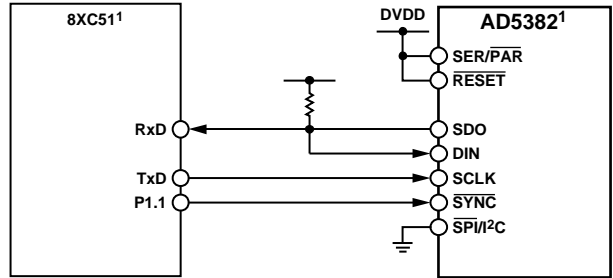

¹ADDITIONAL PINS OMITTED FOR CLARITY.

Figure 36. AD5382-to-8051 Interface

AD5382 to ADSP-2101/ADSP-2103

Figure 37 shows a serial interface between the AD5382 and the ADSP-2101/ADSP-2103. The ADSP-2101/ADSP-2103 should be set up to operate in SPORT transmit alternate framing mode. The ADSP-2101/ADSP-2103 SPORT is programmed through the SPORT control register and should be configured as follows: internal clock operation, active low framing, and 16-bit word length. Transmission is initiated by writing a word to the Tx register after the SPORT has been enabled.

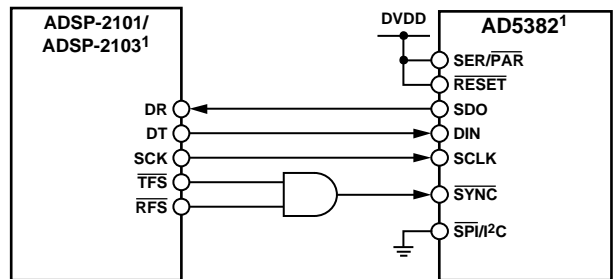

¹ADDITIONAL PINS OMITTED FOR CLARITY.

Figure 37. AD5382-to-ADSP-2101/ADSP-2103 Interface

APPLICATION INFORMATION

POWER SUPPLY DECOUPLING

In any circuit where accuracy is important, careful consideration of the power supply and ground return layout helps to ensure the rated performance. The printed circuit board on which the AD5382 is mounted should be designed so that the analog and digital sections are separated and confined to certain areas of the board. If the AD5382 is in a system where multiple devices require an AGND-to-DGND connection, the connection should be made at one point only, a star ground point established as close to the device as possible.

For supplies with multiple pins (AVDD, DVDD), these pins should be tied together. The AD5382 should have ample supply bypassing of 10 μF in parallel with 0.1 μF on each supply, located as close as possible to the package and ideally right up against the device. The 10 μF capacitors are the tantalum bead type. The 0.1 μF capacitor should have low effective series resistance (ESR) and effective series inductance (ESI), like the common ceramic types that provide a low impedance path to ground at high frequencies, to handle transient currents due to internal logic switching.

The power supply lines of the AD5382 should use as large a trace as possible to provide low impedance paths and reduce the effects of glitches on the power supply line. Fast switching signals such as clocks should be shielded with digital ground to avoid radiating noise to other parts of the board, and should never be run near the reference inputs. A ground line routed between the D_{IN} and SCLK lines helps reduce crosstalk between them. This is not required on a multilayer board because there is a separate ground plane, but separating the lines helps. It is essential to minimize noise on the VIN and REFIN lines.

Avoid crossover of digital and analog signals. Traces on opposite sides of the board should run at right angles to each other. This reduces the effects of feedthrough through the board. A microstrip technique is by far the best, but is not always possible with a double-sided board. In this technique, the component side of the board is dedicated to the ground plane while signal traces are placed on the solder side.

TYPICAL CONFIGURATION CIRCUIT

Figure 38 shows a typical configuration for the AD5382-5 when configured for use with an external reference. In the circuit shown, all AGND, SIGNAL_GND, and DAC_GND pins are tied together to a common AGND. AGND and DGND are connected together at the AD5382 device. On power-up, the AD5382 defaults to external reference operation. All AVDD lines are connected together and driven from the same 5 V source. It is recommended to decouple close to the device with a 0.1 μF ceramic and a 10 μF tantalum capacitor.

In this application, the reference for the AD5382-5 is provided externally from either an ADR421 or ADR431 2.5 V reference. Suitable external references for the AD5382-3 include the ADR280 1.2 V reference. The reference should be decoupled at the REFOUT/REFIN pin of the device with a 0.1 μF capacitor.

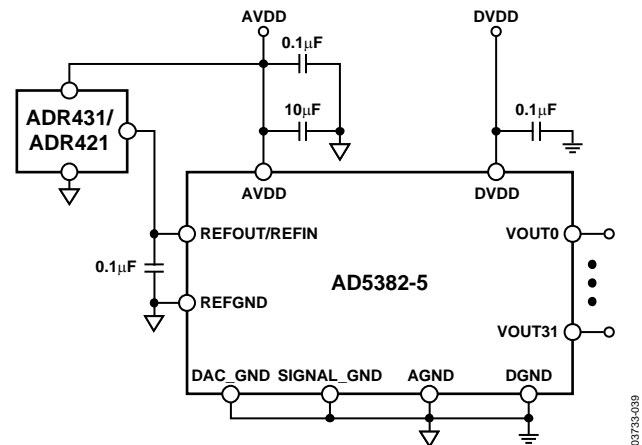

Figure 38. Typical Configuration with External Reference

Figure 39 shows a typical configuration when using the internal reference. On power-up, the AD5382 defaults to an external reference; therefore, the internal reference needs to be configured and turned on via a write to the AD5382 control register. Control Register Bit CR12 allows the user choose the reference value; Bit CR 10 is used to select the internal reference. It is recommended to use the 2.5 V reference when AVDD = 5 V, and the 1.25 V reference when AVDD = 3 V.

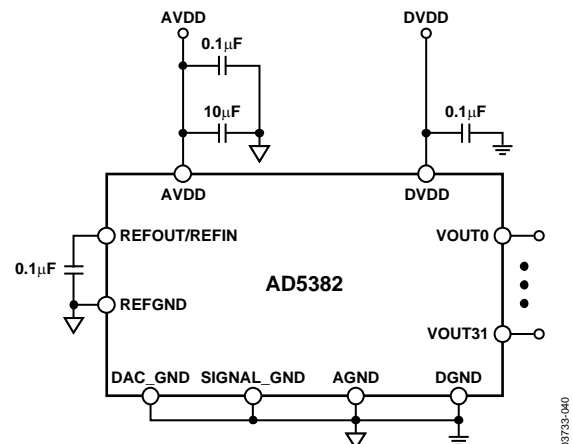

Figure 39. Typical Configuration with Internal Reference

Digital connections have been omitted for clarity. The AD5382 contains an internal power-on reset circuit with a 10 ms brown-out time. If the power supply ramp rate exceeds 10 ms, the user should reset the AD5382 as part of the initialization process to ensure the calibration data is loaded correctly into the device.

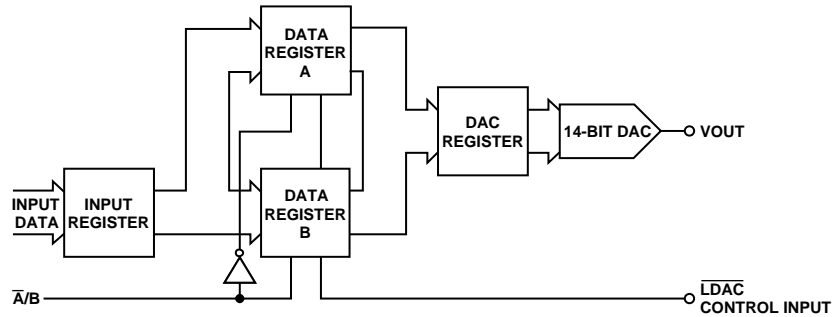

Figure 41. Toggle Mode Function

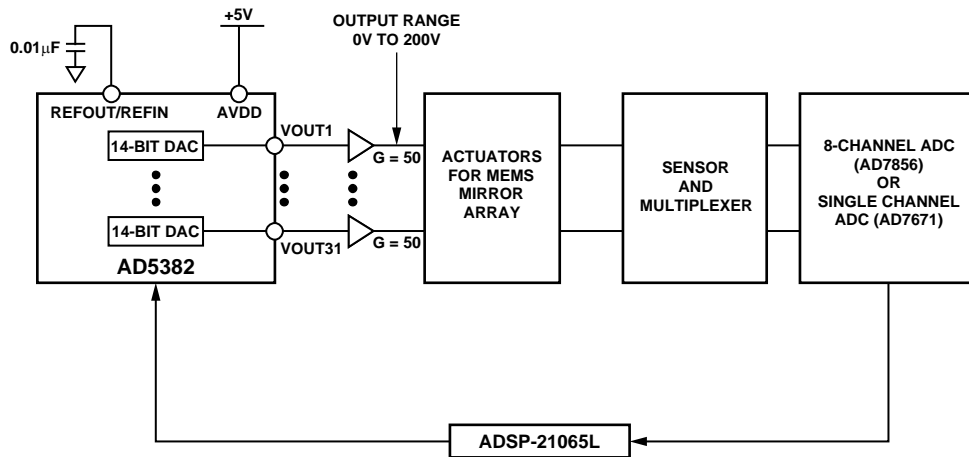

Figure 42. AD5382 in a MEMS Based Optical Switch

THERMAL MONITOR FUNCTION

The AD5382 contains a temperature shutdown function to protect the chip if multiple outputs are shorted. The short-circuit current of each output amplifier is typically 40 mA. Operating the AD5382 at 5 V leads to a power dissipation of 200 mW per shorted amplifier. With five channels shorted, this leads to an extra watt of power dissipation. For the 100-lead LQFP, the θ_{JA} is typically 44°C/W.

The thermal monitor is enabled by the user via CR8 in the control register. The output amplifiers on the AD5382 are automatically powered down if the die temperature exceeds approximately 130°C. After a thermal shutdown occurs, the user can re-enable the part by executing a soft power-up if the temperature drops below 130°C or by turning off the thermal monitor function via the control register.

AD5382 IN A MEMS-BASED OPTICAL SWITCH

In their feed-forward control paths, MEMS-based optical switches require high resolution DACs that offer high channel density with 14-bit monotonic behavior. The 32-channel, 14-bit AD5382 DAC satisfies these requirements. In the circuit in Figure 42, the 0 V to 5 V outputs of the AD5382 are amplified to achieve an output range of 0 V to 200 V, which is used to control actuators that determine the position of MEMS mirrors in an optical switch. The exact position of each mirror is measured using sensors. The sensor outputs are multiplexed into a high resolution ADC in determining the mirror position. The control loop is closed and driven by an ADSP-21065L, a 32-bit SHARC® DSP with an SPI-compatible SPORT interface. The ADSP-21065L writes data to the DAC, controls the multiplexer, and reads data from the ADC via the serial interface.

OPTICAL ATTENUATORS

Based on its high channel count, high resolution, monotonic behavior, and high level of integration, the AD5382 is ideally targeted at optical attenuation applications used in dynamic gain equalizers, variable optical attenuators (VOA), and optical add-drop multiplexers (OADM). In these applications, each wavelength is individually extracted using an arrayed wave guide; its power is monitored using a photodiode, transimpedance amplifier and ADC in a closed-loop control system.

The AD5382 controls the optical attenuator for each wavelength, ensuring that the power is equalized in all wavelengths before being multiplexed onto the fiber. This prevents information loss and saturation from occurring at amplification stages further along the fiber.

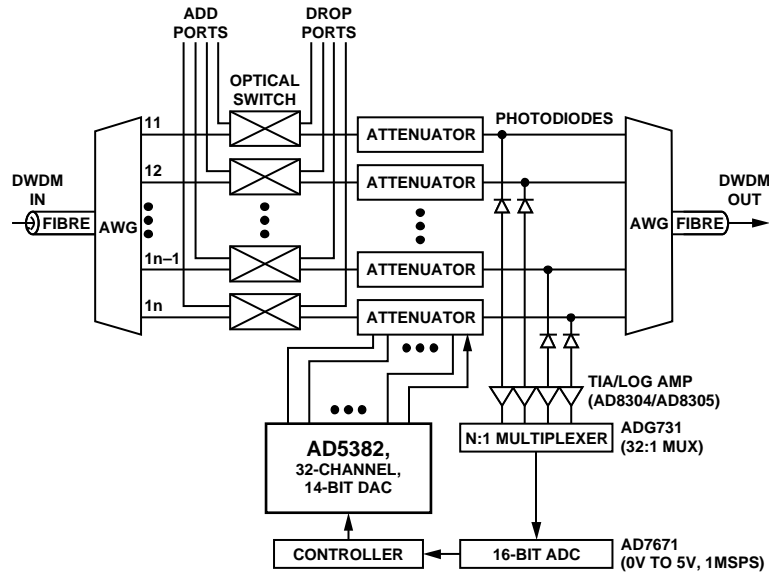
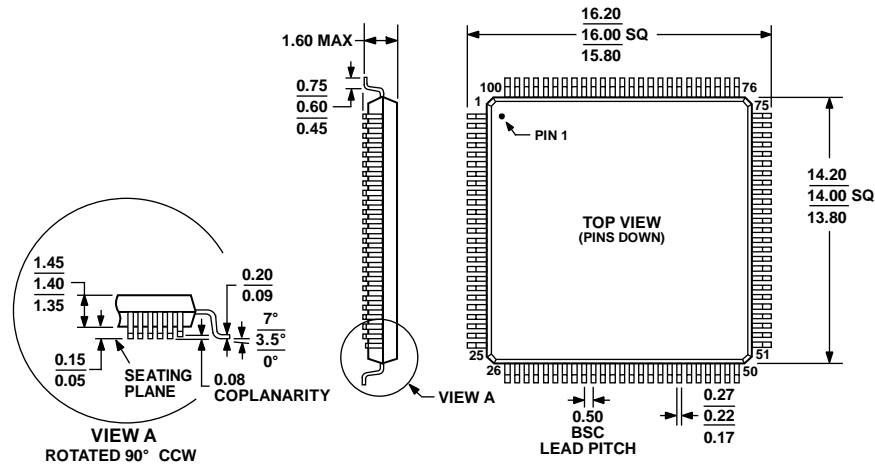

Figure 43. OADM Using the AD5382 as Part of an Optical Attenuator

037733-044

OUTLINE DIMENSIONS



COMPLIANT TO JEDEC STANDARDS MS-026-BED

Figure 44. 100-Lead Low Profile Quad Flat package [LQFP] (ST-100-1)
Dimensions shown in millimeters

061706-A

ORDERING GUIDE

Model ¹	Resolution	Temperature Range	AVDD Range	Output Channels	Linearity Error	Package Description	Package Option
AD5382BSTZ-3	14 Bits	-40°C to +85°C	2.7 V to 3.6 V	32	±4 LSB	100-Lead LQFP	ST-100-1
AD5382BSTZ-5	14 Bits	-40°C to +85°C	4.5 V to 5.5 V	32	±4 LSB	100-Lead LQFP	ST-100-1
EVAL-AD5382EBZ						Evaluation Kit	

¹ Z = RoHS Compliant Part.

NOTES

NOTES

NOTES

I²C refers to a communications protocol originally developed by Philips Semiconductors (now NXP Semiconductors).



Компания «ЭлектроПласт» предлагает заключение долгосрочных отношений при поставках импортных электронных компонентов на взаимовыгодных условиях!

Наши преимущества:

- Оперативные поставки широкого спектра электронных компонентов отечественного и импортного производства напрямую от производителей и с крупнейших мировых складов;
- Поставка более 17-ти миллионов наименований электронных компонентов;
- Поставка сложных, дефицитных, либо снятых с производства позиций;
- Оперативные сроки поставки под заказ (от 5 рабочих дней);
- Экспресс доставка в любую точку России;
- Техническая поддержка проекта, помощь в подборе аналогов, поставка прототипов;
- Система менеджмента качества сертифицирована по Международному стандарту ISO 9001;
- Лицензия ФСБ на осуществление работ с использованием сведений, составляющих государственную тайну;
- Поставка специализированных компонентов (Xilinx, Altera, Analog Devices, Intersil, Interpoint, Microsemi, Aeroflex, Peregrine, Syfer, Eurofarad, Texas Instrument, Miteq, Cobham, E2V, MA-COM, Hittite, Mini-Circuits, General Dynamics и др.);

Помимо этого, одним из направлений компании «ЭлектроПласт» является направление «Источники питания». Мы предлагаем Вам помощь Конструкторского отдела:

- Подбор оптимального решения, техническое обоснование при выборе компонента;
- Подбор аналогов;
- Консультации по применению компонента;
- Поставка образцов и прототипов;
- Техническая поддержка проекта;
- Защита от снятия компонента с производства.



Как с нами связаться

Телефон: 8 (812) 309 58 32 (многоканальный)

Факс: 8 (812) 320-02-42

Электронная почта: org@eplast1.ru

Адрес: 198099, г. Санкт-Петербург, ул. Калинина, дом 2, корпус 4, литера А.