



NTC Type SMD

Thermometrics Surface Mount Devices



Features

- Nickel barrier tin plated terminations for soldering
- High sensitivity to changes in temperature
- Wide operating temperature range -40°F to 257°F (-40°C to 125°C)
- Rugged construction
- Available in other material systems
- Intended for temperature measurement, control and compensation
- Suitable for standard soldering techniques
- Excellent solderability without “tombstoning”
- Ceramic between electrodes glass coated for improved stability
- Supplied in tape-and-reel packaging

Type NHQ Specification

Surface mount chip 1206 size

Description

A range of 1206 size surface mount NTC chip thermistors. The terminations are nickel barrier with tin plating.

General

Soldering Recommendations

- Maximum storage time in closed package: One year
- Maximum storage time exposed to ambient conditions of 59°F to 86°F (15°C to 30°C), 15% to 70% RH: 30 days
- Drying prior to soldering: Not to exceed 48h at 176°F (80°C) or 16h at 212°F (100°C) or 8h at 257°F (125°C)
- Flux type: R or RMA

Flow Soldering Conditions

- Preheat temperature: 176°F to 302°F (80°C to 150°C)
- Maximum rate of temperature change: 4.5°F/s or 2.5°C/s
- Maximum solder temperature: 509°F (265°C)
- Maximum dwell time: 10 seconds
- Cooling in ambient or air flow of 5m/s

Reflow Soldering Conditions

- Method infrared, hot gas, vapor
- Maximum rate of preheat temperature change: 4.5°F/s or 2.5°C/s
- Maximum temperature: 437°F (225°C)
- Maximum time above: 392°F (200°C) 30 seconds
- Maximum radiant flux: (0.1 to 100 W μ) 5 W/cm²
- Maximum hot air temperature: 527°F (275°C) at 4 m/s
- Maximum vapor temperature: 419°F (215°C)
- Maximum rate of cooling: 4.5°F/s or 2.5°C/s

Cleaning

Ultrasonic cleaning in methanol or isopropanol not exceeding 40 kHz for 5 minutes, or aqueous cleaning not exceeding 158°F (70°C) for 7 minutes (recommended).



NTC Type NHQ Outline Drawing

Code	R25 Ω	B (25/85)
NHQ202B410T5	2000	4100
NHQ222B410T5	2200	4100
NHQ252B410T5	2500	4100
NHQ302B410T5	3000	4100
NHQ472B355T5	4700	3550
NHQ502B355T5	5000	3550
NHQ103B375T5	10000	3750
NHQ153B400T5	15000	4000
NHQ203B400T5	20000	4000
NHQ223B400T5	22000	4000
NHQ303B400T5	30000	4000
NHQ333B400T5	33000	4000
NHQ473B400T5	47000	4000
NHQ503B400T5	50000	4000
NHQ104B425T5	100000	4250
NHQ154B425T5	150000	4250
NHQ304B435T5	300000	4350
NHQ474B435T5	470000	4350
NHQ504B435T5	500000	4350

Data

- Resistance tolerance at 77°F (25°C) ±5%; for ±10% replace T5 by T10 in code.
- Tolerance on B value ±200 K
- Minimum temperature: -40°F (-40°C)
- Maximum temperature: 257°F (125°C)
- Dissipation factor: 3 mW/K
- Time constant: 8 seconds maximum

Type NHQM Specification

Surface mount chip 0805 size

Description

A range of 0805 size surface mount NTC chip thermistors. The terminations are nickel barrier with tin plating.

General

Soldering Recommendations

- Maximum storage time in closed package: One year
- Maximum storage time exposed to ambient conditions of 59°F to 86°F (15°C to 30°C), 15% to 70% RH: 30 days
- Drying prior to soldering: Not to exceed 48h at 176°F (80°C) or 16h at 212°F (100°C) or 8h at 257°F (125°C)
- Flux type: R or RMA

Flow Soldering Conditions

- Preheat temperature: 176°F to 302°F (80°C to 150°C)
- Maximum rate of temperature change: 4.5°F/s or 2.5°C/s
- Maximum solder temperature: 509°F (265°C)
- Maximum dwell time: 10 seconds
- Cooling in ambient or air flow of 5m/s

Reflow Soldering Conditions

- Method infrared, hot gas, vapor
- Maximum rate of preheat temperature change: 4.5°F/s or 2.5°C/s
- Maximum temperature: 437°F (225°C)
- Maximum time above: 392°F (200°C) 30 seconds
- Maximum radiant flux: (0.1 to 100 W/μ) 5 W μ/cm²
- Maximum hot air temperature: 527°F (275°C) at 4 m/s
- Maximum vapor temperature: 419°F (215°C)
- Maximum rate of cooling: 4.5°F/s or 2.5°Cs

Cleaning

Ultrasonic cleaning in methanol or isopropanol not exceeding 40 kHz for 5 minutes, or aqueous cleaning not exceeding 158°F (70°C) for 7 minutes (recommended).



NTC Type NHQM Outline Drawing

Code	R25 Ω	B (25/85°C)
NHQM202B410T5	2000	4100
NHQM252B410T5	2500	4100
NHQM272B410T5	2700	4100
NHQM302B410T5	3000	4100
NHQM472B355T5	4700	3550
NHQM502B355T5	5000	3550
NHQM682B375T5	6800	3750
NHQM103B375T5	10000	3750
NHQM153B400T5	15000	4000
NHQM203B400T5	20000	4000
NHQM223B400T5	22000	4000
NHQM273B400T5	27000	4000
NHQM303B400T5	30000	4000
NHQM333B400T5	33000	4000
NHQM473B415T5	47000	4150
NHQM503B415T5	50000	4150
NHQM104B425T5	100000	4250
NHQM154B425T5	150000	4250
NHQM304B425T5	300000	4250
NHQM474B435T5	470000	4350
NHQM504B435T5	500000	4350

Data

- Resistance tolerance at 77°F (25°C) ±5%; for ±10% replace T5 by T10 in code.
- Tolerance on B value ±200 K
- Minimum temperature: -40°F (-40°C)
- Maximum temperature: 257°F (125°C)
- Dissipation factor: 1.5 mW/K
- Time constant: 5 seconds maximum

Type NHQMM Specification

Surface mount chip 0603 size

Description

A range of 0603 size surface mount NTC chip thermistors. The terminations are nickel barrier with tin plating.

General

Soldering Recommendations

- Maximum storage time in closed package: One year
- Maximum storage time exposed to ambient conditions of 59°F to 86°F (15°C to 30°C), 15% to 70% RH: 30 days
- Drying prior to soldering: Not to exceed 48h at 176°F (80°C) or 16h at 212°F (100°C) or 8h at 257°F (125°C)
- Flux type: R or RMA

Flow Soldering Conditions

- Preheat temperature: 176°F to 302°F (80°C to 150°C)
- Maximum rate of temperature change: 4.5°F/s or 2.5°C/s
- Maximum solder temperature: 509°F (265°C)
- Maximum dwell time: 10 seconds
- Cooling in ambient or air flow of 5m/s

Reflow Soldering Conditions

- Method infrared, hot gas, vapor
- Maximum rate of preheat temperature change: 4.5°F/s or 2.5°C/s
- Maximum temperature: 437°F (225°C)
- Maximum time above: 392°F (200°C) 30 seconds
- Maximum radiant flux: (0.1 to 100 W/μ) 5 W/μ/cm²
- Maximum hot air temperature: 527°F (275°C) at 4 m/s
- Maximum vapor temperature: 419°F (215°C)
- Maximum rate of cooling: 4.5°F/s or 2.5°C/s

Cleaning

Ultrasonic cleaning in methanol or isopropanol not exceeding 40 kHz for 5 minutes, or aqueous cleaning not exceeding 158°F (70°C) for 7 minutes (recommended).

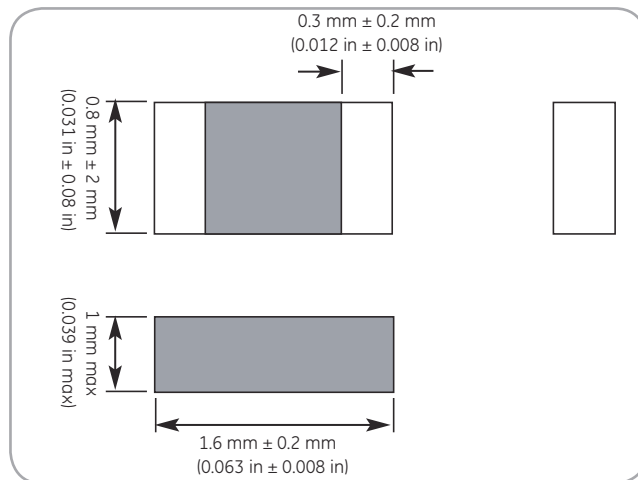

NTC Type NHQMM Outline Drawing

Code	R25 Ω	B (25/85)
NHQMM202B410T5	2000	4100
NHQMM222B410T5	2200	4100
NHQMM302B410T5	3000	4100
NHQMM332B410T5	3300	4100
NHQMM472B355T5	4700	3550
NHQMM502B355T5	5000	3550
NHQMM682B355T5	6800	3550
NHQMM103B375T5	10000	3750
NHQMM153B380T5	15000	3800
NHQMM203B380T5	20000	3800
NHQMM223B380T5	22000	3800
NHQMM303B400T5	30000	4000
NHQMM333B400T5	33000	4000
NHQMM473B400T5	47000	4000
NHQMM503B400T5	50000	4000
NHQMM683B400T5	68000	4000
NHQMM104B415T5	100000	4150
NHQMM154B425T5	150000	4250
NHQMM204B425T5	200000	4250

Data

- Resistance tolerance at 77°F (25°C) ±5%; for ±10% replace T5 by T10 in code
- Tolerance on B value ±200 K
- Minimum temperature: -40°F (-40°C)
- Maximum temperature: 257°F (125°C)
- Dissipation factor: 1.2 mW/K
- Time constant: 4 seconds maximum

Type NHQT Specification

Surface mount chip 0402 size

Description

A range of 0402 size surface mount NTC chip thermistors. The terminations are nickel barrier with tin plating.

General

Soldering Recommendations

- Maximum storage time in closed package: One year
- Maximum storage time exposed to ambient conditions of 59°F to 86°F (15°C to 30°C), 15% to 70% RH: 30 days
- Drying prior to soldering: Not to exceed 48h at 176°F (80°C) or 16h at 212°F (100°C) or 8h at 257°F (125°C)
- Flux type: R or RMA

Flow Soldering Conditions

- Preheat temperature: 176°F to 302°F (80°C to 150°C)
- Maximum rate of temperature change: 4.5°F/s or 2.5°C/s
- Maximum solder temperature: 509°F (265°C)
- Maximum dwell time: 10 seconds
- Cooling in ambient or air flow of 5m/s

Reflow Soldering Conditions

- Method infrared, hot gas, vapor
- Maximum rate of preheat temperature change: 4.5°F/s or 2.5°C/s
- Maximum temperature: 437°F (225°C)
- Maximum time above: 392°F (200°C) 30 seconds
- Maximum radiant flux: (0.1 to 100 W μ) 5 W μ /cm²
- Maximum hot air temperature: 527°F (275°C) at 4 m/s
- Maximum vapor temperature: 419°F (215°C)
- Maximum rate of cooling: 4.5°F/s or 2.5°C/s

Cleaning

Ultrasonic cleaning in methanol or isopropanol not exceeding 40 kHz for 5 minutes, or aqueous cleaning not exceeding 158°F (70°C) for 7 minutes (recommended).



NTC Type NHQT Outline Drawing

Code	R25 Ω	B (25/85)
NHQT500B285T5	50	2850
NHQT202B410T5	2000	4100
NHQT252B410T5	2500	4100
NHQT332B410T5	3300	4100
NHQT352B410T5	3500	4100
NHQT402B410T5	4000	4100
NHQT652B410T5	6500	4100
NHQT153B380T5	15000	3800
NHQT203B380T5	20000	3800
NHQT223B380T5	22000	3800
NHQT303B400T5	30000	4000
NHQT473B400T5	47000	4000
NHQT683B400T5	68000	4000
NHQT154B425T5	150000	4250

Data

- Resistance tolerance at 77°F (25°C) $\pm 5\%$; for $\pm 10\%$ replace T5 by T10 in code
- Tolerance on B value ± 200 K
- Minimum temperature: -40°F (-40°C)
- Maximum temperature: 257°F (125°C)
- Dissipation factor: 1.5 mW/K
- Time constant: 4 seconds maximum

Amphenol

Advanced Sensors

www.amphenol-sensors.com

© 2017 Amphenol Corporation. All Rights Reserved. Specifications are subject to change without notice. Other company names and product names used in this document are the registered trademarks or trademarks of their respective owners.

Mouser Electronics

Authorized Distributor

Click to View Pricing, Inventory, Delivery & Lifecycle Information:

Amphenol:

[NHQ223R10](#) [NHQ103B375T10](#) [NHQ504R10](#) [NHQ104B425T10](#) [NHQ102B325T10](#) [NHQ103B375T5](#)
[NHQ154B425T5](#) [NHQ304B435T10](#) [NHQ223B400T5](#) [NHQ503B400T5](#) [NHQ252B410T10](#) [NHQ272B410T10](#)
[NHQ152B345T5](#) [NHQ504B435T10](#) [NHQ801B325T5](#) [NHQ333B400T10](#) [NHQ472B355T5](#) [NHQ473B400T10](#)
[NHQ102B325T5](#) [NHQ303B400T5](#) [NHQ153B400T10](#) [NHQ203B400T10](#) [NHQ104B425T5](#) [NHQ503B400T10](#)
[NHQ203B400T5](#) [NHQ501B325T5](#) [NHQ302B410T10](#) [NHQ303B400T10](#) [NHQ302B410T5](#) [NHQ504B435T5](#)
[NHQ153B400T5](#) [NHQ333B400T5](#) [NHQ222B410T5](#) [NHQ101B280T5](#) [NHQ272B410T5](#) [NHQ472B355T10](#)
[NHQ474B435T5](#) [NHQ502B355T10](#) [NHQ101B280T10](#) [NHQ502B355T5](#) [NHQ152B345T10](#) [NHQ223B400T10](#)
[NHQ801B325T10](#) [NHQ304B435T5](#) [NHQ501B325T10](#) [NHQ202B410T10](#) [NHQ252B410T5](#) [NHQ202B410T5](#)
[NHQ222B410T10](#) [NHQ474B435T10](#) [NHQ154B425T10](#) [NHQ473B400T5](#)



Компания «ЭлектроПласт» предлагает заключение долгосрочных отношений при поставках импортных электронных компонентов на взаимовыгодных условиях!

Наши преимущества:

- Оперативные поставки широкого спектра электронных компонентов отечественного и импортного производства напрямую от производителей и с крупнейших мировых складов;
- Поставка более 17-ти миллионов наименований электронных компонентов;
- Поставка сложных, дефицитных, либо снятых с производства позиций;
- Оперативные сроки поставки под заказ (от 5 рабочих дней);
- Экспресс доставка в любую точку России;
- Техническая поддержка проекта, помощь в подборе аналогов, поставка прототипов;
- Система менеджмента качества сертифицирована по Международному стандарту ISO 9001;
- Лицензия ФСБ на осуществление работ с использованием сведений, составляющих государственную тайну;
- Поставка специализированных компонентов (Xilinx, Altera, Analog Devices, Intersil, Interpoint, Microsemi, Aeroflex, Peregrine, Syfer, Eurofarad, Texas Instrument, Miteq, Cobham, E2V, MA-COM, Hittite, Mini-Circuits, General Dynamics и др.);

Помимо этого, одним из направлений компании «ЭлектроПласт» является направление «Источники питания». Мы предлагаем Вам помощь Конструкторского отдела:

- Подбор оптимального решения, техническое обоснование при выборе компонента;
- Подбор аналогов;
- Консультации по применению компонента;
- Поставка образцов и прототипов;
- Техническая поддержка проекта;
- Защита от снятия компонента с производства.



Как с нами связаться

Телефон: 8 (812) 309 58 32 (многоканальный)

Факс: 8 (812) 320-02-42

Электронная почта: org@eplast1.ru

Адрес: 198099, г. Санкт-Петербург, ул. Калинина, дом 2, корпус 4, литера А.