

Features

- Formerly J. W. Miller® model
- Six windings - multiple configurations
- Compact size
- Tape and reel packaging
- RoHS compliant*

Applications

- Inductors: Buck-boost, coupled, filtering, common mode
- Transformers: Flyback, push-pull, inverter, gate drive, isolation

PM600/PM610/PM620 Series - SMD Inductor/Transformer

Electrical Specifications

Bourns Part No.	Inductance 100 KHz		DCR (Ω) Max.	Isat (A)	Irms (A)	<1> ET (VmS) Based on 40 °C Rise (260 KHz)	<1> ET (VmS) Based on Core Saturation
	(μH)	Tol. (%)					
PM600-01-RC	201.6	±30	0.324	0.02	0.46	16.8	103.2
PM600-02-RC	89.6	±30	0.137	0.03	0.71	11.2	68.8
PM600-03-RC	27.4	±10	0.324	0.31	0.46	16.8	103.2
PM600-04-RC	12.2	±10	0.137	0.47	0.71	11.2	68.8
PM600-05-RC	14.7	±10	0.324	0.58	0.46	16.8	103.2
PM600-06-RC	6.5	±10	0.137	0.87	0.71	11.2	68.8
PM600-07-RC	10.9	±10	0.324	0.88	0.46	16.8	103.2
PM600-08-RC	4.9	±10	0.137	1.32	0.71	11.2	68.8
PM600-09-RC	8.5	±10	0.324	1.23	0.46	16.8	103.2
PM600-10-RC	3.8	±10	0.137	1.85	0.71	11.2	68.8
PM610-01-RC	160.0	±30	0.202	0.04	0.68	21.0	130
PM610-02-RC	78.4	±30	0.094	0.06	1.00	14.7	91
PM610-03-RC	21.6	±10	0.202	0.67	0.68	21.0	130
PM610-04-RC	10.6	±10	0.094	0.96	1.00	14.7	91
PM610-05-RC	11.6	±10	0.202	1.30	0.68	21.0	130
PM610-06-RC	5.7	±10	0.094	1.86	1.00	14.7	91
PM610-07-RC	8.3	±10	0.202	2.00	0.68	21.0	130
PM610-08-RC	4.1	±10	0.094	2.86	1.00	14.7	91
PM610-09-RC	6.6	±10	0.202	2.30	0.68	21.0	130
PM610-10-RC	3.2	±10	0.094	3.29	1.00	14.7	91
PM620-01-RC	160.6	±30	0.094	0.03	1.28	20.8	130
PM620-02-RC	77.0	±30	0.065	0.04	1.54	14.4	90
PM620-03-RC	131.8	±20	0.094	0.08	1.28	20.8	130
PM620-04-RC	63.2	±20	0.065	0.12	1.54	14.4	90
PM620-05-RC	23.3	±10	0.094	0.36	1.28	20.8	130
PM620-06-RC	11.2	±10	0.065	0.52	1.54	14.4	90
PM620-07-RC	14.2	±10	0.094	0.76	1.28	20.8	130
PM620-08-RC	6.8	±10	0.065	1.10	1.54	14.4	90
PM620-09-RC	9.3	±10	0.094	1.11	1.28	20.8	130
PM620-10-RC	4.5	±10	0.065	1.60	1.54	14.4	90
PM620-11-RC	7.9	±10	0.094	1.40	1.28	20.8	130
PM620-12-RC	3.8	±10	0.065	2.02	1.54	14.4	90

<1> Single or multi-windings in parallel. ET of multiple winding in series is number of windings times value of ET.

General Specifications

Rated Current..... Ind. drop of 30 % typ.
at Isat
 Temperature Rise ... 40 °C typical at Irms
 Operating Temperature
-40 °C to +105 °C
 Storage Temperature
-40 °C to +105 °C
 Soldering 245 °C, 5 seconds max.
 Dielectric Strength 500 Vrms
 between windings

Materials

Core..... Ferrite
 Wire Polyurethane-coated copper
 Terminal Coating..... Sn-Ag-Cu alloy
 Packaging
 PM600.....600 pcs. per 13-inch reel
 PM610.....300 pcs. per 13-inch reel
 PM620.....200 pcs. per 13-inch reel

*RoHS Directive 2002/95/EC Jan. 27, 2003 including annex and RoHS Recast 2011/65/EU June 8, 2011. Specifications are subject to change without notice. Customers should verify actual device performance in their specific applications.

Typical Configurations

Inductor:

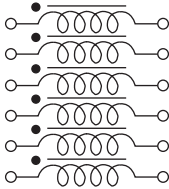

Basic Diagram
Inductance: L
Current: I

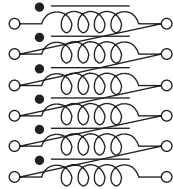

Figure 1
Inductance: 36 x L
Current: I

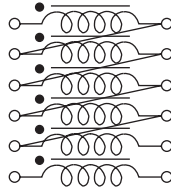

Figure 2
Inductance: 25 x L
Current: I

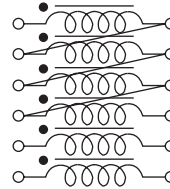

Figure 3
Inductance: 16 x L
Current: I

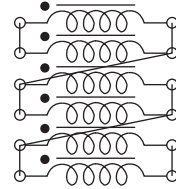

Figure 4
Inductance: 9 x L
Current: 2 x I

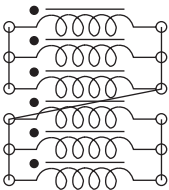

Figure 5
Inductance: 4 x L
Current: 3 x I

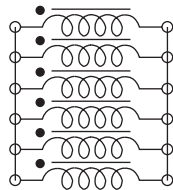
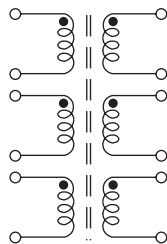

Figure 6
Inductance: L
Current: 6 x I

Transformer:



Basic Diagram
Turns Ratio:
1:1:1:1:1:1

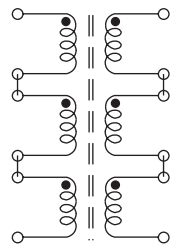

Figure 1
Turns Ratio:
1:1

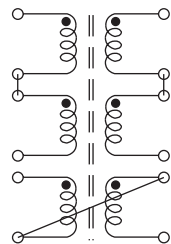

Figure 2
Turns Ratio:
1:1:1

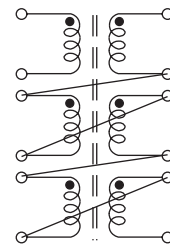

Figure 3
Turns Ratio:
1:5 or 5:1

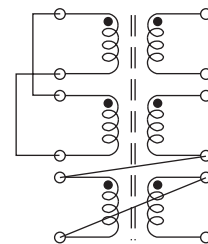

Figure 4
Turns Ratio:
1:4 or 4:1

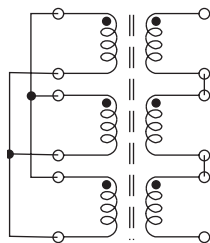

Figure 5
Turns Ratio:
1:3 or 3:1

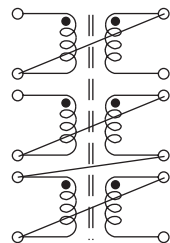

Figure 6
Turns Ratio:
1:2 or 2:1

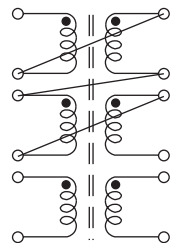

Figure 7
Turns Ratio:
4:1:1

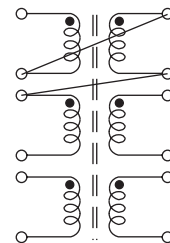

Figure 8
Turns Ratio:
3:1:1:1

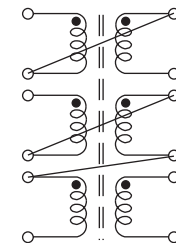

Figure 9
Turns Ratio:
2:3 or 3:2

PM600/PM610/PM620 Series - SMD Inductor/Transformer

BOURNS®

Product Dimensions

PM600 Series

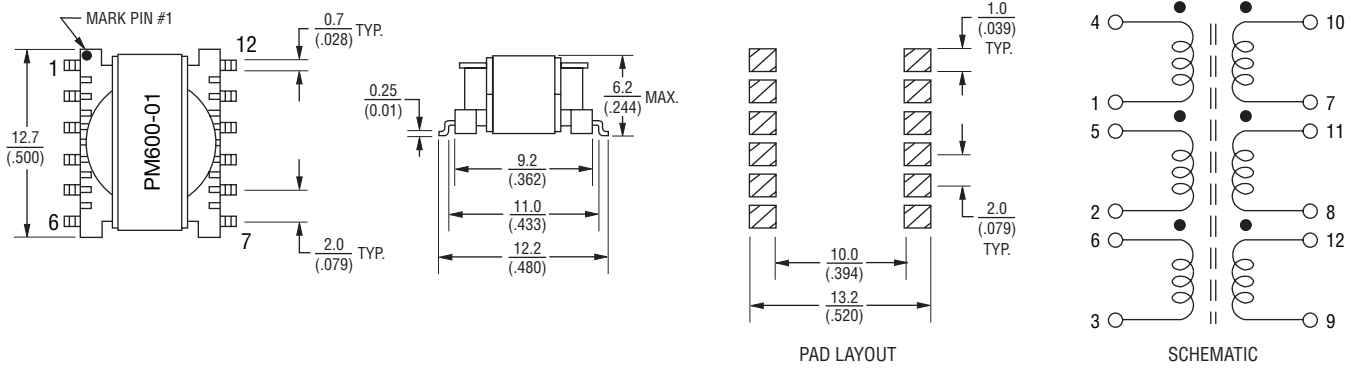

PM610 Series

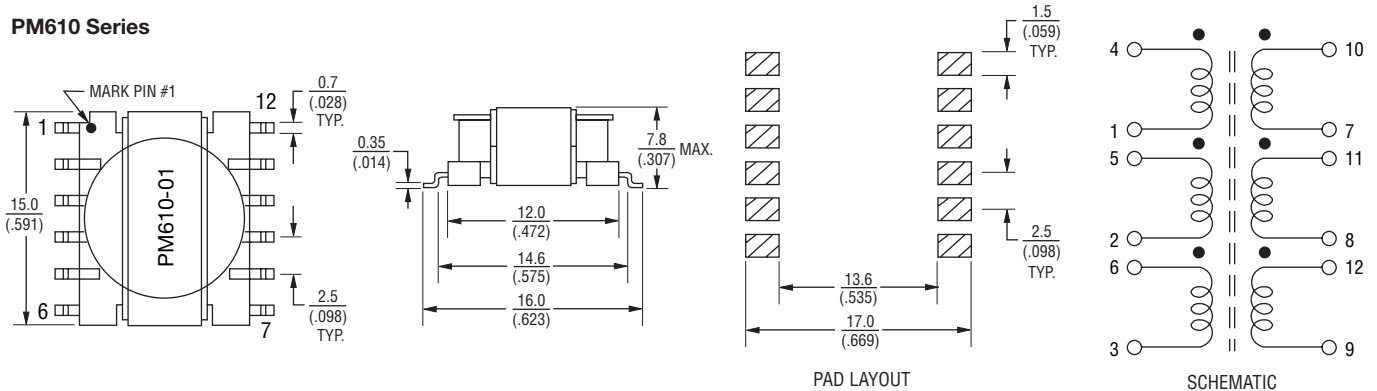

PM620 Series

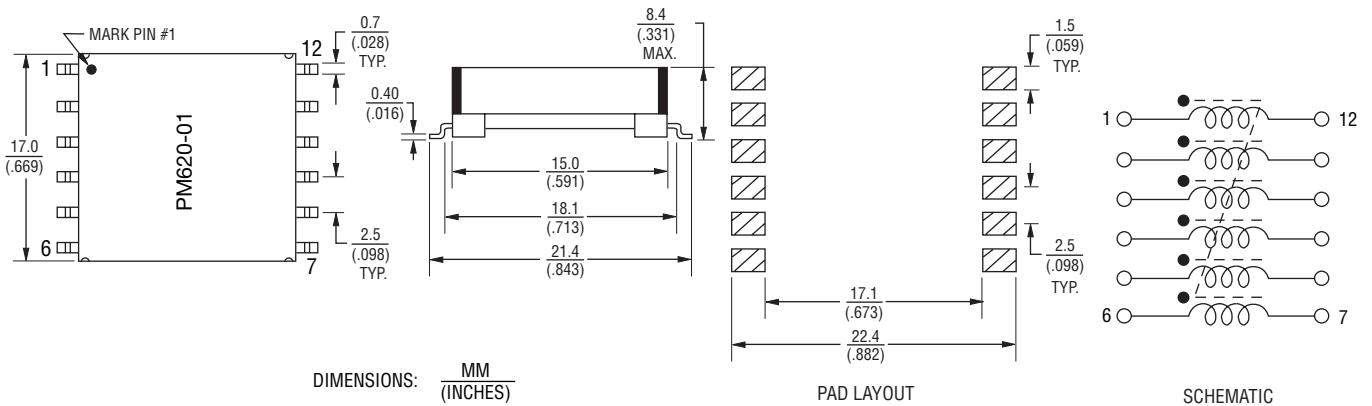

Specifications are subject to change without notice.
Customers should verify actual device performance in their specific applications.

PM600/PM610/PM620 Series - SMD Inductor/Transformer

BOURNS®

Packaging Specifications

PM600

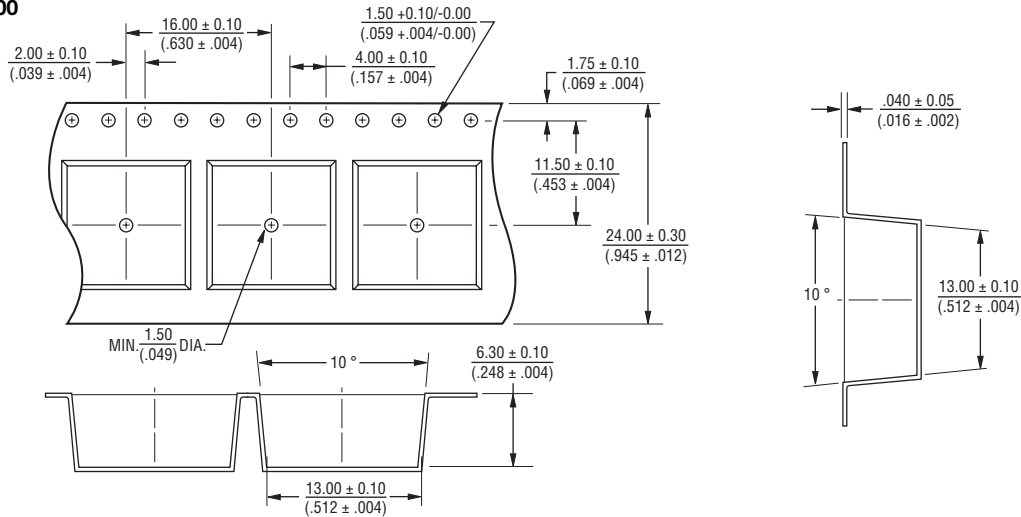

PM610

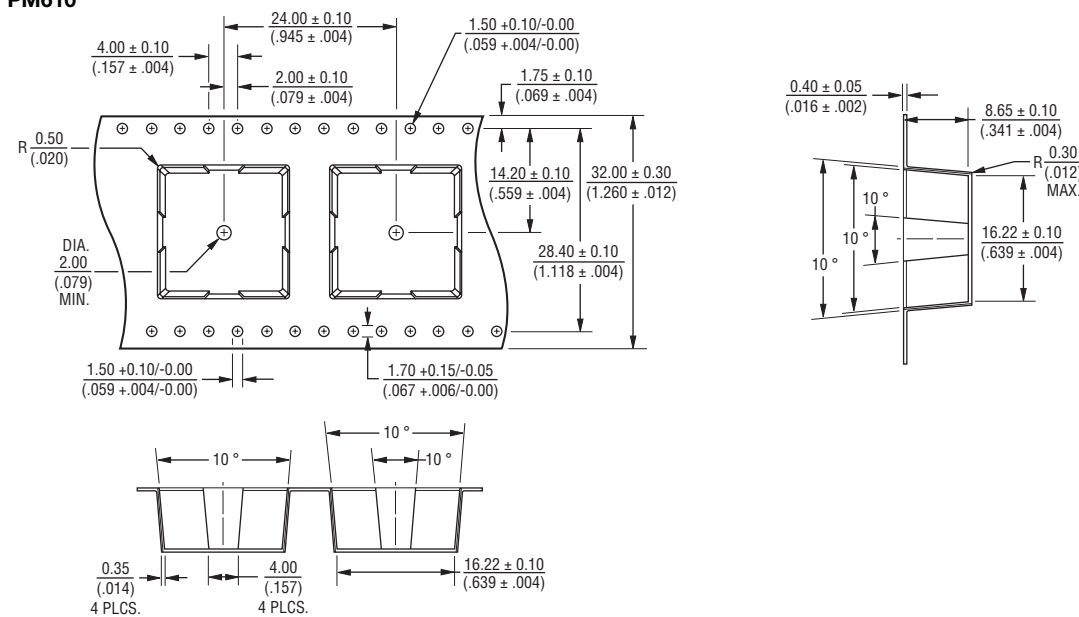

DIMENSIONS: $\frac{\text{MM}}{\text{(INCHES)}}$

PM600/PM610/PM620 Series - SMD Inductor/Transformer

BOURNS®

Packaging Specifications (Continued)

PM620

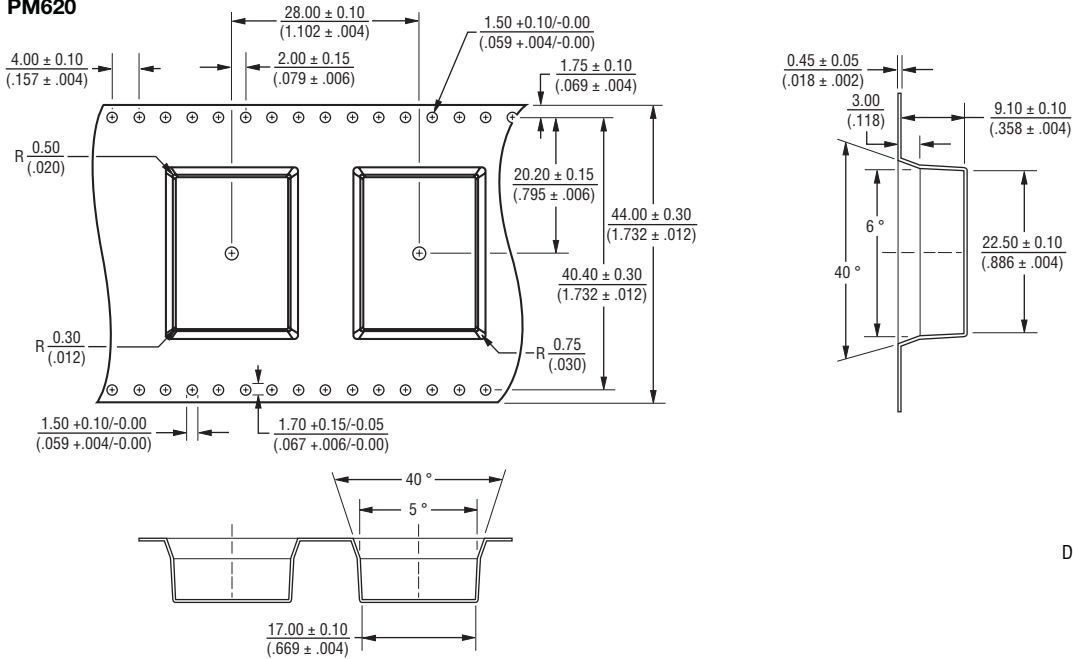

DIMENSIONS: $\frac{\text{MM}}{\text{(INCHES)}}$

<1> Single or multi-windings in parallel. ET of multiple winding in series is number of windings times value of ET.

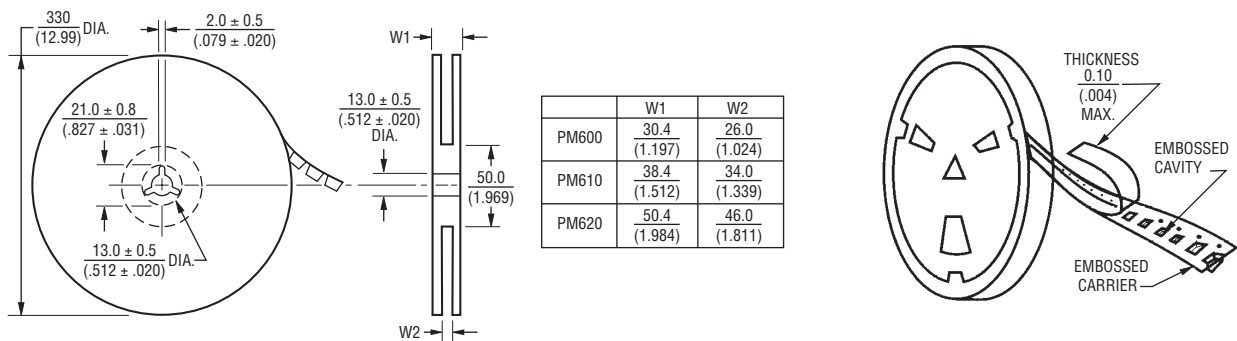

REV. 06/08

Specifications are subject to change without notice.
Customers should verify actual device performance in their specific applications.



Компания «ЭлектроПласт» предлагает заключение долгосрочных отношений при поставках импортных электронных компонентов на взаимовыгодных условиях!

Наши преимущества:

- Оперативные поставки широкого спектра электронных компонентов отечественного и импортного производства напрямую от производителей и с крупнейших мировых складов;
- Поставка более 17-ти миллионов наименований электронных компонентов;
- Поставка сложных, дефицитных, либо снятых с производства позиций;
- Оперативные сроки поставки под заказ (от 5 рабочих дней);
- Экспресс доставка в любую точку России;
- Техническая поддержка проекта, помощь в подборе аналогов, поставка прототипов;
- Система менеджмента качества сертифицирована по Международному стандарту ISO 9001;
- Лицензия ФСБ на осуществление работ с использованием сведений, составляющих государственную тайну;
- Поставка специализированных компонентов (Xilinx, Altera, Analog Devices, Intersil, Interpoint, Microsemi, Aeroflex, Peregrine, Syfer, Eurofarad, Texas Instrument, Miteq, Cobham, E2V, MA-COM, Hittite, Mini-Circuits, General Dynamics и др.);

Помимо этого, одним из направлений компании «ЭлектроПласт» является направление «Источники питания». Мы предлагаем Вам помощь Конструкторского отдела:

- Подбор оптимального решения, техническое обоснование при выборе компонента;
- Подбор аналогов;
- Консультации по применению компонента;
- Поставка образцов и прототипов;
- Техническая поддержка проекта;
- Защита от снятия компонента с производства.



Как с нами связаться

Телефон: 8 (812) 309 58 32 (многоканальный)

Факс: 8 (812) 320-02-42

Электронная почта: org@eplast1.ru

Адрес: 198099, г. Санкт-Петербург, ул. Калинина, дом 2, корпус 4, литера А.