



Is Now Part of



ON Semiconductor®

To learn more about ON Semiconductor, please visit our website at
www.onsemi.com

Please note: As part of the Fairchild Semiconductor integration, some of the Fairchild orderable part numbers will need to change in order to meet ON Semiconductor's system requirements. Since the ON Semiconductor product management systems do not have the ability to manage part nomenclature that utilizes an underscore (_), the underscore (_) in the Fairchild part numbers will be changed to a dash (-). This document may contain device numbers with an underscore (_). Please check the ON Semiconductor website to verify the updated device numbers. The most current and up-to-date ordering information can be found at www.onsemi.com. Please email any questions regarding the system integration to Fairchild_questions@onsemi.com.

ON Semiconductor and the ON Semiconductor logo are trademarks of Semiconductor Components Industries, LLC dba ON Semiconductor or its subsidiaries in the United States and/or other countries. ON Semiconductor owns the rights to a number of patents, trademarks, copyrights, trade secrets, and other intellectual property. A listing of ON Semiconductor's product/patent coverage may be accessed at www.onsemi.com/site/pdf/Patent-Marking.pdf. ON Semiconductor reserves the right to make changes without further notice to any products herein. ON Semiconductor makes no warranty, representation or guarantee regarding the suitability of its products for any particular purpose, nor does ON Semiconductor assume any liability arising out of the application or use of any product or circuit, and specifically disclaims any and all liability, including without limitation special, consequential or incidental damages. Buyer is responsible for its products and applications using ON Semiconductor products, including compliance with all laws, regulations and safety requirements or standards, regardless of any support or applications information provided by ON Semiconductor. "Typical" parameters which may be provided in ON Semiconductor data sheets and/or specifications can and do vary in different applications and actual performance may vary over time. All operating parameters, including "Typicals" must be validated for each customer application by customer's technical experts. ON Semiconductor does not convey any license under its patent rights nor the rights of others. ON Semiconductor products are not designed, intended, or authorized for use as a critical component in life support systems or any FDA Class 3 medical devices or medical devices with a same or similar classification in a foreign jurisdiction or any devices intended for implantation in the human body. Should Buyer purchase or use ON Semiconductor products for any such unintended or unauthorized application, Buyer shall indemnify and hold ON Semiconductor and its officers, employees, subsidiaries, affiliates, and distributors harmless against all claims, costs, damages, and expenses, and reasonable attorney fees arising out of, directly or indirectly, any claim of personal injury or death associated with such unintended or unauthorized use, even if such claim alleges that ON Semiconductor was negligent regarding the design or manufacture of the part. ON Semiconductor is an Equal Opportunity/Affirmative Action Employer. This literature is subject to all applicable copyright laws and is not for resale in any manner.



FAN3988 USB/Charger and Over-Voltage Detection Device

Features

- Charger/USB Detection Device
- Charger/USB Device Detection Flag
- Over-/Under-Voltage Detection Flag
- V_{BUS} Supply: 2.7 V to 20 V
- C_{ON} of 1.5 pF
- 6-Lead MicroPak™ MLP Package

Applications

- Mobile Phones
- Handheld Devices

Description

The FAN3988 is a USB-connection-monitoring device used to determine if a standard USB device or a battery-charging device is connected.

The FAN3988 sets the FLAG1 pin to logic HIGH or LOW as an indicator to the system controller that a standard USB device or a charger is connected to the USB port. The FAN3988 also monitors the V_{BUS} for over- or under-voltage conditions. The FLAG2 pin is set LOW if V_{BUS} is less than 3.3 V or greater than 6.0 V.

The FAN3988 is packaged in a very small 6-lead MicroPak™ MLP package suitable for small board space applications, such as mobile phones.

Ordering Information

Part Number	Operating Temperature Range	Package	Packing Method	Quantity
FAN3988IL6X	-40°C to +85°C	6-Lead MicroPak™ MLP Package	Reel	5000
FAN3988IL6X_F113 ⁽¹⁾				

Note:

1. Legacy product number; please order FAN3988IL6X for new designs.

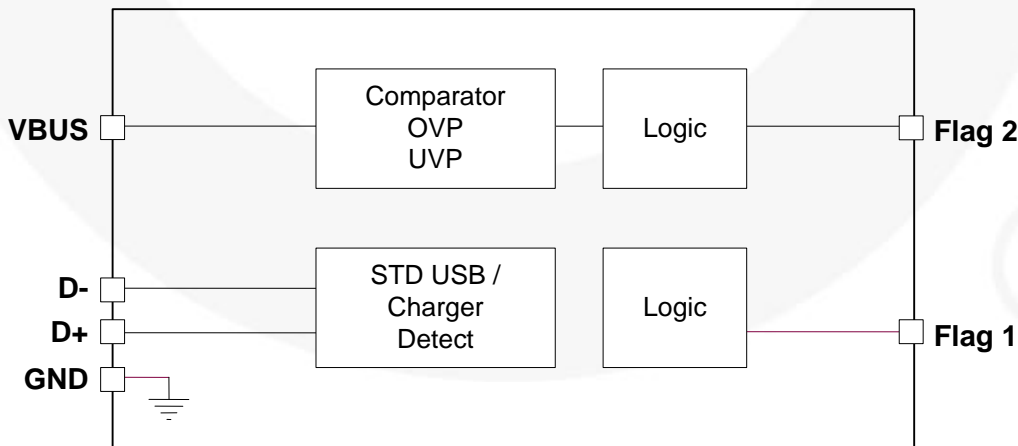

Figure 1. Block Diagram

Pin Configuration

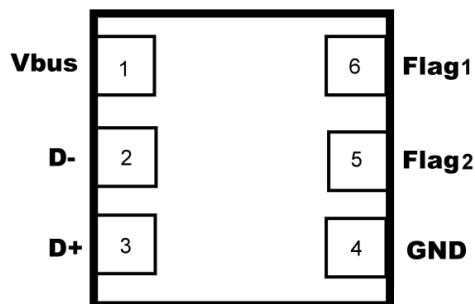

Figure 2. Pin Configuration (Top View)

Pin Definitions

Pin#	Name	Type	Description
1	Vbus	Input	Power input from charger, USB device, or handheld battery
2	D-	Input	USB data input
3	D+	Input	USB data input
4	Gnd	Input	Device ground
5	Flag2	Output	Over/under-voltage flag output
6	Flag1	Output	Charger/standard USB device detect flag

Truth Table

Connection State	V _{BUS} (V)	D-	D+	FLAG1	FLAG2
STD USB Device ⁽²⁾	0	Open	Open	LOW	LOW
STD USB Device	0	R to GND	R to GND	LOW	LOW
STD USB Device	5	R to GND	R to GND	LOW	HIGH
USB Charger	5	Short to D+	Short to D-	HIGH	HIGH
V _{BUS} > 6 V	> 6	Short to D+	Short to D-	HIGH	LOW
V _{BUS} < 3.3 V	< 3.3	Short to D+	Short to D-	HIGH	LOW
PC Data/Charger	5	Open	Open	LOW	HIGH

Note:

2. See Figure 7.

Absolute Maximum Ratings

Stresses exceeding the absolute maximum ratings may damage the device. The device may not function or be operable above the recommended operating conditions and stressing the parts to these levels is not recommended. In addition, extended exposure to stresses above the recommended operating conditions may affect device reliability. The absolute maximum ratings are stress ratings only.

Symbol	Parameter	Min.	Max.	Unit
V _{BUS}	DC Supply Voltage	-0.3	20.0	V

Reliability Information

Symbol	Parameter	Min.	Typ.	Max.	Unit
T _J	Junction Temperature			+150	°C
T _{STG}	Storage Temperature Range	-65		+150	°C
θ _{JA}	Thermal Resistance, JEDEC Standard, Multi-layer Test Boards, Still Air		41		°C/W

ESD Information

Symbol	Parameter		Max.	Unit
ESD	Electrostatic Discharge Information	Human Body Model, JESD22-A114	5	kV
		Charged Device Model, JESD22-C101	2	

Recommended Operating Conditions

The Recommended Operating Conditions table defines the conditions for actual device operation. Recommended operating conditions are specified to ensure optimal performance to the datasheet specifications. Fairchild does not recommend exceeding them or designing to Absolute Maximum Ratings.

Symbol	Parameter	Min.	Typ.	Max.	Unit
T _A	Operating Temperature Range	-40		+85	°C
V _{BUS}	Supply Voltage Range	2.7	5.0	20.0	V

DC Electrical Characteristics

$T_A = 25^\circ\text{C}$ and $V_{\text{BUS}} = 5.0\text{ V}$, unless otherwise noted.

Symbol	Parameter	Condition	Min.	Typ.	Max.	Unit
Supply						
V_{BUS}	Supply Voltage Range	V_{BUS} Range	2.7	5.0	20.0	V
I_{BUS}	Quiescent Supply Current	$V_{\text{BUS}} = +5.0\text{ V}$, D+ D- Shorted		1.2	2.0	mA
t_{SUPPLY}	Power-Up Stabilization Time	$V_{\text{BUS}} = +5.0\text{ V}$, D+ D- Shorted		10		ms
Input Characteristics						
$C_{\text{D+}}$	Input Capacitance			1.5	2.0	pF
$C_{\text{D-}}$	Input Capacitance			1.5	2.0	pF
$I_{\text{off D+}}$	Off Leakage Current	$V_{\text{BUS}} = 0\text{ V}$ or 5 V V_{IN} on D+ = 5 V		1		μA
$I_{\text{off D-}}$	Off Leakage Current	$V_{\text{BUS}} = 0\text{ V}$ or 5 V V_{IN} on D- = 5 V		1		μA
Output Characteristics						
OV_{DETECT}	Over-Voltage Threshold Detect	$V_{\text{BUS}} = +5.0\text{ V}$, Flag2 = LOW	5.8	6.0	6.5	V
OV_{HYST}	Over-Voltage Hysteresis	Voltage Sweep through Upper and Lower Trip Points		100		mV
UV_{DETECT}	Under-Voltage Threshold Detect	$V_{\text{BUS}} = +5.0\text{ V}$, Flag2 = LOW	3.0	3.3	3.6	V
UV_{HYST}	Under-Voltage Hysteresis	Voltage Sweep through Upper and Lower Trip Points		100		mV
$V_{\text{OH FLAG1/FLAG2}}$	Minimum HIGH Output Voltage	$V_{\text{BUS}} = +5.0\text{ V}$, $I_{\text{OH}} = -20\ \mu\text{A}$	2.4		2.6	V
$V_{\text{OL FLAG1/FLAG2}}$	Maximum LOW Output Voltage	$V_{\text{BUS}} = +5.0\text{ V}$, $I_{\text{OL}} = 20\ \mu\text{A}$			0.3	V
$I_{\text{OH FLAG1/FLAG2}}$	Minimum HIGH Output Current		-20			μA
$I_{\text{OL FLAG1/FLAG2}}$	Maximum HIGH Output Current				20	μA
D+/D- Threshold	USB SDP (Standard Downstream Port)	D+ = 3V; D- = 0V-3V or 3V-0V D- = 3V; D+ = 0V-3V or 3V-0V	1.025	1.300	1.365	V
	USB DCP (Dedicated Charging Port)	D+/D- = 0V-3V, 3V-0V		1.450		V
t_{off}	Flag2 HIGH to LOW	100 pF Load		10		ns
t_{on}	Flag2 LOW to HIGH	100 pF Load		44		ns

Typical Performance Characteristics

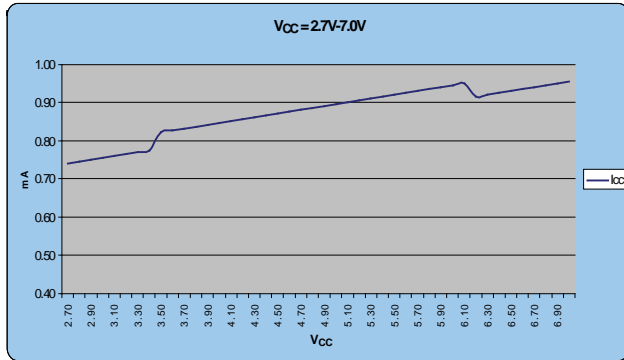

Figure 3. I_{Bus} vs. V_{Bus} (2.7 V-7.0 V) No Load

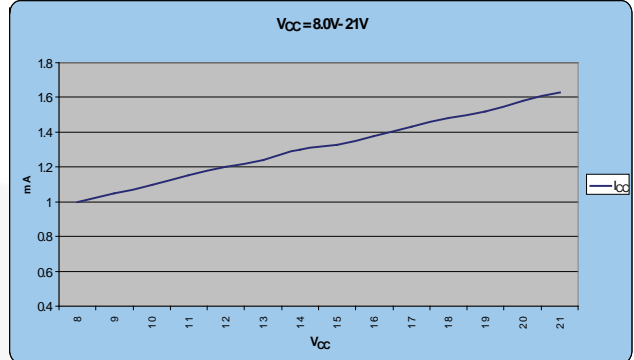

Figure 4. I_{Bus} vs. V_{Bus} (8.0V-21 V) No Load

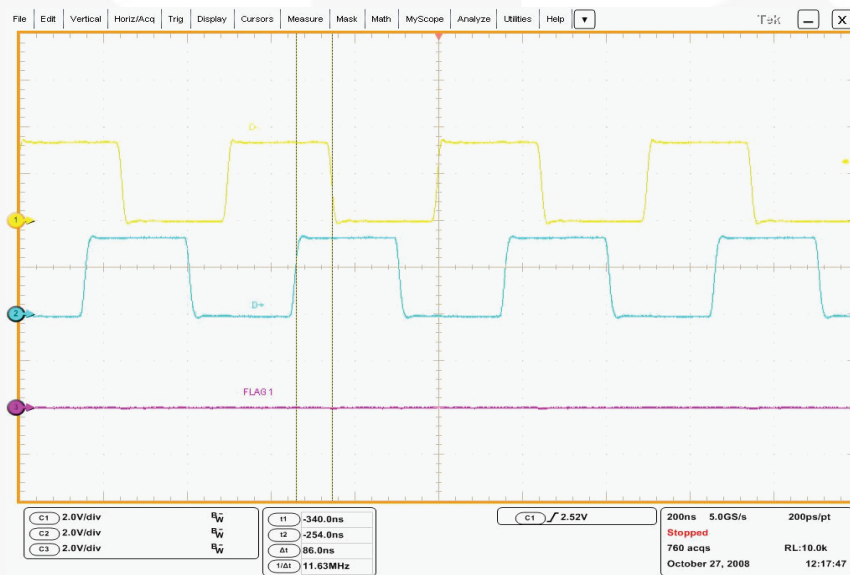

Figure 5. No Fault on Flag 1, Skew=65 ns

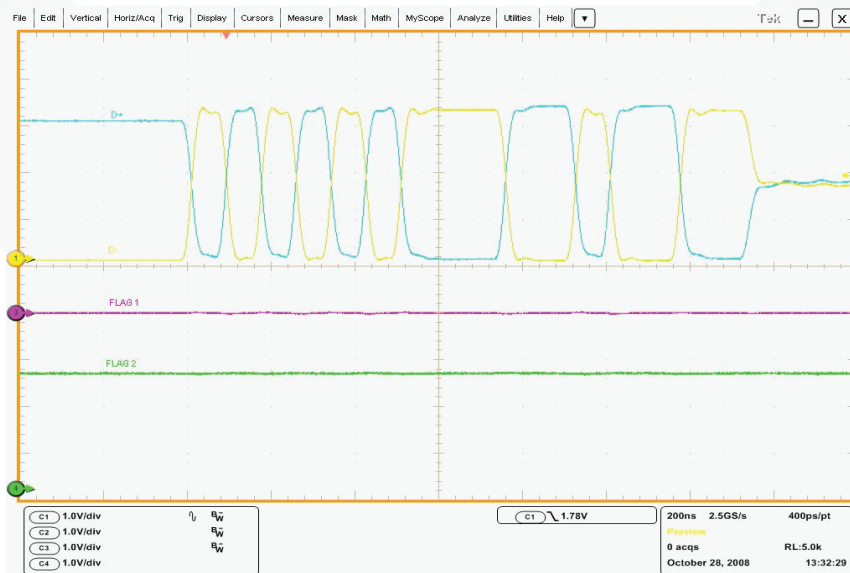

Figure 6. PC Data Running D+/D- (Flag 1 and Flag 2 at Correct Levels)

Application Information

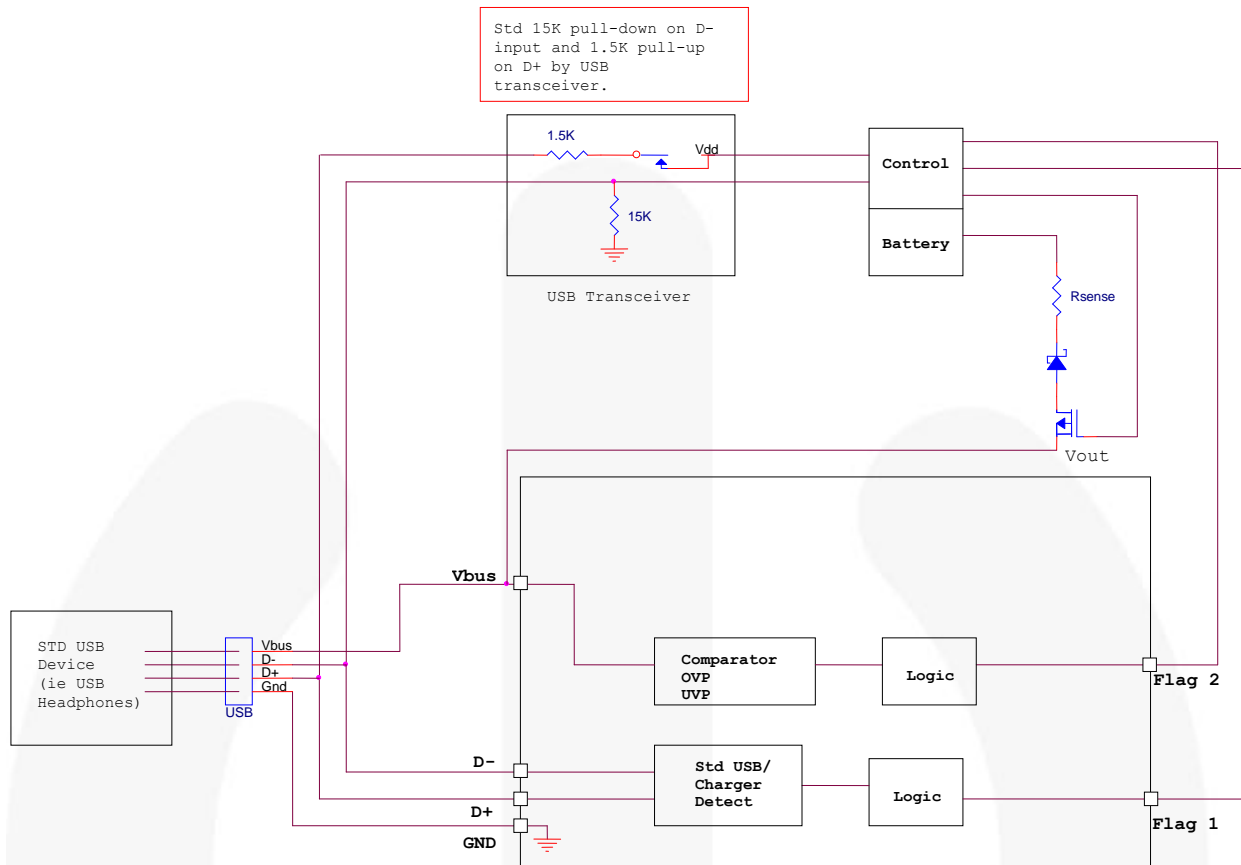

Figure 7. Typical Application System with USB Transceiver

With USB Transceiver (Figure 7)

The FAN3988 sets the FLAG1 pin to logic HIGH or LOW as an indicator to the system controller that a standard USB device or a charger is connected to the USB port. The FAN3988 also monitors the V_{BUS} for over- or under-voltage conditions. The FLAG2 pin is set LOW if V_{BUS} is less than 3.3 V or greater than 6.0 V.

In a standard USB configuration, there is a switch in the USB transceiver that is always ON in the full-speed mode. It is ON during the transition from full-speed mode to high-speed mode and is turned off after enumeration is complete.

In a condition where D+ and D- are shorted when a charger is plugged into the USB port, the USB switch is ON and pulled to V_{DD} , which is about 3.3 V, making both D+ and D- HIGH and flag1 set HIGH – indicating that a charging device is connected to the port.

In a condition where D+ and D- are connected to a standard USB device, the D+ is pulled to V_{DD} and D- is set LOW (due to the 15 k Ω pull-down in the USB transceiver) and flag1 is LOW.

If D+ and D- are open (floating), D+ is pulled to V_{DD} and D- floats LOW, which makes flag1 LOW.

Without USB Transceiver (Figure 8)

The FAN3988 sets the FLAG1 pin to logic HIGH or LOW as an indicator to the system controller that a standard USB device or a charger is connected to the USB port. The FAN3988 also monitors the V_{BUS} for over- or under-voltage conditions. The FLAG2 pin is set LOW if V_{BUS} is less than 3.3 V or greater than 6.0 V.

In a condition where a USB transceiver is not incorporated or there is a switch between the USB port and the FAN3988, external resistors must be used to set the correct input logic states on the D+ D- inputs. A 5 M Ω pull-down on the D- line and a 1 M Ω pull-up on the D+ line are recommended.

When a condition exists where a charger is plugged into the USB port (D+ D- shorted), the voltage divider of 1 M Ω and 5 M Ω puts a voltage of 2.75 V on the D+ D- inputs and flag1 is HIGH, indicating a charger is connected to port.

In a condition where the USB port is connected to a standard USB device, the D+ input is pulled up to V_{DD} (system supply) in parallel with the 1.5 k Ω on a USB transceiver with a parallel R value of 1.497 k Ω . The D- input is connected to a 15 k Ω pull-down by the USB device and in parallel with 5 M Ω with a parallel R value of 14.955 k Ω . This condition makes flag1 LOW.

If D+ and D- are open (floating), D+ is pulled to V_{DD} (system supply) and D- floats LOW, which makes flag1 LOW.

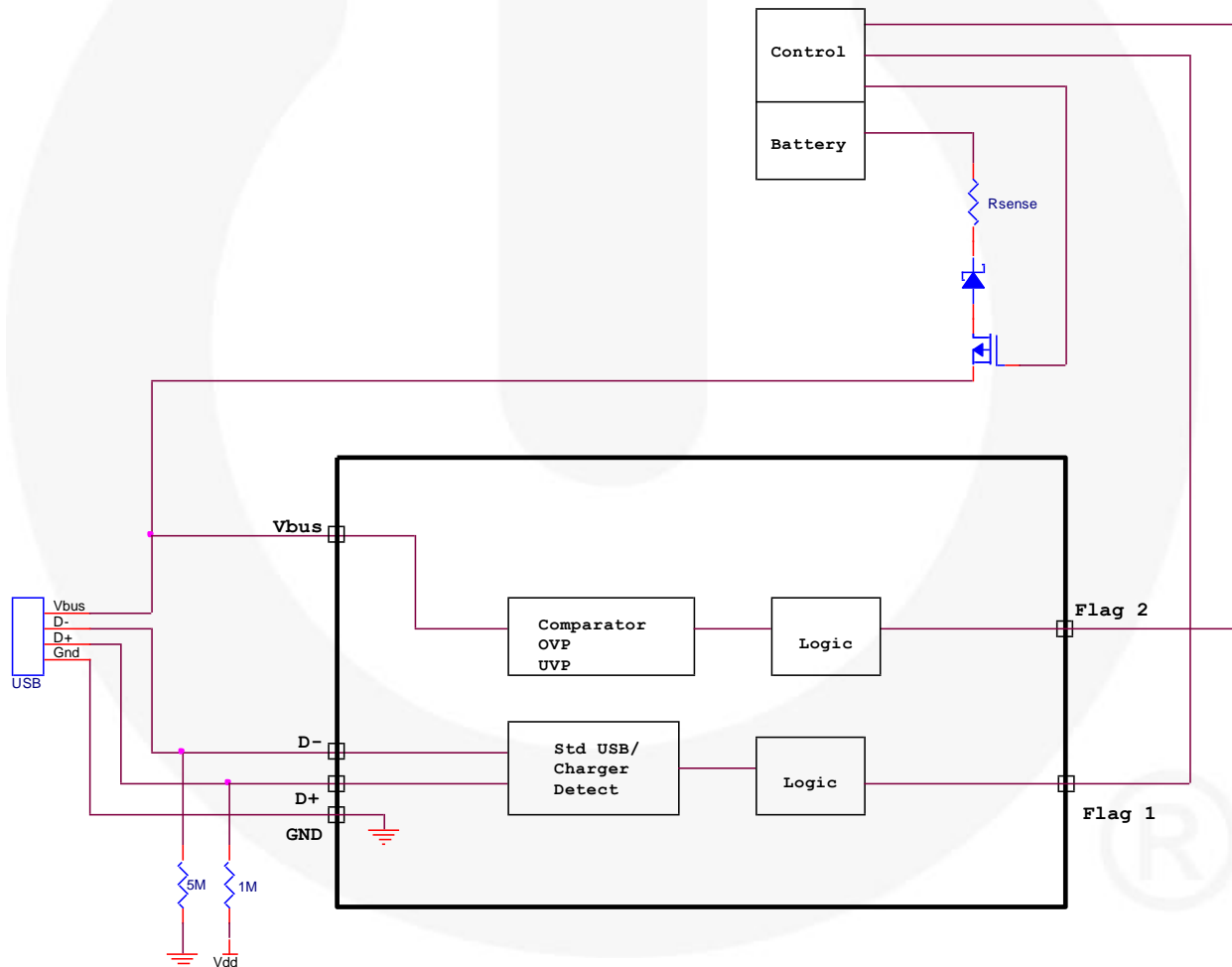
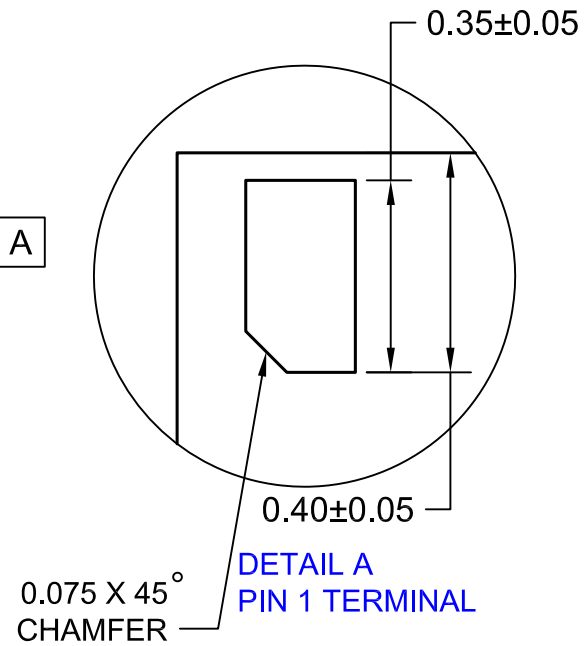
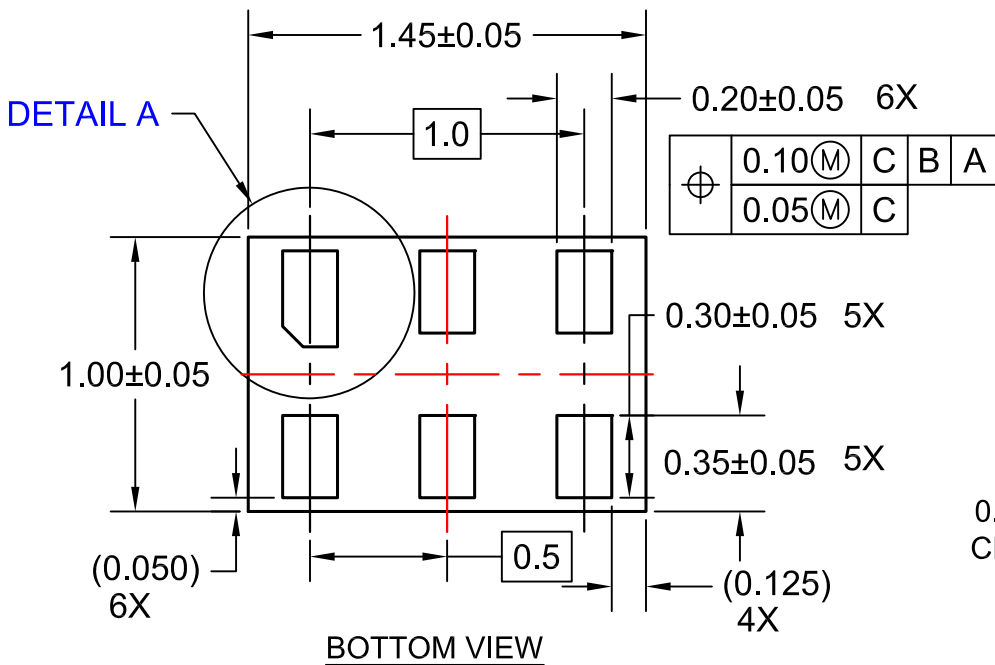
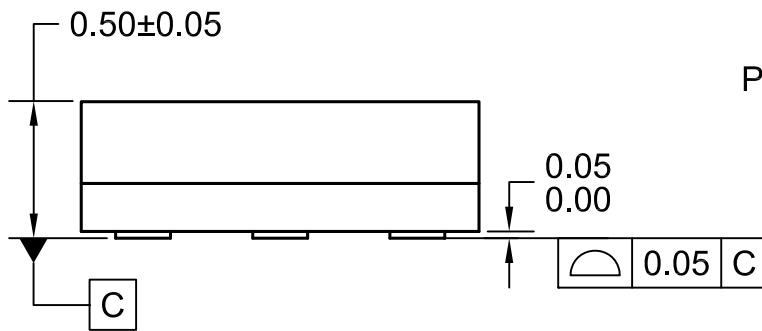
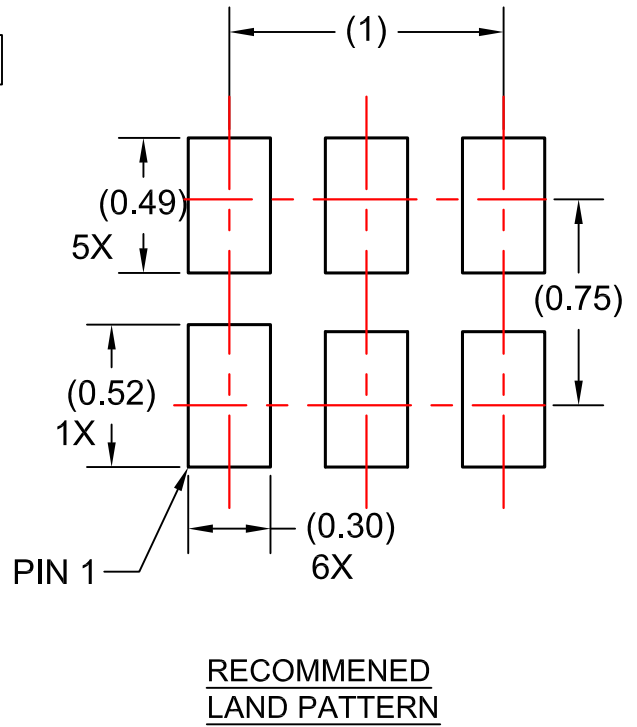
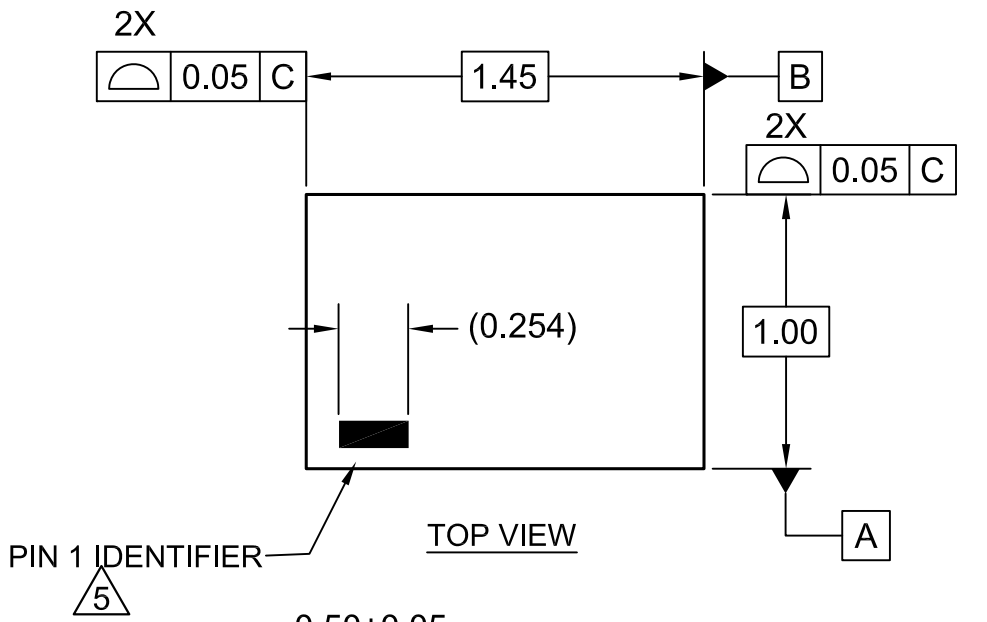

Figure 8. Typical System Application without USB Transceiver



NOTES:

1. CONFORMS TO JEDEC STANDARD MO-252 VARIATION UAAD
2. DIMENSIONS ARE IN MILLIMETERS
3. DRAWING CONFORMS TO ASME Y14.5M-2009
4. LANDPATTERN RECOMMENDATION PER FSC
5. PIN ONE IDENTIFIER IS 2X LENGTH OF ANY OTHER LINE IN THE MARK CODE LAYOUT.
6. FILENAME AND REVISION: MAC06AREV6



ON Semiconductor and  are trademarks of Semiconductor Components Industries, LLC dba ON Semiconductor or its subsidiaries in the United States and/or other countries. ON Semiconductor owns the rights to a number of patents, trademarks, copyrights, trade secrets, and other intellectual property. A listing of ON Semiconductor's product/patent coverage may be accessed at www.onsemi.com/site/pdf/Patent-Marking.pdf. ON Semiconductor reserves the right to make changes without further notice to any products herein. ON Semiconductor makes no warranty, representation or guarantee regarding the suitability of its products for any particular purpose, nor does ON Semiconductor assume any liability arising out of the application or use of any product or circuit, and specifically disclaims any and all liability, including without limitation special, consequential or incidental damages. Buyer is responsible for its products and applications using ON Semiconductor products, including compliance with all laws, regulations and safety requirements or standards, regardless of any support or applications information provided by ON Semiconductor. "Typical" parameters which may be provided in ON Semiconductor data sheets and/or specifications can and do vary in different applications and actual performance may vary over time. All operating parameters, including "Typicals" must be validated for each customer application by customer's technical experts. ON Semiconductor does not convey any license under its patent rights nor the rights of others. ON Semiconductor products are not designed, intended, or authorized for use as a critical component in life support systems or any FDA Class 3 medical devices or medical devices with a same or similar classification in a foreign jurisdiction or any devices intended for implantation in the human body. Should Buyer purchase or use ON Semiconductor products for any such unintended or unauthorized application, Buyer shall indemnify and hold ON Semiconductor and its officers, employees, subsidiaries, affiliates, and distributors harmless against all claims, costs, damages, and expenses, and reasonable attorney fees arising out of, directly or indirectly, any claim of personal injury or death associated with such unintended or unauthorized use, even if such claim alleges that ON Semiconductor was negligent regarding the design or manufacture of the part. ON Semiconductor is an Equal Opportunity/Affirmative Action Employer. This literature is subject to all applicable copyright laws and is not for resale in any manner.

PUBLICATION ORDERING INFORMATION

LITERATURE FULFILLMENT:

Literature Distribution Center for ON Semiconductor
19521 E. 32nd Pkwy, Aurora, Colorado 80011 USA
Phone: 303-675-2175 or 800-344-3860 Toll Free USA/Canada
Fax: 303-675-2176 or 800-344-3867 Toll Free USA/Canada
Email: orderlit@onsemi.com

N. American Technical Support: 800-282-9855 Toll Free
USA/Canada
Europe, Middle East and Africa Technical Support:
Phone: 421 33 790 2910
Japan Customer Focus Center
Phone: 81-3-5817-1050

ON Semiconductor Website: www.onsemi.com
Order Literature: <http://www.onsemi.com/orderlit>
For additional information, please contact your local
Sales Representative

Mouser Electronics

Authorized Distributor

Click to View Pricing, Inventory, Delivery & Lifecycle Information:

[ON Semiconductor:](#)

[FAN3988IL6X_F113](#)



Компания «ЭлектроПласт» предлагает заключение долгосрочных отношений при поставках импортных электронных компонентов на взаимовыгодных условиях!

Наши преимущества:

- Оперативные поставки широкого спектра электронных компонентов отечественного и импортного производства напрямую от производителей и с крупнейших мировых складов;
- Поставка более 17-ти миллионов наименований электронных компонентов;
- Поставка сложных, дефицитных, либо снятых с производства позиций;
- Оперативные сроки поставки под заказ (от 5 рабочих дней);
- Экспресс доставка в любую точку России;
- Техническая поддержка проекта, помощь в подборе аналогов, поставка прототипов;
- Система менеджмента качества сертифицирована по Международному стандарту ISO 9001;
- Лицензия ФСБ на осуществление работ с использованием сведений, составляющих государственную тайну;
- Поставка специализированных компонентов (Xilinx, Altera, Analog Devices, Intersil, Interpoint, Microsemi, Aeroflex, Peregrine, Syfer, Eurofarad, Texas Instrument, Miteq, Cobham, E2V, MA-COM, Hittite, Mini-Circuits, General Dynamics и др.);

Помимо этого, одним из направлений компании «ЭлектроПласт» является направление «Источники питания». Мы предлагаем Вам помощь Конструкторского отдела:

- Подбор оптимального решения, техническое обоснование при выборе компонента;
- Подбор аналогов;
- Консультации по применению компонента;
- Поставка образцов и прототипов;
- Техническая поддержка проекта;
- Защита от снятия компонента с производства.



Как с нами связаться

Телефон: 8 (812) 309 58 32 (многоканальный)

Факс: 8 (812) 320-02-42

Электронная почта: org@eplast1.ru

Адрес: 198099, г. Санкт-Петербург, ул. Калинина, дом 2, корпус 4, литера А.