

M SERIES CONNECTORS RATCHET COUPLING

M SERIES

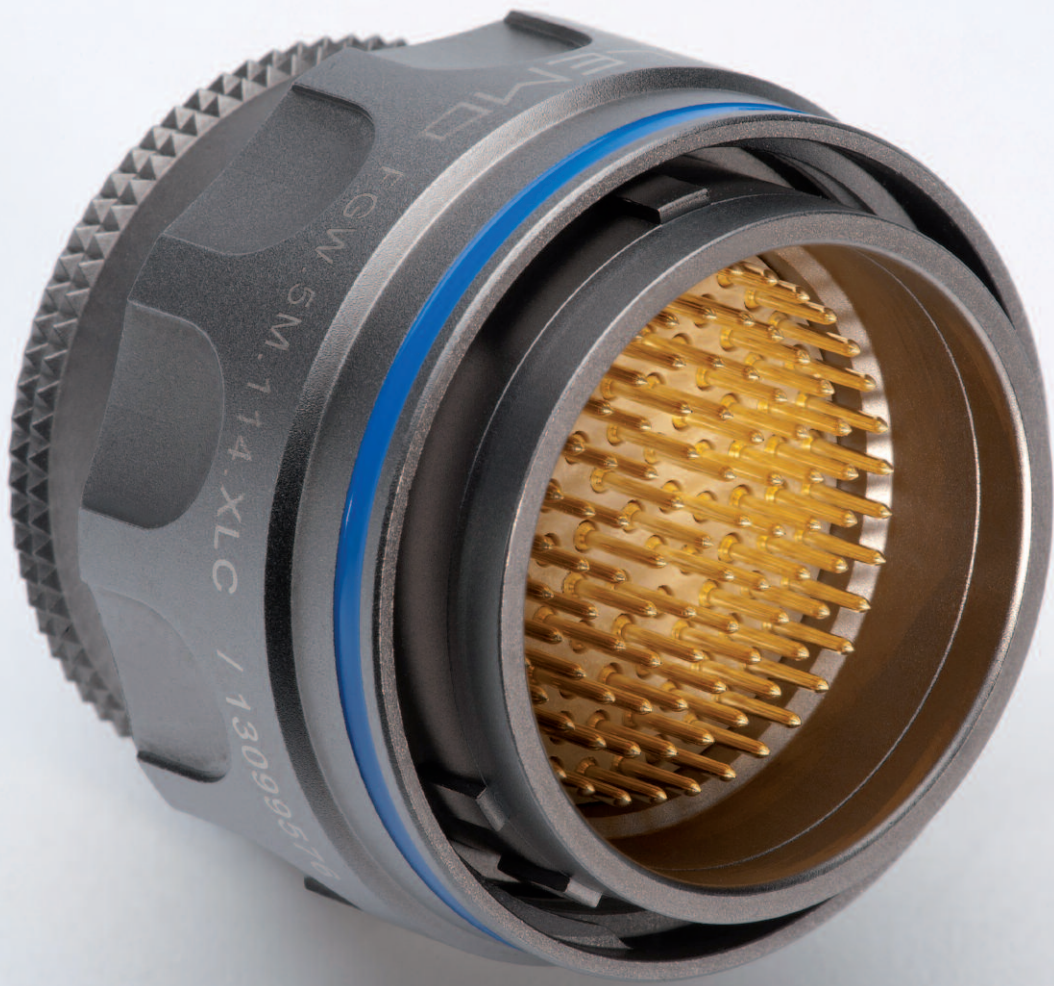

 **LEMO**



Introduction

This catalogue gives the complete description of LEMO M series connectors. M series connectors are lightweight triple-start ratchet coupling type connectors designed for avionics, aerospace, military, security, motorsport and heavy duty applications.

The LEMO manufacturing programme has been extended to almost 40 series divided into 7 product families with specific mating and environmental characteristics. Each series includes a wide variety of plug, socket and coupler models, available in contact configurations adapted to all round cables. Watertight models are also available. Since LEMO connectors are perfectly screened and designed to guarantee very low resistance to shell electrical continuity, they are particularly adapted to applications where electromagnetic compatibility (EMC) is important.

Technical Characteristics

Materials and Treatments

Component	Shell material code		Material (Standard)	Surface treatment (µm)							Notes	
	X	C		chrome			nickel		gold			
				Cu	Ni	Cr	Cu	Ni	Cu	Ni		Au
Outer shell			Brass (UNS C 38500)	0.5	3	0.3	-	-	-	-	-	
			Aluminium alloy (AA 6262A or AA 6023)	-	-	-	-	5	-	-	-	1)
Conical nut			Brass (UNS C 38500)	0.5	3	0.3	-	-	-	-	-	
			Aluminium alloy (AA 6262A or AA 6023)	-	-	-	-	5	-	-	-	1)
Earthing crown			Bronze (UNS C 54400) or special brass	-	-	-	-	-	0.5	-	1.5	
Coupling nut			Brass (UNS C 38500)	-	-	-	0.5	3	-	-	-	
			Aluminium alloy (AA 6262A or AA 6023)	-	-	-	0.5	3	-	-	-	
Ratchet			Special PEEK	-								
Hexagonal nut			Brass (UNS C 38500)	-	-	-	0.5	3	-	-	-	
			Aluminium alloy (AA 6262A or AA 6023)	-	-	-	-	5	-	-	-	
Male crimp contact			Brass (UNS C 34500)	-	-	-	-	-	0.5	3	1.0	
Female crimp contact			Bronze (UNS C 54400)	-	-	-	-	-	0.5	3	1.5	
Clips			Cu-Be or special steel	without treatment								
Insulator			PEEK	-								
O-ring			Silicone	-								
			FPM/FKM (Viton®)	-								
Sealing resin			Epoxy (Araldite® or Stycast®)	-								
Cable rear seal			Fluorosilicone	-								
Spring			Stainless steel	-								

Notes: standards for surface treatment are as follows: chrome-plated FS QQ-C-320B; nickel-plated FS QQ-N-290A or MIL DTL 32119; gold-plated ISO 27874.
¹⁾ anthracite colour.

Environmental performance

Characteristics	Value	IEC international	MIL-spec tests
Operating temperature (mated)	- 55° C/+200° C		
Ingress protection index	IP 68 (at 2 m, 15Hr)	IEC 60529	
Fungus	Satisfied - by material analysis		MIL-STD 810F-508.5
Flammability	60 sec. front and back face		EIA-364-104A
Fluid contamination ¹⁾	Fuels, gasoline, hydraulic oils, solvents, de-icing		MIL-STD-810F method 504
Sand and dust ²⁾	6 hr, 55° C, blowing < 150 µm dust		MIL-STD 810F-510.4
Lightning strike	10 K amps - 6 times		EIA-364-75
Altitude-low temp ³⁾	-65° C; 40'000 feet and 400 VAC		EIA-364-105A
Salt fog ⁴⁾	Alum. shell (slight pitting after 48Hr), Brass shell (500Hr)	IEC 60512-6 test 11f	EIA-364-26
Thermal shock	5 cycles: -65° C to +150° C	IEC 60512-11-4	EIA-364-32 test condition IV
Altitude immersion	No moisture on contacts		EIA-364-03
Air leakage ⁵⁾	< 10 ⁻⁷ mbar. l/sec (Helium)	IEC 60512-7 14 b	MIL-STD-1344 method 1008.1
Humidity	21 days at 95%	IEC 60068-2	EIA-364-31 method IV

Note:

- 1) Connectors immersed at both 70°C and 25°C according to specification. Connectors are then inspected, no visual signs of damage seen.
 Fuels: Kerosene, JP4, (Nato F40) at 70°C +/- 2°C. Gasoline: ASTM 4814. Hydraulic oils: Mineral oil based MIL-H-5606.
 Solvents: Isopropanol. De-icing fluids: 25% ethylene glycol.
- 2) No signs of damage, connectors opened and closed without difficulty. Dust or sand was not inside connector.
- 3) Wired mated connectors = no voltage breakdown, shell to all contacts (connected together) w/400 VAC after 1 hour at 65° C at 40'000 feet altitude.
- 4) Corrosion resistance. Inspection: salt deposits shall be removed by gentle wash in running water with light brushing using soft brush.
 Aluminium Shell (material code: X) max: 96 hours. Brass shell (material code: C) over 500 hours.
- 5) Only for vacuumtight model (HE•)

Electrical performance

Characteristics	Value	IEC international	MIL-spec tests
Insulation resist. (at ambient temp.) ⁶⁾	> 10 ¹² Ω, > 10 ¹⁰ Ω (after humidity)	IEC 60512-2 test 3a	EIA-364-21
Dielectric withstanding volt. (sea level)	See table page 16-17	IEC 60512-2 test 4a	EIA-364-20
Contact resistance	See table below ⁷⁾	IEC 60512-2 test 2a	EIA-364-06
Current rating	See insulator configuration page 16-17	IEC 60512-3 test 5a	
Shell to shell conductivity	< 1.5 mΩ	IEC 60512-2-6	EIA-364-83
Shielding effectiveness, low frequency	≥ 80 dB up to 1GHz		EIA-364-66
Shielding effectiveness, high frequency	≥ 70 dB (3GHz), ≥ 58 dB (6GHz), ≥ 40 dB (10GHz)		EIA-364-66

Note: ⁶⁾ After humidity test: 21 days at 95% RH according to IEC 60068-2. Insulation resistance measured between the contacts and contact/shell.

Contact resistance ⁷⁾ IEC 60512-2 test 2a				Value
0.5	0.7	0.9	1.3	∅ A (mm)
≤ 8.7	≤ 6.1	≤ 4.8	≤ 3.6	mΩ

Notes: ⁷⁾ after 5000 mating cycles and the salt spray test according to IEC 60512-6 test 11 f.

Mechanical performance

Characteristics	Value	IEC international	MIL-spec tests
Endurance	3000 cycles	IEC 60512-5 test 9a	EIA-364-09
Gunfire vibration	25 to 2000 Hz, 3 axis (Apache helicopter)		MIL-STD-810F method 519.5
Vibration-Sine ⁸⁾	30 g, 3 axis, 12 hr		MIL-STD-202 method 204-G
Vibration-Random	50-2000 Hz, 37.8 g rms-3 axes; 4h amb	IEC 60512-6-4	EIA-364-28 test cond. V letter I
Shock	300 g - 3 msec	IEC 60512-6-3	EIA-364-27 condition D
Acceleration	50 g acceleration		MIL-STD-1344 - 2011-1, A
Contact retention	> 22 N (∅ 0.7 mm), > 30 N (∅ 0.9 mm)	IEC 60512-8 test 15a	
Torque	See table below		

Note: ⁸⁾ Amplitude: 30G. Frequency: 10 to 2000 Hz. Time per axis: 4 hours (X, Y, Z). No signal discontinuity above 1 μs.

Series	Coupling torque tightning (N.cm)	Coupling torque untightning (N.cm)	Series	Coupling torque tightning (N.cm)	Coupling torque untightning (N.cm)
0M	4	5	TM	26	30
1M	10	11	4M	26	25
2M	20	14	LM	48 ⁹⁾	43
3M	34	29	5M	91 ⁹⁾	54

Note: ⁹⁾ Higher contact density = larger torque force.

M Series

The M Series connector offers a new innovative design for avionics, aerospace, military, security, motorsport and heavy duty applications.

Made of high-strength aluminium, this connector is one of the lightest and most compact of the LEMO product line. A one-grip ratchet screw system enables quick and secure coupling of the connectors. The arctic grip makes it easy to manipulate the connector while wearing gloves or when the connector is located in a difficult to access area.

Features

- Ratchet-coupling mechanism
- Compact design for space savings
- Oil and fuel resistant
- 360° screening for full EMC shielding
- Colour coding / keying
- Scoop proof
- Threaded for MIL-DTL-38999L backshell
- Quick mating: less than 3/4 turn to seat
- Lightweight
- High vibration and shock resistance
- Sealed to IP68 when mated
- Reverse sex configuration
- Pin configuration from 2 to 114 contacts

Metal housing models (page 5)

Straight plugs

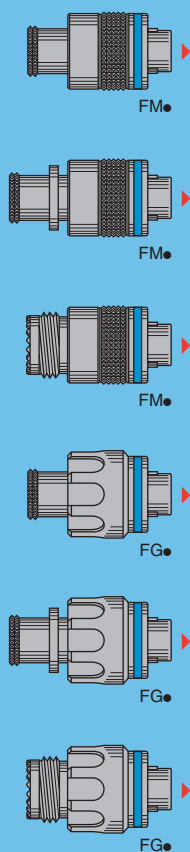

Fixed sockets

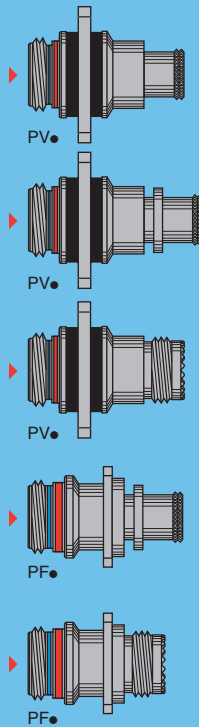
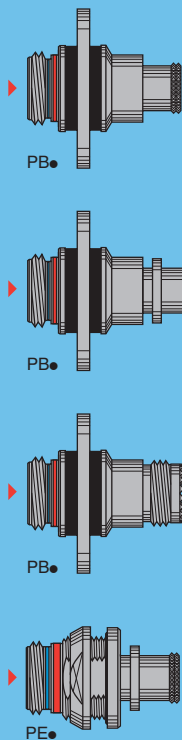
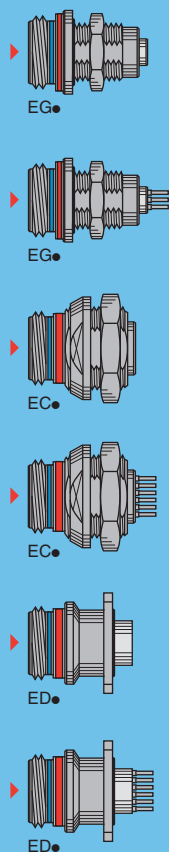

Free sockets

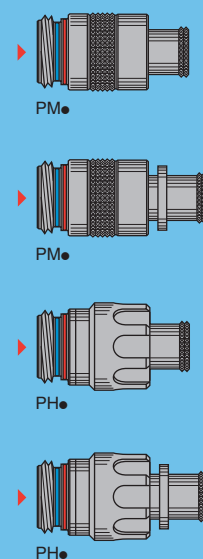

USB models

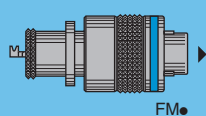

Straight plugs

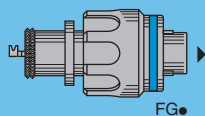

Fixed sockets

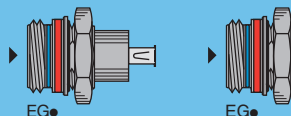

Watertight model (unmated)

Fixed socket

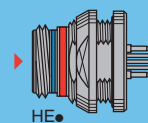

Part Numbering System

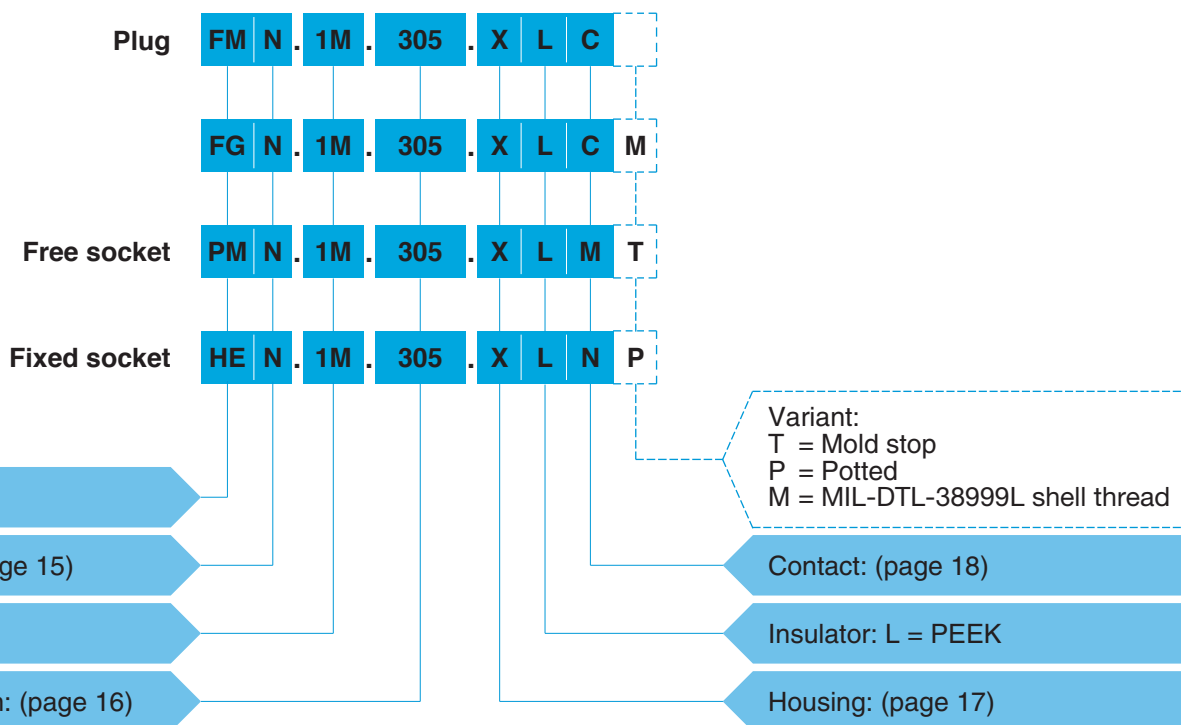

Part Number Example

Straight plug:

FMN.1M.305.XLC = straight plug with key (N), 1M series, multipole type with 5 contacts, outer shell in anthracite nickel-plated aluminium alloy, PEEK insulator, male crimp contacts.

Straight plug:

FGN.1M.305.XLCM = straight plug with key (N), arctic grip, 1M series, multipole type with 5 contacts, outer shell in anthracite nickel-plated aluminium alloy, PEEK insulator, male crimp contacts and with MIL-DTL-38999L thread for additional backshell (not supplied).

Free socket:

PMN.1M.305.XLMT = free socket with key (N), 1M series, multipole type with 5 contacts, outer shell in anthracite nickel-plated aluminium alloy, PEEK insulator, female crimp contacts and mold stop.

Fixed socket:

HEN.1M.305.XLNP = fixed socket, nut fixing, with key (N), 1M series, multipole type with 5 contacts, outer shell in anthracite nickel-plated aluminium alloy, PEEK insulator, female print contacts, watertight.

Part Section Showing Internal Components

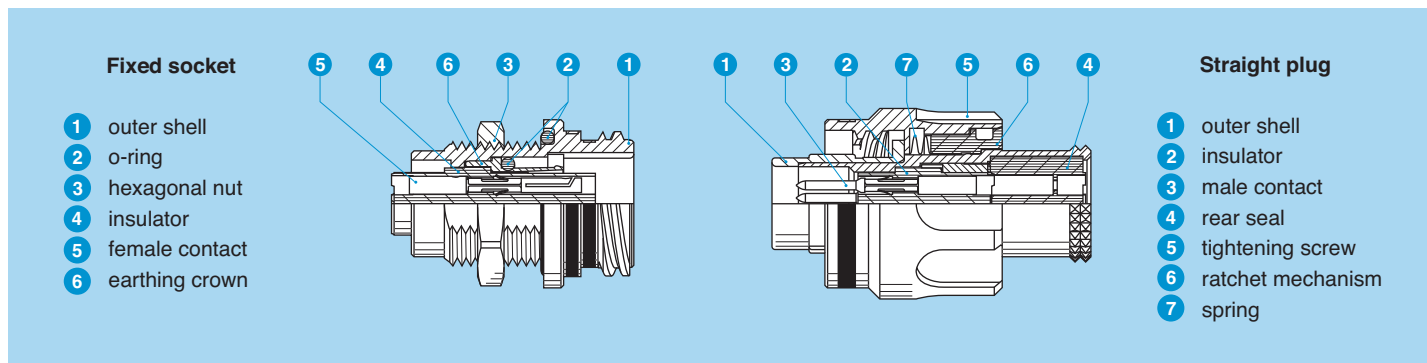



Metal housing models



FM● Straight plug, key (N) or keys (P, R, S, T, U, V, W and X) with knurled grip

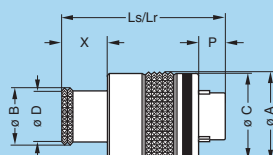

Reference		Dimensions (mm)							
Model	Series	A	B	C	D	Ls	Lr	P	X
FM●	0M	13.1	8.8	12.7	8.0	24.1	24.1	3.9	6.7
FM●	1M	14.6	10.5	14.2	9.7	24.1	24.1	3.9	6.7
FM●	2M	17.6	14.0	17.2	13.0	24.5	24.5	3.9	7.1
FM●	3M	19.6	16.0	19.2	15.0	24.5	24.5	3.9	7.1
FM●	TM	22.5	17.9	22.0	16.7	28.6	28.6	3.4	7.6
FM●	4M	25.0	20.7	24.5	19.5	28.6	28.6	3.4	7.6
FM●	LM	28.5	23.9	28.0	22.7	28.6	28.6	3.4	7.6
FM●	5M	34.0	29.7	33.5	28.5	28.6	28.6	3.4	7.6

Part number example: FMN.1M.305.XLC

Note: Ls = standard gender, Lr = reverse gender



FM● Straight plug, key (N) or keys (P, R, S, T, U, V, W and X) with knurled grip and mold stop

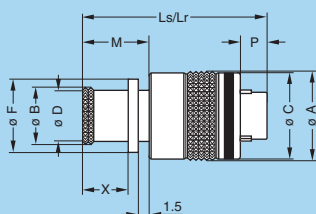

Reference		Dimensions (mm)									
Model	Series	A	B	C	D	F	Ls	Lr	M	P	X
FM●	0M	13.1	8.8	12.7	8.0	10.7	27.1	27.1	9.7	3.9	6.7
FM●	1M	14.6	10.5	14.2	9.7	12.4	27.1	27.1	9.7	3.9	6.7
FM●	2M	17.6	14.0	17.2	13.0	15.5	27.5	27.5	10.1	3.9	7.1
FM●	3M	19.6	16.0	19.2	15.0	17.5	27.5	27.5	10.1	3.9	7.1
FM●	TM	22.5	17.9	22.0	16.7	19.8	31.6	31.6	10.6	3.4	7.6
FM●	4M	25.0	20.7	24.5	19.5	22.6	31.6	31.6	10.6	3.4	7.6
FM●	LM	28.5	23.9	28.0	22.7	25.8	31.6	31.6	10.6	3.4	7.6
FM●	5M	34.0	29.7	33.5	28.5	31.4	31.6	31.6	10.6	3.4	7.6

Part number example: FMN.1M.305.XLCT

Note: Ls = standard gender, Lr = reverse gender



FM● Straight plug, key (N) or keys (P, R, S, T, U, V, W and X) with knurled grip and MIL-DTL-38999L shell thread

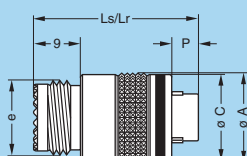

Reference		Dimensions (mm)						
Model	Series	A	C	e	Ls	Lr	P	Code ¹⁾
FM●	1M	14.6	14.2	M12x1.0	26.4	26.4	3.9	A
FM●	2M	17.6	17.2	M15x1.0	26.4	26.4	3.9	B
FM●	3M	19.6	19.2	M18x1.0	26.4	26.4	3.9	C
FM●	TM	22.5	22.0	M18x1.0	30.0	30.0	3.4	C
FM●	4M	25.0	24.5	M22x1.0	30.0	30.0	3.4	D
FM●	LM	28.5	28.0	M25x1.0	30.0	30.0	3.4	E
FM●	5M	34.0	33.5	M31x1.0	30.0	30.0	3.4	G

Part number example: FMN.1M.305.XLCM

Note: Ls = standard gender, Lr = reverse gender. ¹⁾ MIL-DTL-38999L shell size code (backshell not supplied)

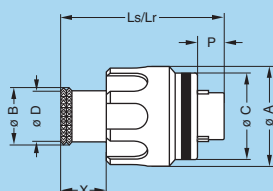

FG● Straight plug, key (N) or keys (P, R, S, T, U, V, W and X) with arctic grip

Reference		Dimensions (mm)							
Model	Series	A	B	C	D	Ls	Lr	P	X
FG●	0M	14.4	8.8	12.7	8.0	24.1	24.1	3.9	6.7
FG●	1M	15.9	10.5	14.2	9.7	24.1	24.1	3.9	6.7
FG●	2M	18.9	14.0	17.2	13.0	24.5	24.5	3.9	7.1
FG●	3M	20.9	16.0	19.2	15.0	24.5	24.5	3.9	7.1
FG●	TM	23.4	17.9	22.0	16.7	28.6	28.6	3.4	7.6
FG●	4M	25.9	20.7	24.5	19.5	28.6	28.6	3.4	7.6
FG●	LM	29.4	23.9	28.0	22.7	28.6	28.6	3.4	7.6
FG●	5M	34.9	29.7	33.5	28.5	28.6	28.6	3.4	7.6

Part number example: FGN.1M.305.XLC

Note: Ls = standard gender, Lr = reverse gender

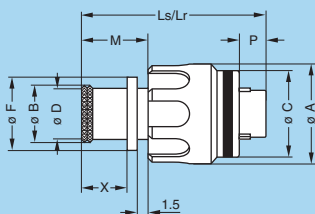

FG● Straight plug, key (N) or keys (P, R, S, T, U, V, W and X) with arctic grip and mold stop

Reference		Dimensions (mm)									
Model	Series	A	B	C	D	F	Ls	Lr	M	P	X
FG●	0M	14.4	8.8	12.7	8.0	10.7	27.1	27.1	9.7	3.9	6.7
FG●	1M	15.9	10.5	14.2	9.7	12.4	27.1	27.1	9.7	3.9	6.7
FG●	2M	18.9	14.0	17.2	13.0	15.5	27.5	27.5	10.1	3.9	7.1
FG●	3M	20.9	16.0	19.2	15.0	17.5	27.5	27.5	10.1	3.9	7.1
FG●	TM	23.4	17.9	22.0	16.7	19.8	31.6	31.6	10.6	3.4	7.6
FG●	4M	25.9	20.7	24.5	19.5	22.6	31.6	31.6	10.6	3.4	7.6
FG●	LM	29.4	23.9	28.0	22.7	25.8	31.6	31.6	10.6	3.4	7.6
FG●	5M	34.9	29.7	33.5	28.5	31.4	31.6	31.6	10.6	3.4	7.6

Part number example: FGN.1M.305.XLCT

Note: Ls = standard gender, Lr = reverse gender

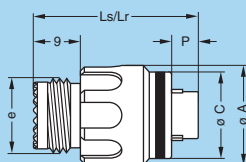

FG● Straight plug, key (N) or keys (P, R, S, T, U, V, W and X) with arctic grip and MIL-DTL-38999L shell thread

Reference		Dimensions (mm)						
Model	Series	A	C	e	Ls	Lr	P	Code ¹⁾
FG●	1M	15.9	14.2	M12x1.0	26.4	26.4	3.9	A
FG●	2M	18.9	17.2	M15x1.0	26.4	26.4	3.9	B
FG●	3M	20.9	19.2	M18x1.0	26.4	26.4	3.9	C
FG●	TM	23.4	22.0	M18x1.0	30.0	30.0	3.4	C
FG●	4M	25.9	24.5	M22x1.0	30.0	30.0	3.4	D
FG●	LM	29.4	28.0	M25x1.0	30.0	30.0	3.4	E
FG●	5M	34.9	33.5	M31x1.0	30.0	30.0	3.4	G

Part number example: FGN.1M.305.XLCM

Note: Ls = standard gender, Lr = reverse gender. ¹⁾ MIL-DTL-38999L shell size code (backshell not supplied)

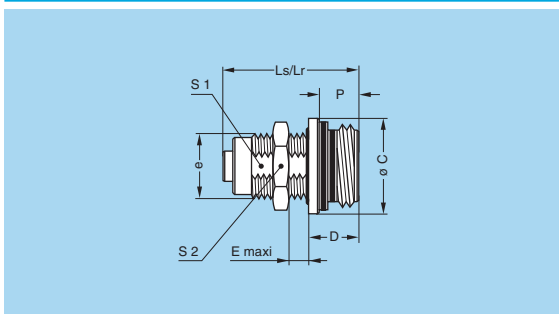

EG● Fixed socket, nut fixing, key (N) or keys (P, R, S, T, U, V, W and X)

Reference		Dimensions (mm)								
Model	Series	C	D	e	E	Ls	Lr	P	S1	S2
EG●	0M	12.7	6.8	M9x0.6	5.0	18.1	18.1	5.3	8.2	11.0
EG●	1M	14.2	6.8	M11x1.0	4.5	18.1	18.1	5.3	9.5	13.0
EG●	2M	17.2	6.8	M14x1.0	4.5	18.1	18.1	5.3	12.5	17.0
EG●	3M	19.2	6.8	M16x1.0	4.0	18.1	18.1	5.3	14.5	19.0
EG●	TM	22.0	9.4	M18x1.0	4.0	19.8	21.7	7.9	16.5	22.0
EG●	4M	24.5	9.4	M21x1.0	4.0	19.8	21.7	7.9	19.5	25.0
EG●	LM	28.0	9.4	M24x1.0	4.0	19.8	21.7	7.9	22.5	30.0
EG●	5M	33.5	9.4	M30x1.0	4.0	19.8	21.7	7.9	28.5	36.0

Part number example: EGN.1M.305.XLM

Panel cut-out (page 23).

Note: Ls = standard gender, Lr = reverse gender

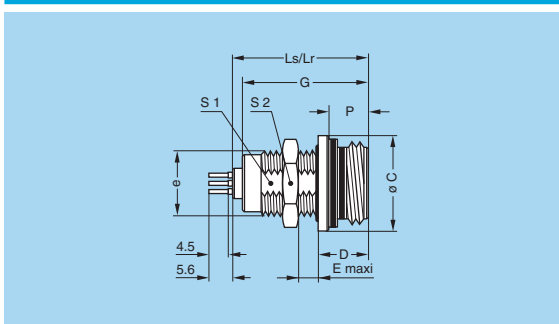

EG● Fixed socket, nut fixing, key (N) or keys (P, R, S, T, U, V, W and X) for printed circuit

Reference		Dimensions (mm)									
Model	Series	C	D	e	E	G	Ls	Lr	P	S1	S2
EG●	0M	12.7	6.8	M9x0.6	5.0	16.8	18.1	18.1	5.3	8.2	11.0
EG●	1M	14.2	6.8	M11x1.0	4.5	16.8	18.1	18.1	5.3	9.5	13.0
EG●	2M	17.2	6.8	M14x1.0	4.5	16.8	18.1	18.1	5.3	12.5	17.0
EG●	3M	19.2	6.8	M16x1.0	4.0	16.8	18.1	18.1	5.3	14.5	19.0
EG●	TM	22.0	9.4	M18x1.0	4.0	18.9	19.8	21.7	7.9	16.5	22.0
EG●	4M	24.5	9.4	M21x1.0	4.0	18.9	19.8	21.7	7.9	19.5	25.0
EG●	LM	28.0	9.4	M24x1.0	4.0	18.9	19.8	21.7	7.9	22.5	30.0
EG●	5M	33.5	9.4	M30x1.0	4.0	18.9	19.8	21.7	7.9	28.5	36.0

Part number example: EGN.1M.305.XLN

Panel cut-out (page 23). PCB drilling pattern (page 24).

Note: Ls = standard gender, Lr = reverse gender

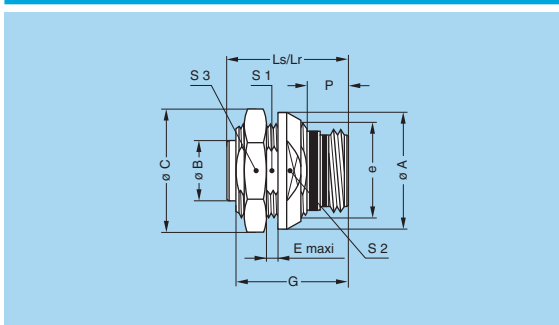

EC● Fixed socket with two nuts, key (N) or keys (P, R, S, T, U, V, W and X)

Reference		Dimensions (mm)											
Model	Series	A	B	C	E	e	G	Ls	Lr	P	S1	S2	S3
EC●	0M	17	4.72	18.2	5.0	M13x0.75	16.8	18.1	18.1	5.3	11.5	14.0	16.0
EC●	1M	18	5.95	19.2	5.0	M14x1.00	16.8	18.1	18.1	5.3	12.5	16.0	17.0
EC●	2M	21	8.95	21.5	4.0	M17x1.00	16.8	18.1	18.1	5.3	15.5	18.0	19.0
EC●	3M	23	10.95	25.0	4.0	M19x1.00	16.8	18.1	18.1	5.3	17.5	20.0	22.0
EC●	TM	27	12.30	28.0	2.5	M22x1.00	18.9	19.8	21.7	7.9	20.5	23.0	25.0
EC●	4M	29	13.95	34.0	2.5	M24x1.00	18.9	19.8	21.7	7.9	22.5	25.0	30.0
EC●	LM	33	17.95	36.0	2.5	M28x1.00	18.9	19.8	21.7	7.9	26.5	29.0	32.0
EC●	5M	38	22.90	41.0	2.5	M33x1.00	18.9	19.8	21.7	7.9	31.5	34.0	37.0

Part number example: ECN.1M.305.XLM

Panel cut-out (page 23).

Note: Ls = standard gender, Lr = reverse gender. This model is not IP68 (no panel sealing).

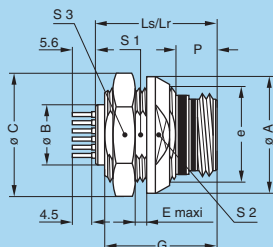

EC● Fixed socket with two nuts, key (N) or keys (P, R, S, T, U, V, W and X) for printed circuit

Reference		Dimensions (mm)											
Model	Series	A	B	C	E	e	G	Ls	Lr	P	S1	S2	S3
EC●	0M	17	4.72	18.2	5.0	M13x0.75	16.8	18.1	18.1	5.3	11.5	14.0	16.0
EC●	1M	18	5.95	19.2	5.0	M14x1.00	16.8	18.1	18.1	5.3	12.5	16.0	17.0
EC●	2M	21	8.95	21.5	4.0	M17x1.00	16.8	18.1	18.1	5.3	15.5	18.0	19.0
EC●	3M	23	10.95	25.0	4.0	M19x1.00	16.8	18.1	18.1	5.3	17.5	20.0	22.0
EC●	TM	27	12.30	28.0	2.5	M22x1.00	18.9	19.8	21.7	7.9	20.5	23.0	25.0
EC●	4M	29	13.95	34.0	2.5	M24x1.00	18.9	19.8	21.7	7.9	22.5	25.0	30.0
EC●	LM	33	17.95	36.0	2.5	M28x1.00	18.9	19.8	21.7	7.9	26.5	29.0	32.0
EC●	5M	38	22.90	41.0	2.5	M33x1.00	18.9	19.8	21.7	7.9	31.5	34.0	37.0

Part number example: ECN.1M.305.XLN

Panel cut-out (page 23). PCB drilling pattern (page 24).

Note: Ls = standard gender, Lr = reverse gender

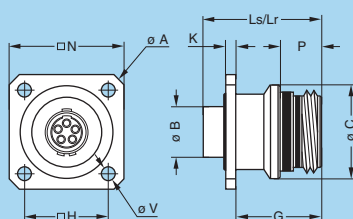
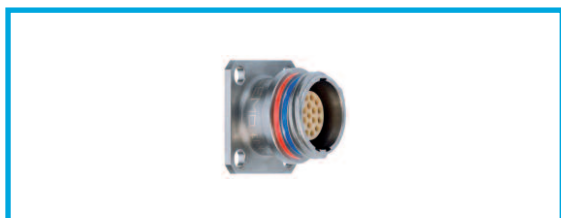

ED● Fixed socket with square flange, key (N) or keys (P, R, S, T, U, V, W and X)

Reference		Dimensions (mm)										
Model	Series	A	B	C	G	H	K	Ls	Lr	N	P	V
ED●	0M	20.6	4.72	12.7	12.8	11.0	1.5	18.1	18.1	16.0	5.3	2.7
ED●	1M	23.8	5.95	14.2	12.8	12.9	1.5	18.1	18.1	18.4	5.3	3.3
ED●	2M	26.9	8.95	17.2	12.8	15.1	1.5	18.1	18.1	20.6	5.3	3.3
ED●	3M	29.0	10.95	19.2	12.8	16.6	1.5	18.1	18.1	22.1	5.3	3.3
ED●	TM	31.4	12.30	22.0	14.5	18.3	2.0	19.8	21.7	23.8	7.9	3.3
ED●	4M	34.6	13.95	24.5	14.5	20.6	2.0	19.8	21.7	26.1	7.9	3.3
ED●	LM	38.0	17.95	28.0	14.5	23.0	2.0	19.8	21.7	28.5	7.9	3.3
ED●	5M	43.7	22.90	33.5	14.5	27.0	2.0	19.8	21.7	32.5	7.9	3.3

Part number example: EDN.1M.305.XLM

Panel cut-out (page 23).

Note: Ls = standard gender, Lr = reverse gender

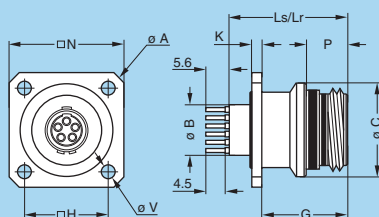

ED● Fixed socket with square flange, key (N) or keys (P, R, S, T, U, V, W and X) for printed circuit

Reference		Dimensions (mm)										
Model	Series	A	B	C	G	H	K	Ls	Lr	N	P	V
ED●	0M	20.6	4.72	12.7	12.8	11.0	1.5	18.1	18.1	16.0	5.3	2.7
ED●	1M	23.8	5.95	14.2	12.8	12.9	1.5	18.1	18.1	18.4	5.3	3.3
ED●	2M	26.9	8.95	17.2	12.8	15.1	1.5	18.1	18.1	20.6	5.3	3.3
ED●	3M	29.0	10.95	19.2	12.8	16.6	1.5	18.1	18.1	22.1	5.3	3.3
ED●	TM	31.4	12.30	22.0	14.5	18.3	2.0	19.8	21.7	23.8	7.9	3.3
ED●	4M	34.6	13.95	24.5	14.5	20.6	2.0	19.8	21.7	26.1	7.9	3.3
ED●	LM	38.0	17.95	28.0	14.5	23.0	2.0	19.8	21.7	28.5	7.9	3.3
ED●	5M	43.7	22.90	33.5	14.5	27.0	2.0	19.8	21.7	32.5	7.9	3.3

Part number example: EDN.1M.305.XLN

Panel cut-out (page 23). PCB drilling pattern (page 24).

Note: Ls = standard gender, Lr = reverse gender

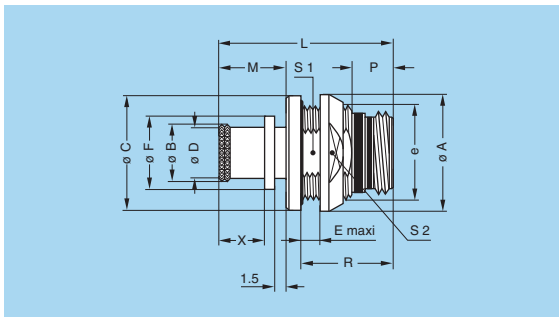

PE● Fixed socket, nut fixing, key (N) or keys (P, R, S, T, U, V, W and X) with mold stop (back panel mounting)

Reference		Dimensions (mm)												
Model	Series	A	B	C	D	E	e	Ls	Lr	M	P	R	S1	S2
PE●	0M	17	8.8	16.8	8.0	5.0	M13x0.75	25.6	25.6	9.7	5.3	13.8	11.5	14
PE●	1M	18	10.5	17.8	9.7	5.0	M14x1.00	25.6	25.6	9.7	5.3	13.8	12.5	16
PE●	2M	21	14.0	20.8	13.0	5.0	M17x1.00	26.0	26.0	10.1	5.3	13.8	15.5	18
PE●	3M	23	16.0	22.8	15.0	5.0	M19x1.00	26.0	26.0	10.1	5.3	13.8	17.5	20
PE●	TM	27	17.9	25.8	16.7	4.0	M22x1.00	29.5	30.1	10.6	7.9	16.9	20.5	23
PE●	4M	29	20.7	27.8	19.5	4.0	M24x1.00	29.5	30.1	10.6	7.9	16.9	22.5	25
PE●	LM	33	23.9	31.8	22.7	4.0	M28x1.00	29.5	30.1	10.6	7.9	16.9	26.5	29
PE●	5M	38	29.7	36.8	28.5	4.0	M33x1.00	29.5	30.1	10.6	7.9	16.9	31.5	34

Part number example: PEN.1M.305.XLMT

Panel cut-out (page 23).

Note: this model is only available with mold stop. The dimensions «F» and «X» are the same as the PB● models. Ls = standard gender, Lr = reverse gender.

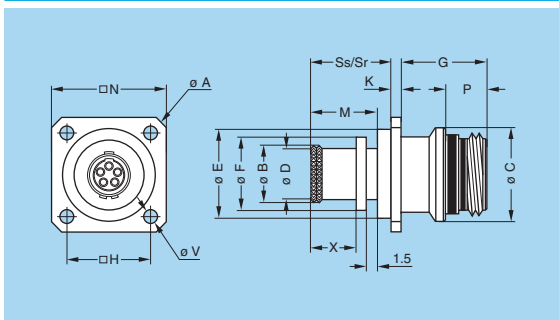

PF● Fixed socket with square flange, key (N) or keys (P, R, S, T, U, V, W and X) with mold stop

Reference		Dimensions (mm)												
Model	Series	A	B	C	D	E	F	G	H	K	N	Ss	Sr	V
PF●	0M	20.6	8.8	12.7	8.0	10.7	10.7	12.8	11.0	1.5	16.0	11.3	11.3	2.7
PF●	1M	23.8	10.5	14.2	9.7	12.4	12.4	12.8	12.9	1.5	18.4	11.3	11.3	3.3
PF●	2M	26.9	14.0	17.2	13.0	15.5	15.5	12.8	15.1	1.5	20.6	11.7	11.7	3.3
PF●	3M	29.0	16.0	19.2	15.0	17.5	17.5	12.8	16.6	1.5	22.1	11.7	11.7	3.3
PF●	TM	31.4	17.9	22.0	16.7	19.8	19.8	14.5	18.3	2.0	23.8	13.0	13.6	3.3
PF●	4M	34.6	20.7	24.5	19.5	22.6	22.6	14.5	20.6	2.0	26.1	13.0	13.6	3.3
PF●	LM	38.0	23.9	28.0	22.7	25.8	25.8	14.5	23.0	2.0	28.5	13.0	13.6	3.3
PF●	5M	47.0	29.7	33.5	28.5	33.0	31.4	14.5	29.4	2.0	37.0	13.0	13.6	3.3

Part number example: PFN.1M.305.XLMT

Panel cut-out (page 23).

Note: this model is only available with mold stop. The dimensions «M», «P» and «X» are the same as the PB● models. Ss = standard gender, Sr = reverse gender.

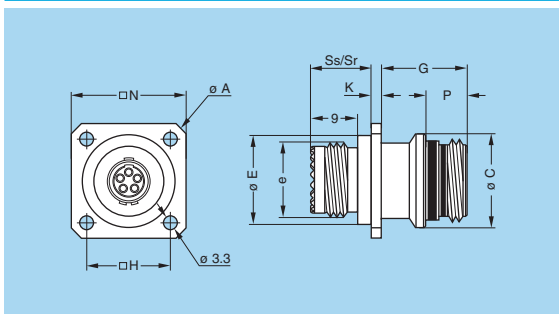

PF● Fixed socket with square flange, key (N) or keys (P, R, S, T, U, V, W and X) with MIL-DTL-38999L shell thread

Reference		Dimensions (mm)										
Model	Series	A	C	e	E	G	H	K	N	Ss	Sr	Code ¹⁾
PF●	1M	23.8	14.2	M12x1.0	12.4	12.8	12.9	1.5	18.4	12.2	12.2	A
PF●	2M	26.9	17.2	M15x1.0	15.5	12.8	15.1	1.5	20.6	12.2	12.2	B
PF●	3M	29.0	19.2	M18x1.0	17.5	12.8	16.6	1.5	22.1	12.2	12.2	C
PF●	TM	31.4	22.0	M18x1.0	19.8	14.5	18.3	2.0	23.8	11.7	13.6	C
PF●	4M	34.6	24.5	M22x1.0	22.6	14.5	20.6	2.0	26.1	11.7	13.6	D
PF●	LM	38.0	28.0	M25x1.0	25.8	14.5	23.0	2.0	28.5	11.7	13.6	E
PF●	5M	47.0	33.5	M31x1.0	33.0	14.5	29.4	2.0	37.0	11.7	13.6	G

Part number example: PFN.1M.305.XLMM

Panel cut-out (page 23).

Note: Ss = standard gender, Sr = reverse gender. ¹⁾ MIL-DTL-38999L shell size code (backshell not supplied)

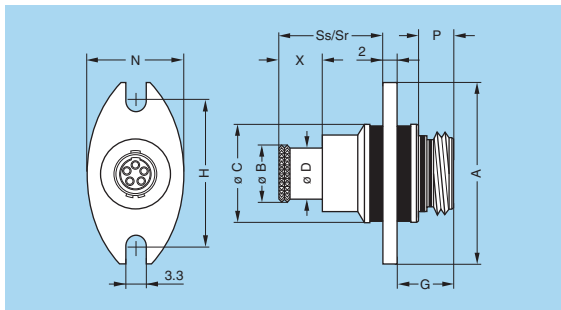

PB● Fixed socket with antivibration flange, key (N) or keys (P, R, S, T, U, V, W and X), 2 holes fixing

Reference		Dimensions (mm)										
Model	Series	A	B	C	D	G	H	N	P	Ss	Sr	X
PB●	0M	27.0	8.8	14.5	8.0	8.3	21.4	16.0	5.3	15.3	15.3	6.7
PB●	1M	29.0	10.5	16.5	9.7	8.3	23.4	18.0	5.3	15.3	15.3	6.7
PB●	2M	32.0	14.0	19.5	13.0	8.3	26.4	21.0	5.3	15.7	15.7	7.1
PB●	3M	35.0	16.0	21.5	15.0	8.3	29.0	23.0	5.3	15.7	15.7	7.1
PB●	TM	38.5	17.9	24.5	16.7	11.0	32.5	26.0	7.9	15.2	17.1	7.6
PB●	4M	41.0	20.7	27.5	19.5	11.0	35.0	29.0	7.9	15.2	17.1	7.6
PB●	LM	44.0	23.9	30.5	22.7	11.0	38.0	32.0	7.9	15.2	17.1	7.6
PB●	5M	51.0	29.7	37.5	28.5	11.0	45.0	39.0	7.9	15.2	17.1	7.6

Part number example: PBN.1M.305.XLM

Panel cut-out (page 23).

Note: Ss = standard gender, Sr = reverse gender

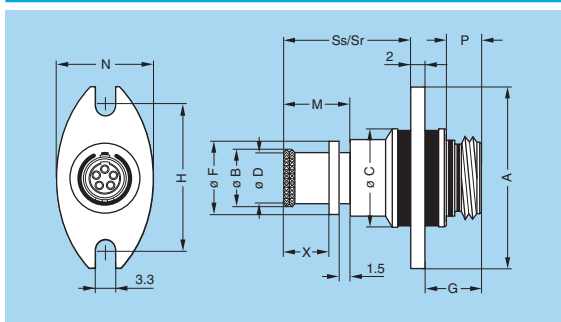

PB● Fixed socket with antivibration flange, key (N) or keys (P, R, S, T, U, V, W and X), 2 holes fixing with mold stop

Reference		Dimensions (mm)												
Model	Series	A	B	C	D	F	G	H	M	N	P	Ss	Sr	X
PB●	0M	27.0	8.8	14.5	8.0	10.7	8.3	21.4	9.7	16	5.3	18.3	18.3	6.7
PB●	1M	29.0	10.5	16.5	9.7	12.4	8.3	23.4	9.7	18	5.3	18.3	18.3	6.7
PB●	2M	32.0	14.0	19.5	13.0	15.5	8.3	26.4	10.1	21	5.3	18.7	18.7	7.1
PB●	3M	35.0	16.0	21.5	15.0	17.5	8.3	29.0	10.1	23	5.3	18.7	18.7	7.1
PB●	TM	38.5	17.9	24.5	16.7	19.8	11.0	32.5	10.6	26	7.9	18.2	18.2	7.6
PB●	4M	41.0	20.7	27.5	19.5	22.6	11.0	35.0	10.6	29	7.9	18.2	18.2	7.6
PB●	LM	44.0	23.9	30.5	22.7	25.8	11.0	38.0	10.6	32	7.9	18.2	18.2	7.6
PB●	5M	51.0	29.7	37.5	28.5	31.4	11.0	45.0	10.6	39	7.9	18.2	18.2	7.6

Part number example: PBN.1M.305.XLMT

Panel cut-out (page 23).

Note: Ss = standard gender, Sr = reverse gender

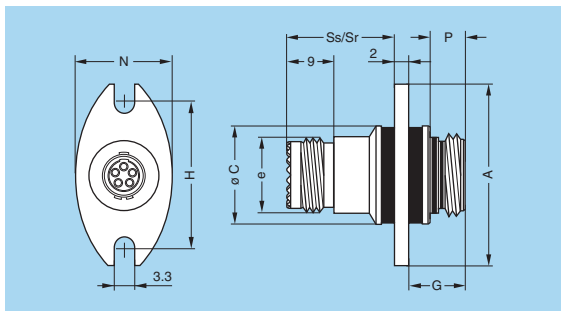

PB● Fixed socket with antivibration flange, key (N) or keys (P, R, S, T, U, V, W and X), 2 holes fixing with MIL-DTL-38999L shell thread

Reference		Dimensions (mm)									
Model	Series	A	C	e	G	H	N	P	Ss	Sr	Code ¹⁾
PB●	1M	29.0	16.5	M12x1.0	8.3	23.4	18.0	5.3	17.2	17.2	A
PB●	2M	32.0	19.5	M15x1.0	8.3	26.4	21.0	5.3	17.2	17.2	B
PB●	3M	35.0	21.5	M18x1.0	8.3	29.0	23.0	5.3	17.2	17.2	C
PB●	TM	38.5	24.5	M18x1.0	11.0	32.5	26.0	7.9	16.2	17.1	C
PB●	4M	41.0	27.5	M22x1.0	11.0	35.0	29.0	7.9	16.2	17.1	D
PB●	LM	44.0	30.5	M25x1.0	11.0	38.0	32.0	7.9	16.2	17.1	E
PB●	5M	51.0	37.5	M31x1.0	11.0	45.0	39.0	7.9	16.2	17.1	G

Part number example: PBN.1M.305.XLMM

Panel cut-out (page 23).

Note: Ss = standard gender, Sr = reverse gender. ¹⁾ MIL-DTL-38999L shell size code (backshell not supplied)

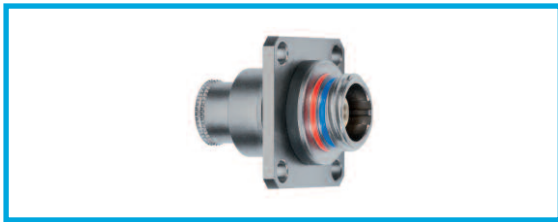

PV● Fixed socket with antivibration square flange, key (N) or keys (P, R, S, T, U, V, W and X)

Reference		Dimensions (mm)											
Model	Series	A	B	C	D	G	H	N	P	Ss	Sr	V	X
PV●	0M	26.9	8.8	14.5	8.0	8.3	15.1	20.6	5.3	15.3	15.3	2.7	6.7
PV●	1M	31.4	10.5	16.5	9.7	8.3	18.3	23.8	5.3	15.3	15.3	3.3	6.7
PV●	2M	34.6	14.0	19.5	13.0	8.3	20.6	26.1	5.3	15.7	15.7	3.3	7.1
PV●	3M	38.0	16.0	21.5	15.0	8.3	23.0	28.5	5.3	15.7	15.7	3.3	7.1
PV●	TM	40.3	17.9	24.5	16.7	11.0	24.6	30.1	7.9	15.2	17.1	3.3	7.6
PV●	4M	43.7	20.7	27.5	19.5	11.0	27.0	32.5	7.9	15.2	17.1	3.3	7.6
PV●	LM	47.1	23.9	30.5	22.7	11.0	29.4	34.9	7.9	15.2	17.1	3.3	7.6
PV●	5M	54.9	29.7	37.5	28.5	11.0	34.9	40.4	7.9	15.2	17.1	3.3	7.6

Part number example: PVN.1M.305.XLM

Panel cut-out (page 23).

Note: Ss = standard gender, Sr = reverse gender

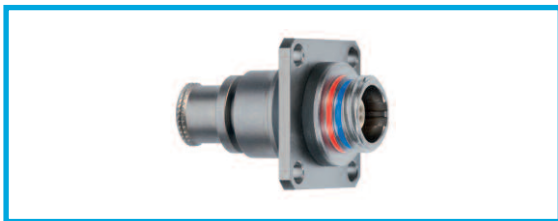
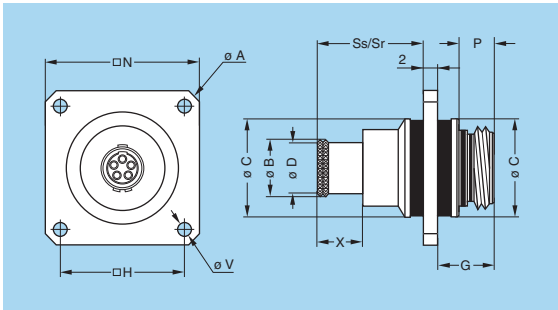

PV● Fixed socket with antivibration square flange, key (N) or keys (P, R, S, T, U, V, W and X) with mold stop

Reference		Dimensions (mm)												
Model	Series	A	B	C	D	F	G	H	M	N	P	Ss	Sr	X
PV●	0M	26.9	8.8	14.5	8.0	10.7	8.3	15.1	9.7	20.6	5.3	18.3	18.3	6.7
PV●	1M	31.4	10.5	16.5	9.7	12.4	8.3	18.3	9.7	23.8	5.3	18.3	18.3	6.7
PV●	2M	34.6	14.0	19.5	13.0	15.5	8.3	20.6	10.1	26.1	5.3	18.7	18.7	7.1
PV●	3M	38.0	16.0	21.5	15.0	17.5	8.3	23.0	10.1	28.5	5.3	18.7	18.7	7.1
PV●	TM	40.3	17.9	24.5	16.7	19.8	11.0	24.6	10.6	30.1	7.9	18.2	18.2	7.6
PV●	4M	43.7	20.7	27.5	19.5	22.6	11.0	27.0	10.6	32.5	7.9	18.2	18.2	7.6
PV●	LM	47.1	23.9	30.5	22.7	25.8	11.0	29.4	10.6	34.9	7.9	18.2	18.2	7.6
PV●	5M	54.9	29.7	37.5	28.5	31.4	11.0	34.9	10.6	40.4	7.9	18.2	18.2	7.6

Part number example: PVN.1M.305.XLMT

Panel cut-out (page 23).

Note: Ss = standard gender, Sr = reverse gender. The dimension «V» is the same as the PV● models without mold stop.

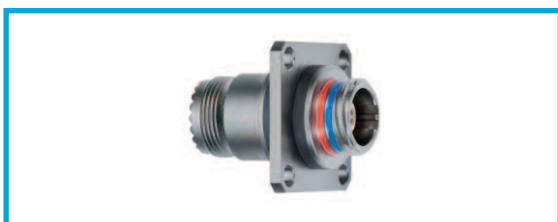
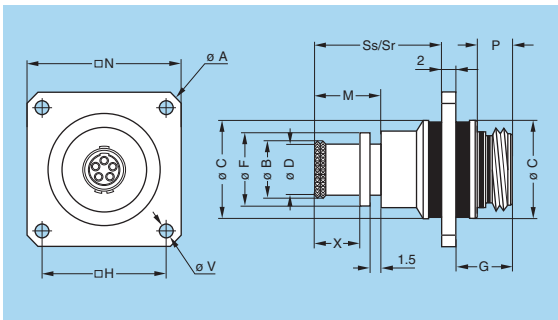

PV● Fixed socket with antivibration square flange, key (N) or keys (P, R, S, T, U, V, W and X) with MIL-DTL-38999L shell thread

Reference		Dimensions (mm)										
Model	Series	A	C	e	G	H	N	P	Ss	Sr	V	Code ¹⁾
PV●	1M	31.4	16.5	M12x1.0	8.3	18.3	23.8	5.3	17.2	17.2	3.3	A
PV●	2M	34.6	19.5	M15x1.0	8.3	20.6	26.1	5.3	17.2	17.2	3.3	B
PV●	3M	38.0	21.5	M18x1.0	8.3	23.0	28.5	5.3	17.2	17.2	3.3	C
PV●	TM	40.3	24.5	M18x1.0	11.0	24.6	30.1	7.9	16.2	17.1	3.3	C
PV●	4M	43.7	27.5	M22x1.0	11.0	27.0	32.5	7.9	16.2	17.1	3.3	D
PV●	LM	47.1	30.5	M25x1.0	11.0	29.4	34.9	7.9	16.2	17.1	3.3	E
PV●	5M	54.9	37.5	M31x1.0	11.0	34.9	40.4	7.9	16.2	17.1	3.3	G

Part number example: PVN.1M.305.XLMM

Panel cut-out (page 23).

Note: Ss = standard gender, Sr = reverse gender. ¹⁾ MIL-DTL-38999L shell size code (backshell not supplied)

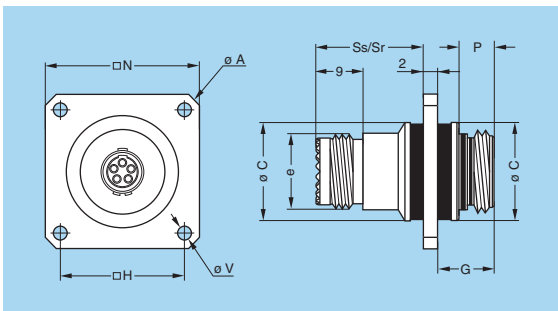

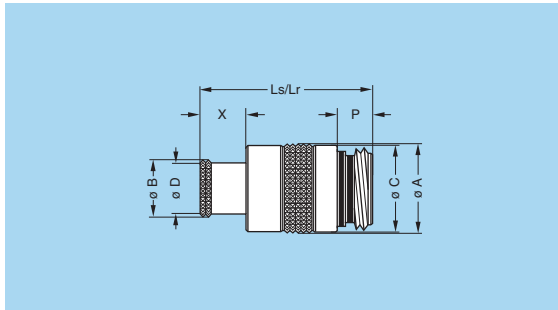

PM● Free socket, key (N) or keys (P, R, S, T, U, V, W and X) with knurled grip

Reference		Dimensions (mm)							
Model	Series	A	B	C	D	Ls	Lr	P	X
PM●	0M	13.1	8.8	12.7	8.0	25.6	25.6	5.3	6.7
PM●	1M	14.6	10.5	14.2	9.7	25.6	25.6	5.3	6.7
PM●	2M	17.6	14.0	17.2	13.0	26.0	26.0	5.3	7.1
PM●	3M	19.6	16.0	19.2	15.0	26.0	26.0	5.3	7.1
PM●	TM	22.5	17.9	22.0	16.7	28.2	30.1	7.9	7.6
PM●	4M	25.0	20.7	24.5	19.5	28.2	30.1	7.9	7.6
PM●	LM	28.5	23.9	28.0	22.7	28.2	30.1	7.9	7.6
PM●	5M	34.0	29.7	33.5	28.5	28.2	30.1	7.9	7.6

Part number example: PMN.1M.305.XLM

Note: Ls = standard gender, Lr = reverse gender

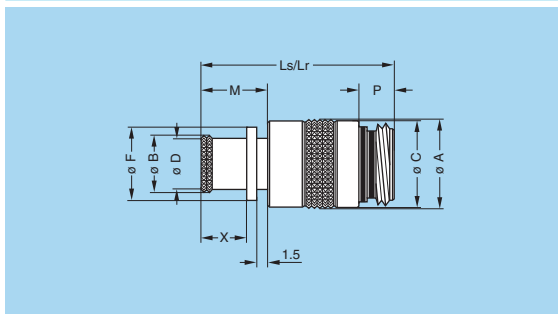

PM● Free socket, key (N) or keys (P, R, S, T, U, V, W and X) with knurled grip and mold stop

Reference		Dimensions (mm)									
Model	Series	A	B	C	D	F	Ls	Lr	M	P	X
PM●	0M	13.1	8.8	12.7	8.0	10.7	28.6	28.6	9.7	5.3	6.7
PM●	1M	14.6	10.5	14.2	9.7	12.4	28.6	28.6	9.7	5.3	6.7
PM●	2M	17.6	14.0	17.2	13.0	15.5	29.0	29.0	10.1	5.3	7.1
PM●	3M	19.6	16.0	19.2	15.0	17.5	29.0	29.0	10.1	5.3	7.1
PM●	TM	22.5	17.9	22.0	16.7	19.8	31.2	31.2	10.6	7.9	7.6
PM●	4M	25.0	20.7	24.5	19.5	22.6	31.2	31.2	10.6	7.9	7.6
PM●	LM	28.5	23.9	28.0	22.7	25.8	31.2	31.2	10.6	7.9	7.6
PM●	5M	34.0	29.7	33.5	28.5	31.4	31.2	31.2	10.6	7.9	7.6

Part number example: PMN.1M.305.XLMT

Note: Ls = standard gender, Lr = reverse gender

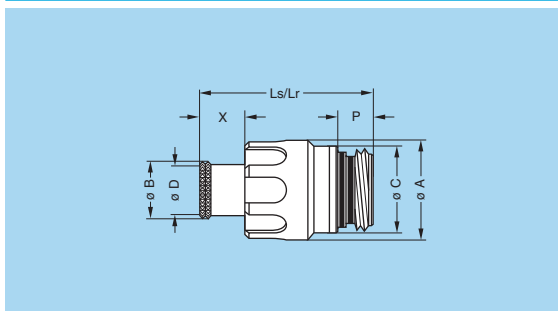

PH● Free socket, key (N) or keys (P, R, S, T, U, V, W and X) with arctic grip

Reference		Dimensions (mm)							
Model	Series	A	B	C	D	Ls	Lr	P	X
PH●	0M	14.4	8.8	12.7	8.0	25.6	25.6	5.3	6.7
PH●	1M	15.9	10.5	14.2	9.7	25.6	25.6	5.3	6.7
PH●	2M	18.9	14.0	17.2	13.0	26.0	26.0	5.3	7.1
PH●	3M	20.9	16.0	19.2	15.0	26.0	26.0	5.3	7.1
PH●	TM	23.4	17.9	22.0	16.7	28.2	30.1	7.9	7.6
PH●	4M	25.9	20.7	24.5	19.5	28.2	30.1	7.9	7.6
PH●	LM	29.4	23.9	28.0	22.7	28.2	30.1	7.9	7.6
PH●	5M	34.9	29.7	33.5	28.5	28.2	30.1	7.9	7.6

Part number example: PHN.1M.305.XLM

Note: Ls = standard gender, Lr = reverse gender



PH● Free socket, key (N) or keys (P, R, S, T, U, V, W and X) with arctic grip and mold stop

Reference		Dimensions (mm)									
Model	Series	A	B	C	D	F	Ls	Lr	M	P	X
PH●	0M	14.4	8.8	12.7	8.0	10.7	28.6	28.6	9.7	5.3	6.7
PH●	1M	15.9	10.5	14.2	9.7	12.4	28.6	28.6	9.7	5.3	6.7
PH●	2M	18.9	14.0	17.2	13.0	15.5	29.0	29.0	10.1	5.3	7.1
PH●	3M	20.9	16.0	19.2	15.0	17.5	29.0	29.0	10.1	5.3	7.1
PH●	TM	23.4	17.9	22.0	16.7	19.8	31.2	31.2	10.6	7.9	7.6
PH●	4M	25.9	20.7	24.5	19.5	22.6	31.2	31.2	10.6	7.9	7.6
PH●	LM	29.4	23.9	28.0	22.7	25.8	31.2	31.2	10.6	7.9	7.6
PH●	5M	34.9	29.7	33.5	28.5	31.4	31.2	31.2	10.6	7.9	7.6

Part number example: PHN.1M.305.XLMT

Note: Ls = standard gender, Lr = reverse gender

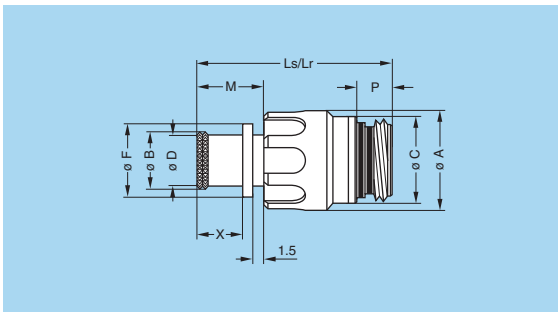

Watertight model (unmated)



HE● Fixed socket, nut fixing, key (N) or keys (P, R, S, T, U, V, W and X) for printed circuit, watertight (back panel mounting)

Reference		Dimensions (mm)											
Model	Series	A	C	e	E	H	Ls	Lr	N	P	R	S1	S2
HE●	0M	17	16.8	M13x0.75	5.0	5.08	20.8	21.0	16.8	5.3	13.8	11.5	14
HE●	1M	18	17.8	M14x1.00	5.0	7.62	20.8	21.0	16.8	5.3	13.8	12.5	16
HE●	2M	21	20.8	M17x1.00	5.0	8.89	20.8	21.0	16.8	5.3	13.8	15.5	18
HE●	3M	23	22.8	M19x1.00	5.0	10.16	20.8	21.0	16.8	5.3	13.8	17.5	20
HE●	TM	27	25.8	M22x1.00	4.0	12.70	24.6	24.6	19.9	7.9	16.9	20.5	23
HE●	4M	29	27.8	M24x1.00	4.0	13.97	24.6	24.6	19.9	7.9	16.9	22.5	25
HE●	LM	33	31.8	M28x1.00	4.0	16.51	24.6	24.6	19.9	7.9	16.9	26.5	29
HE●	5M	38	36.8	M33x1.00	4.0	20.32	24.6	24.6	19.9	7.9	16.9	31.5	34

Part number example: HEN.1M.305.XLNP

Panel cut-out (page 23). PCB drilling pattern (page 24).

Note: Ls = standard gender, Lr = reverse gender

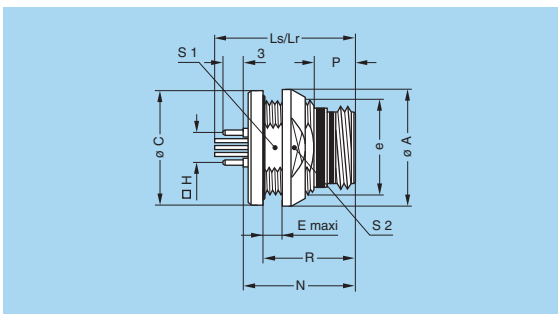

▶ **USB models**



FM ● Straight plug, key (W) or key (R)
with knurled grip and mold stop

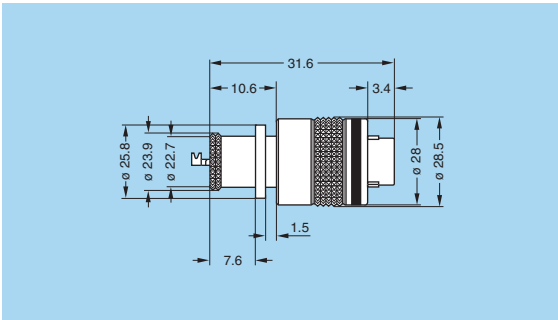

Part number
FM•LM.U2A.XPAT



FG ● Straight plug, key (W) or key (R)
with arctic grip and mold stop

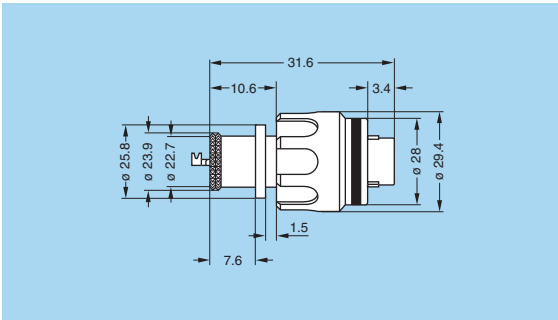

Part number
FG•LM.U2A.XPAT



EG ● Fixed socket, female to female, nut fixing,
key (W) or key (R)

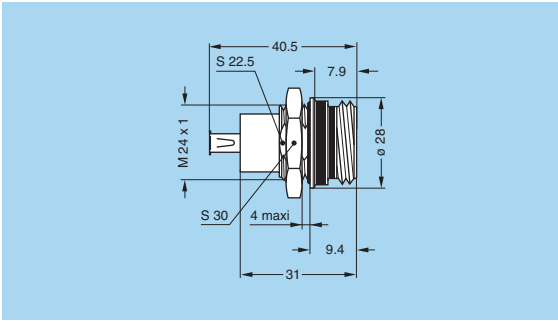

Part number
EG•LM.U2A.XPP



EG● Fixed socket, nut fixing, key (W) or key (R)

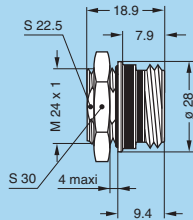

Part number
EG●.LM.U2A.XPL

Alignment Key

Alignment Key and Polarized Keying System

M series connector model part numbers are composed of three letters. The LAST LETTER indicates the keys corresponding to a particular contact type.











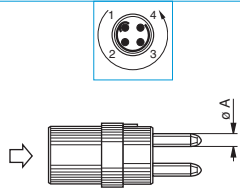
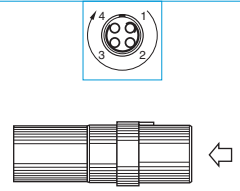



















For example, straight plugs with N, P, R, U or W keys, are fitted with male contacts; whereas with S, T, V or X keys, plugs are fitted with female contacts. Sockets with N, P, R, U or W keys, are fitted with female contacts; whereas with S, T, V or X keys, sockets are fitted with male contacts.

OM to 3M	Front view of a socket 	Model	Nb of keys	Angles		Colour code	Contact type	
				β	γ		Plug	Socket
		●●N	3	165°	30°	blue	male	female
		●●P		150°	60°	yellow		
		●●U		130°	100°	green		
		●●S		155°	50°	red	female	male
		●●T		135°	90°	orange		

TM to 5M	Front view of a socket 	Model	Nb of keys	Angles				Colour code	Contact type	
				α	β	γ	δ		Plug	Socket
		●●W	5	95°	115°	35°	25°	blue	male	female
		●●R		105°	115°	30°	20°	yellow		
		●●X		100°	125°	40°	20°	red	female	male
		●●V		110°	120°	35°	25°	orange		

Insert configuration

Multipole

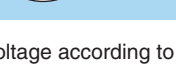
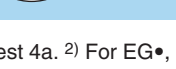
	 Male crimp contacts for plug		 Female crimp contacts for sockets		Reference	Number of contacts	ø A (mm)	Contact type		AWG	Test voltage (kV rms) ¹⁾ Contact-contact	Test voltage (kV rms) ¹⁾ Contact-shell	Rated current (A) ¹⁾
	Crimp	Print (straight) ²⁾											
0M					302	2	0.9	●	●	20-22-24	1.45	1.00	10.0
					303	3	0.9	●	●	20-22-24	1.70	1.40	8.0
					304	4	0.7	●	●	22-24-26	1.35	0.90	7.0
					305	5	0.7	●	●	22-24-26	1.25	1.00	6.5
1M					302	2	1.3	●	–	16-18-20	1.55	1.10	19.0
					305	5	0.9	●	●	20-22-24	1.30	1.30	9.0
					307	7	0.7	●	●	22-24-26	1.45	1.20	7.0
					308	8	0.7	●	●	22-24-26	1.30	1.10	5.0
2M					308	8	0.9	●	●	20-22-24	1.95	1.10	10.0
					310	10	0.9	●	●	20-22-24	1.80	1.20	8.0
					312	12	0.7	●	●	22-24-26	1.65	1.15	7.0
					319	19	0.7	●	●	22-24-26	1.20	1.00	4.0
3M					322	22	0.7	●	●	22-24-26	tbd	tbd	tbd
					330	30	0.7	●	●	22-24-26	1.10	1.00	3.5
TM					325	25	0.9	●	●	20-22-24	1.10	1.25	5.0
					340	40	0.7	●	●	22-24-26	1.05	1.20	3.0

Note: ¹⁾ Test voltage according to IEC 60512-2 test 4a. ²⁾ For EG•, EC•, ED•, HE• socket.

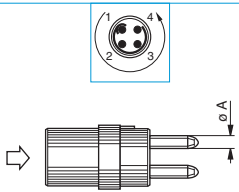
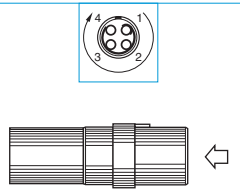
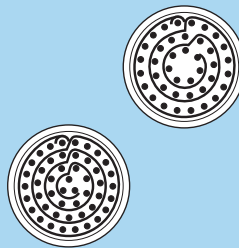
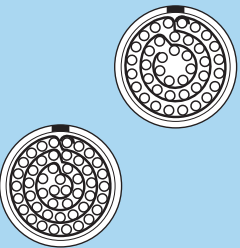
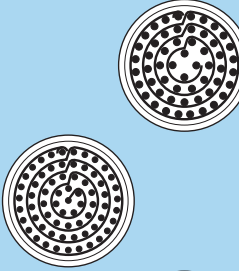
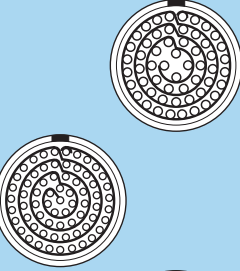
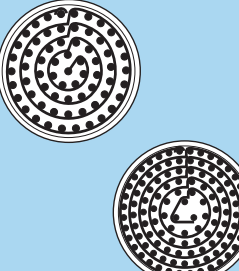
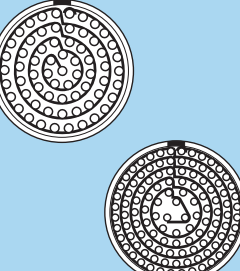

Multipole

	 Male crimp contacts for plug	 Female crimp contacts for sockets	Reference	Number of contacts	ø A (mm)	Contact type		AWG	Test voltage (kV rms) ¹⁾ Contact-contact	Test voltage (kV rms) ¹⁾ Contact-shell	Rated current (A) ¹⁾
						Crimp	Print (straight) ²⁾				
4M			340	40	0.7	●	●	22-24-26	1.20	1.35	3.5
			348	48	0.7	●	●	22-24-26	1.10	1.35	3.0
LM			355	55	0.9	●	●	20-22-24	tbd	tbd	tbd
			368	68	0.7	●	●	22-24-26	1.40	1.65	2.5
			U2A	4	–	Solder	–	1.20	0.95	n.a.	
5M			366	66	0.9	●	●	20-22-24	1.60	1.70	3.0
			114	114	0.7	●	●	22-24-26	1.37	1.34	2.0

Note: ¹⁾ Test voltage according to IEC 60512-2 test 4a. ²⁾ For EG●, EC●, ED●, HE● socket. ³⁾ Front view.

▶ Housings

Ref.	Outer shell	
	Material	Surface treatment
C	Brass	Chrome
X	Aluminium alloy	Nickel ¹⁾

Note: ¹⁾ anthracite colour.

Contacts

Crimp contacts for plugs, free or fixed sockets

There are 2 forms of crimp barrels:

- per fig. 1, the standard design
- per fig. 2, with reduced crimp barrel for small conductors.

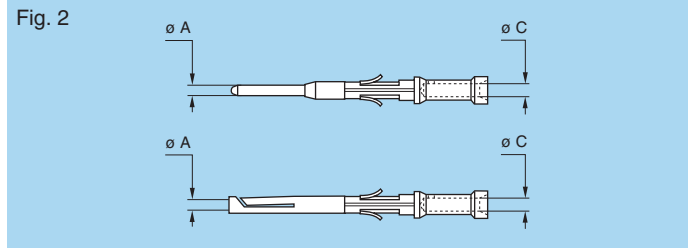
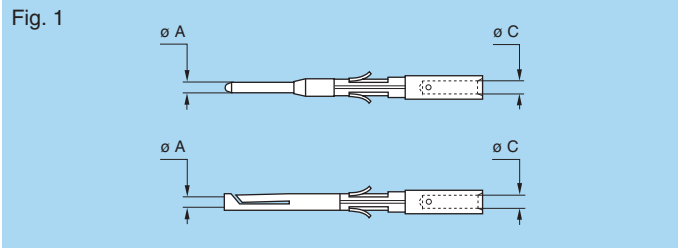

Ref.	Contact type	Ref.	Contact type
C	Male crimp (fig. 1)	M	Female crimp (fig. 1)
B	Male crimp (fig. 2)	P	Female crimp (fig. 2)
D	Male straight print	N	Female straight print

Dimension of crimp barrels

	Type	Contact			Ref. contact type		Conductor				Part number	
		$\varnothing A$ (mm)	$\varnothing C$ (mm)	Form per fig.	Male	Female	AWG		Section (mm ²)		For male contacts	For female contacts
							min.	max.	min.	max.		
0M	302-303	0.9	1.10	1	C	M	24	20	0.204	0.616	FGN.0M.560.ZZC	EGN.0M.660.ZZM
		0.9	0.87	2	B	P	26	22	0.128	0.382	FGN.0M.561.ZZC	EGN.0M.661.ZZM
	304-305	0.7	0.87	1	C	M	26	22	0.128	0.382	FGN.0M.555.ZZC	EGN.0M.655.ZZM
		0.7	0.44	2	B	P	32	28	0.032	0.092	FGN.0M.556.ZZC	EGN.0M.656.ZZM
1M	302	1.3	1.60	1	C	M	20	16	0.616	2.000	FGN.0M.565.ZZC	EGN.0M.665.ZZM
	305	0.9	1.10	1	C	M	24	20	0.204	0.616	FGN.0M.560.ZZC	EGN.0M.660.ZZM
		0.9	0.87	2	B	P	26	22	0.128	0.382	FGN.0M.561.ZZC	EGN.0M.661.ZZM
	307-308	0.7	0.87	1	C	M	26	22	0.128	0.382	FGN.0M.555.ZZC	EGN.0M.655.ZZM
0.7		0.44	2	B	P	32	28	0.032	0.092	FGN.0M.556.ZZC	EGN.0M.656.ZZM	
2M	308-310	0.9	1.10	1	C	M	24	20	0.204	0.616	FGN.0M.560.ZZC	EGN.0M.660.ZZM
		0.9	0.87	2	B	P	26	22	0.128	0.382	FGN.0M.561.ZZC	EGN.0M.661.ZZM
	312-319	0.7	0.87	1	C	M	26	22	0.128	0.382	FGN.0M.555.ZZC	EGN.0M.655.ZZM
		0.7	0.44	2	B	P	32	28	0.032	0.092	FGN.0M.556.ZZC	EGN.0M.656.ZZM
3M	322-330	0.7	0.87	1	C	M	26	22	0.128	0.382	FGN.0M.555.ZZC	EGN.0M.655.ZZM
		0.7	0.44	2	B	P	32	28	0.032	0.092	FGN.0M.556.ZZC	EGN.0M.656.ZZM
TM	325	0.9	1.10	1	C	M	24	20	0.204	0.616	FGN.0M.560.ZZC	EGW.TM.660.ZZM
		0.9	0.87	2	B	P	26	22	0.128	0.382	FGN.0M.561.ZZC	EGW.TM.661.ZZM
	340	0.7	0.87	1	C	M	26	22	0.128	0.382	FGN.0M.555.ZZC	EGW.TM.655.ZZM
		0.7	0.44	2	B	P	32	28	0.032	0.092	FGN.0M.556.ZZC	EGW.TM.656.ZZM
4M	340-348	0.7	0.87	1	C	M	26	22	0.128	0.382	FGN.0M.555.ZZC	EGW.TM.655.ZZM
		0.7	0.44	2	B	P	32	28	0.032	0.092	FGN.0M.556.ZZC	EGW.TM.656.ZZM
LM	355	0.9	1.10	1	C	M	24	20	0.204	0.616	FGN.0M.560.ZZC	EGW.TM.660.ZZM
		0.9	0.87	2	B	P	26	22	0.128	0.382	FGN.0M.561.ZZC	EGW.TM.661.ZZM
	368	0.7	0.87	1	C	M	26	22	0.128	0.382	FGN.0M.555.ZZC	EGW.TM.655.ZZM
		0.7	0.44	2	B	P	32	28	0.032	0.092	FGN.0M.556.ZZC	EGW.TM.656.ZZM
5M	366	0.9	1.10	1	C	M	24	20	0.204	0.616	FGN.0M.560.ZZC	EGW.TM.660.ZZM
		0.9	0.87	2	B	P	26	22	0.128	0.382	FGN.0M.561.ZZC	EGW.TM.661.ZZM
	114	0.7	0.87	1	C	M	26	22	0.128	0.382	FGN.0M.555.ZZC	EGW.TM.655.ZZM
		0.7	0.44	2	B	P	32	28	0.032	0.092	FGN.0M.556.ZZC	EGW.TM.656.ZZM

Note: In order to satisfy crimp pull-test requirements to the IEC 60352-2 standard, the use of single strand cables should be avoided.

Accessories

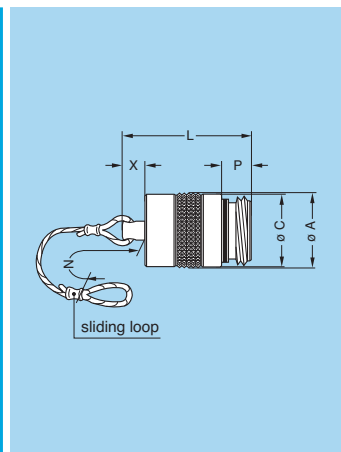

BMF Blanking caps for plugs

Part number	Dimensions (mm)					
	A	C	L	N	P	X
BMF.0M.100.●AV	13.1	12.7	24.6	85.0	5.3	6.0
BMF.1M.100.●AV	14.6	14.2	24.6	85.0	5.3	6.0
BMF.2M.100.●AV	17.6	17.2	24.6	85.0	5.3	6.0
BMF.3M.100.●AV	19.6	19.2	24.6	120.0	5.3	6.0
BMF.TM.100.●AV	22.5	22.0	31.1	120.0	7.9	10.0
BMF.4M.100.●AV	25.0	24.5	31.1	120.0	7.9	10.0
BMF.LM.100.●AV	28.5	28.0	31.1	150.0	7.9	10.0
BMF.5M.100.●AV	34.0	33.5	31.1	150.0	7.9	10.0

Note: this cap is suitable for use with any alignment key configuration. The position «●» of the part number indicates the housing material. See page 17.

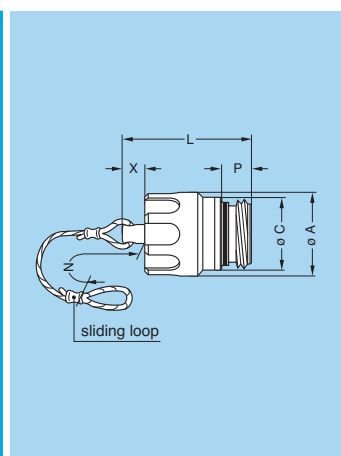

BGF Blanking caps for plugs

Part number	Dimensions (mm)					
	A	C	L	N	P	X
BGF.0M.100.●AV	14.4	12.7	24.6	85.0	5.3	6.0
BGF.1M.100.●AV	15.9	14.2	24.6	85.0	5.3	6.0
BGF.2M.100.●AV	18.9	17.2	24.6	85.0	5.3	6.0
BGF.3M.100.●AV	20.9	19.2	24.6	120.0	5.3	6.0
BGF.TM.100.●AV	23.4	22.0	31.1	120.0	7.9	10.0
BGF.4M.100.●AV	25.9	24.5	31.1	120.0	7.9	10.0
BGF.LM.100.●AV	29.4	28.0	31.1	150.0	7.9	10.0
BGF.5M.100.●AV	34.9	33.5	31.1	150.0	7.9	10.0

Note: this cap is suitable for use with any alignment key configuration. The position «●» of the part number indicates the housing material. See page 17.

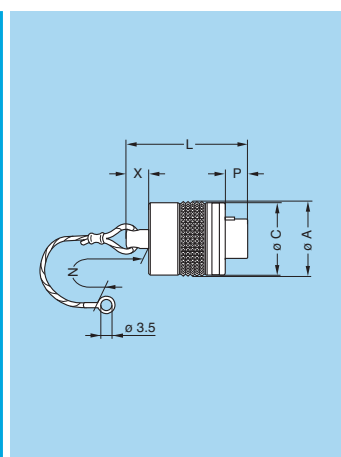

BME Blanking caps for fixed sockets

Part number	Dimensions (mm)					
	A	C	L	N	P	X
BME.0M.200.●AZ	13.1	12.7	23.4	85.0	3.9	6.0
BME.1M.200.●AZ	14.6	14.2	23.4	85.0	3.9	6.0
BME.2M.200.●AZ	17.6	17.2	23.4	85.0	3.9	6.0
BME.3M.200.●AZ	19.6	19.2	23.4	120.0	3.9	6.0
BME.TM.200.●AZ	22.5	22.0	31.0	120.0	3.4	10.0
BME.4M.200.●AZ	25.0	24.5	31.0	120.0	3.4	10.0
BME.LM.200.●AZ	28.5	28.0	31.0	150.0	3.4	10.0
BME.5M.200.●AZ	34.0	33.5	31.0	150.0	3.4	10.0

Note: this cap is suitable for use with any alignment key configuration. The position «●» of the part number indicates the housing material. See page 17.

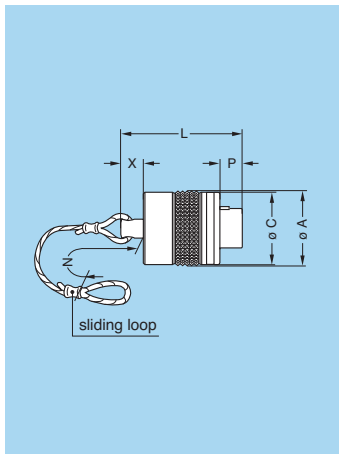

BMF Blanking caps for free sockets

Part number	Dimensions (mm)					
	A	C	L	N	P	X
BMF.0M.200.●AZ	13.1	12.7	23.4	85.0	3.9	6.0
BMF.1M.200.●AZ	14.6	14.2	23.4	85.0	3.9	6.0
BMF.2M.200.●AZ	17.6	17.2	23.4	85.0	3.9	6.0
BMF.3M.200.●AZ	19.6	19.2	23.4	120.0	3.9	6.0
BMF.TM.200.●AZ	22.5	22.0	31.0	120.0	3.4	10.0
BMF.4M.200.●AZ	25.0	24.5	31.0	120.0	3.4	10.0
BMF.LM.200.●AZ	28.5	28.0	31.0	150.0	3.4	10.0
BMF.5M.200.●AZ	34.0	33.5	31.0	150.0	3.4	10.0

Note: this cap is suitable for use with any alignment key configuration. The position «●» of the part number indicates the housing material. See page 17.

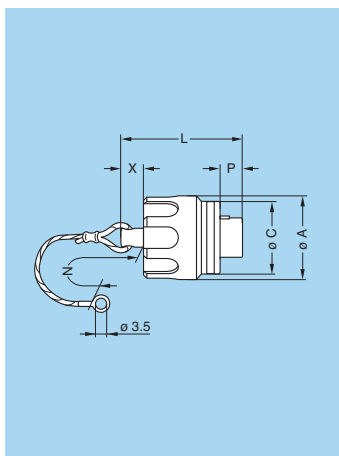

BGE Blanking caps for fixed sockets

Part number	Dimensions (mm)					
	A	C	L	N	P	X
BGE.0M.200.●AZ	14.4	12.7	23.4	85.0	3.9	6.0
BGE.1M.200.●AZ	15.9	14.2	23.4	85.0	3.9	6.0
BGE.2M.200.●AZ	18.9	17.2	23.4	85.0	3.9	6.0
BGE.3M.200.●AZ	20.9	19.2	23.4	120.0	3.9	6.0
BGE.TM.200.●AZ	23.4	22.0	31.0	120.0	3.4	10.0
BGE.4M.200.●AZ	25.9	24.5	31.0	120.0	3.4	10.0
BGE.LM.200.●AZ	29.4	28.0	31.0	150.0	3.4	10.0
BGE.5M.200.●AZ	34.9	33.5	31.0	150.0	3.4	10.0

Note: this cap is suitable for use with any alignment key configuration. The position «●» of the part number indicates the housing material. See page 17.

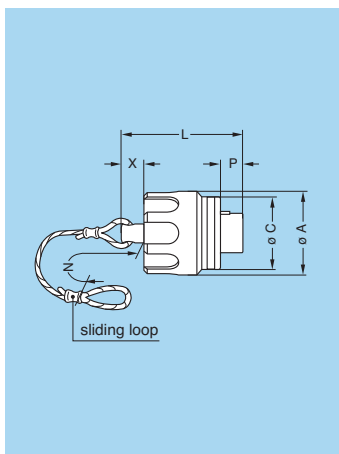

BGF Blanking caps for free sockets

Part number	Dimensions (mm)					
	A	C	L	N	P	X
BGF.0M.200.●AZ	14.4	12.7	23.4	85.0	3.9	6.0
BGF.1M.200.●AZ	15.9	14.2	23.4	85.0	3.9	6.0
BGF.2M.200.●AZ	18.9	17.2	23.4	85.0	3.9	6.0
BGF.3M.200.●AZ	20.9	19.2	23.4	120.0	3.9	6.0
BGF.TM.200.●AZ	23.4	22.0	31.0	120.0	3.4	10.0
BGF.4M.200.●AZ	25.9	24.5	31.0	120.0	3.4	10.0
BGF.LM.200.●AZ	29.4	28.0	31.0	150.0	3.4	10.0
BGF.5M.200.●AZ	34.9	33.5	31.0	150.0	3.4	10.0

Note: this cap is suitable for use with any alignment key configuration. The position «●» of the part number indicates the housing material. See page 17.

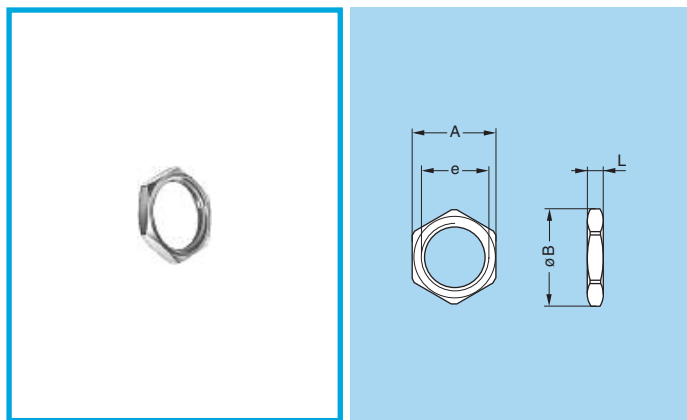

GEA Hexagonal nuts for EC• model

Part number	Series	Dimensions (mm)			
		A	B	e	L
GEA.0M.241.RL	0M	16	18.2	M13x0.75	2.5
GEA.0E.240.RL	1M	17	19.2	M14x1.00	2.5
GEA.2M.241.RL	2M	19	21.5	M17x1.00	3.0
GEA.3M.241.RL	3M	25	22.0	M19x1.00	3.0
GEA.TM.241.RL	TM	25	28.0	M22x1.00	3.0
GEA.4M.241.RL	4M	30	34.0	M24x1.00	3.0
GEA.LM.241.RL	LM	32	36.0	M28x1.00	3.0
GEA.5M.241.RL	5M	37	41.0	M33x1.00	3.0

● Material: Nickel-plated aluminium alloy (anthracite colour)

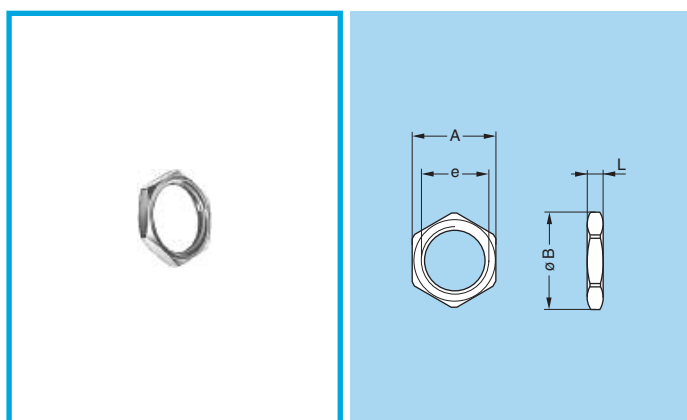

GEA Hexagonal nuts for EG• model

Part number	Series	Dimensions (mm)			
		A	B	e	L
GEA.0S.240.RL	0M	11	12.4	M9x0.60	2.0
GEA.1M.240.RL	1M	13	14.5	M11x1.00	2.5
GEA.0E.240.RL	2M	17	19.2	M14x1.00	2.5
GEA.1E.240.RL	3M	19	21.5	M16x1.00	3.0
GEA.3S.240.RL	TM	22	25.0	M18x1.00	3.0
GEA.4M.240.RL	4M	25	28.0	M21x1.00	4.0
GEA.3E.240.RL	LM	30	34.0	M24x1.00	5.0
GEA.5M.240.RL	5M	36	40.5	M30x1.00	5.0

● Material: Nickel-plated aluminium alloy (anthracite colour)

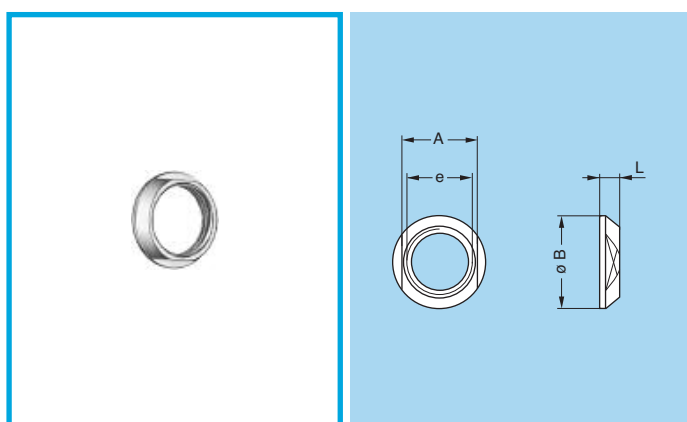

GEC Conical nut for models HE•, EC•, PE•

Part number	Series	Dimensions (mm)			
		A	B	e	L
GEC.0M.240.RN	0M	14	17	M13x0.75	3.2
GEC.0E.240.RN	1M	16	18	M14x1.00	3.0
GEC.2M.240.RN	2M	18	21	M17x1.00	3.2
GEC.3M.240.RN	3M	20	23	M19x1.00	3.2
GEC.TM.240.RN	TM	23	27	M22x1.00	5.0
GEC.4M.240.RN	4M	25	29	M24x1.00	5.0
GEC.LM.240.RN	LM	29	33	M28x1.00	5.0
GEC.5M.240.RN	5M	34	38	M33x1.00	5.0

● Material: Nickel-plated aluminium alloy (anthracite colour)

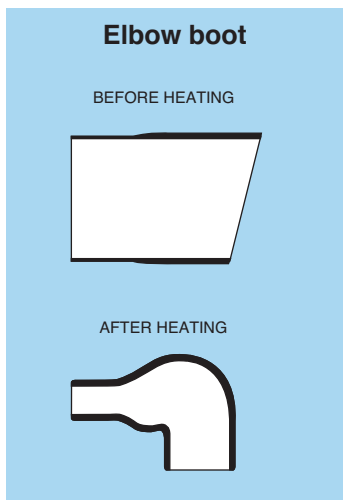
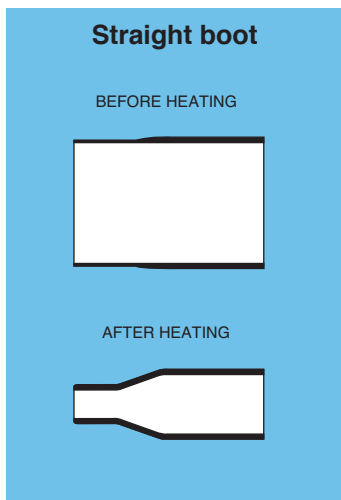

Heatsrink boot

Supplier	Part number		Series	Cable σ min. (mm)
	Straight	Elbow 90°		
Raychem®	202A111-25/86	222A111-25/86	0M-2M	3.8
	202A121-25/86	222A121-25/86	2M-4M	5.3
	202A142-25/86	222A142-25/86	4M-5M	7.4

Note: request modified elastomer resistant to fluids with hot melt sealant.

Tooling

DCE Positioners for crimp contacts

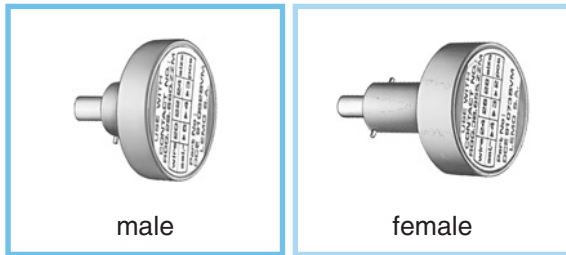

These positioners are suitable for use with both manual and pneumatic crimping tools according to the MIL-C-22520/7-01 standard.

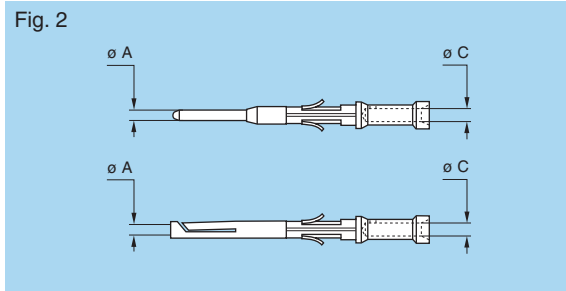
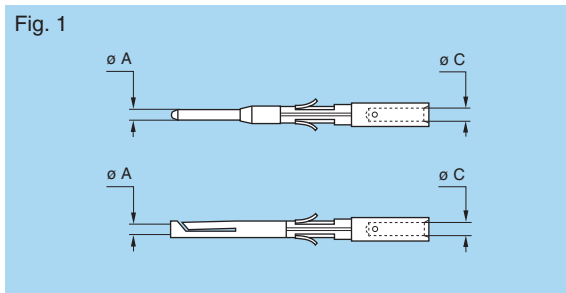

	Type	Contact		Form per fig.	Positioners part number	
		ø A (mm)	ø C (mm)		For male contacts	For female contacts
0M	302-303	0.9	1.10	1	DCE.91.090.5MVC	DCE.91.090.3MVM
		0.9	0.87	2		
	304-305	0.7	0.87	1	DCE.91.070.5MVC	DCE.91.070.3MVM
0.7		0.44	2			
1M	302	1.3	1.60	1	DCE.91.130.5MVC	DCE.91.130.5MVM
		0.9	1.10	1		
	305	0.9	0.87	2	DCE.91.090.5MVC	DCE.91.090.3MVM
		0.7	0.87	1		
307-308	0.7	0.87	1	DCE.91.070.5MVC	DCE.91.070.3MVM	
	0.7	0.44	2			
2M	308-310	0.9	1.10	1	DCE.91.090.5MVC	DCE.91.090.3MVM
		0.9	0.87	2		
	312-319	0.7	0.87	1	DCE.91.070.5MVC	DCE.91.070.3MVM
0.7		0.44	2			
3M	322-330	0.7	0.87	1	DCE.91.070.5MVC	DCE.91.070.3MVM
		0.7	0.44	2		
TM	325	0.9	1.10	1	DCE.91.090.5MVC	DCE.91.09T.5MVM
		0.9	0.87	2		
	340	0.7	0.87	1	DCE.91.070.5MVC	DCE.91.07T.5MVM
0.7		0.44	2			
4M	340-348	0.7	0.87	1	DCE.91.070.5MVC	DCE.91.07T.5MVM
		0.7	0.44	2		
LM	355	0.9	1.10	1	DCE.91.090.5MVC	DCE.91.09T.5MVM
		0.9	0.87	2		
	368	0.7	0.87	1	DCE.91.070.5MVC	DCE.91.07T.5MVM
0.7		0.44	2			
5M	366	0.9	1.10	1	DCE.91.090.5MVC	DCE.91.09T.5MVM
		0.9	0.87	2		
	114	0.7	0.87	1	DCE.91.070.5MVC	DCE.91.07T.5MVM
		0.7	0.44	2		

Note: a wide variation of strand number and diameter combinations are quoted as being AWG, some of which do not have a large enough cross section to guarantee a crimp as per either MIL-C-22520/1-01 or /7-01. Our technical department is at your disposal to study and propose a solution to all your applications.

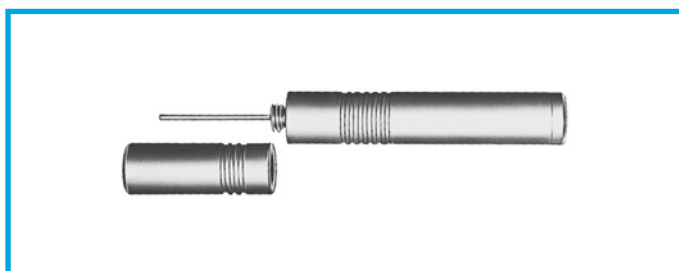

DCF Extractors for crimp contacts

Contact ø	Part number
1.3	DCF.93.131.4LT
0.9	DCF.93.090.4LT
0.7	DCF.93.070.4LT

Note: this model is used for male and female contacts.



DCM Front conical nut tightening tools

Part number	Series	For models	Torque (Nm)
DCM.04.140.PAZ	0M	EC●, HE●, PE●	1.0
DCM.04.160.PAZ	1M	EC●, HE●, PE●	1.5
DCM.04.180.PAZ	2M	EC●, HE●, PE●	2.0
DCM.04.200.PAZ	3M	EC●, HE●, PE●	2.5
DCM.08.230.PAZ	TM	EC●, HE●, PE●	4.0
DCM.08.250.PAZ	4M	EC●, HE●, PE●	5.0
DCM.08.290.PAZ	LM	EC●, HE●, PE●	6.5
DCM.08.340.PAZ	5M	EC●, HE●, PE●	8.0

Panel Cut-out

Cut-outs

EG●-EC●-HE●-PE●

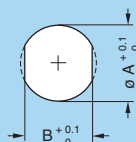

Series	EG●		EC●/HE●/PE●	
	$\varnothing A$	B	$\varnothing A$	B
0M	9.1	8.3	13.1	11.6
1M	11.1	9.6	14.1	12.6
2M	14.1	12.6	17.1	15.6
3M	16.1	14.6	19.1	17.6
TM	18.1	16.6	22.1	20.6
4M	21.1	19.6	24.1	22.6
LM	24.1	22.6	28.1	26.6
5M	30.1	28.6	33.1	31.6

Mounting nut torque (on panel)

Series	Torque (Nm)
0M	1.0
1M	1.5
2M	2.0
3M	2.5
TM	4.0
4M	5.0
LM	6.5
5M	8.0

Cut-outs

ED●-PV●-PF●

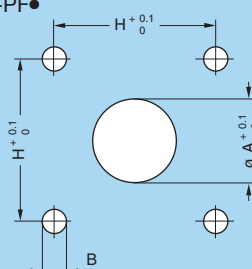

Series	ED●			PV●			PF●		
	$\varnothing A$	B	H	$\varnothing A$	B	H	$\varnothing A$	B	H
0M	5.1	M2.5	11.0	14.8	M2.5	15.1	10.8	M2.5	11.0
1M	6.1	M3.0	12.9	16.8	M3.0	18.3	12.5	M3.0	12.9
2M	9.1	M3.0	15.1	19.8	M3.0	20.6	15.6	M3.0	15.1
3M	11.1	M3.0	16.6	21.8	M3.0	23.0	18.1	M3.0	16.6
TM	12.5	M3.0	18.3	24.8	M3.0	24.6	19.9	M3.0	18.3
4M	14.1	M3.0	20.6	27.8	M3.0	27.0	22.7	M3.0	20.6
LM	18.1	M3.0	23.0	30.8	M3.0	25.4	25.9	M3.0	23.0
5M	23.2	M3.0	27.0	37.8	M3.0	34.9	33.1	M3.0	29.4

Cut-outs

PB●

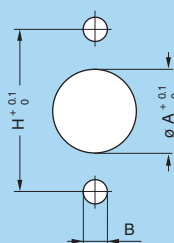

Series	PB●		
	$\varnothing A$	B	H
0M	14.8	M3.0	21.4
1M	16.8	M3.0	23.4
2M	19.8	M3.0	26.4
3M	21.8	M3.0	29.0
TM	24.8	M3.0	32.5
4M	27.8	M3.0	35.0
LM	30.8	M3.0	38.0
5M	37.8	M3.0	45.0

PCB drilling pattern

Fixed socket with straight print contact

For HE● models

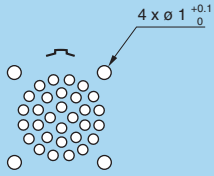

For EG●, EC● and ED● models



0M.302

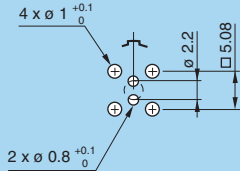

0M.303

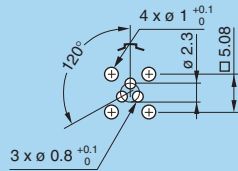

0M.304

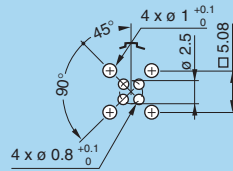

0M.305

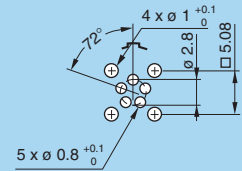

1M.305

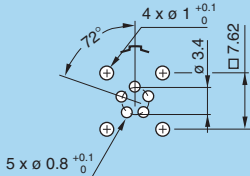

1M.307

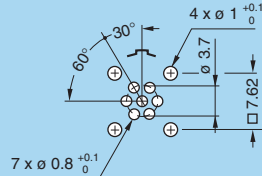

1M.308

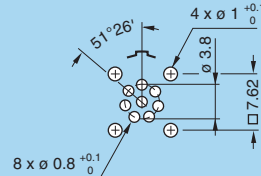

2M.308

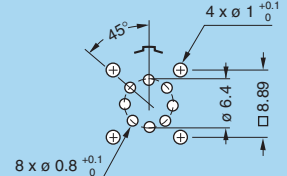

2M.310

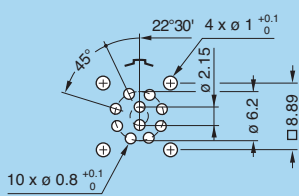

2M.312

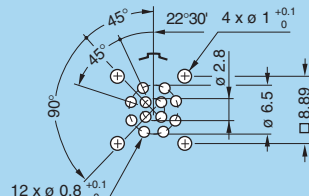

2M.319

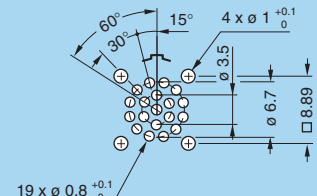

3M.322

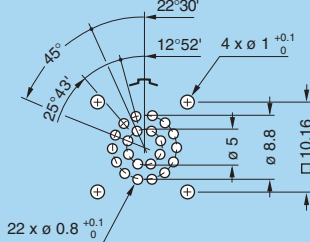

3M.330

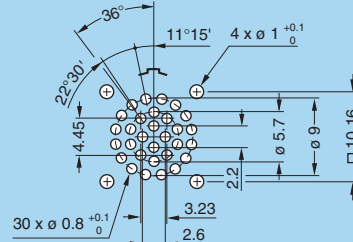

TM.325

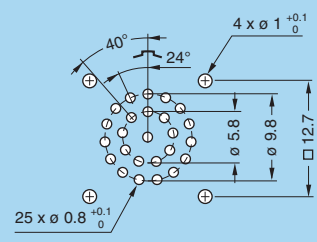

TM.340

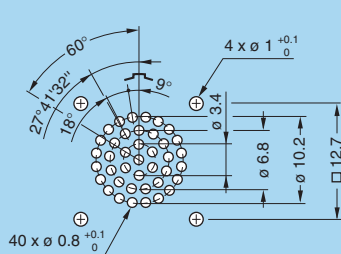

4M.340

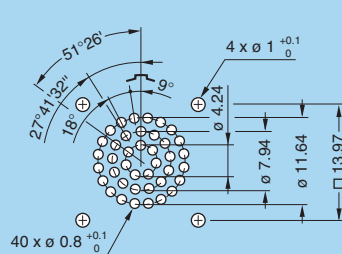

4M.348

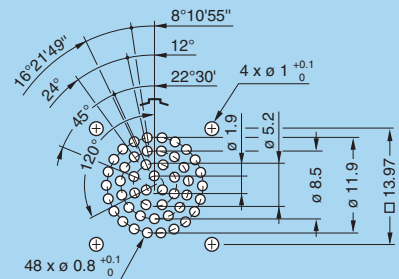

LM.355

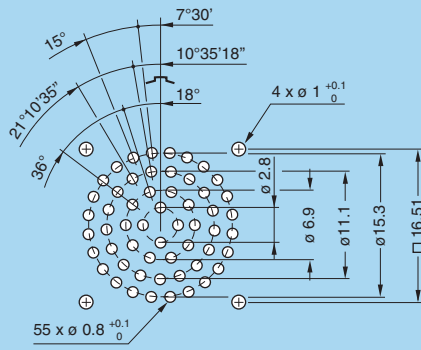

LM.368

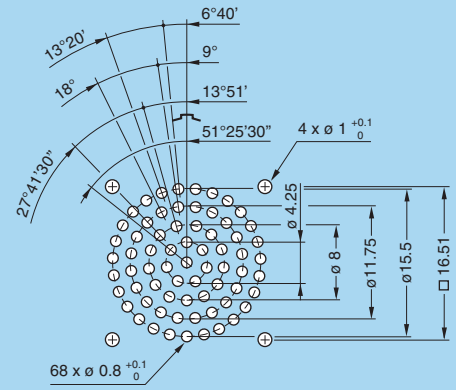

5M.366

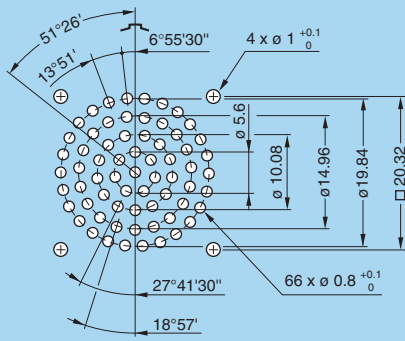

5M.114

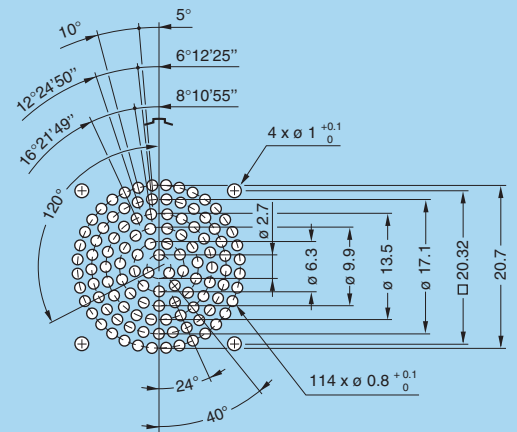

Assembly instructions for plugs and sockets

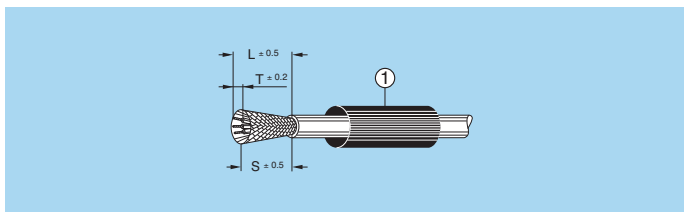
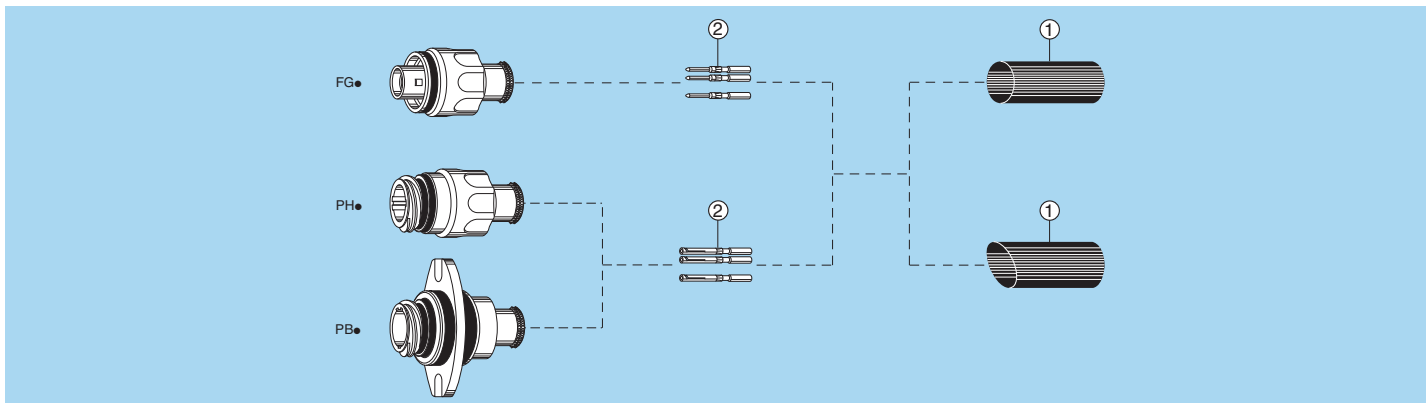

1. Cable preparation

First place the heatshrink boot ① over the cable. Strip the cable according to dimensions of the table, then widen the shield.

Series	L	S	T
0M to 5M	20	15	3.5

Note: dimensions are in mm.

2. Cable termination

2.1 With shielded cables, widen and pull the shield all the way to the back. Fix the appropriate positioner onto the crimping tool and set the selector to the number corresponding to the AWG of the conductor used as indicated on the positioner label.

Fit the conductor into the contact ②; make sure it is visible through the contact's inspection hole.

Slide the conductor-contact assembly into the open crimping tool; make sure that the contact is pushed fully into the positioner. Close the tool. Remove from crimping tool and check that conductor is secure in contact and shows in inspection hole.

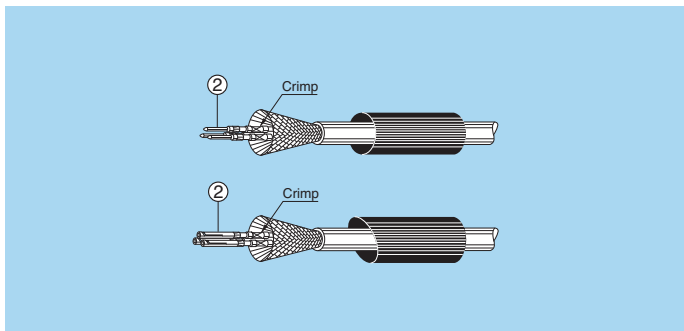

2.2 Arrange the conductor-contact assemblies according to the markings, into the rear cable seal.

Push them deeply into the insulator, using tweezers if necessary; check that all the contacts are correctly located in the insulator: 1) by verifying the alignment of the contacts at the front of the insulator and 2) by gently pulling on each conductor.

Verification should also be made using the appropriate retention testing tool.

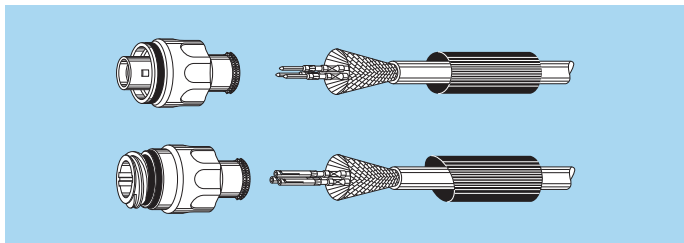

2.3 Bring the shield around the rear of connector.

Secure it with a band-it tie-wrap (not furnished) to fix the shield in place. Cut off the possible shield surplus.

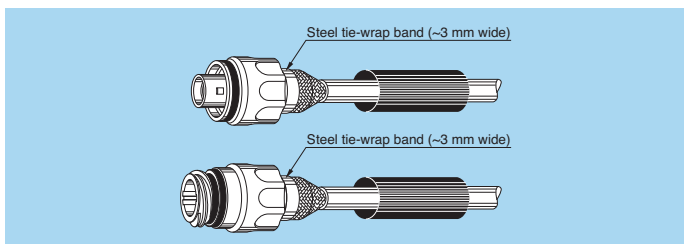

2.4 Put the heatshrink boot in place and heat gently until it retracts.

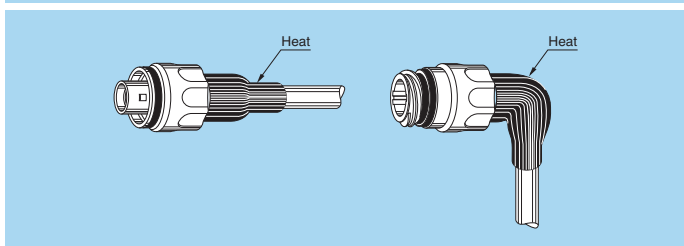

Assembly instructions for plugs and sockets (with optional mold stop)

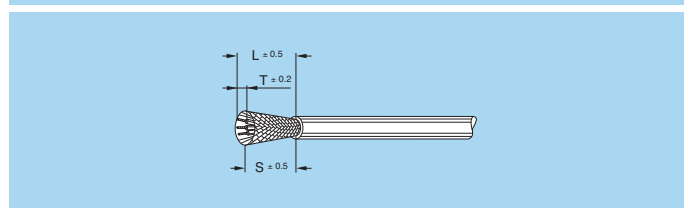
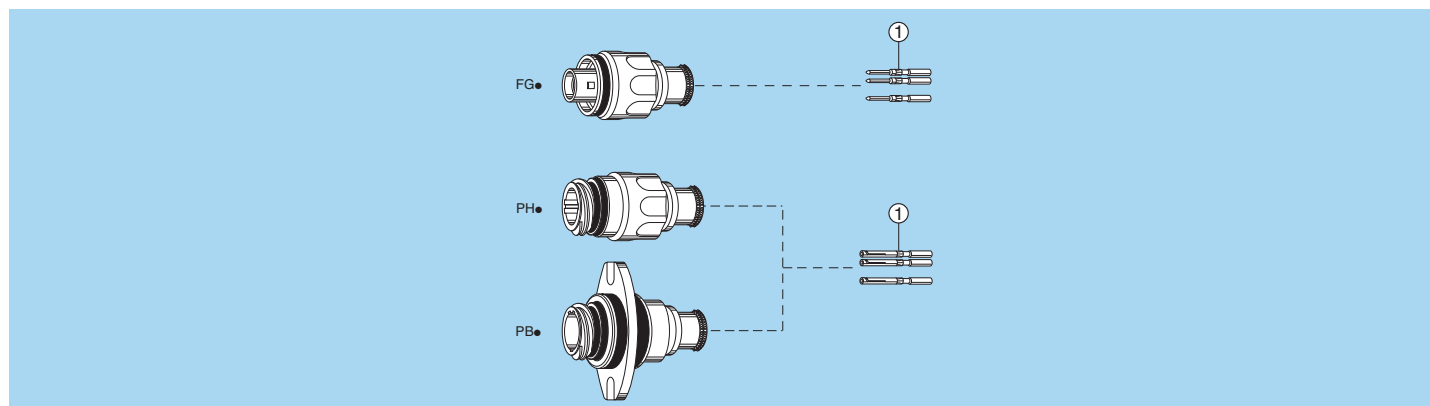

1. Cable preparation

Strip the cable according to dimensions of the table, then widen the shield.

Series	L	S	T
OM to 5M	20	15	3.5

Note: dimensions are in mm.

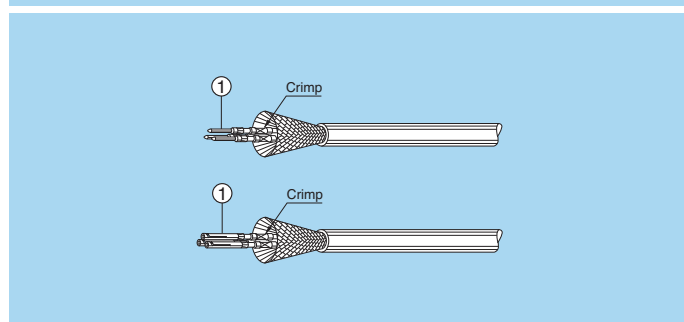

2. Cable termination

2.1 With shielded cables, widen and pull the shield all the way to the back. Fix the appropriate positioner onto the crimping tool and set the selector to the number corresponding to the AWG of the conductor used as indicated on the positioner label.

Fit the conductor into the contact ①; make sure it is visible through the contact's inspection hole.

Slide the conductor-contact assembly into the open crimping tool; make sure that the contact is pushed fully into the positioner. Close the tool. Remove from crimping tool and check that conductor is secure in contact and shows in inspection hole.

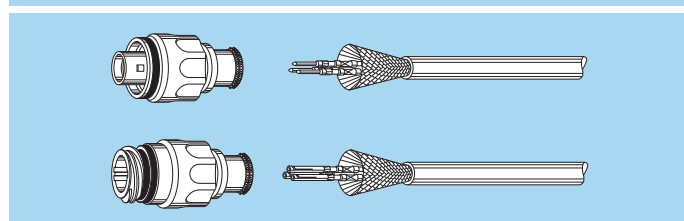

2.2 Arrange the conductor-contact assemblies according to the markings, into the rear cable seal.

Push them deeply into the insulator, using tweezers if necessary; check that all the contacts are correctly located in the insulator: 1) by verifying the alignment of the contacts at the front of the insulator and 2) by gently pulling on each conductor.

Verification should also be made using the appropriate retention testing tool.

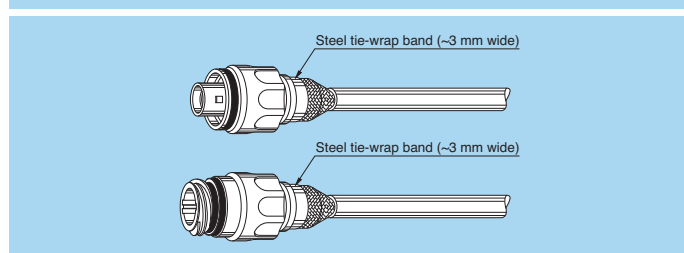

2.3 Bring the shield around the rear of connector until the mold stop. Secure it with a band-it tie-wrap (not furnished) to fix the shield in place. Cut off the possible shield surplus.

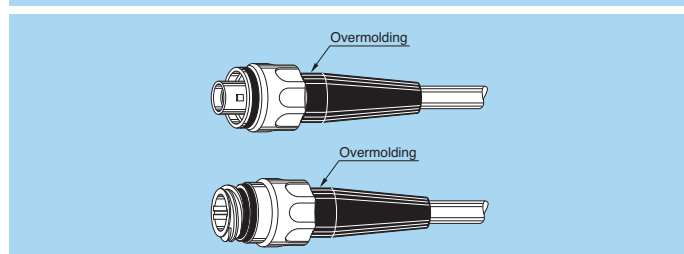

2.4 Custom overmold cable assembly.

Notes

Product safety notice

PLEASE READ AND FOLLOW ALL INSTRUCTIONS CAREFULLY AND CONSULT ALL RELEVANT NATIONAL AND INTERNATIONAL SAFETY REGULATIONS FOR YOUR APPLICATION. IMPROPER HANDLING, CABLE ASSEMBLY, OR WRONG USE OF CONNECTORS CAN RESULT IN HAZARDOUS SITUATIONS.

1. SHOCK AND FIRE HAZARD

Incorrect wiring, the use of damaged components, presence of foreign objects (such as metal debris), and / or residue (such as cleaning fluids), can result in short circuits, overheating, and / or risk of electric shock. Mated components should never be disconnected while live as this may result in an exposed electric arc and local overheating, resulting in possible damage to components.

2. HANDLING

Connectors and their components should be visually inspected for damage prior to installation and assembly. Suspect components should be rejected or returned to the factory for verification. Connector assembly and installation should only be carried out by properly trained personnel. Proper tools must be used during installation and / or assembly in order to obtain safe and reliable performance.

3. USE

Connectors with exposed contacts should never be live (or on the current supply side of a circuit). Under general conditions voltages above 30 VAC and 42 VDC are considered hazardous and proper measures should be taken to eliminate all risk of transmission of such voltages to any exposed metal part of the connector.

4. TEST AND OPERATING VOLTAGES

The maximum admissible operating voltage depends upon the national or international standards in force for the application in question. Air and creepage distances impact the operating voltage; reference values are indicated in the catalog however these may be influenced by PC board design and / or wiring harnesses. The test voltage indicated in the catalog is 75% of the mean breakdown voltage; the test is applied at 500 V/s and the test duration is 1 minute.

5. CE MARKING

CE marking  means that the appliance or equipment bearing it complies with the protection requirements of one or several European safety directives.

CE marking  applies to complete products or equipment, **but not to electromechanical components, such as connectors.**

6. PRODUCT IMPROVEMENTS

The LEMO Group reserves the right to modify and improve to our products or specifications without providing prior notification.

Data subject to change

No reproduction or use without express permission of editorial or pictorial content, in any manner.
LEMO reserve the right at all times to modify and improve specifications without any notification.

LEMO HEADQUARTERS

SWITZERLAND

LEMO SA

Chemin des Champs-Courbes 28 - P.O. Box 194 - CH-1024 Ecublens
Tel. (+41 21) 695 16 00 - Fax (+41 21) 695 16 02 - e-mail: info@lemo.com

LEMO SUBSIDIARIES

AUSTRIA

LEMO Elektronik GesmbH

Lemböckgasse 49/E6-3
1230 Wien
Tel: (+43 1) 914 23 20 0
Fax: (+43 1) 914 23 20 11
sales@lemo.at

CANADA

LEMO Canada Inc

111 Esna Park Drive, Unit 1,
Markham, Ontario L3R 1H2
Tel: (+1 905) 477 77 22
Fax: (+1 905) 477 78 13
info-canada@lemo.com

CHINA

LEMO Electronics (Shanghai) Co., Ltd

5th Floor, Block 6, City of ELITE,
1000 Jinhai Road, Pudong
Shanghai, China 201206
Tel: (+86 21) 5899 7721
Fax: (+86 21) 5899 7727
cn.sales@lemo.com

DENMARK

LEMO Denmark A/S

Gammel Mosevej 46
2820 Gentofte
Tel: (+45) 45 20 44 00
Fax: (+45) 45 20 44 01
info-dk@lemo.com

FRANCE

LEMO France Sàrl

24/28 Avenue Graham Bell
Bâtiment Balthus 4
Bussy Saint Georges
77607 Marne la Vallée Cedex 3
Tel: (+33 1) 60 94 60 94
Fax: (+33 1) 60 94 60 90
info-fr@lemo.com

GERMANY

LEMO Elektronik GmbH

Hanns-Schwindt-Str. 6
81829 München
Tel: (+49 89) 42 77 03
Fax: (+49 89) 420 21 92
info@lemo.de

HONG KONG

LEMO Hong Kong Ltd

Unit 1207, 12/F, Corporation Square,
8 Lam Lok Street, Kowloon Bay,
Kowloon - Hong Kong
Tel: (+852) 2174 0468
Fax: (+852) 2174 0492
hk.sales@lemo.com

HUNGARY

REDEL Elektronika Kft

Vágóhíd u. 26
1201 Budapest XX.
Tel: (+36 1) 421 47 10
Fax: (+36 1) 421 47 57
info-hu@lemo.com

ITALY

LEMO Italia srl

Viale Lunigiana 25
20125 Milano
Tel: (+39 02) 66 71 10 46
Fax: (+39 02) 66 71 10 66
sales.it@lemo.com

JAPAN

LEMO Japan Ltd

2-7-22, Miya,
Minato-ku, Tokyo, 108-0073
Tel: (+81 3) 54 46 55 10
Fax: (+81 3) 54 46 55 11
lemoinfo@lemo.co.jp

NETHERLANDS / BELGIUM

LEMO Connectors Benelux

De Trompet 1060
1967 DD Heemskerk
Tel: (+31) 251 25 78 20
Fax (+31) 251 25 78 21
info@lemo.nl

NORWAY / ICELAND

LEMO Norway A/S

Stanseveien 6B
0975 Oslo
Tel: (+47) 22 91 70 40
Fax: (+47) 22 91 70 41
info-no@lemo.com

SINGAPORE

LEMO Asia Pte Ltd

4 Leng Kee Road,
#06-09 SiS Building
Singapore 159088
Tel: (+65) 6476 0672
Fax: (+65) 6474 0672
sg.sales@lemo.com

SPAIN / PORTUGAL

IBERLEMO SAU

Brasil, 45, 08402 Granollers
Barcelona
Tel: (+34 93) 860 44 20
Fax: (+34 93) 879 10 77
info-es@lemo.com

Madrid Office
Antonio López, 96, 28019 Madrid
Tel: (+34 91) 469 99 19
Fax: (+34 91) 469 99 59

SWEDEN / FINLAND

LEMO Nordic AB

Mariehällsvägen 39A
168 65 Bromma
Tel: (+46 8) 635 60 60
Fax: (+46 8) 635 60 61
info-se@lemo.com

SWITZERLAND

LEMO Verkauf AG

Grundstrasse 22 B
6343 Rotkreuz
Tel: (+41 41) 790 49 40
Fax: (+41 41) 790 49 43
ch.sales@lemo.com

UNITED KINGDOM

LEMO UK Ltd

12-20 North Street
Worthing, West Sussex, BN11 1DU
Tel: (+44 1903) 23 45 43
Fax: (+44 1903) 20 62 31
lemouk@lemo.com

USA

LEMO USA Inc

P.O. Box 2408
Rohnert Park, CA 94927-2408
Tel: (+1 707) 578 88 11
(+1 800) 444 53 66
Fax: (+1 707) 578 08 69
info@lemousa.com

LEMO DISTRIBUTORS

AUSTRALIA, BRAZIL, CZECH REPUBLIC, GREECE, INDIA, ISRAEL,
NEW ZEALAND, PAKISTAN, POLAND, RUSSIA, SOUTH AFRICA,
SOUTH KOREA, TAIWAN, TURKEY, UKRAINE

www.lemo.com





Компания «ЭлектроПласт» предлагает заключение долгосрочных отношений при поставках импортных электронных компонентов на взаимовыгодных условиях!

Наши преимущества:

- Оперативные поставки широкого спектра электронных компонентов отечественного и импортного производства напрямую от производителей и с крупнейших мировых складов;
- Поставка более 17-ти миллионов наименований электронных компонентов;
- Поставка сложных, дефицитных, либо снятых с производства позиций;
- Оперативные сроки поставки под заказ (от 5 рабочих дней);
- Экспресс доставка в любую точку России;
- Техническая поддержка проекта, помощь в подборе аналогов, поставка прототипов;
- Система менеджмента качества сертифицирована по Международному стандарту ISO 9001;
- Лицензия ФСБ на осуществление работ с использованием сведений, составляющих государственную тайну;
- Поставка специализированных компонентов (Xilinx, Altera, Analog Devices, Intersil, Interpoint, Microsemi, Aeroflex, Peregrine, Syfer, Eurofarad, Texas Instrument, Miteq, Cobham, E2V, MA-COM, Hittite, Mini-Circuits, General Dynamics и др.);

Помимо этого, одним из направлений компании «ЭлектроПласт» является направление «Источники питания». Мы предлагаем Вам помощь Конструкторского отдела:

- Подбор оптимального решения, техническое обоснование при выборе компонента;
- Подбор аналогов;
- Консультации по применению компонента;
- Поставка образцов и прототипов;
- Техническая поддержка проекта;
- Защита от снятия компонента с производства.



Как с нами связаться

Телефон: 8 (812) 309 58 32 (многоканальный)

Факс: 8 (812) 320-02-42

Электронная почта: org@eplast1.ru

Адрес: 198099, г. Санкт-Петербург, ул. Калинина, дом 2, корпус 4, литера А.