

SDN™ Series Redundant Options

The SDN Series standard options allow for operation in a wide variety of applications. With the addition of an external redundancy module, the SDN can also be used for true redundant operation including 2N and N+x configurations.

All SDN units include built in current sharing for parallel and redundant operation. The external modules SDN 2.5-20RED and SDN 30/40RED increase the reliability by isolating the supplies and adding more signal options. Paralleling for increased power does not require the use of these modules.

Module Compatibility

Two separate modules are available to provide the maximum flexibility in size, cost and signaling capability. Refer to the chart below for information on which module can be used for each SDN power supply.

Power Rating – A simple Yes or No indication that this module can or cannot handle the power rating of that power supply.

Input/Output Signals – Yes indicates that each power supply would have an independent relay contact to provide power supply status, and the DC bus output from the redundant module has it's own DC OK relay contact. Output only indicates that only the output of the redundant module would have a DC OK relay contact.

Applications

- Process Control
- Remote Location
- Critical Production



Features

- DC OK Relay Contact
- True Isolation
- High availability
- SDN features and quality

Related Products

- SDN™ Series

Redundancy Module Compatibility Chart

		Single Phase SDN Series				
		SDN 2.5–24–100P *	SDN 4–24–100LP *	SDN 5–24–100P SDN 5–24–100C	SDN 10–24–100P SDN 10–24–100C	SDN 20–24–100C
SDN 2.5–20RED	Power Rating	Yes	Yes	Yes	Yes	Yes
	Input / Output Signals	Yes	Yes	Yes	Yes	Yes
SDN 30/40RED	Power Rating	Yes	Yes	Yes	Yes	Yes
	Input / Output Signals	Yes	Yes	Yes	Yes	Yes
		Three Phase SDN Series				
		SDN 5–24–480C	SDN 10–24–480C	SDN 20–24–480CC	SDN 40–24–480C	
SDN 2.5–20RED	Power Rating	Yes	Yes	Yes	No	
	Input / Output Signals	Yes	Yes	Yes	N/A	
SDN 30/40RED	Power Rating	Yes	Yes	Yes	Yes	Yes
	Input / Output Signals	Yes	Yes	Yes	Yes	Yes

* Paralleling will violate Class 2 current limits.

SDN™ Redundant Series Specifications for SDN2.5-20RED and SDN 30/40RED

Catalog Number		
Description	SDN 2.5-20RED	SDN 30/40RED
Concept		
By means of a separate redundancy module, you can interconnect several identical SDN power supply units in a N+1 redundant mode. These external modules decouple the power supply outputs from each other so that, in case of failure, one power supply unit cannot overload the other units. The modules incorporate DC OK relay contacts. The switch on front of the SDN power supply should be placed in parallel mode (not single mode) when power supplies are used with redundant module.		
Electrical Characteristics		
Voltage		
-Nominal Value	24 Vdc	
-Max. Rated	35 V	
Voltage Drop		
-V _{in} -> V _{out}	Typ. 0.6 V	
Current Handling Capacity		
-Maximum Value	20 A	40 A
Inverse Battery Protection	Yes	
Connection	Via captive screw terminals	
-Connector size range	Solid: 16-10 AWG (1.5 - 6 mm ²) Stranded: 16-12 AWG (1.5 - 4 mm ²)	Solid: 16-5 AWG (1.5 - 16 mm ²) Stranded: 16-8 AWG (1.5 - 10 mm ²)
	Note: GND must be connected to module for voltage monitor to operate properly. See Connectors and Wiring diagrams on next page.	
Relay Contacts		
DC Okay Contacts (qty) description	(1) V _{out} "OK" - N.O. & N.C. Contact	(1) V _{out} "OK" - N.O. Contact (2) V _{in} "OK" - N.O. Contact
-Voltage Set Point	> 18 Vdc ±5%	
-Contact Rating	30 Vdc @ 2A / 250 V @ 2A	
DC OK LED	V _{out} "OK" Green LED	
-Voltage Set Point	> 18 Vdc ±5%	
Dimensions		
H x W x D – inches (mm)	4.88 in x 1.97 in x 4.55 in (124.0 mm x 50.0 mm x 116.0 mm)	4.88 in x 2.56 in x 4.55 in (124.0 mm x 65.0 mm x 116.0 mm)
Free Space for Ventilation – inches (mm)	Above/Below: 0.39 in. (10 mm) recommended Left/Right: 0.39 in. (10 mm) recommended	
Weight lbs (kg)	1.4 (625.00)	1.4 (646.00)
General		
Ambient Temperature	Storage: -25°C to +85°C Operation: -10°C to +60°C full power with operation to 70°C possible with a linear derating to half power from 60°C to 70°C (Convection cooling, no forced air required). Operation up to 50% load permissible with sideways or front side up mounting orientation. The relative humidity is < 90% RH, noncondensing.	

Wiring Diagram for SDN 2.5-20RED

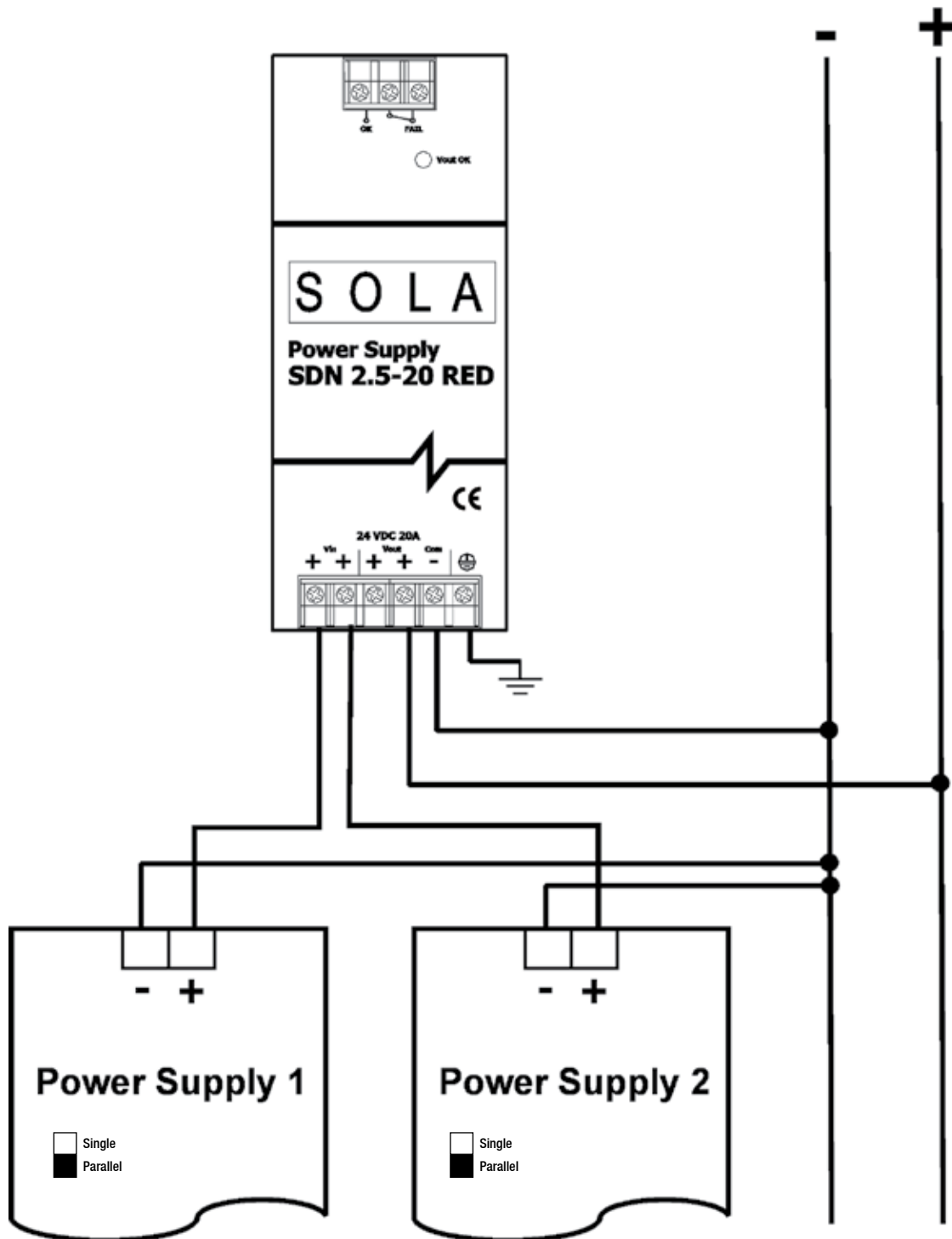

Notes:

1. The Common (marked "COM -") connection to the module is required for voltage monitoring (DC OK Contacts), and is not meant to be part of the current path from the power supply to the load.
2. Protective earth connection only provides protective ground to the metal case of the module. This connection is isolated from the positive and common connections.

Wiring Diagram for SDN 30/40RED

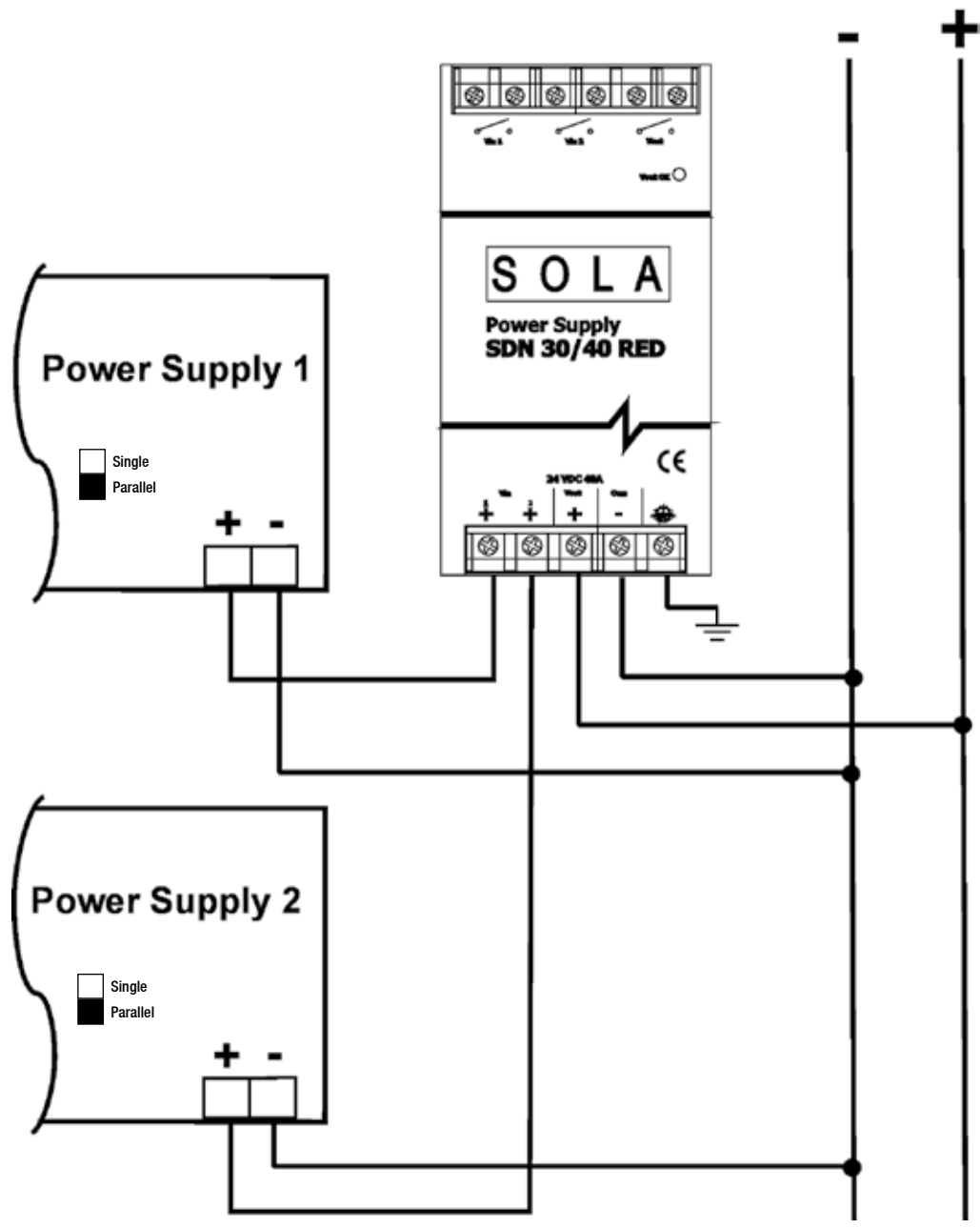

Notes:

1. The Common (marked "COM -") connection to the module is required for voltage monitoring (DC OK Contacts), and is not meant to be part of the current path from the power supply to the load.
2. Protective earth connection only provides protective ground to the metal case of the module. This connection is isolated from the positive and common connections.



Компания «ЭлектроПласт» предлагает заключение долгосрочных отношений при поставках импортных электронных компонентов на взаимовыгодных условиях!

Наши преимущества:

- Оперативные поставки широкого спектра электронных компонентов отечественного и импортного производства напрямую от производителей и с крупнейших мировых складов;
- Поставка более 17-ти миллионов наименований электронных компонентов;
- Поставка сложных, дефицитных, либо снятых с производства позиций;
- Оперативные сроки поставки под заказ (от 5 рабочих дней);
- Экспресс доставка в любую точку России;
- Техническая поддержка проекта, помощь в подборе аналогов, поставка прототипов;
- Система менеджмента качества сертифицирована по Международному стандарту ISO 9001;
- Лицензия ФСБ на осуществление работ с использованием сведений, составляющих государственную тайну;
- Поставка специализированных компонентов (Xilinx, Altera, Analog Devices, Intersil, Interpoint, Microsemi, Aeroflex, Peregrine, Syfer, Eurofarad, Texas Instrument, Miteq, Cobham, E2V, MA-COM, Hittite, Mini-Circuits, General Dynamics и др.);

Помимо этого, одним из направлений компании «ЭлектроПласт» является направление «Источники питания». Мы предлагаем Вам помощь Конструкторского отдела:

- Подбор оптимального решения, техническое обоснование при выборе компонента;
- Подбор аналогов;
- Консультации по применению компонента;
- Поставка образцов и прототипов;
- Техническая поддержка проекта;
- Защита от снятия компонента с производства.



Как с нами связаться

Телефон: 8 (812) 309 58 32 (многоканальный)

Факс: 8 (812) 320-02-42

Электронная почта: org@eplast1.ru

Адрес: 198099, г. Санкт-Петербург, ул. Калинина, дом 2, корпус 4, литера А.