

IS31FL3729

16x8/15x9 MATRIX LED DRIVER

November 2019

GENERAL DESCRIPTION

The IS31FL3729 is a general purpose 16x8 or 15x9 LED Matrix programmed via 1MHz I2C compatible interface. Each LED can be dimmed individually with 8-bit PWM data, and each CSx has 8-bit DC scaling (Color Calibration) data which allowing 256 steps of linear PWM dimming for each dot and 256 steps of DC current adjustable level for each CSx.

Additionally each LED open and short state can be detected, IS31FL3729 store the open or short information in Open-Short Registers. The Open-Short Registers allowing MCU to read out via I2C compatible interface. Inform MCU whether there are LEDs open or short and the locations of open or short LEDs.

The IS31FL3729 operates from 2.7V to 5.5V and features a very low shutdown and operational current.

IS31FL3729 is available in QFN-32 (4mmx4mm) and eTQFP-32 packages. It operates from 2.7V to 5.5V over the temperature range of -40°C to +125°C.

FEATURES

- Supply voltage range: 2.7V to 5.5V
- 16 current sinks
- Support 16xn (n=1~8), 15x9 LED matrix configurations
- Individual 256 PWM control steps
- 256 DC current steps for each CSx
- 64 global current steps
- SDB rising edge reset I2C module
- 32kHz PWM frequency
- 1MHz I2C-compatible interface
- Individual open and short error detect function
- PWM 180 degree phase shift
- Spread spectrum
- De-ghost
- QFN-32 (4mmx4mm) and eTQFP-32 packages

APPLICATIONS

- White goods LED display panel.
- IOT device

TYPICAL APPLICATION CIRCUIT

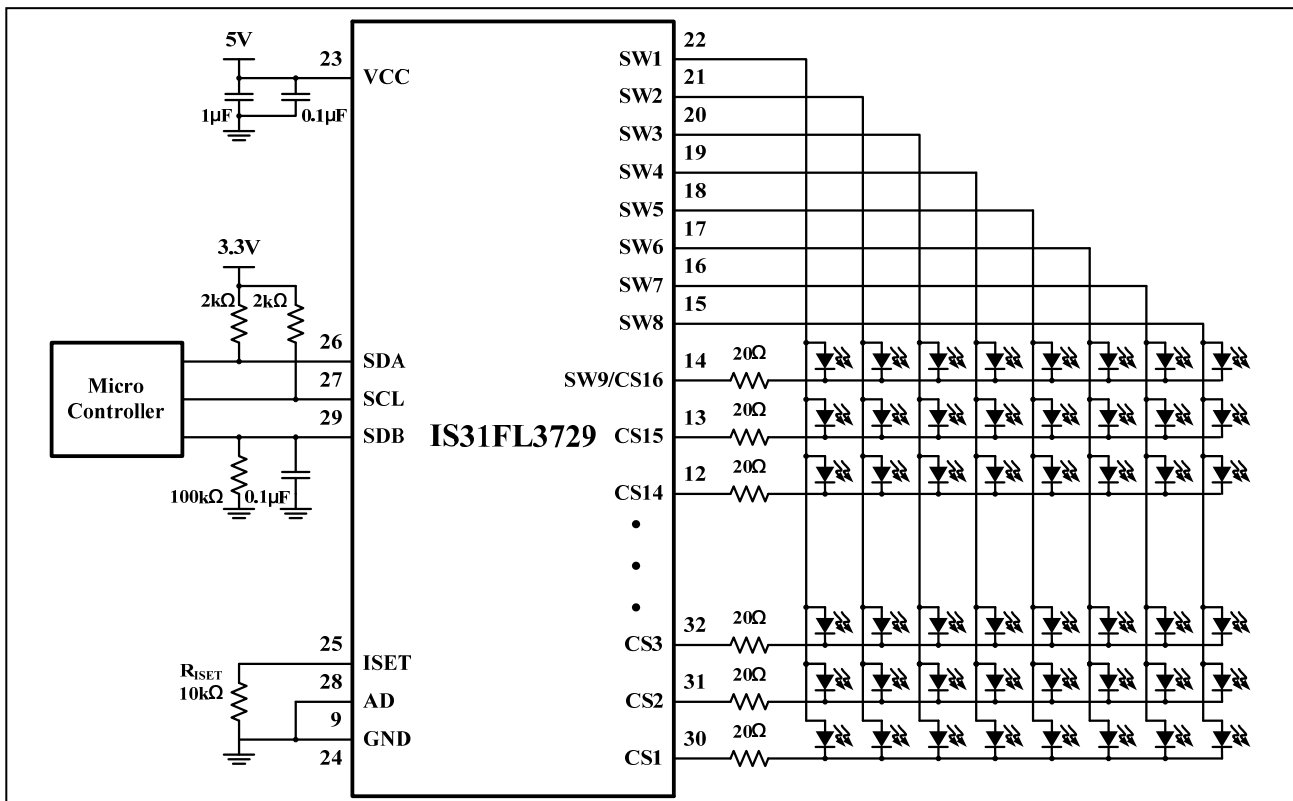

Figure 1 Typical Application Circuit (16x8)

IS31FL3729

TYPICAL APPLICATION CIRCUIT (CONTINUED)

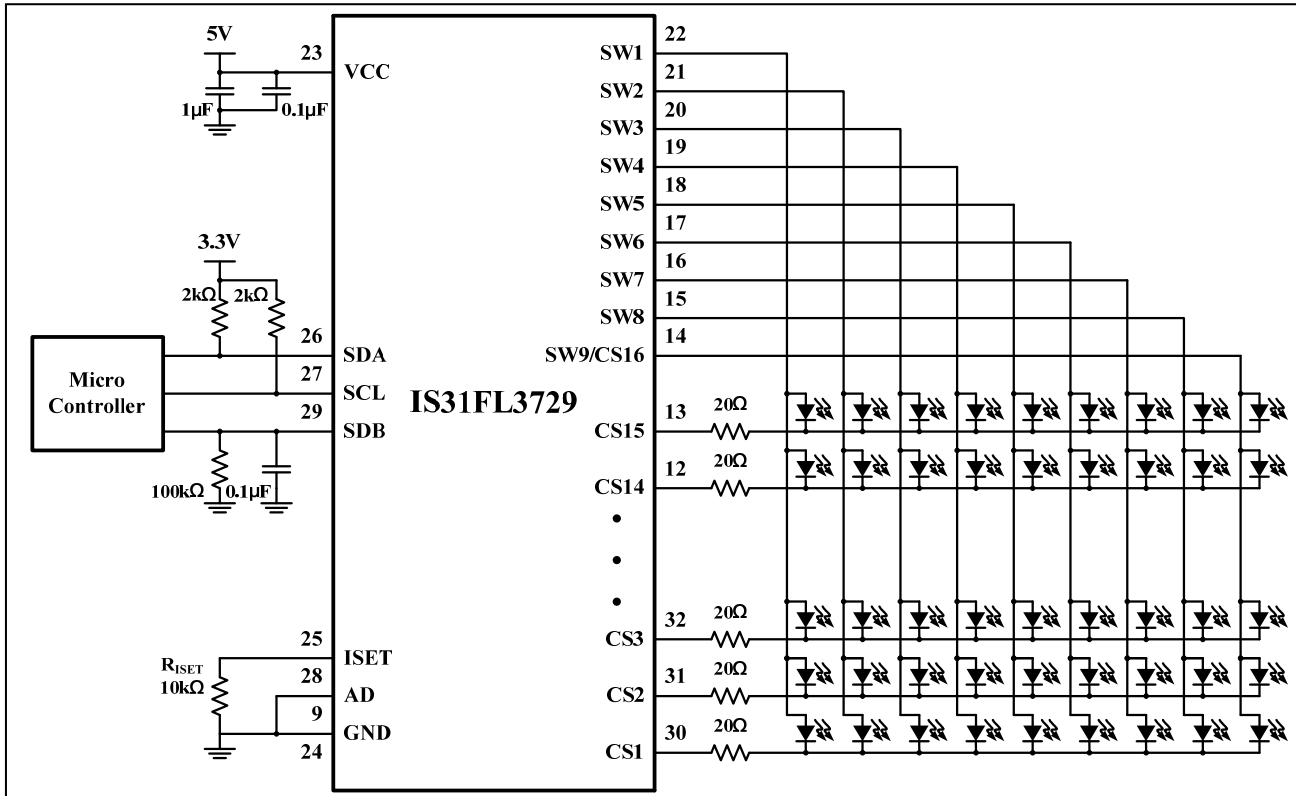

Figure 2 Typical Application Circuit (15x9)

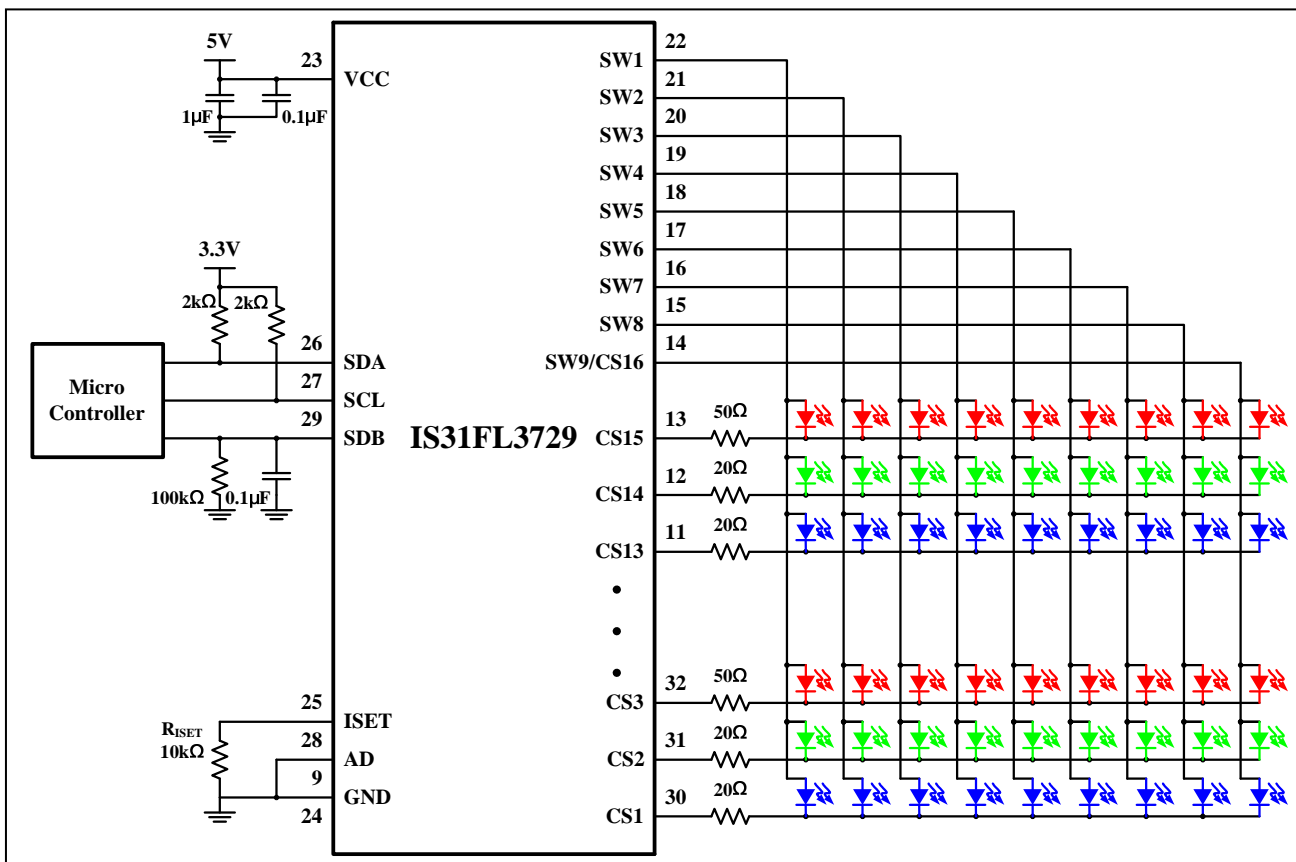
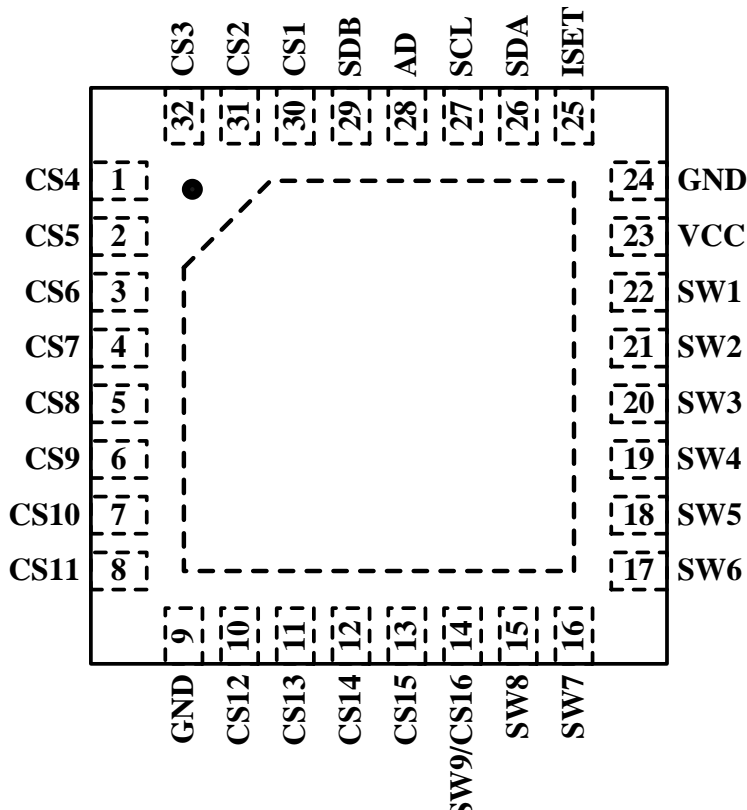
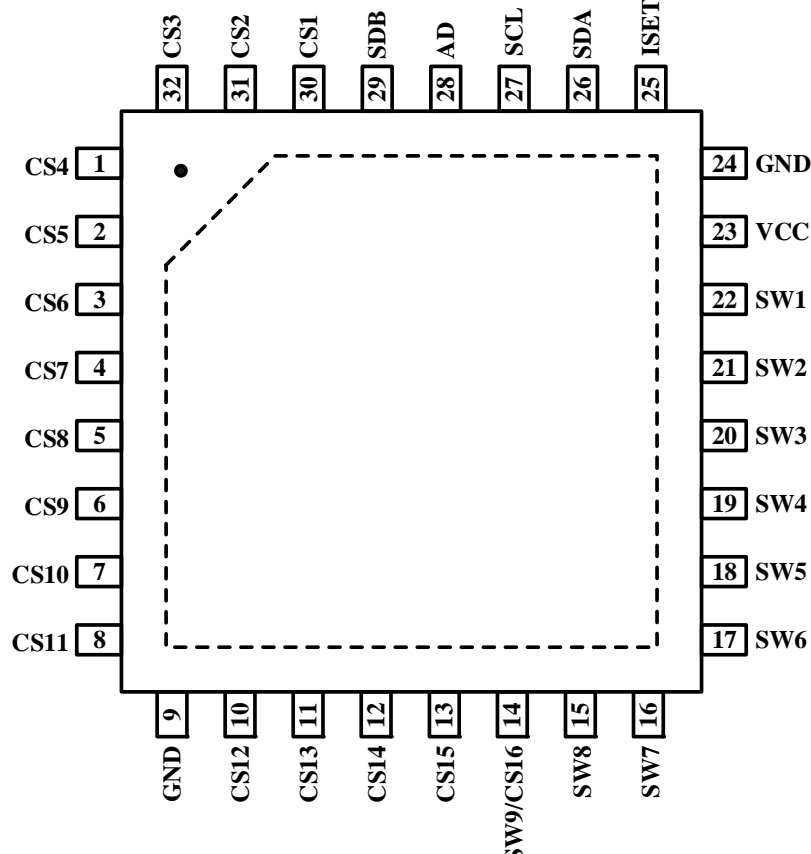

Figure 3 Typical Application Circuit (45 RGBs)

IS31FL3729

PIN CONFIGURATION

Package	Pin Configuration (Top View)
QFN-32	 <p>Pin Configuration (Top View) for QFN-32 package:</p> <ul style="list-style-type: none"> Top edge (pins 25-32): CS3 (32), CS2 (31), CS1 (30), SDB (29), AD (28), SCL (27), SDA (26), ISET (25) Right edge (pins 17-24): GND (24), VCC (23), SW1 (22), SW2 (21), SW3 (20), SW4 (19), SW5 (18), SW6 (17) Bottom edge (pins 9-16): GND (9), CS12 (10), CS13 (11), CS14 (12), CS15 (13), SW9/CS16 (14), SW8 (15), SW7 (16) Left edge (pins 1-8): CS4 (1), CS5 (2), CS6 (3), CS7 (4), CS8 (5), CS9 (6), CS10 (7), CS11 (8)
eTQFP-32	 <p>Pin Configuration (Top View) for eTQFP-32 package:</p> <ul style="list-style-type: none"> Top edge (pins 25-32): CS3 (32), CS2 (31), CS1 (30), SDB (29), AD (28), SCL (27), SDA (26), ISET (25) Right edge (pins 17-24): GND (24), VCC (23), SW1 (22), SW2 (21), SW3 (20), SW4 (19), SW5 (18), SW6 (17) Bottom edge (pins 9-16): GND (9), CS12 (10), CS13 (11), CS14 (12), CS15 (13), SW9/CS16 (14), SW8 (15), SW7 (16) Left edge (pins 1-8): CS4 (1), CS5 (2), CS6 (3), CS7 (4), CS8 (5), CS9 (6), CS10 (7), CS11 (8)

IS31FL3729

PIN DESCRIPTION

No.	Pin	Description
1~8, 10~13	CS4~CS15	Current sinks output.
9,24	GND	Ground.
14	SW9/CS16	Switch power source / current sinks output.
15~22	SW8~SW1	Switch power source.
23	VCC	Power supply.
25	ISET	Current setting pin.
26	SDA	Serial data.
27	SCL	Serial clock.
28	AD	I2C Address setting.
29	SDB	Shutdown the chip when pull to low.
30~32	CS1~CS3	Current sinks output.
	Thermal Pad	Need to connect to GND pins.

IS31FL3729

ORDERING INFORMATION

Industrial Range: -40°C to +125°C

Order Part No.	Package	QTY/Reel
IS31FL3729-QFLS4-TR	QFN-32, Lead-free	2500
IS31FL3729-TQLS4-TR	eTQFP-32, Lead-free	

Copyright © 2019 Integrated Silicon Solution, Inc. All rights reserved. ISSI reserves the right to make changes to this specification and its products at any time without notice. ISSI assumes no liability arising out of the application or use of any information, products or services described herein. Customers are advised to obtain the latest version of this device specification before relying on any published information and before placing orders for products.

Integrated Silicon Solution, Inc. does not recommend the use of any of its products in life support applications where the failure or malfunction of the product can reasonably be expected to cause failure of the life support system or to significantly affect its safety or effectiveness. Products are not authorized for use in such applications unless Integrated Silicon Solution, Inc. receives written assurance to its satisfaction, that:

- a.) the risk of injury or damage has been minimized;
- b.) the user assume all such risks; and
- c.) potential liability of Integrated Silicon Solution, Inc is adequately protected under the circumstances

IS31FL3729

ABSOLUTE MAXIMUM RATINGS

Supply voltage, V_{CC}	-0.3V ~ +6.0V
Voltage at any input pin	-0.3V ~ $V_{CC}+0.3V$
Maximum junction temperature, T_{JMAX}	+150°C
Storage temperature range, T_{STG}	-65°C ~ +150°C
Operating temperature range, $T_A=T_J$	-40°C ~ +125°C
Package thermal resistance, junction to ambient (4 layer standard test PCB based on JESD 51-2A), θ_{JA}	52.2°C/W (QFN) 36.1°C/W (eTQFP)
ESD (HBM)	±8kV
ESD (CDM)	±750V

Note 1: Stresses beyond those listed under “Absolute Maximum Ratings” may cause permanent damage to the device. These are stress ratings only and functional operation of the device at these or any other condition beyond those indicated in the operational sections of the specifications is not implied. Exposure to absolute maximum rating conditions for extended periods may affect device reliability.

ELECTRICAL CHARACTERISTICS

The following specifications apply for $V_{CC} = 5V$, $T_A = 25^\circ C$, unless otherwise noted.

Symbol	Parameter	Conditions	Min.	Typ.	Max.	Unit
V_{CC}	Supply voltage		2.7		5.5	V
I_{CC}	Quiescent power supply current	$V_{SDB}=V_{CC}$, all LEDs off		2	3	mA
I_{SD}	Shutdown current	$V_{SDB}=0V$		3	5	μA
		$V_{SDB}=V_{CC}$, Configuration Register written “0000 0000”		3	5	
I_{OUT}	Maximum constant current of CSx	$R_{ISET}=10k\Omega$, GCC= “100 0000” SL=0xFF		35		mA
I_{LED}	Average current on each LED $I_{LED} = I_{OUT(PEAK)}/Duty$	$R_{ISET}=10k\Omega$, GCC= “100 0000” SL=0xFF, n=8, Duty=1/8.29		4.22		mA
V_{HR}	Current switch headroom voltage SWx	$I_{SWITCH}=600mA$, $R_{ISET}=10k\Omega$, GCC= “100 0000”, SL=0xFF		500	550	mV
	Current sink headroom voltage CSx	$I_{SINK}=34mA$, $R_{ISET}=10k\Omega$, GCC= “100 0000”, SL=0xFF		400	500	
t_{SCAN}	Period of scanning			30		μs
t_{NOL1}	Non-overlap blanking time during scan, the SWx and CSy are all off during this time			0.8		μs
t_{NOL2}	Delay total time for CS1 to CS16, during this time, the SWx is on but CSx is not all turned on			0.27		μs

Logic Electrical Characteristics (SDA, SCL, AD, SDB)

V_{IL}	Logic “0” input voltage	$V_{CC}=2.7V\sim 5.5V$, LGC= “0”	GND		0.4	V
V_{IH}	Logic “1” input voltage	$V_{CC}=2.7V\sim 5.5V$, LGC= “0”	1.4		V_{CC}	V
V_{IL}	Logic “0” input voltage	$V_{CC}=2.7V\sim 5.5V$, LGC= “1”	GND		0.6	V
V_{IH}	Logic “1” input voltage	$V_{CC}=2.7V\sim 5.5V$, LGC= “1”	2.4		V_{CC}	V
V_{HYS}	Input schmitt trigger hysteresis	$V_{CC}=3.6V$, LGC= “0”, LGC= “1”		0.2		V
I_{IL}	Logic “0” input current	SDB=L, $V_{INPUT}=L$ (Note 2)		5		nA
I_{IH}	Logic “1” input current	SDB=L, $V_{INPUT}=H$ (Note 2)		5		nA

IS31FL3729

DIGITAL INPUT I2C SWITCHING CHARACTERISTICS (NOTE 2)

Symbol	Parameter	Fast Mode			Fast Mode Plus			Units
		Min.	Typ.	Max.	Min.	Typ.	Max.	
f_{SCL}	Serial-clock frequency	-		400	-		1000	kHz
t_{BUF}	Bus free time between a STOP and a START condition	1.3		-	0.5		-	μ s
$t_{HD, STA}$	Hold time (repeated) START condition	0.6		-	0.26		-	μ s
$t_{SU, STA}$	Repeated START condition setup time	0.6		-	0.26		-	μ s
$t_{SU, STO}$	STOP condition setup time	0.6		-	0.26		-	μ s
$t_{HD, DAT}$	Data hold time	-		-	-		-	μ s
$t_{SU, DAT}$	Data setup time	100		-	50		-	ns
t_{LOW}	SCL clock low period	1.3		-	0.5		-	μ s
t_{HIGH}	SCL clock high period	0.7		-	0.26		-	μ s
t_R	Rise time of both SDA and SCL signals, receiving	-		300	-		120	ns
t_F	Fall time of both SDA and SCL signals, receiving	-		300	-		120	ns

Note 2: Guaranteed by design.

IS31FL3729

FUNCTIONAL BLOCK DIAGRAM

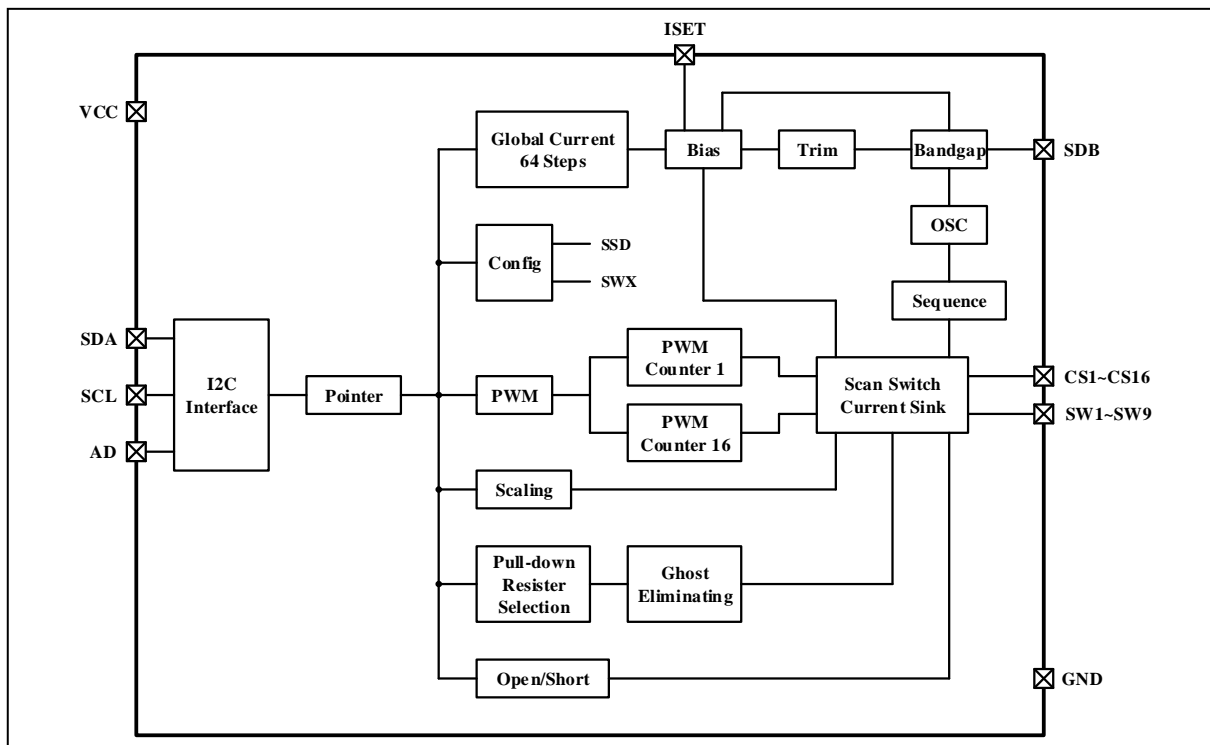

IS31FL3729

DETAILED DESCRIPTION

I2C INTERFACE

IS31FL3729 uses a serial bus, which conforms to the I2C protocol, to control the chip's functions with two wires: SCL and SDA. The IS31FL3729 has a 7-bit slave address (A7:A1), followed by the R/W bit, A0. Set A0 to "0" for a write command and set A0 to "1" for a read command. The value of bits A1 and A2 are decided by the connection of the AD pin.

Table 1 Slave Address

AD	A7:A3	A2:A1	A0
GND	01101	00	0/1
SCL		01	
SDA		10	
VCC		11	

AD connected to GND, A2:A1=00;

AD connected to VCC, A2:A1=11;

AD connected to SCL, A2:A1=01;

AD connected to SDA, A2:A1=10;

The SCL line is uni-directional. The SDA line is bi-directional (open-collector) with a pull-up resistor (typically 400kHz I2C with 4.7kΩ, 1MHz I2C with 2kΩ). The maximum clock frequency specified by the I2C standard is 1MHz. In this discussion, the master is the microcontroller and the slave is the IS31FL3729.

The timing diagram for the I2C is shown in Figure 4. The SDA is latched in on the stable high level of the SCL. When there is no interface activity, the SDA line should be held high.

The "START" signal is generated by lowering the SDA signal while the SCL signal is high. The start signal will alert all devices attached to the I2C bus to check the incoming address against their own chip address.

The 8-bit chip address is sent next, most significant bit first. Each address bit must be stable while the SCL level is high.

After the last bit of the chip address is sent, the master checks for the IS31FL3729's acknowledge. The master

releases the SDA line high (through a pull-up resistor). Then the master sends an SCL pulse. If the IS31FL3729 has received the address correctly, then it holds the SDA line low during the SCL pulse. If the SDA line is not low, then the master should send a "STOP" signal (discussed later) and abort the transfer.

Following acknowledge of IS31FL3729, the register address byte is sent, most significant bit first. IS31FL3729 must generate another acknowledge indicating that the register address has been received.

Then 8-bit of data byte are sent next, most significant bit first. Each data bit should be valid while the SCL level is stable high. After the data byte is sent, the IS31FL3729 must generate another acknowledge to indicate that the data was received.

The "STOP" signal ends the transfer. To signal "STOP", the SDA signal goes high while the SCL signal is high.

ADDRESS AUTO INCREMENT

To write multiple bytes of data into IS31FL3729, load the address of the data register that the first data byte is intended for. During the IS31FL3729 acknowledge of receiving the data byte, the internal address pointer will increment by one. The next data byte sent to IS31FL3729 will be placed in the new address, and so on. The auto increment of the address will continue as long as data continues to be written to IS31FL3729 (Figure 7).

READING OPERATION

Most of the registers can be read.

To read the register, after I2C start condition, the bus master must send the IS31FL3729 device address with the $\overline{R/W}$ bit set to "0", followed by the register address which determines which register is accessed. Then restart I2C, the bus master should send the IS31FL3729 device address with the $\overline{R/W}$ bit set to "1". Data from the register defined by the command byte is then sent from the IS31FL3729 to the master (Figure 8).

IS31FL3729

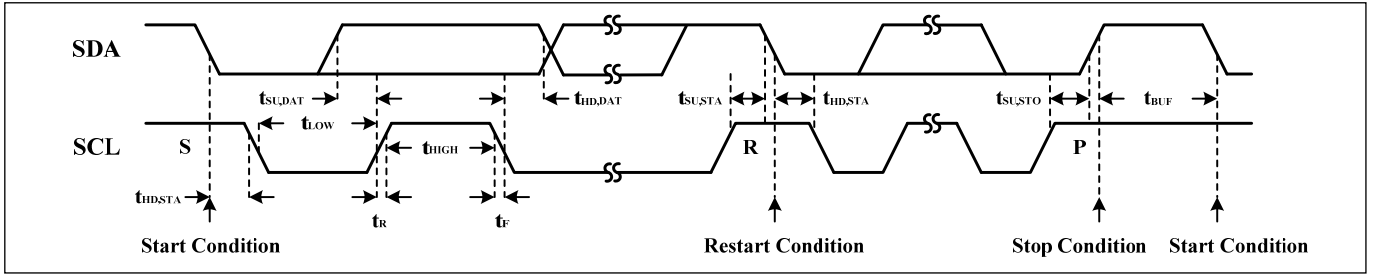

Figure 4 I2C Interface Timing

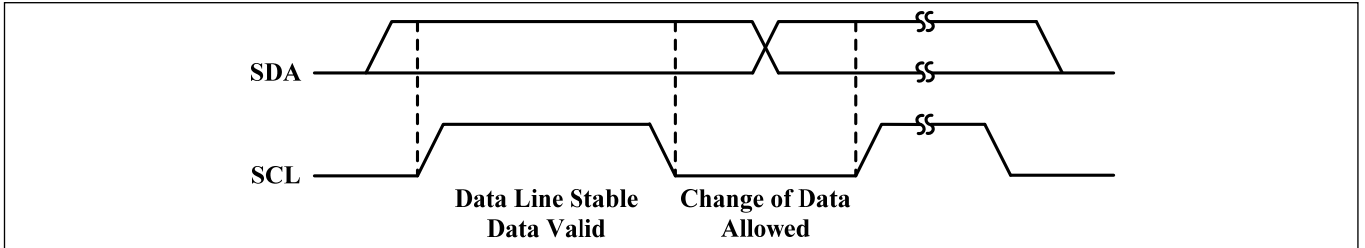

Figure 5 I2C Bit Transfer

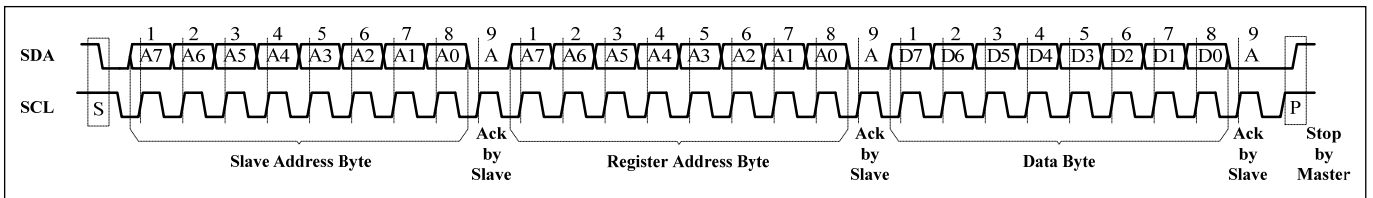

Figure 6 I2C Writing to IS31FL3729 (Typical)

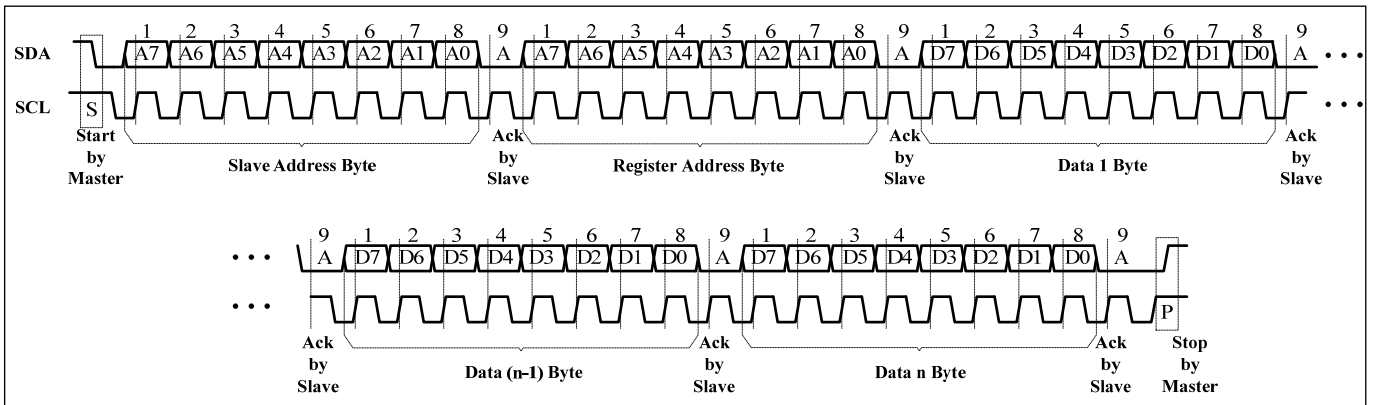

Figure 7 I2C Writing to IS31FL3729 (Automatic Address Increment)

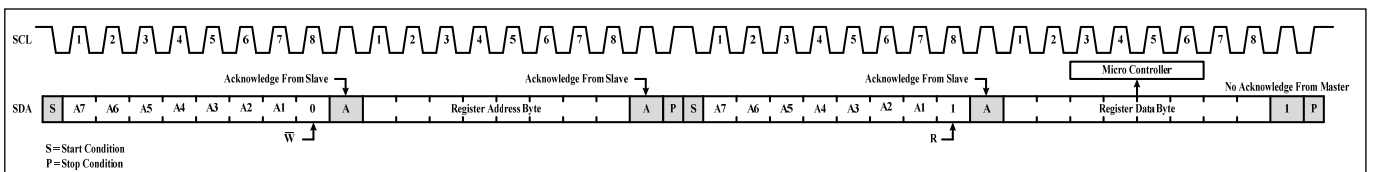

Figure 8 I2C Reading from IS31FL3729

IS31FL3729

Table 5 Register Definition

Address	Name	Function	Table	R/W	Default
01h~8Fh	PWM Register	Set PWM value for LED	6	R/W	0000 0000
90h~9Fh	Scaling Register	Control the DC output current of each CSy	7	R/W	0000 0000
A0h	Configuration Register	Configure the operation mode	8	R/W	0000 0000
A1h	Global Current Control Register	Set the global current	9	R/W	0000 0000
B0h	Pull Down/Up Resistor Selection Register	Set the pull down resistor for SWx and pull up resistor for CSy	10	R/W	0011 0011
B1h	Spread Spectrum Register	Spread spectrum function enable	11	R/W	0000 0000
B2h	PWM Frequency Register	Set the PWM frequency	12	R/W	0000 0001
B3h~C4h	Open/Short Register	Store the open or short information	13	R/W	0000 0000
CFh	Reset Register	Reset all register to POR state	-	W	0000 0000

IS31FL3729

PWM Register

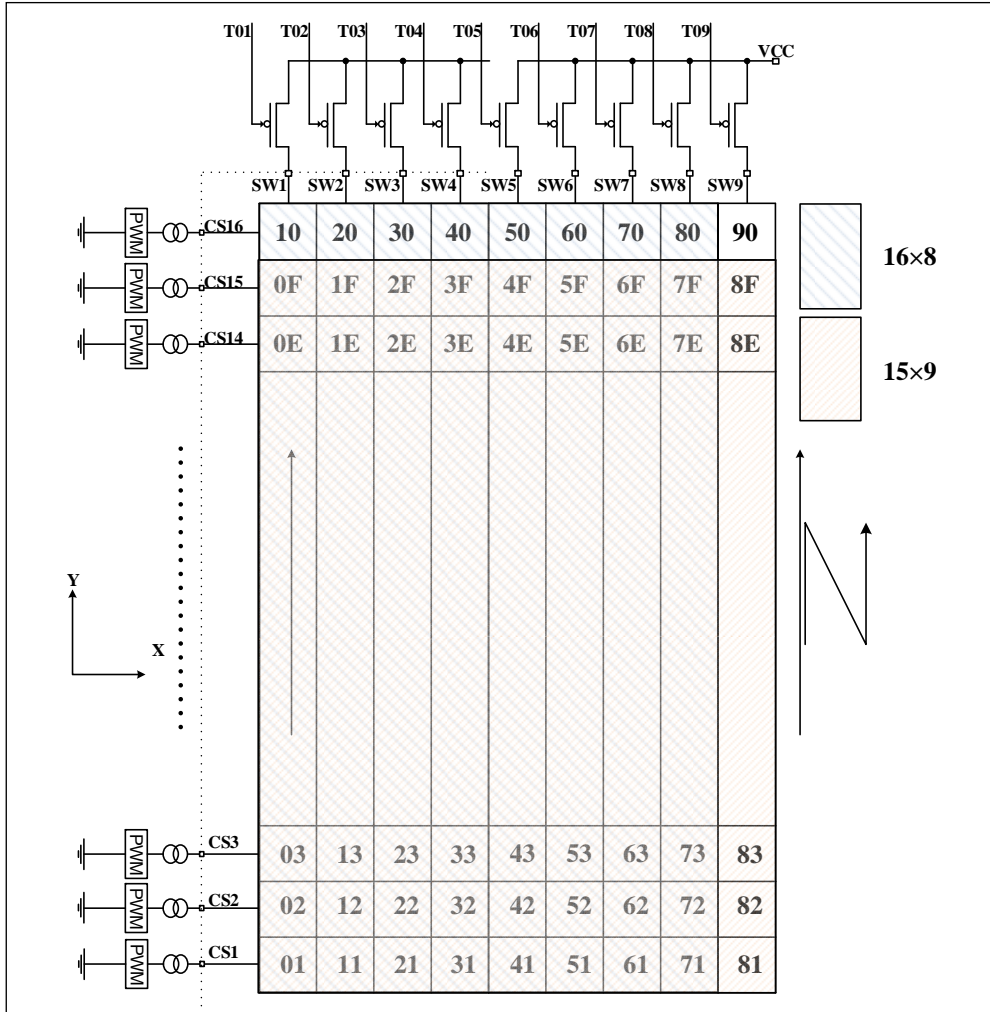

Figure 9 PWM Register

Table 6 01h~8Fh PWM Register

Bit	D7:D0
Name	PWM
Default	0000 0000

Each dot has a byte to modulate the PWM duty in 256 steps.

The value of the PWM Registers decides the average current of each LED noted I_{LED} .

I_{LED} computed by Formula (1):

$$I_{LED} = \frac{PWM}{256} \times I_{OUT(PEAK)} \times Duty \quad (1)$$

$$PWM = \sum_{n=0}^7 D[n] \cdot 2^n$$

Where Duty is the duty cycle of SWx, when n=8,

$$Duty = \frac{30\mu s}{(30\mu s + 0.8\mu s + 0.27\mu s)} \times \frac{1}{9} = \frac{1}{9.32} \quad (2)$$

When n=8,

$$Duty = \frac{30\mu s}{(30\mu s + 0.8\mu s + 0.27\mu s)} \times \frac{1}{8} = \frac{1}{8.29} \quad (2)$$

I_{OUT} is the output current of CSy (y=1~16),

$$I_{OUT(PEAK)} = \frac{342}{R_{ISET}} \times \frac{GCC}{64} \times \frac{SL}{256} \quad (3)$$

GCC is the Global Current Control Register (A1h) value, SL is the Scaling Register value as Table 9 and R_{ISET} is the external resistor of ISET pin. D[n] stands for the individual bit value, 1 or 0, in location n.

For example: if D7:D0=1011 0101 (0xB5, 181), GCC= 100 0000, R_{ISET} =10kΩ, SL=1111 1111:

$$I_{LED} = \frac{342}{10\text{ k}\Omega} \times \frac{64}{64} \times \frac{255}{256} \times \frac{1}{9.32} \times \frac{181}{256}$$

IS31FL3729

Scaling Register

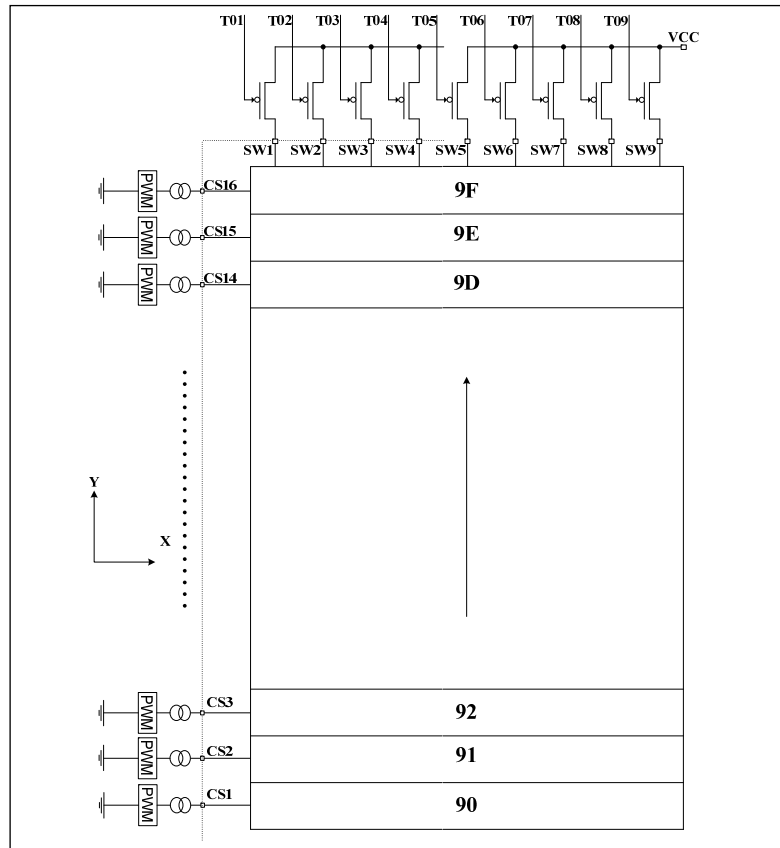

Figure 10 Scaling Register

Table 7 90h ~ 9Fh Scaling Register

Bit	D7:D0
Name	SL
Default	0000 0000

Scaling register control the DC output current of each CSy. Each CSy has a byte to modulate the scaling in 256 steps.

The value of the Scaling Register decides the peak current of each LED noted $I_{OUT(PEAK)}$.

$I_{OUT(PEAK)}$ computed by Formula (3):

$$I_{OUT(PEAK)} = \frac{342}{R_{ISET}} \times \frac{GCC}{64} \times \frac{SL}{256} \quad (3)$$

$$SL = \sum_{n=0}^7 D[n] \cdot 2^n$$

I_{OUT} is the output current of CSy (y=1~16), GCC is the Global Current Control Register (A1h) value and R_{ISET} is the external resistor of R_{ISET} pin. D[n] stands for the individual bit value, 1 or 0, in location n.

For example: if $R_{ISET}=10k\Omega$, $GCC=100\ 0000$, $SL=0111\ 1111$:

$$SL = \sum_{n=0}^7 D[n] \cdot 2^n = 127$$

$$I_{OUT} = \frac{342}{10k\Omega} \times \frac{64}{64} \times \frac{127}{256} = 16.9mA$$

$$I_{LED} = 16.9mA \times \frac{1}{9.27} \times \frac{PWM}{256}$$

IS31FL3729

Table 8 A0h Configuration Register

Bit	D7:D4	D3	D2:D1	D0
Name	SWS	LGC	OSDE	SSD
Default	0001	0	00	0

The Configuration Register sets operating mode of IS31FL3729.

SSD	Software Shutdown Control
0	Software shutdown
1	Normal operation
OSDE	Open Short Detection Enable
00	Disable open/short detection
01/11	Enable open detection
10	Enable short detection
LGC	H/L logic
0	1.4V/0.4V
1	2.4V/0.6V
SWS	SWx Setting
0000	n=9, SW1~SW9, 9SW×15CS matrix
0001	n=8, SW1~SW8, 8SW×16CS matrix
0010	n=7, SW1~SW7, 7SW×16CS matrix, SW8 no-active
0011	n=6, SW1~SW6, 6SW×16CS matrix, SW7~SW8 no-active
0100	n=5, SW1~SW5, 5SW×16CS matrix, SW6~SW8 no-active
0101	n=4, SW1~SW4, 4SW×16CS matrix, SW5~SW8 no-active
0110	n=3, SW1~SW3, 3SW×16CS matrix, SW4~SW8 no-active
0111	n=2, SW1~SW2, 2SW×16CS matrix, SW3~SW8 no-active
1000	SW1~SW9 with same phase, all on.
Others	SW1~SW9, SW1~SW9, 9SW×15CS matrix

When OSDE set to “01”, open detection will be trigger once, the user could trigger open detection again by set OSDE from “00” to “01”.

When OSDE set “10”, short detection will be trigger once, the user could trigger short detection again by set OSDE from “00” to “10”.

When SSD is “0”, IS31FL3729 works in software shutdown mode and to normal operate the SSD bit should set to “1”.

SWS control the duty cycle of the SWx, default mode is 1/8.

Table 9 A1h Global Current Control Register

Bit	D7	D6:D0
Name	-	GCC
Default	0	000 0000

The Global Current Control Register modulates all CSy (y=1~16) DC current which is noted as I_{OUT} in 65 steps, maximum GCC is “100 0000”, if GCC> “1000000”, GCC= “100 0000”.

I_{OUT} is computed by the Formula (3):

$$I_{OUT(PEAK)} = \frac{342}{R_{ISET}} \times \frac{GCC}{64} \times \frac{SL}{256}$$

$$GCC = \sum_{n=0}^7 D[n] \cdot 2^n$$

Where D[n] stands for the individual bit value, 1 or 0, in location n.

Table 10 B0h Pull Down/Up Resistor Selection Register

Bit	D7	D6:D4	D3	D2:D0
Name	PHC	SWPDR	-	CSPUR
Default	0	011	0	011

Set pull down resistor for SWx and pull up resistor for CSy.

PHC	Phase choice
0	0 degree phase delay
1	180 degree phase delay
SWPDR	SWx Pull down Resistor Selection Bit
000	No pull down resistor
001	0.5kΩ only in SWx off time
010	1.0kΩ only in SWx off time
011	2.0kΩ only in SWx off time
100	1.0kΩ all the time
101	2.0kΩ all the time
110	4.0kΩ all the time
111	8.0kΩ all the time
CSPUR	CSy Pull up Resistor Selection Bit
000	No pull up resistor
001	0.5kΩ only in CSx off time
010	1.0kΩ only in CSx off time
011	2.0kΩ only in CSx off time
100	1.0kΩ all the time
101	2.0kΩ all the time
110	4.0kΩ all the time
111	8.0kΩ all the time

IS31FL3729

Table 11 B1h Spread Spectrum Register

Bit	D7:D6	D4	D3:D2	D1:D0
Name	-	SSP	RNG	CLT
Default	00	0	00	00

When SSP enable, the spread spectrum function will be enabled and the RNG & CLT bits will adjust the range and cycle time of spread spectrum function.

SSP Spread spectrum function enable
 0 Disable
 1 Enable

RNG Spread spectrum range
 00 ±5%
 01 ±15%
 10 ±24%
 11 ±34%

CLT Spread spectrum cycle time
 00 1980µs
 01 1200µs
 10 820µs
 11 660µs

Table 12 B2h PWM Frequency

Bit	D7:D3	D2:D0
Name	-	PWMF
Default	00000	001

Set the PWM frequency, default is 32 kHz. In order to avoid LED display flicker, it is recommended PWM frequency ÷ n is higher than 100Hz, so when PWM frequency is 0.5 kHz, n cannot be more than 4, when PWM frequency is 0.25 kHz, n cannot be more than 2.

PWMF PWM frequency setting
 000 55kHz
 001 32kHz
 010 4kHz
 011 2kHz
 100 1kHz
 101 0.5kHz, (n≤4)
 110 0.25kHz, (n≤2)
 111 80kHz

Table 13 B3h~C4h Open/Short Register (Read Only)

Bit	D7:D0
Name	CS16:CS09, CS08:CS01
Default	0000 0000

When OSDE (A0h) is set to "01", open detection will be trigger once, and the open information will be stored at B3h~C4h.

When OSDE (A0h) set to "10", short detection will be trigger once, and the short information will be stored at B3h~C4h.

Before set OSDE, the GCC should set to 0x01.

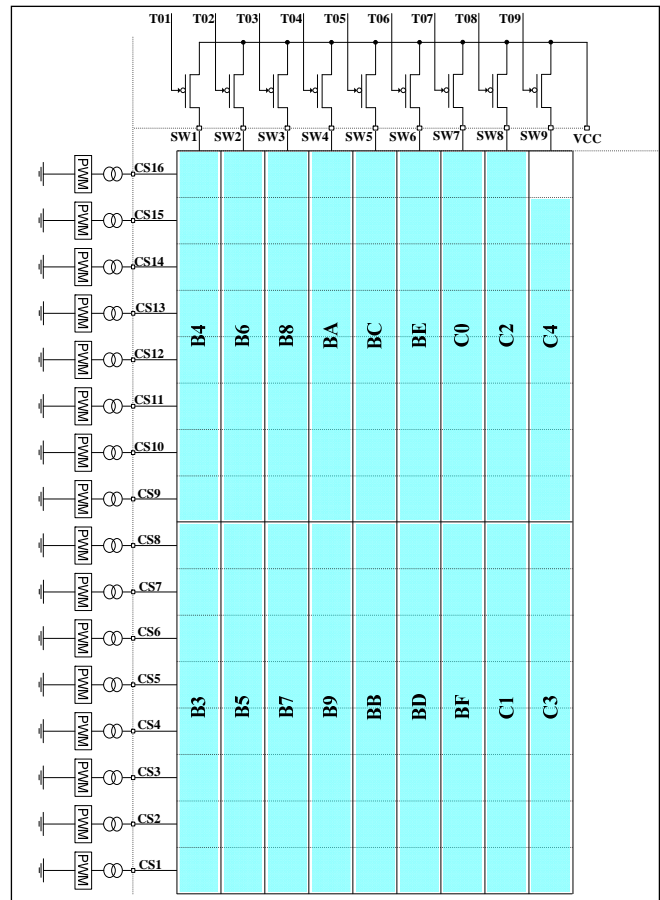

Figure 11 Open/Short Register

CFh Reset Register

Once user writes the Reset Register with 0xAE, IS31FL3729 will reset all the IS31FL3729 registers to their default value. On initial power-up, the IS31FL3729 registers are reset to their default values for a blank display.

APPLICATION INFORMATION

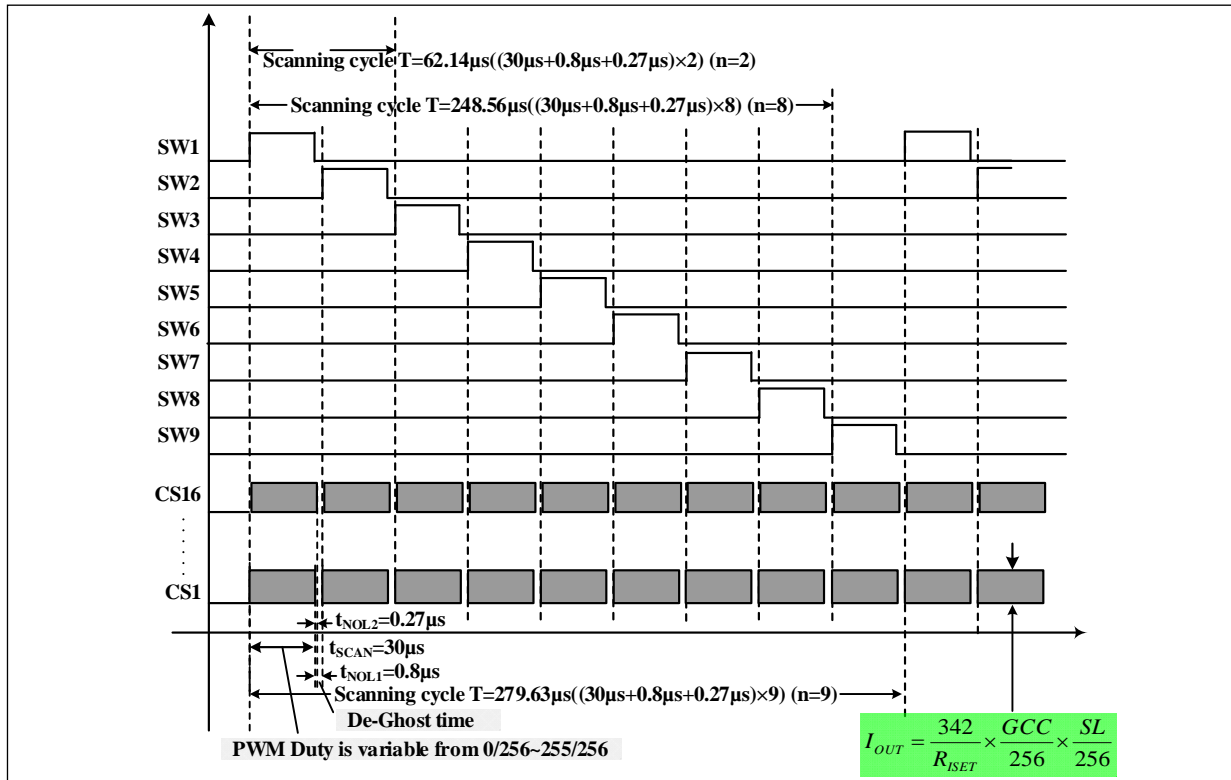

Figure 12 Scanning Timing

SCANNING TIMING

As shown in Figure above, the SW1~SW9 is turned on by serial, LED is driven 15 by 9 within the SWx (x=1~9) on time (SWx, x=1~9 is source and it is high when LED on), including the non-overlap blanking time during scan, the duty cycle of SWx (active high, x=1~9) is (n=9):

$$Duty = \frac{30\mu s}{(30\mu s + 0.8\mu s + 0.27\mu s)} \times \frac{1}{9} = \frac{1}{9.32} \quad (2)$$

Or (n=8):

$$Duty = \frac{30\mu s}{(30\mu s + 0.8\mu s + 0.27\mu s)} \times \frac{1}{8} = \frac{1}{8.29} \quad (2)$$

Where 30µs is t_{SCAN} , the period of scanning and 0.8µs is t_{NOL1} , the non-overlap time and 0.27µs is the CSx delay time.

PWM CONTROL

After setting the I_{OUT} and GCC, the brightness of each LEDs (LED average current (I_{LED})) can be modulated with 256 steps by PWM Register, as described in Formula (1).

$$I_{LED} = \frac{PWM}{256} \times I_{OUT(PEAK)} \times Duty \quad (1)$$

Where PWM is PWM Registers' (01h~8Fh) data showing in Table 6.

For example, in Figure 1, if $R_{ISET} = 10k\Omega$, PWM= 1011 0101 (0xB5, 181), and GCC= 100 0000, SL= 1111 1111, then,

$$I_{OUT(PEAK)} = \frac{342}{R_{ISET}} \times \frac{GCC}{64} \times \frac{SL}{256}$$

$$I_{LED} = \frac{342}{10k\Omega} \times \frac{64}{64} \times \frac{255}{256} \times \frac{1}{9.32} \times \frac{181}{256} \quad (n=9)$$

Writing new data continuously to the registers can modulate the brightness of the LEDs to achieve a breathing effect.

GAMMA CORRECTION

In order to perform a better visual LED breathing effect we recommend using a gamma corrected PWM value to set the LED intensity. This results in a reduced number of steps for the LED intensity setting, but causes the change in intensity to appear more linear to the human eye.

Gamma correction, also known as gamma compression or encoding, is used to encode linear luminance to match the non-linear characteristics of display. Since the IS31FL3729 can modulate the brightness of the LEDs with 256 steps, a gamma correction function can be applied when computing each subsequent LED intensity setting such that the changes in brightness matches the human eye's brightness curve.

IS31FL3729

Table 12 32 Gamma Steps with 256 PWM Steps

C(0)	C(1)	C(2)	C(3)	C(4)	C(5)	C(6)	C(7)
0	1	2	4	6	10	13	18
C(8)	C(9)	C(10)	C(11)	C(12)	C(13)	C(14)	C(15)
22	28	33	39	46	53	61	69
C(16)	C(17)	C(18)	C(19)	C(20)	C(21)	C(22)	C(23)
78	86	96	106	116	126	138	149
C(24)	C(25)	C(26)	C(27)	C(28)	C(29)	C(30)	C(31)
161	173	186	199	212	226	240	255

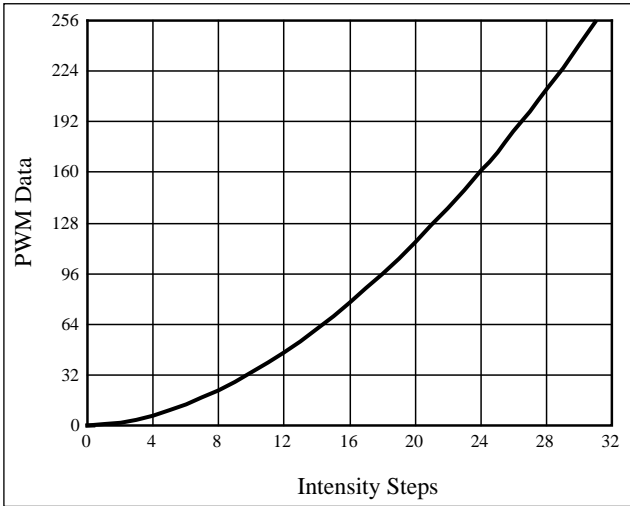

Figure 13 Gamma Correction (32 Steps)

Choosing more gamma steps provides for a more continuous looking breathing effect. This is useful for very long breathing cycles. The recommended configuration is defined by the breath cycle T. When T=1s, choose 32 gamma steps, when T=2s, choose 64 gamma steps. The user must decide the final number of gamma steps not only by the LED itself, but also based on the visual performance of the finished product.

Table 13 64 Gamma Steps with 256 PWM Steps

C(0)	C(1)	C(2)	C(3)	C(4)	C(5)	C(6)	C(7)
0	1	2	3	4	5	6	7
C(8)	C(9)	C(10)	C(11)	C(12)	C(13)	C(14)	C(15)
8	10	12	14	16	18	20	22
C(16)	C(17)	C(18)	C(19)	C(20)	C(21)	C(22)	C(23)
24	26	29	32	35	38	41	44
C(24)	C(25)	C(26)	C(27)	C(28)	C(29)	C(30)	C(31)
47	50	53	57	61	65	69	73
C(32)	C(33)	C(34)	C(35)	C(36)	C(37)	C(38)	C(39)
77	81	85	89	94	99	104	109
C(40)	C(41)	C(42)	C(43)	C(44)	C(45)	C(46)	C(47)
114	119	124	129	134	140	146	152
C(48)	C(49)	C(50)	C(51)	C(52)	C(53)	C(54)	C(55)
158	164	170	176	182	188	195	202
C(56)	C(57)	C(58)	C(59)	C(60)	C(61)	C(62)	C(63)
209	216	223	230	237	244	251	255

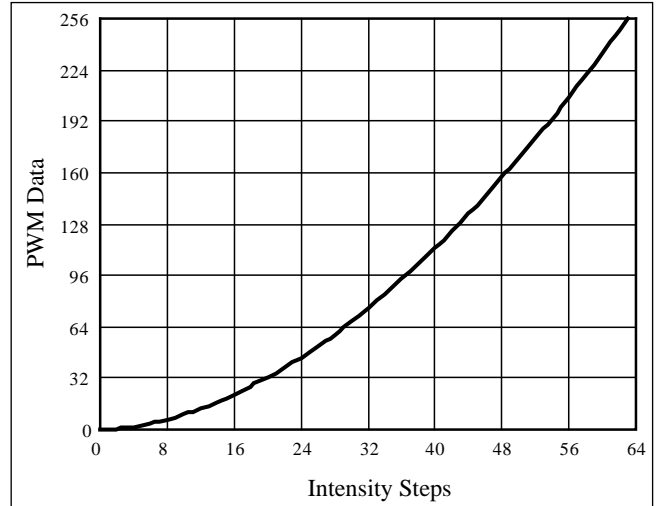

Figure 14 Gamma Correction (64 Steps)

Note: The data of 32 gamma steps is the standard value and the data of 64 gamma steps is the recommended value.

OPERATING MODE

IS31FL3729 can only operate in PWM Mode. The brightness of each LED can be modulated with 256 steps by PWM registers. For example, if the data in PWM Register is “0000 0100”, then the PWM is the fourth step.

Writing new data continuously to the registers can modulate the brightness of the LEDs to achieve a breathing effect.

OPEN/SHORT DETECT FUNCTION

IS31FL3729 has open and short detect bit for each LED.

By setting the OSDE bits of the Configuration Register (A0h) from “00” to “01” or “10”, the LED Open/short Register will start to store the open/short information and after at least 2 scanning cycles and the MCU can get the open/short information by reading the B3h~C4h, the open/short data will not get refreshed when setting the OSDE bit of the Configuration Register.

The two configurations need to set before setting the OSDE bits:

1. $0x0F \leq GCC \leq 0x40$, B0h=0x00
2. $0x01 \leq GCC \leq 0x40$, B0h=0x30

Where GCC is the Global Current Control Register (A1h) and both case 1 or two can get the correct open and short information. B0h is the Pull Down/UP Resistor Selection Register and 0x30 is to enable the SWx pull-up function.

The detect action is one-off event and each time before reading out the open/short information, the OSDE bit of the Configuration Register (A0h) need to be set from “0” to “1” (clear before set operation).

IS31FL3729

DE-GHOST FUNCTION

The “ghost” term is used to describe the behavior of an LED that should be OFF but instead glows dimly when another LED is turned ON. A ghosting effect typically can occur when multiplexing LEDs. In matrix architecture any parasitic capacitance found in the constant-current outputs or the PCB traces to the LEDs may provide sufficient current to dimly light an LED to create a ghosting effect.

To prevent this LED ghost effect, the IS31FL3729 has integrated Pull down resistors for each SW_x (x=1~9) and Pull up resistors for each CS_y (y=1~16). Select the right SW_x Pull down resistor (B0h) and CS_y Pull up resistor (B0h) which eliminates the ghost LED for a particular matrix layout configuration.

Typically, selecting the 2kΩ will be sufficient to eliminate the LED ghost phenomenon.

The SW_x Pull down resistors and CS_y Pull up resistors are active only when the CS_y/SW_x output working the OFF state and therefore no power is lost through these resistors.

SHUTDOWN MODE

Shutdown mode can be used as a means of reducing power consumption. During shutdown mode all registers retain their data.

Software Shutdown

By setting SSD bit of the Configuration Register (A0h) to “0”, the IS31FL3729 will operate in software shutdown mode. When the IS31FL3729 is in software shutdown, all current sources are switched off, so that the matrix is blanked. All registers can be operated. Typical current consume is 3μA.

Hardware Shutdown

The chip enters hardware shutdown when the SDB pin is pulled low. All analog circuits are disabled during hardware shutdown, typical the current consume is 3μA.

The chip releases hardware shutdown when the SDB pin is pulled high. During hardware shutdown state Function Register can be operated.

If V_{CC} has risk drop below 1.75V but above 0.1V during SDB pulled low, please re-initialize all Function Registers before SDB pulled high.

LAYOUT

As described in external resistor (R_{ISET}), the chip consumes lots of power. Please consider below factors when layout the PCB.

1. The V_{CC} capacitors need to close to the chip and the ground side should well connected to the GND of the chip.
2. R_{ISET} should be close to the chip and the ground side should well connect to the GND of the chip.
3. The thermal pad should connect to ground pins and the PCB should have the thermal pad too, usually this pad should have 9 or 16 via thru the PCB to other side's ground area to help radiate the heat. About the thermal pad size, please refer to the land pattern of each package.
4. The CS_y pins maximum current is 35mA (R_{ISET}=10kΩ), and the SW_x pins maximum current is larger, the width of the trace, SW_x should have wider trace than CS_y.

IS31FL3729

CLASSIFICATION REFLOW PROFILES

Profile Feature	Pb-Free Assembly
Preheat & Soak Temperature min (T _{smin}) Temperature max (T _{smax}) Time (T _{smin} to T _{smax}) (t _s)	150°C 200°C 60-120 seconds
Average ramp-up rate (T _{smax} to T _p)	3°C/second max.
Liquidous temperature (T _L) Time at liquidous (t _L)	217°C 60-150 seconds
Peak package body temperature (T _p)*	Max 260°C
Time (t _p)** within 5°C of the specified classification temperature (T _c)	Max 30 seconds
Average ramp-down rate (T _p to T _{smax})	6°C/second max.
Time 25°C to peak temperature	8 minutes max.

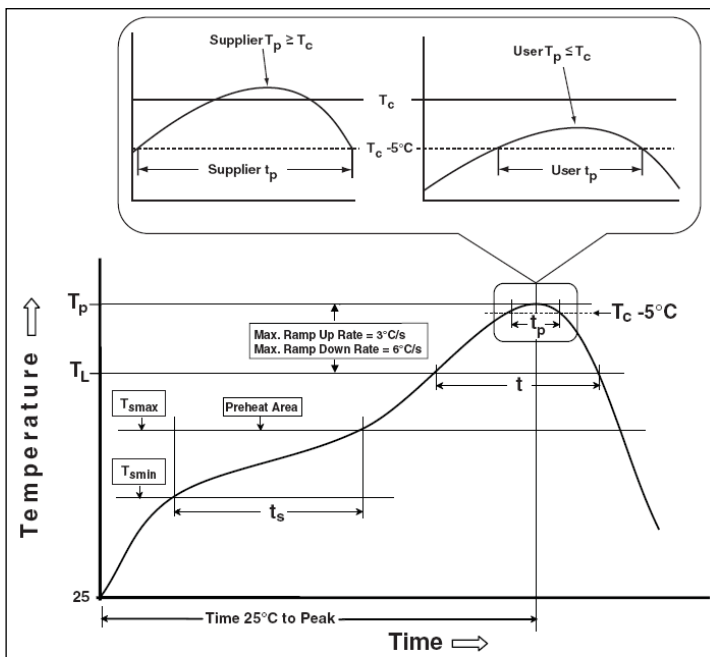
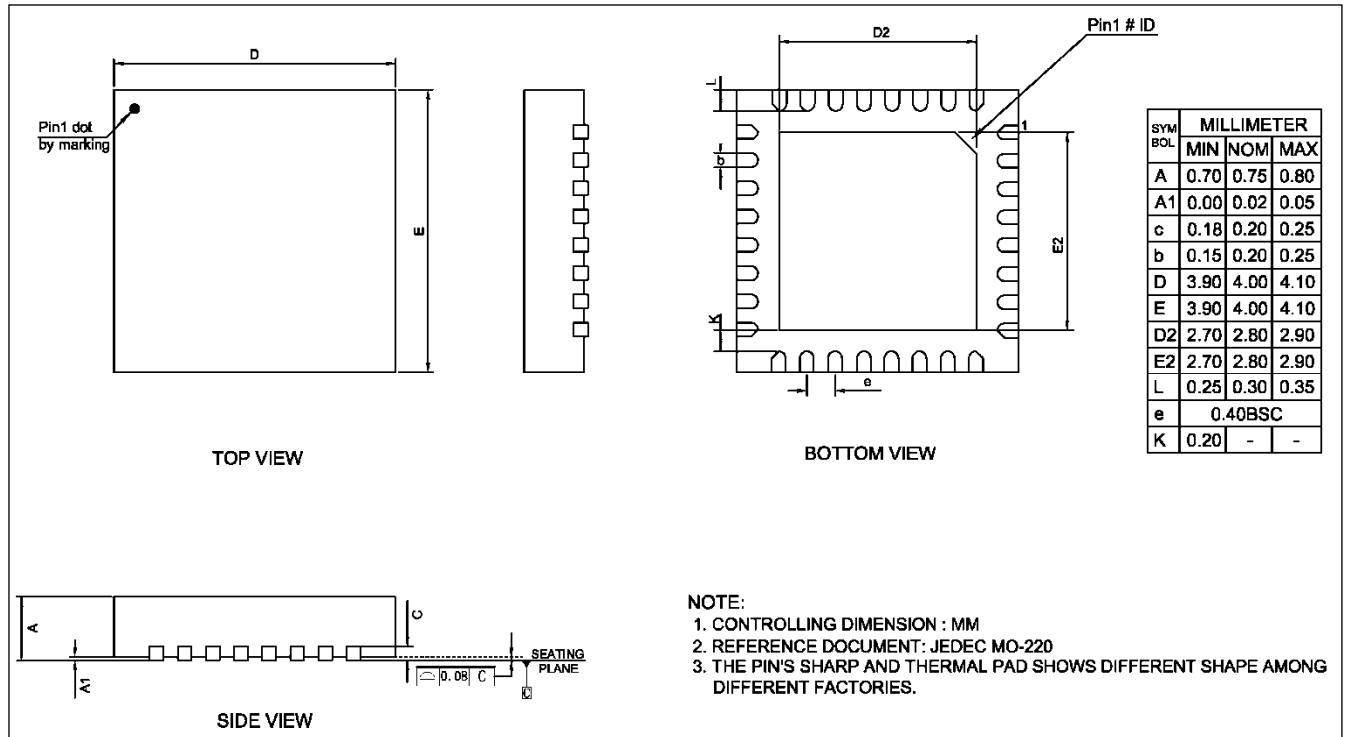

Figure 15 Classification Profile

IS31FL3729

PACKAGE INFORMATION

QFN-32



IS31FL3729

eTQFP-32

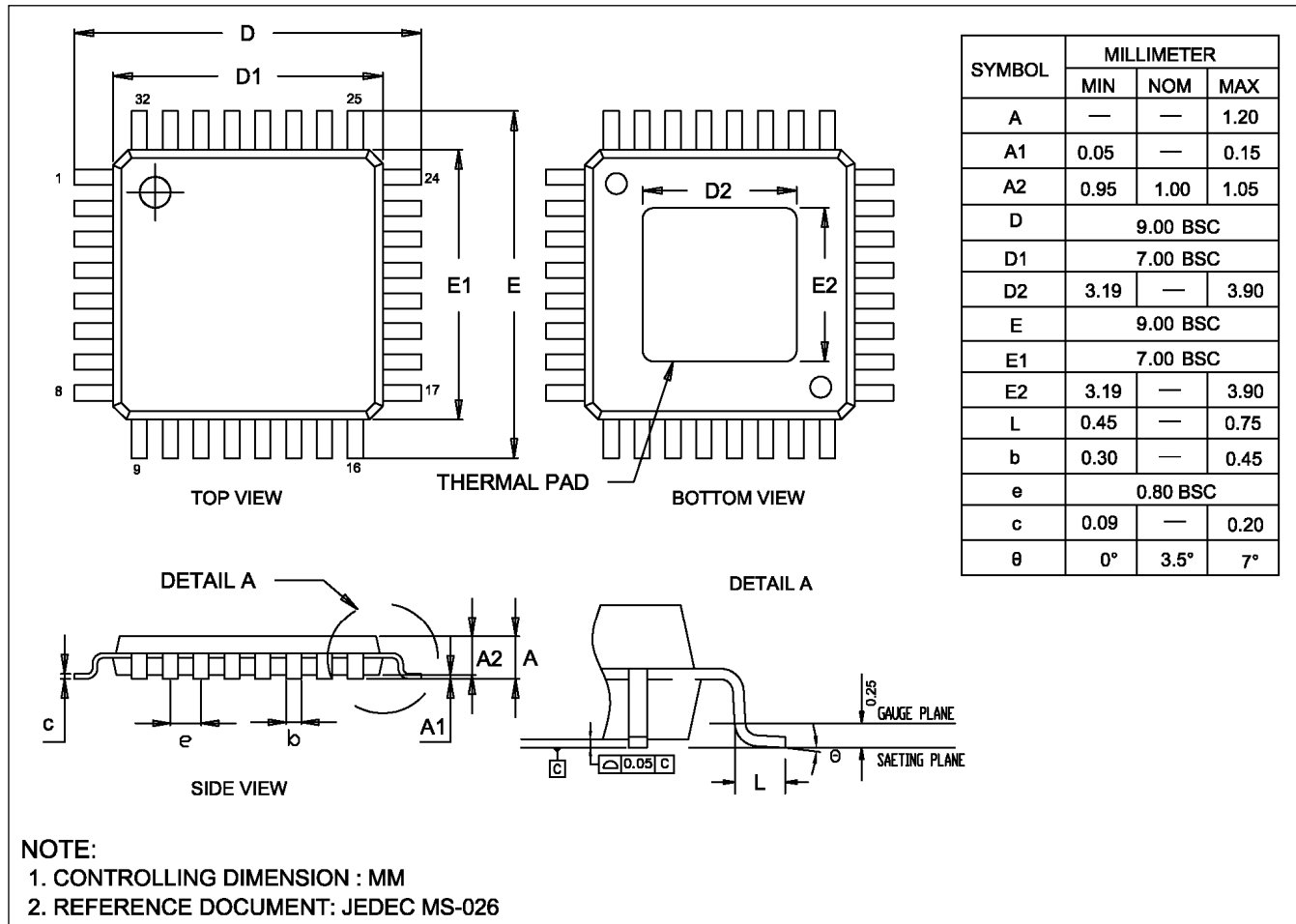

IS31FL3729

RECOMMENDED LAND PATTERN

QFN-32

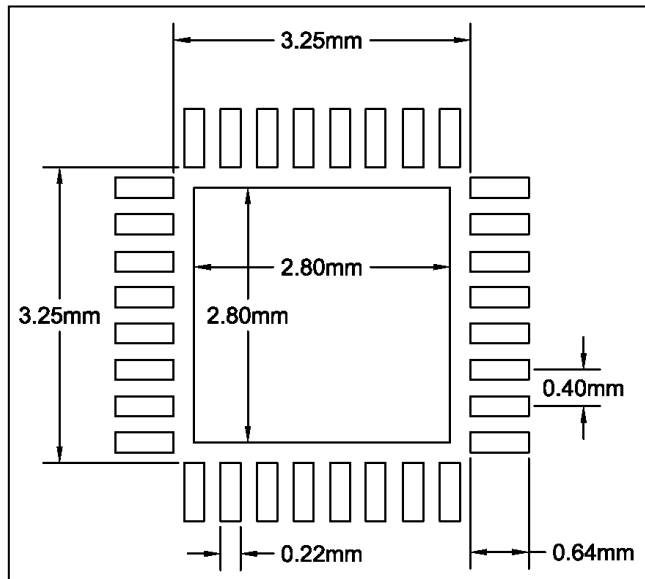

eTQFP-32

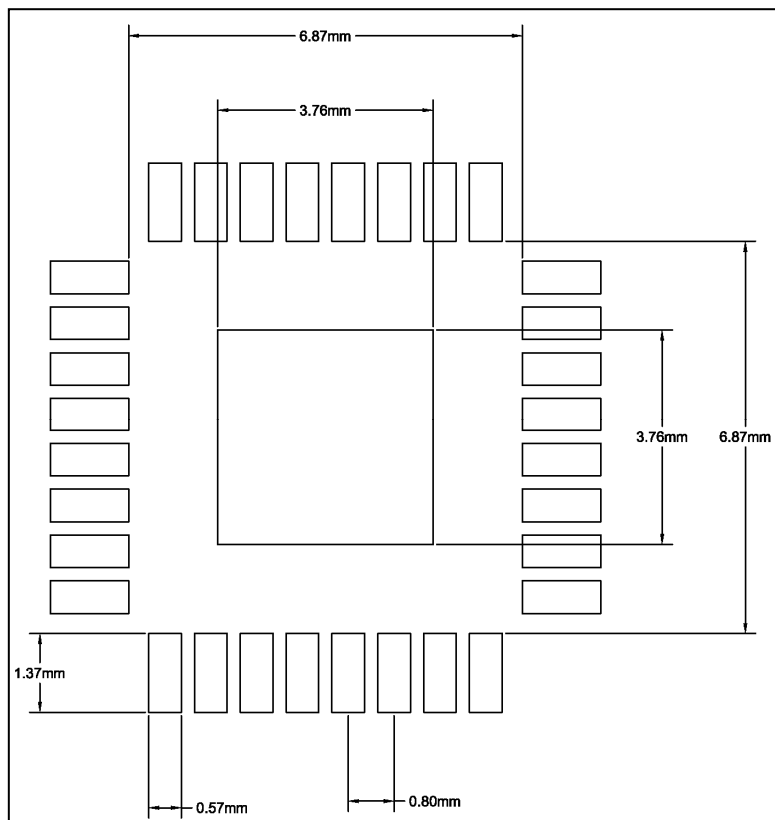

Note:

1. Land pattern complies to IPC-7351.
2. All dimensions in MM.
3. This document (including dimensions, notes & specs) is a recommendation based on typical circuit board manufacturing parameters. Since land pattern design depends on many factors unknown (eg. User's board manufacturing specs), user must determine suitability for use.

IS31FL3729

REVISION HISTORY

Revision	Detail Information	Date
0A	Preliminary release	2019.04.25
0B	Correct slave address setting in Table 1	2019.04.29
A	Add APPLICATION INFORMATION and functional block	2019.06.12
B	Add eTQFP-32 package	2019.11.29



Компания «ЭлектроПласт» предлагает заключение долгосрочных отношений при поставках импортных электронных компонентов на взаимовыгодных условиях!

Наши преимущества:

- Оперативные поставки широкого спектра электронных компонентов отечественного и импортного производства напрямую от производителей и с крупнейших мировых складов;
- Поставка более 17-ти миллионов наименований электронных компонентов;
- Поставка сложных, дефицитных, либо снятых с производства позиций;
- Оперативные сроки поставки под заказ (от 5 рабочих дней);
- Экспресс доставка в любую точку России;
- Техническая поддержка проекта, помощь в подборе аналогов, поставка прототипов;
- Система менеджмента качества сертифицирована по Международному стандарту ISO 9001;
- Лицензия ФСБ на осуществление работ с использованием сведений, составляющих государственную тайну;
- Поставка специализированных компонентов (Xilinx, Altera, Analog Devices, Intersil, Interpoint, Microsemi, Aeroflex, Peregrine, Syfer, Eurofarad, Texas Instrument, Miteq, Cobham, E2V, MA-COM, Hittite, Mini-Circuits, General Dynamics и др.);

Помимо этого, одним из направлений компании «ЭлектроПласт» является направление «Источники питания». Мы предлагаем Вам помощь Конструкторского отдела:

- Подбор оптимального решения, техническое обоснование при выборе компонента;
- Подбор аналогов;
- Консультации по применению компонента;
- Поставка образцов и прототипов;
- Техническая поддержка проекта;
- Защита от снятия компонента с производства.



Как с нами связаться

Телефон: 8 (812) 309 58 32 (многоканальный)

Факс: 8 (812) 320-02-42

Электронная почта: org@eplast1.ru

Адрес: 198099, г. Санкт-Петербург, ул. Калинина, дом 2, корпус 4, литера А.