

THIS DOCUMENT IS THE PROPERTY OF APDM COMPONENTS AND SHALL NOT BE COPIED, REPRODUCED, DISCLOSED OR USED AS THE BASIS FOR MANUFACTURING OR SALE WITHOUT PERMISSION OF A DULY AUTHORIZED REPRESENTATIVE OF APDM COMPONENTS INC.

ATMG53*V*
 OPERATION FORCE: _____
 3=160gf
 4=260gf
 PACKAGE STYLE:
 T/R=TAPE AND REEL
 LEAD FREE

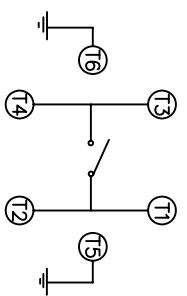
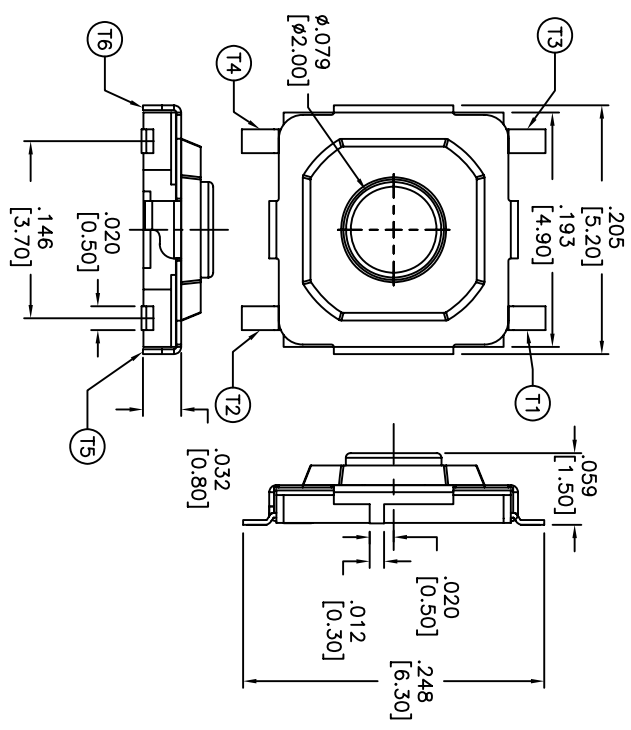
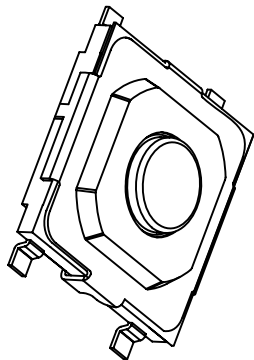
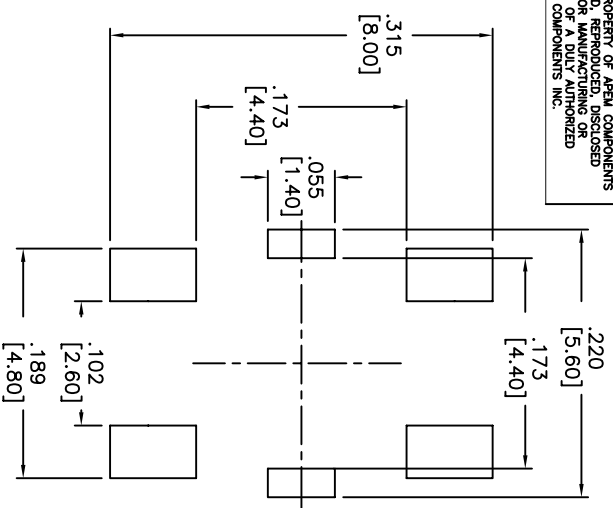

CIRCUIT DIAGRAM

DATE	SYM	REVISION RECORD	DWN.	CK.
11/05	B	ECO# 495	CD	

DESCRIPTION: MINIATURE MACHANICAL CONTACT SWITCH WITH SURFACE MOUNT TERMINALS AND GROUNDING TERMINALS.
 SPECIFICATIONS:
 STROKE: .010 ^{+0.004} _{-0.008} [0.25 ^{+0.10} _{-0.20}]
 OPERATION TEMPERATURE RANGE: -25°C TO +70°C
 STORAGE TEMPERATURE RANGE: -30°C TO +80°C
 VIBRATION TEST: PASSES METHOD 201A MIL-STD-202F.
 SHOCK TEST: 50G PER METHOD 213B MIL-STD202F.
 ELECTRICAL LIFE: 1,000,000 CYCLES MIN FOR 160gf.
 200,000 CYCLES MIN FOR 260gf.
 RATING: 50mA, 12VDC.
 CONTACT RESISTANCE: 100mΩ MAX.
 INSULATION RESISTANCE: 100MΩ MIN. AT 500VDC.
 DIELECTRIC STRENGTH: 250VAC/1 MINUTE.
 CONTACT ARRANGEMENT: 1POLE 1 THROW.
 MATERIALS:
 COVER: NICKEL SILVER.
 BASE: HIGH-TEMP. THERMOPLASTIC.
 COLOR: BLACK.
 STEM: BRASS WITH NICKEL PLATING
 CONTACT DISC: STAINLESS STEEL.
 TERMINAL: BRASS WITH SILVER CLADDING.
 TAPE: TEFLON
 SOLDERING:
 HAND SOLDERING: 30 WATT IRON AT 350°C FOR 5 SEC.
 VAPOR & REFLOW: 255°C FOR 5 SEC. MAX.
 NON-WASHABLE
 LEAD FREE PROCESS COMPATIBLE
 ROHS COMPLIANT

APDM APDM COMPONENTS, INC. 63 Nork Rd. Torrington, CT 06805 Phone: 860-772-5554 Fax: 860-772-5554		DPN: CJD BR: PJD
DESIGNS: OPTICAL DIMENSION	TOLERANCES (UNLESS AS NOTED) .XX = ±0.005 .XXX = ±0.004 [0.20] .XXXX = ±0.0008 [0.02] ANGLE = 30.5°	SHEET 1 OF 1 SIZE B SCALE 10:1 THIRD ANGLE PROJECTION
TITLE MECHANICAL CONTACT SWITCH		DATE 08/15/05
DO NOT SCALE DRAWING		DRAWING NO. ATMG53*V*

THIS DOCUMENT IS THE PROPERTY OF APDM COMPONENTS AND SHALL NOT BE COPIED, REPRODUCED, DISCLOSED OR USED AS THE BASIS FOR MANUFACTURING OR SALE WITHOUT PERMISSION OF A DULY AUTHORIZED REPRESENTATIVE OF APDM COMPONENTS INC.

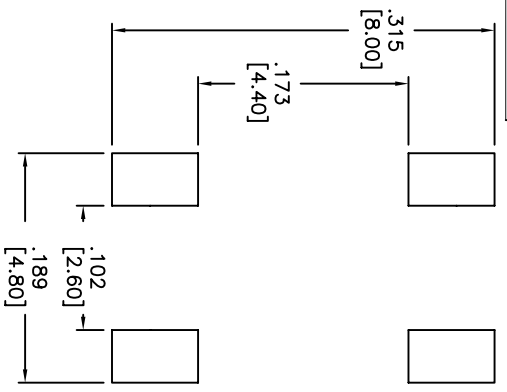

P.C.B. LAYOUT

OPERATION FORCE: ATM53*V*
 2=100gf
 3=160gf
 4=260gf
 PACKAGE STYLE: T/R=TAPE AND REEL
 LEAD FREE

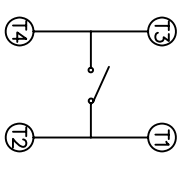
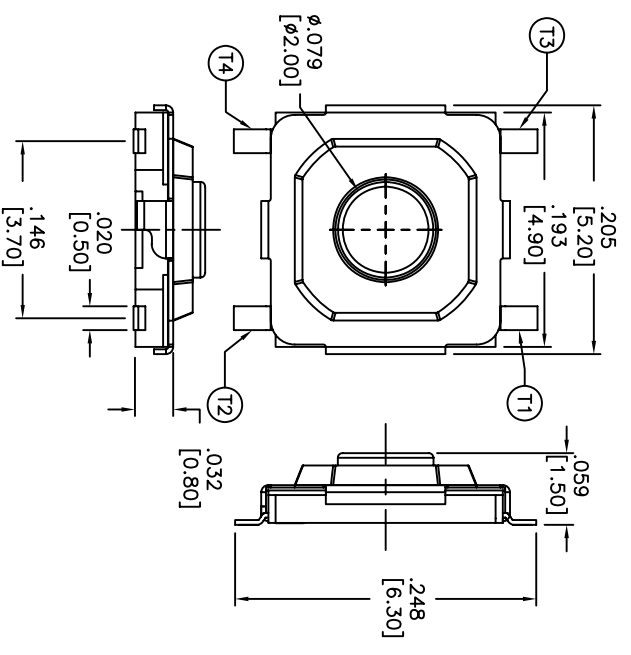
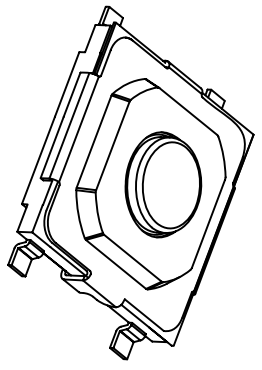

CIRCUIT DIAGRAM

DATE	SYM	REVISION RECORD	DWN.	CK.

DESCRIPTION: MINIATURE MECHANICAL CONTACT SWITCH
 SURFACE MOUNT TERMINALS.
 SPECIFICATIONS:
 STROKE: .010 \pm .004 \pm .006 \pm .001
 OPERATION TEMPERATURE RANGE: -25°C TO +70°C
 STORAGE TEMPERATURE RANGE: -30°C TO +80°C
 VIBRATION TEST: PASSES METHOD 201A MIL-STD-202F.
 SHOCK TEST: 50G PER METHOD 213B MIL-STD202F.
 ELECTRICAL LIFE: 1,000,000 CYCLES MIN FOR 100gf, 16
 200,000 CYCLES MIN FOR 260gf.
 RATING: 50mA, 12VDC.
 CONTACT RESISTANCE: 100mΩ MAX.
 INSULATION RESISTANCE: 100MΩ MIN. AT 500VDC.
 DIELECTRIC STRENGTH: 250VAC/1 MINUTE.
 CONTACT ARRANGEMENT: 1POLE 1 THROW.
 MATERIALS:
 COVER: NICKEL SILVER.
 BASE: HIGH-TEMP. THERMOPLASTIC.
 COLOR: BLACK.
 STEM: BRASS WITH NICKEL PLATING
 CONTACT DISC: STAINLESS STEEL WITH SILVER PLATING.
 TERMINAL: BRASS WITH SILVER CLADDING.
 TAPE: TEFLON
 SOLDERING:
 HAND SOLDERING: 30 WATT IRON AT 350°C FOR 5 SEC
 VAPOR & REFLOW: 255°C FOR 5 SEC. MAX.
 NON-WASHABLE
 LEAD FREE PROCESS COMPATIBLE
 ROHS COMPLIANT

APDM APDM COMPONENTS INC. 63 NACK RD. HENRIEVILLE, NY 13355 TEL: 518-752-5554 FAX: 518-752-5554		DPN: CJD BR: PJD
9A. INSECT. DIMENSIONS: OPTICAL TOLERANCES (UNLESS AS NOTED) .XX=±.02(0.05) .XXX=±.008(0.20) .XXXX=±.0008(0.02) ANGLE = 30.5°	TITLE MECHANICAL CONTACT SWITCH	SHEET 1 OF 1 SIZE B SCALE 10:1 THIRD ANGLE PROJECTION
DO NOT SCALE DATE 4/26/06 DRAWING NO. ATM53*V*	REV A	REV A

THIS DOCUMENT IS THE PROPERTY OF APEM COMPONENTS AND SHALL NOT BE COPIED, REPRODUCED, DISCLOSED OR SALE WITHOUT PERMISSION OF A DULY AUTHORIZED REPRESENTATIVE OF APEM COMPONENTS INC.

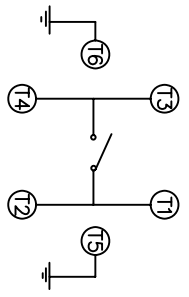

CIRCUIT DIAGRAM

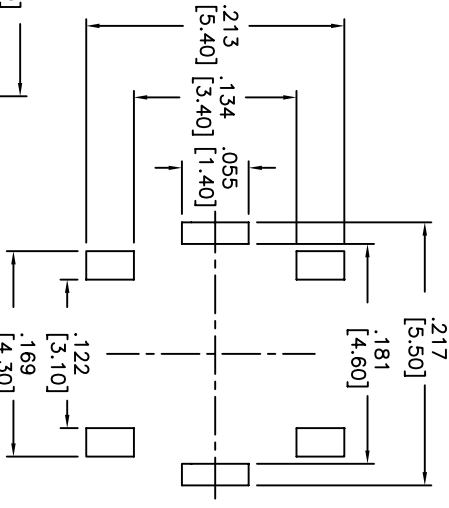

PCB LAYOUT

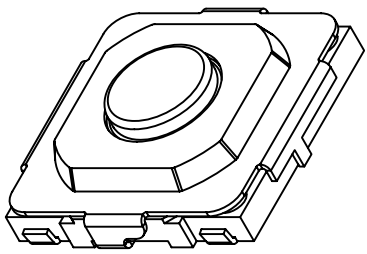
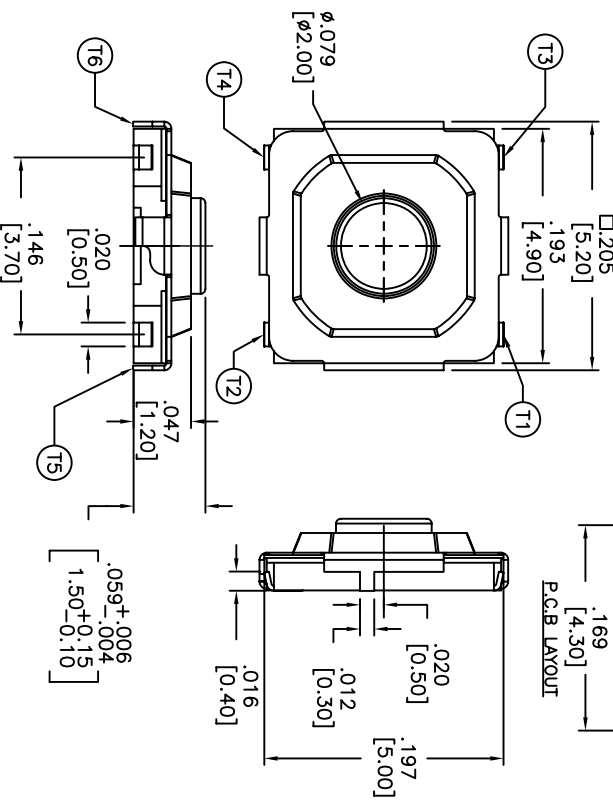

OPERATION FORCE: ATUG53**V* PACKAGE STYLE: T/R=TAPE AND REEL
 3=160gf
 4=260gf
 LEAD FREE

DESCRIPTION: MINIATURE MECHANICAL CONTACT SWITCH WITH "S" TYPE SMT AND GROUNDING TERMINALS.

SPECIFICATIONS:

OPERATION TEMPERATURE RANGE: -25°C TO +70°C
 STORAGE TEMPERATURE RANGE: -30°C TO +80°C
 VIBRATION TEST: PASSES METHOD 201A
 MIL-STD-202F.
 SHOCK TEST: 50G PER METHOD 213B MIL-STD202F.
 ELECTRICAL LIFE: 1,000,000 CYCLES MIN FOR 160gf.
 200,000 CYCLES MIN FOR 260gf.

RATING: 50mA, 12VDC.
 CONTACT RESISTANCE: 100mΩ MAX.
 INSULATION RESISTANCE: 100MΩ MIN. AT 500VDC.
 DIELECTRIC STRENGTH: 250VAC/1 MINUTE.
 STROKE: 0.25 ±0.10mm
 CONTACT ARRANGEMENT: 1POLE 1 THROW.

MATERIALS:
 COVER: NICKEL SILVER.
 BASE: HIGH-TEMP. THERMOPLASTIC.
 COLOR: BLACK.
 STEM: BRASS WITH NICKEL PLATING
 CONTACT DISC: STAINLESS STEEL.
 TERMINAL: BRASS WITH SILVER CLADDING.
 TAPE: TEFLON

SOLDERING:
 HAND SOLDERING: 30 WATT IRON AT 350°C FOR 5 SEC.
 IR REFLOW: 225°C MAX.
 LEAD FREE PROCESS COMPATIBLE
 ROHS COMPLIANT

DATE	SYM	REVISION RECORD	DWN.	CK.

Q.A. INSPECT: 		DESIGNER'S INITIAL: DIMENSION		DRN. CJD	
TOLERANCES (UNLESS OTHERWISE SPECIFIED) .XX = ±0.02 [0.05] .XXX = ±0.008 [0.20] .XXXX = ±0.0008 [0.02] ANGLE = 30.5°		APM 63 Neck Rd. Haverhill, MA 01830 Tel: 978-372-5554 Fax: 978-372-5554		BR. BR. OK. PJD	
TITLE MECHANICAL CONTACT SWITCH		SHEET 1 OF 1		SCALE 10:1	
DATE 8/11/05		DRAWING NO. ATUG53*V*		REV A	

THIS DOCUMENT IS THE PROPERTY OF APM COMPONENTS AND SHALL NOT BE COPIED, REPRODUCED, DISCLOSED OR SALE WITHOUT PERMISSION OF A DULY AUTHORIZED REPRESENTATIVE OF APM COMPONENTS INC.

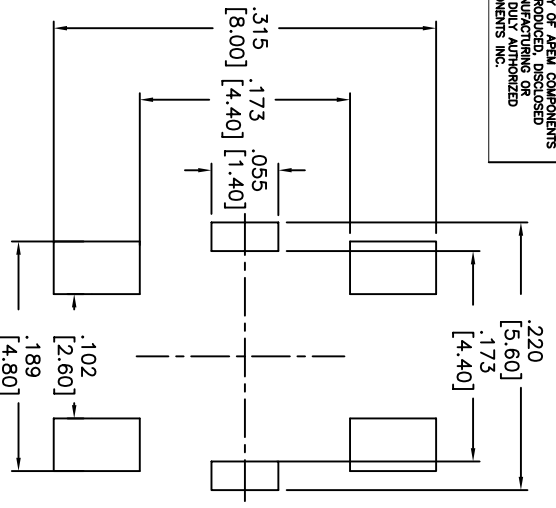

P.C.B. LAYOUT
UNLESS OTHERWISE SPECIFIED
ALL P.C. TOLERANCES ARE ±.002 [0.05]

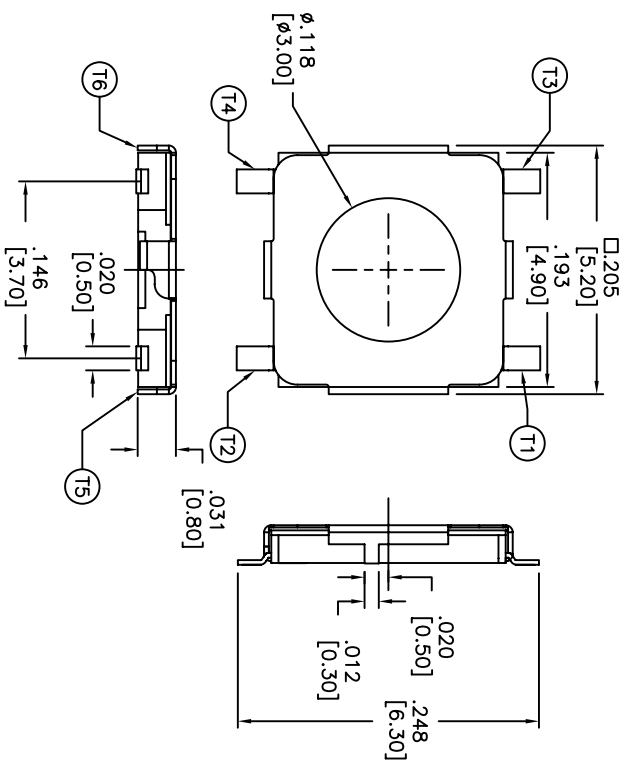

OPERATION FORCE: ATMG52*V*
2=100gf
3=160gf
4=260gf

PACKAGE STYLE:
T/R=TAPE AND REEL
LEAD FREE

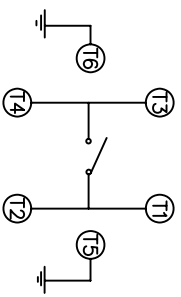
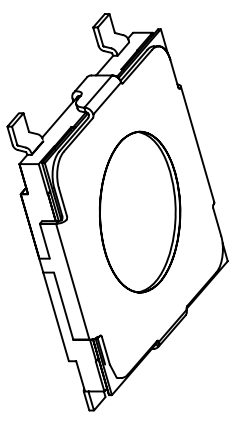

CIRCUIT DIAGRAM

DESCRIPTION: MINIATURE MECHANICAL CONTACT SWITCH WITH SMT, AND GROUNDING TERMINALS.

SPECIFICATIONS:

OPERATION TEMPERATURE RANGE: -25°C TO +70°C

STORAGE TEMPERATURE RANGE: -30°C TO +80°C

VIBRATION TEST: PASSES METHOD 2014 MIL-STD-202F.

SHOCK TEST: 50G PER METHOD 213B MIL-STD202F.

ELECTRICAL LIFE: 1,000,000 CYCLES MIN FOR 100gf AND 160gf. 200,000 CYCLES MIN FOR 260gf.

RATING: 50mA, 12VDC.

CONTACT RESISTANCE: 100mΩ MAX.

INSULATION RESISTANCE: 100MΩ MIN. AT 500VDC.

DIELECTRIC STRENGTH: 250VAC/1 MINUTE.

CONTACT ARRANGEMENT: 1POLE 1 THROW.

MATERIALS:

COVER: NICKEL SILVER.

BASE: HIGH-TEMP. THERMOPLASTIC.

COLOR, BLACK.

STEM: BRASS WITH NICKEL PLATING

CONTACT DISC: STAINLESS STEEL WITH SILVER CLADDING.

TERMINAL: BRASS WITH SILVER PLATING.

TAPE: TEFLON

SOLDERING:

HAND SOLDERING: 30 WATT IRON AT 350°C FOR 5 SEC.

IR REFLOW: 260°C MAX

LEAD FREE PROCESS COMPATIBLE

ROHS COMPLIANT

DATE	SYM	REVISION RECORD	DWN.	CK.

<p>Q.A. INSPECT: DESIGNER: CRITICAL DIMENSION</p>		<p>APM COMPONENTS INC. 63 NACK RD. 01835 Haverhill, MA 01835 Tel: 978-372-5554 Fax: 978-372-5554</p>		<p>DRN. CJD BR. BR. OR. PJD</p>	
<p>TOLERANCES (UNLESS OTHERWISE SPECIFIED) XXX=±.0008[0.20] XX=±.0018[0.45] X=±.0025[0.63] ANGLE = 40.5°</p>		<p>SHEET 1 OF 1</p>	<p>SIZE B</p>	<p>SCALE 10:1</p>	<p>THIRD ANGLE PROJECTION</p>
<p>DATE: 8/15/05</p>		<p>DRAWING NO. ATMG52*V*</p>		<p>REV. A</p>	

THIS DOCUMENT IS THE PROPERTY OF APEN COMPONENTS AND SHALL NOT BE COPIED, REPRODUCED, DISCLOSED OR USED AS THE BASIS FOR MANUFACTURING OR SALE WITHOUT PERMISSION OF A DULY AUTHORIZED REPRESENTATIVE OF APEN COMPONENTS INC.

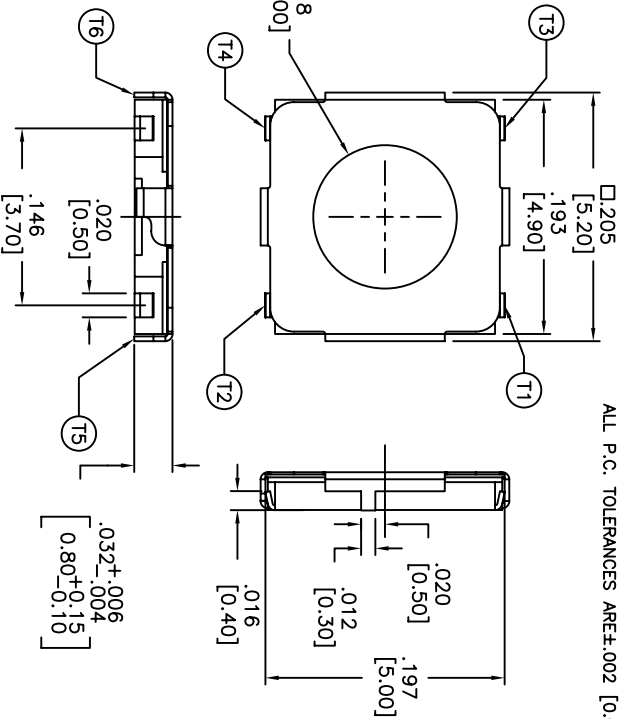
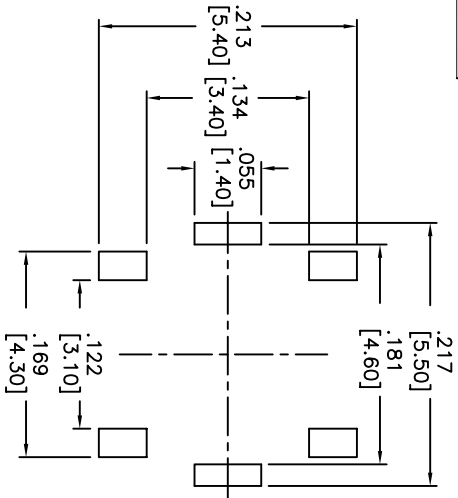

P.C.B LAYOUT
UNLESS OTHERWISE SPECIFIED
ALL P.C. TOLERANCES ARE ±.002 [0.05]

OPERATION FORCE: ATUG52**V*
2=100gf
3=160gf
4=260gf

PACKAGE STYLE:
T/R=TAPE AND REEL
LEAD FREE

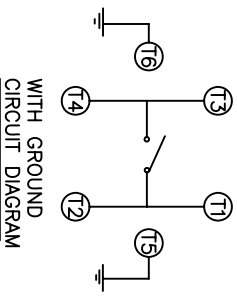
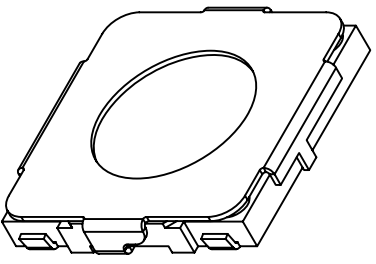

DESCRIPTION: MINIATURE MECHANICAL CONTACT SWITCH WITH J TYPE SMT AND GROUNDING TERMINALS.

SPECIFICATIONS:
OPERATION TEMPERATURE RANGE: -25°C TO +70°C
STORAGE TEMPERATURE RANGE: -30°C TO +80°C
VIBRATION TEST: PASSES METHOD 201A MIL-STD-202F.
SHOCK TEST: 50G PER METHOD 213B MIL-STD202F.
ELECTRICAL LIFE: 1,000,000 CYCLES MIN FOR 100gf 160gf.
200,000 CYCLES MIN FOR 260gf.
RATING: 50mA, 12VDC.
CONTACT RESISTANCE: 100mΩ MAX.
INSULATION RESISTANCE: 100MΩ MIN. AT 500VDC.
DIELECTRIC STRENGTH: 250VAC/1 MINUTE.
STROKE: 0.25 ±0.08mm
CONTACT ARRANGEMENT: 1POLE 1 THROW.

MATERIALS:
COVER: NICKEL SILVER.
BASE: HIGH-TEMP. THERMOPLASTIC.
COLOR: BLACK.
STEM: BRASS WITH NICKEL PLATING
CONTACT DISC: STAINLESS STEEL WITH SILVER CLADDING.
TERMINAL: BRASS WITH SILVER PLATING.
TAPE: TEFLON

SOLDERING:
HAND SOLDERING: 30 WATT IRON AT 350°C FOR 5 SEC.
IR REFLOW: 260°C MAX.
LEAD FREE PROCESS COMPATIBLE
ROHS COMPLIANT

DATE	SYM	REVISION RECORD	DWN.	CK.

Q.A. INSPECT:		63 Nark. Rd. 01835 Haverhill, MA 01835 APEN COMPONENTS, INC. Phone: 978-372-5554		DRN. CJD
DESIGNATES CRITICAL DIMENSION	APEN	DR. BR.	OR. PJD	THIRD ANGLE PROJECTION
TOLERANCES (UNLESS OTHERWISE SPECIFIED)	INCH	SHEET	SIZE	SCALE
.XX = ±.02 [0.05]	1	OF 1	B	10:1
.XXX = ±.008 [0.20]	MECHANICAL CONTACT SWITCH			
.XXXX = ±.0008 [0.02]	DATE: 8/11/06			
ANGLE = 30.5°	DRAWING NO. ATUG52**V*			
DO NOT SCALE DRAWING	REV. A			



Компания «ЭлектроПласт» предлагает заключение долгосрочных отношений при поставках импортных электронных компонентов на взаимовыгодных условиях!

Наши преимущества:

- Оперативные поставки широкого спектра электронных компонентов отечественного и импортного производства напрямую от производителей и с крупнейших мировых складов;
- Поставка более 17-ти миллионов наименований электронных компонентов;
- Поставка сложных, дефицитных, либо снятых с производства позиций;
- Оперативные сроки поставки под заказ (от 5 рабочих дней);
- Экспресс доставка в любую точку России;
- Техническая поддержка проекта, помощь в подборе аналогов, поставка прототипов;
- Система менеджмента качества сертифицирована по Международному стандарту ISO 9001;
- Лицензия ФСБ на осуществление работ с использованием сведений, составляющих государственную тайну;
- Поставка специализированных компонентов (Xilinx, Altera, Analog Devices, Intersil, Interpoint, Microsemi, Aeroflex, Peregrine, Syfer, Eurofarad, Texas Instrument, Miteq, Cobham, E2V, MA-COM, Hittite, Mini-Circuits, General Dynamics и др.);

Помимо этого, одним из направлений компании «ЭлектроПласт» является направление «Источники питания». Мы предлагаем Вам помощь Конструкторского отдела:

- Подбор оптимального решения, техническое обоснование при выборе компонента;
- Подбор аналогов;
- Консультации по применению компонента;
- Поставка образцов и прототипов;
- Техническая поддержка проекта;
- Защита от снятия компонента с производства.



Как с нами связаться

Телефон: 8 (812) 309 58 32 (многоканальный)

Факс: 8 (812) 320-02-42

Электронная почта: org@eplast1.ru

Адрес: 198099, г. Санкт-Петербург, ул. Калинина, дом 2, корпус 4, литера А.