

Features

- Very Low DC Power Consumption: 100 μ W
- Low Insertion Loss: 0.5 dB
- High Isolation: 25 dB up to 2 GHz
- Very High Intercept Point: 45 dBm IP₃
- Nanosecond Switching Speed
- Lead-Free SOIC-8 Package
- 100% Matte Tin Plating over Copper
- Halogen-Free "Green" Mold Compound
- 260°C Reflow Compatible
- RoHS* Compliant Version of the SW-239

Description

The MASWSS0157 is a GaAs MMIC SPDT switch in a lead-free SOIC 8-lead surface mount plastic package. This device is ideally suited for use where low power consumption is required.

Typical applications include transmit/receive switching, switch matrices and switched filter banks in systems such as radio and cellular equipment, PCM, GPS, fiber optic modules, and other battery powered radio equipment.

The MASWSS0157 is fabricated using a monolithic GaAs MMIC using a mature 1 micron process. The process features full chip passivation for increased performance and reliability.

Ordering Information ¹

Part Number	Package
MASWSS0157	Bulk Packaging
MASWSS0157TR	1000 piece reel
MASWSS0157TR-3000	3000 piece reel
MASWSS0157SMB	Sample Test Board

1. Reference Application Note M513 for reel size information.

Functional Schematic

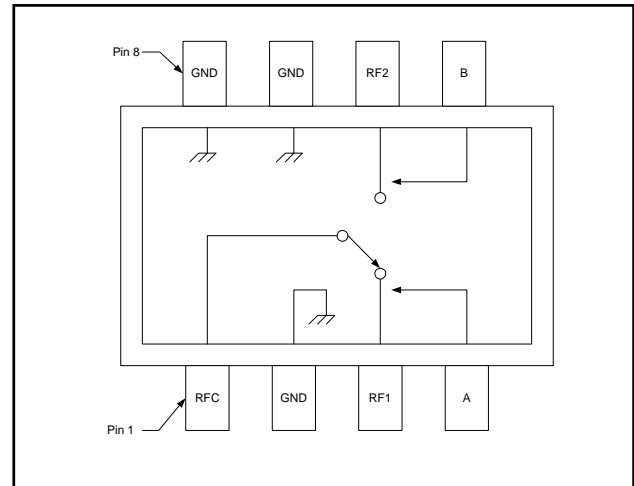

Pin Configuration

Pin No.	Function
1	RF Common
2	Ground
3	RF Port 1
4	Control A
5	Control B
6	RF Port 2
7	Ground
8	Ground

* Restrictions on Hazardous Substances, European Union Directive 2002/95/EC.

Electrical Specifications: $T_A = 25^\circ\text{C}$, $V_c = 0\text{ V} / -5\text{ V}$, $Z_0 = 50\ \Omega$ ²

Parameter	Test Conditions	Units	Min.	Typ.	Max.
Insertion Loss	DC - 0.1 GHz	dB	—	0.4	—
	DC - 0.5 GHz		—	0.4	—
	DC - 1.0 GHz		—	0.5	0.8
	DC - 2.0 GHz		—	0.6	—
Isolation	DC - 0.1 GHz	dB	—	56	—
	DC - 0.5 GHz		—	43	—
	DC - 1.0 GHz		30	33	—
	DC - 2.0 GHz		—	24	—
VSWR	DC - 2.0 GHz	Ratio	—	1.4:1	—
Trise, Tfall	10% to 90% RF, 90% to 10% RF	ns	—	2	—
Ton, Toff	50% Control to 90% RF, 50% Control to 10% RF	ns	—	4	—
Transients	In-Band	mV	—	15	—
1 dB Compression Point	Input Power, 0.05 GHz	dBm	—	21	—
	Input Power, 0.5 - 2.0 GHz		—	27	—
2nd Order Intercept	Measured Relative to Input Power (for two-tone input power up to +6 dBm) 0.05 GHz	dBm	—	55	—
	0.5 - 2.0 GHz		—	68	—
3rd Order Intercept	Measured Relative to Input Power (for two-tone input power up to +6 dBm) 0.05 GHz	dBm	—	40	—
	0.5 - 2.0 GHz		—	45	—
Control Current	$\frac{1}{2}V_c\frac{1}{2} = 5\text{ V}$	μA	—	20	25

2. For positive voltage control, external DC blocking capacitors are required on all RF ports as well as the Ground ports which should be pulled up to the positive voltage control level. (Refer to Application Note M521 - "Positive Voltage Control of GaAs MMIC Control Devices").

Absolute Maximum Ratings ^{3,4}

Parameter	Absolute Maximum
Input Power 0.05 GHz 0.5 - 2.0 GHz	+27 dBm +34 dBm
Control Voltage	$-8.5\text{ V} \leq V_c \leq +5\text{ V}$
Operating Temperature	-40°C to $+85^\circ\text{C}$
Storage Temperature	-65°C to $+150^\circ\text{C}$

3. Exceeding any one or combination of these limits may cause permanent damage to this device.
4. M/A-COM does not recommend sustained operation near these survivability limits.

Truth Table ⁵

Control Inputs		Condition of Switch RF Common to each RF Port	
A	B	RF1	RF2
1	0	On	Off
0	1	Off	On

5. 0 = 0 V to -0.2 V, 1 = -5 V to -8 V

2

ADVANCED: Data Sheets contain information regarding a product M/A-COM Technology Solutions is considering for development. Performance is based on target specifications, simulated results, and/or prototype measurements. Commitment to develop is not guaranteed.

PRELIMINARY: Data Sheets contain information regarding a product M/A-COM Technology Solutions has under development. Performance is based on engineering tests. Specifications are typical. Mechanical outline has been fixed. Engineering samples and/or test data may be available. Commitment to produce in volume is not guaranteed.

• **North America** Tel: 800.366.2266 • **Europe** Tel: +353.21.244.6400
• **India** Tel: +91.80.43537383 • **China** Tel: +86.21.2407.1588
Visit www.macomtech.com for additional data sheets and product information.

M/A-COM Technology Solutions Inc. and its affiliates reserve the right to make changes to the product(s) or information contained herein without notice.

Typical Performance Curves

Insertion Loss

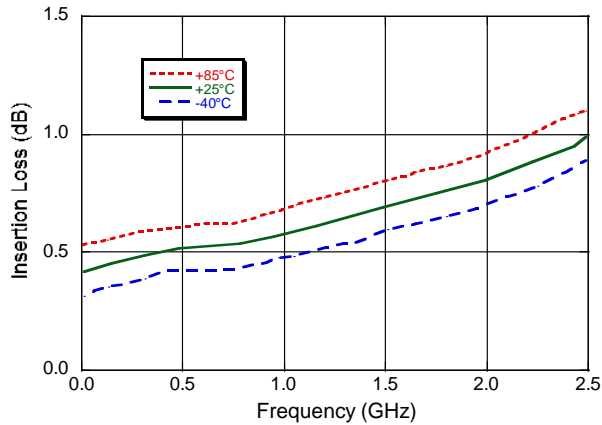

Isolation

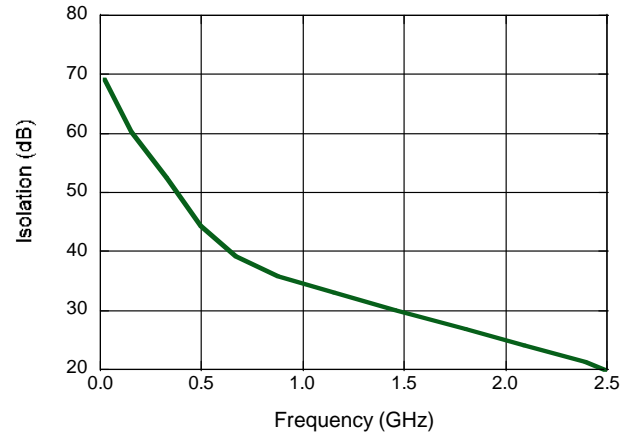

VSWR

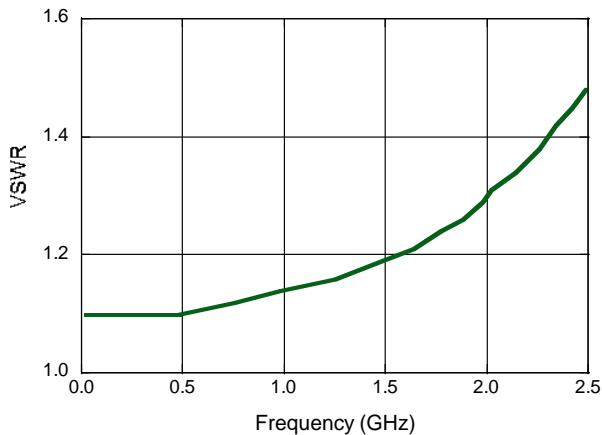

Electrical Schematic

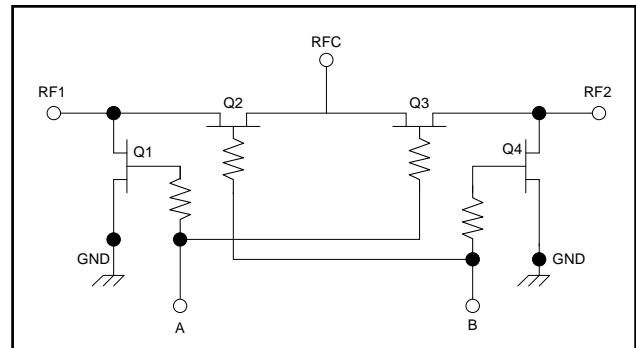

Lead-Free SOIC-8[†]

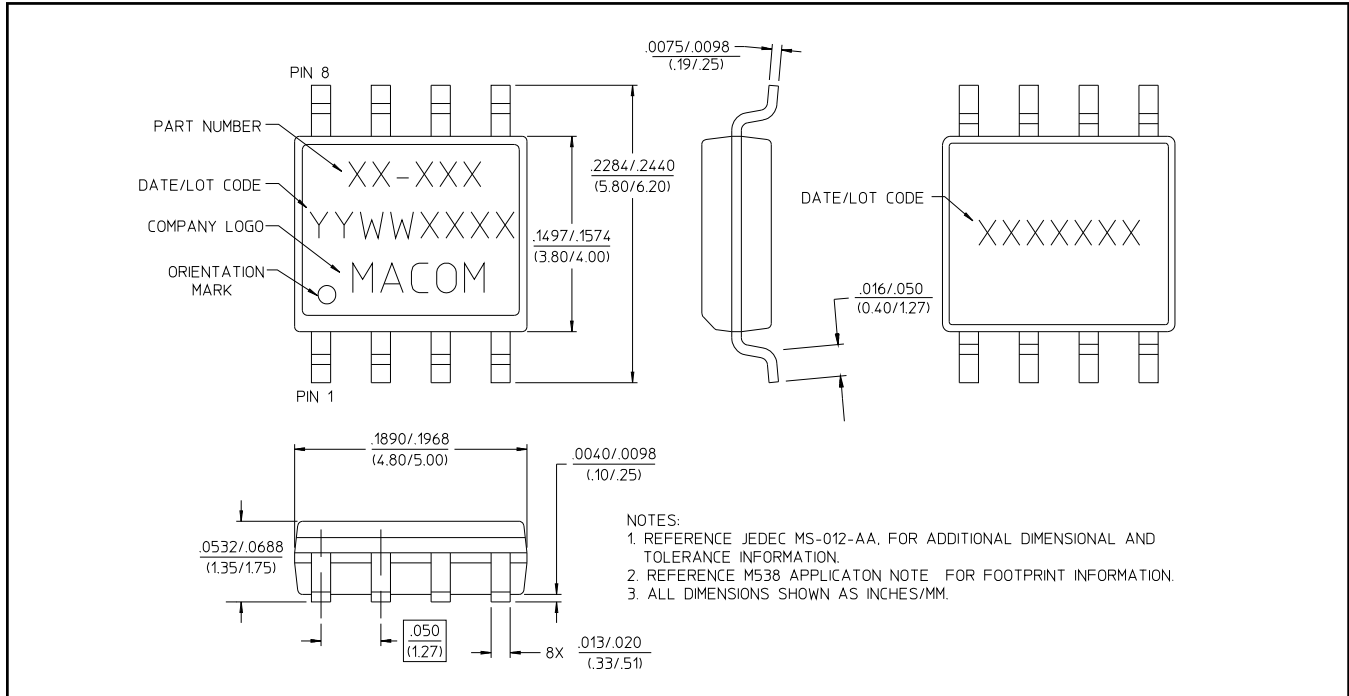

[†] Reference Application Note M538 for lead-free solder reflow recommendations.

Handling Procedures

Please observe the following precautions to avoid damage:

Static Sensitivity

Gallium Arsenide Integrated Circuits are sensitive to electrostatic discharge (ESD) and can be damaged by static electricity. Proper ESD control techniques should be used when handling these devices.



Компания «ЭлектроПласт» предлагает заключение долгосрочных отношений при поставках импортных электронных компонентов на взаимовыгодных условиях!

Наши преимущества:

- Оперативные поставки широкого спектра электронных компонентов отечественного и импортного производства напрямую от производителей и с крупнейших мировых складов;
- Поставка более 17-ти миллионов наименований электронных компонентов;
- Поставка сложных, дефицитных, либо снятых с производства позиций;
- Оперативные сроки поставки под заказ (от 5 рабочих дней);
- Экспресс доставка в любую точку России;
- Техническая поддержка проекта, помощь в подборе аналогов, поставка прототипов;
- Система менеджмента качества сертифицирована по Международному стандарту ISO 9001;
- Лицензия ФСБ на осуществление работ с использованием сведений, составляющих государственную тайну;
- Поставка специализированных компонентов (Xilinx, Altera, Analog Devices, Intersil, Interpoint, Microsemi, Aeroflex, Peregrine, Syfer, Eurofarad, Texas Instrument, Miteq, Cobham, E2V, MA-COM, Hittite, Mini-Circuits, General Dynamics и др.);

Помимо этого, одним из направлений компании «ЭлектроПласт» является направление «Источники питания». Мы предлагаем Вам помощь Конструкторского отдела:

- Подбор оптимального решения, техническое обоснование при выборе компонента;
- Подбор аналогов;
- Консультации по применению компонента;
- Поставка образцов и прототипов;
- Техническая поддержка проекта;
- Защита от снятия компонента с производства.



Как с нами связаться

Телефон: 8 (812) 309 58 32 (многоканальный)

Факс: 8 (812) 320-02-42

Электронная почта: org@eplast1.ru

Адрес: 198099, г. Санкт-Петербург, ул. Калинина, дом 2, корпус 4, литера А.