



The Infinite Bandwidth Company™

MICRF005

115kbps, 800MHz - 1GHz UHF Receiver

Final Information

General Description

The MICRF005 QwikRadio™ UHF receiver is a single-chip OOK (on-off keyed) receiver IC for remote wireless applications. This device is a true single-chip, "antenna-in, data-out" device. All RF and IF tuning is accomplished automatically within the IC which eliminates manual tuning production costs and results in a highly reliable, extremely low-cost solution for high-volume wireless applications.

The MICRF005 provides two additional key features: (1) A transmit standby mode, and (2) a shutdown mode which may be used for duty-cycle operation. These features make the MICRF005 ideal for low power applications in both one-way and bi-directional wireless links.

All IF and post-detection (demodulator) data filtering is provided on the MICRF005, no external filters are required. Nominal filter bandwidth is fixed a 300kHz allowing a data throughput at rates up to 115kbps.

Features

- 800MHz to 1000MHz frequency range
- Data rates up to 115kbps
- No filters or inductors required
- Low 10mA operating supply current at 868MHz
- Shutdown mode for >10:1 duty-cycle operation
- Very low RF antenna re-radiation
- CMOS logic interface for standard ICs
- Extremely low external part count
- Transmit standby mode for bi-directional link control

Applications

- Wireless game controllers
- Security systems
- Medium-rate data modems

Ordering Information

Part Number	Junction Temp. Range	Package
MICRF005BM	-40°C to +85°C	14-Lead SOIC

Typical Application

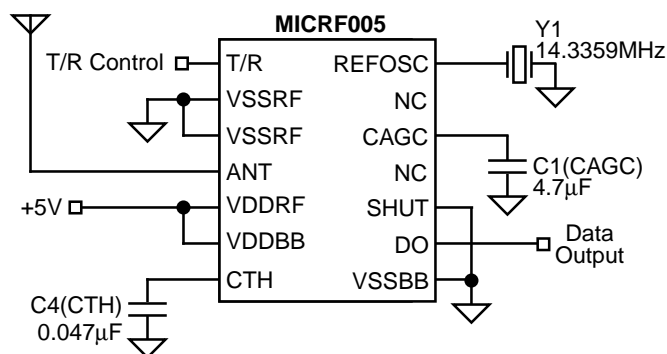

915MHz, 115kbps OOK ISM Band Receiver

QwikRadio is a trademark of Micrel Semiconductor.

The QwikRadio ICs were developed under a partnership agreement with AIT of Orlando, Florida.

Pin Configuration

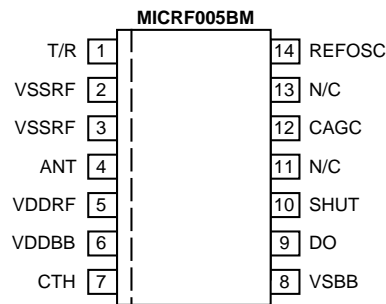

Standard 14-Pin SOP (M) Package

Pin Description

Pin Number	Pin Name	Pin Function
1	T/R	Transmit/Receive control switch. Pull low to enable receiver function.
2, 3	VSSRF	This pin is the ground return for the RF section of the IC. The bypass capacitor connected from the VDDRF to VSSRF should have the shortest possible lead length. For best performance, connect VSSRF to VSSBB at the power supply only (i.e. keep VSSBB currents from flowing through VSSRF return paths).
4	ANT	This is the receive RF input, internally ac-coupled. Connect this pin to the receive antenna. For applications located in high ambient noise environments, a fixed value band-pass network may be connected between the ANT pin and VSSRF to provide additional receive selectivity and input overload protection.
5	VDDRF	This pin is the positive supply input for the RF section of the IC. VDDBB and VDDRF should be connected together directly at the IC pins.
6	VDDBB	This pin is the positive supply input for the baseband section of the IC. VDDBB and VDDRF should be connected together at the IC pins.
7	CTH	This capacitor extracts the (DC) average value from the demodulated waveform which becomes the reference for the internal data slicing comparator. Treat as a low-pass RC filter with source impedance of nominally 30k Ω . A standard $\pm 20\%$ X7R ceramic capacitor is generally sufficient.
8	VSSBB	This is the ground return for the baseband section of the IC. The bypass and output capacitors connected to VSSBB should have the shortest possible leads lengths. For best performance, connect VSSRF to VSSBB at the power supply only (i.e., keep VSSBB currents from flowing through VSSRF return path).
9	DO	CMOS-level compatible data output signal.
10	SHUT	Shutdown-mode logic-level control input. Pull low to enable the receiver. This pin is internally pulled-up to VDDRF.
11	NC	No connection
12	CAGC	Integrating capacitor for on-chip AGC (Automatic Gain Control). The Decay/Attack time-constant (TC) ratio is nominally set as 10:1. Use of 0.47 μ F or greater is strongly recommended for best range performance. Use low-leakage type capacitors for duty-cycle operation (Dip Tantalum, Ceramic, Polyester).
13	NC	No connection
14	REFOSC	This is the timing reference for on-chip tuning and alignment. Connect crystal between this pin and VSSBB, or drive the input with an AC coupled 0.5V _{pp} input clock.

Absolute Maximum Ratings (Note 1)

Supply Voltage (V_{DDRF}, V_{DDBB})	+7V
Reference Oscillator Input Voltage (V_{REFOSC})	V_{DDBB}
Input/Output Voltage ($V_{I/O}$)	$V_{SS}-0.3$ to $V_{DD}+0.3$
Junction Temperature (T_J)	+150°C
Storage Temperature Range (T_S)	-65°C to +150°C
Lead Temperature (soldering, 10 sec.)	+260°C
ESD Rating, Note 3	

Operating Ratings (Note 2)

Supply Voltage (V_{DDRF}, V_{DDBB})	+4.75V to +5.5V
Ambient Temperature (T_A)	-40°C to +85°C

Electrical Characteristics

$V_{DDRF} = V_{DDBB} = V_{DD}$ where $4.75V \leq V_{DD} \leq 5.5V$, $V_{SS} = 0V$; $V_{T/R} = V_{SHUT} = 0V$; $C_{AGC} = 0.47\mu F$, $C_{TH} = 4.7nF$, 115kbps data-rate (Manchester encoded); $f_{REFOSC} = 14.3359MHz$ ($f_{RF} = 915MHz$); $T_A = 25^\circ C$, **bold** values indicate $-40^\circ C \leq T_A \leq +85^\circ C$; current flow into device pins is positive; unless noted.

Symbol	Parameter	Condition	Min	Typ	Max	Units
I_{OP}	Operating Current	continuous operation		10	13.5 18.5	mA
		10:1 duty cycle		1		mA
I_{STBY}	Standby Current	$V_{T/R} = V_{SHUT} = V_{DD}$		11		μA

RF Section, IF Section

	Receiver Sensitivity	Notes 4, 6	-81	-84		dBm
f_{IF}	IF Center Frequency	Note 7		2.496		MHz
f_{BW}	IF 3dB Bandwidth	Notes 7		1.2		MHz
	Maximum Receive Data Rate		115			kb/s
f_{ANT}	RF Input Range		800		1000	MHz
	Receive Modulation Duty-Cycle		20		80	%
	Maximum Receiver Input	$R_S = 50\Omega$		-10		dBm
	Spurious Reverse Isolation	ANT pin, $R_{SC} = 50\Omega$, Note 5		30		μV_{rms}
	AGC Attack to Decay Ratio	$t_{ATTACK} \div t_{DECAY}$, Note 9		0.1		
	AGC Leakage Current	$T_A = +85^\circ C$, $V_{SHUT} = V_{DD}$ or $V_{T/R} = V_{DD}$, Note 9		± 200		nA

Reference Oscillator

	Synthesizer Stabilization Time	to 1% of final value		1.2		ms
Z_{REFOSC}	Reference Oscillator Input Impedance			300		k Ω
	OSC Input Voltage		300			mVp-p

Demodulator

Z_{CTH}	CTH Source Impedance	Note 8, 9		26		k Ω
ΔZ_{CTH}	CTH Source Impedance Variation	Note 9		± 15		%
	Demodulator Filter Bandwidth	Notes 7		300		kHz

Symbol	Parameter	Condition	Min	Typ	Max	Units
Digital/Control Section						
$I_{IN(pu)}$	V_{SHUT} Pull-Up Current	$V_{SHUT} = V_{SS}$		8.5		μA
$I_{IN(pd)}$	$V_{T/R}$ Pull-Down Current	$V_{T/R} = V_{DD}$		12		μA
$V_{IN(high)}$	$V_{T/R}, V_{SHUT}$, Input-High Voltage		$V_{DD}-0.5$			V
$V_{IN(low)}$	$V_{T/R}, V_{SHUT}$, Input-Low Voltage				0.5	V
I_{OUT}	Output Current	DO, push-pull		90		μA
$V_{OUT(high)}$	Output-High Voltage	DO, $I_{OUT} = -5\mu A$	$0.9V_{DD}$			V
$V_{OUT(low)}$	Output-Low Voltage	DO, $I_{OUT} = 5\mu A$			$0.1V_{DD}$	V
t_R, t_F	Output Rise and Fall Times	DO, $C_{LOAD} = 10pF$		tbd		μs

Note 1. Exceeding the absolute maximum rating may damage the device.

Note 2. The device is not guaranteed to function outside its operating rating.

Note 3. Devices are ESD sensitive. Handling precautions recommended.

Note 4: Sensitivity is defined as the average signal level measured at the input necessary to achieve 10^{-2} BER (bit error rate). The input signal is defined as a return-to-zero (RZ) waveform with 50% average duty cycle (Manchester encoded data). The RF input is assumed to be matched into 50Ω .

Note 5: Spurious reverse isolation represents the spurious components which appear on the RF input pin (ANT) measured into 50Ω with an input RF matching network. Parameter guaranteed by device characterization, not production tested.

Note 6: Sensitivity, a commonly specified receiver parameter, provides an indication of the receiver's input referred noise, generally input thermal noise. However, it is possible for a more sensitive receiver to exhibit range performance no better than that of a less sensitive receiver if the background noise is appreciably higher than the thermal noise. Background noise refers to other interfering signals, such as FM radio stations, pagers, etc.

A better indicator of achievable receiver range performance is usually given by its selectivity, often stated as intermediate frequency (IF) or radio frequency (RF) bandwidth, depending on receiver topology. Selectivity is a measure of the rejection by the receiver of "ether" noise. More selective receivers will almost invariably provide better range. Only when the receiver selectivity is so high that most of the noise on the receiver input is actually thermal will the receiver demonstrate sensitivity-limited performance.

Note 7: Parameter scales linearly with reference oscillator frequency f_T . For any reference oscillator frequency other than 14.3359MHz, compute new parameter value as the ratio:

$$\frac{f_{REFOSC}MHz}{14.3359} \times (\text{parameter value at } 14.3359MHz)$$

Note 8: Parameter scales inversely with reference oscillator frequency f_T . For any reference oscillator frequency other than 14.3359MHz, compute new parameter value as the ratio:

$$\frac{14.3359}{f_{REFOSC}MHz} \times (\text{parameter value at } 14.3359MHz)$$

Note 9: Parameter guaranteed by design (not tested).

Typical Characteristics

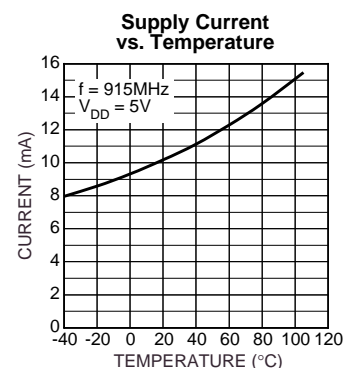
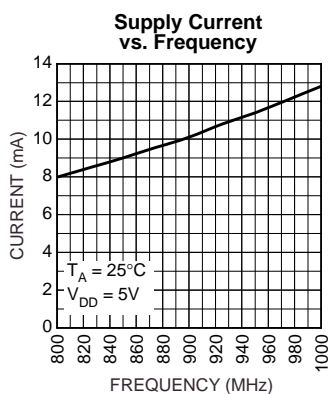

Functional Diagram

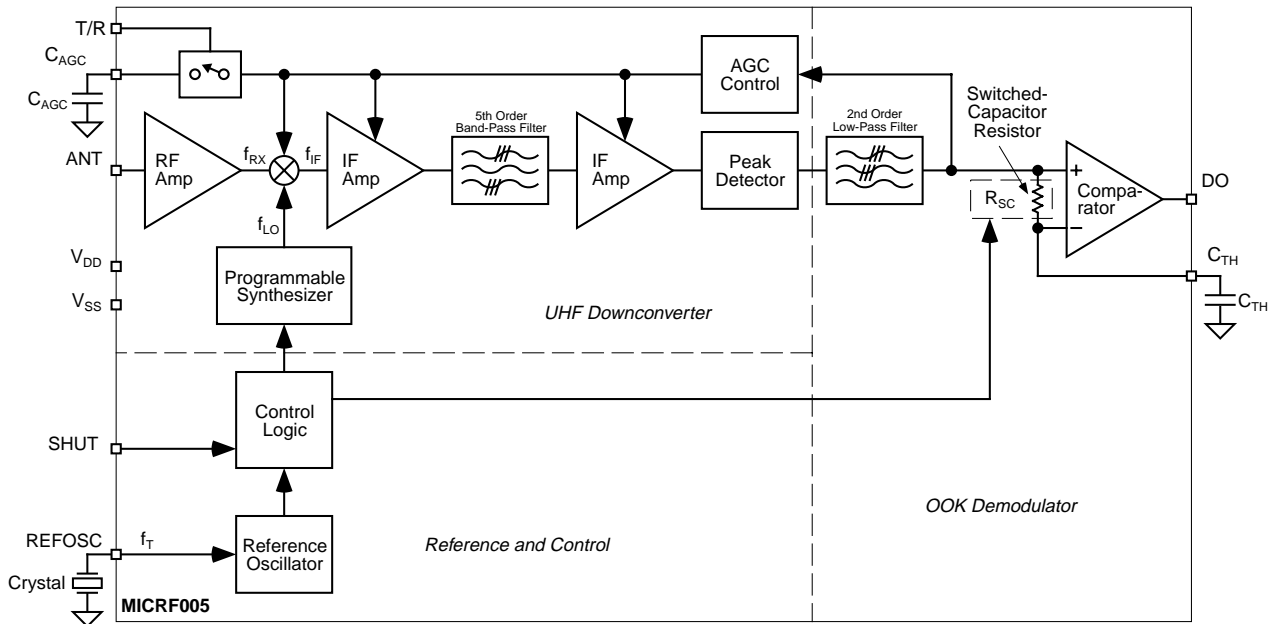

MICRF005 Block Diagram

Functional Description

Refer to "MICRF005 Block Diagram". Identified in the block diagram are the three sections of the IC: UHF Downconverter, OOK Demodulator and Reference and Control. Also shown in the figure are two capacitors (C_{TH} , C_{AGC}) and one timing component (CR), usually a crystal. With the exception of a supply decoupling capacitor, these are the only external components needed by the MICRF005 to construct a complete UHF receiver. Two control inputs are shown in the block diagram: T/R and SHUT. Through these logic inputs, the user can control the operation of the IC. These inputs are CMOS compatible, and are pulled-up on the IC.

IF Bandpass Filter

Rolloff response of the IF Filter is 7th order, while the demodulator data filter exhibits a 2nd order response.

Slicing Level

Extraction of the dc value of the demodulated signal for purposes of logic-level data slicing is accomplished using the external threshold capacitor C_{TH} and the on-chip switched-capacitor "resistor" R_{SC} , shown in the block diagram. The effective resistance of R_{SC} is 30k Ω .

Slicing level time constant values vary somewhat with decoder type, data pattern, and data rate, but typical values range from 5ms to 50ms. Optimization of the value of C_{TH} is required to maximize range.

Squelch

During quiet periods (no signal) the data output (DO pin) transitions randomly with noise, presenting problems for some decoders. A simple solution is to introduce a small offset, or squelch voltage, on the C_{TH} pin so that noise does not trigger the internal comparator. Usually 20mV to 30mV is sufficient, and may be introduced by connecting a several-

M Ω resistor from the C_{TH} pin to either V_{SS} or V_{DD} , depending on the desired offset polarity. Since the MICRF005 has receiver AGC, noise at the internal comparator input is always the same, set by the AGC. The squelch offset requirement does not change as the local noise strength changes from installation to installation. Introducing squelch will reduce range modestly. Only introduce an amount of offset sufficient to quiet the output.

Automatic Gain Control

The signal path has AGC (automatic gain control) to increase input dynamic range. An external capacitor, C_{AGC} , must be connected to the C_{AGC} pin of the device. The ratio of decay-to-attack time-constant is fixed at 10:1 (that is, the attack time constant is 1/10th of the decay time constant). However, the attack time constant is set externally by choosing a value for C_{AGC} .

By adding resistance from the C_{AGC} pin to V_{DDBB} or V_{SSBB} in parallel with the AGC capacitor, the ratio of decay-to-attack time constant may be varied, although the value of such adjustments must be studied on a per-application basis. Generally the design value of 10:1 is adequate for the vast majority of applications.

To maximize system range, it is important to keep the AGC control voltage ripple low, preferably under 10mVpp once the control voltage has attained its quiescent value. For this reason capacitor values of at least 0.47 μ F are recommended.

The AGC control voltage is carefully managed on-chip to allow duty-cycle operation of the MICRF005 in excess of 10:1. When the device is placed into shutdown mode (SHUT pin pulled high), the AGC capacitor floats, to retain the voltage. When operation is resumed, only the voltage droop on the capacitor due to leakage must be replenished, therefore a relatively low-leakage capacitor is recommended for

duty-cycled operation. The actual tolerable leakage will be application dependent. Clearly, leakage performance is less critical when the device off-time is low (milliseconds) and more critical when the off-time is high (seconds).

To further enhance duty-cycled operation of the IC, the AGC push and pull currents are increased for a fixed time immediately after the device is taken out of shutdown mode (turned-on). This compensates for AGC capacitor voltage droop while the IC is in shutdown mode, and therefore extends maximum achievable duty ratios. Push-pull currents are increased by 45 times their nominal values. The fixed time period is based on the reference oscillator frequency f_T , [ms] for $f_T = 14.3359\text{MHz}$, and varies inversely as f_T varies.

Transmit / Standby Function

The transmit/receive function is controlled by the logic state of T/R. T/R is internally tied to V_{SS} . When T/R is open circuit or in the low state, the MICRF005 functions in its normal receive operating mode. The T/R pin may be pulled high to Vdd, this will place the receiver in a “stand-by” operating mode. This mode is intended for use during transmit cycles in transceiver applications where the receiver is co-located with a transmitter. In this “transmit” mode, the receiver oscillator remains active but the AGC function is disabled and the CAGC pin is high impedance to hold the AGC capacitor voltage. This function enables the MICRF005 to immediately resume receive operation after a transmit cycle.

Shutdown Function

The shutdown function is controlled by a logic state applied to the SHUT pin. When V_{SHUT} is high, the device goes into low-power standby mode, consuming less than $1\mu\text{A}$. This pin is pulled high internally. It must be externally pulled low to enable the receiver.

Reference Oscillator

All timing and tuning operations on the MICRF005 are derived from the internal Colpitts reference oscillator. Timing and tuning is controlled through the REFOSC pin in one of two ways:

1. Connect a crystal
2. Drive this pin with an external timing signal

The second approach is attractive for lowering system cost further if an accurate reference signal exists elsewhere in the system, for example, a reference clock from a crystal-controlled microprocessor. An externally applied signal should be ac-coupled and resistively-attenuated, or otherwise limited, to approximately 0.5Vpp . The specific reference frequency required is related to the system transmit frequency.

I/O Pin Interface Circuitry

Interface circuitry for the various I/O pins of the MICRF005 are diagrammed in Figures 1 through 6. The ESD protection diodes at all input and output pins are not shown. Integrated into an actual design application with the best results possible.

CTH Pin

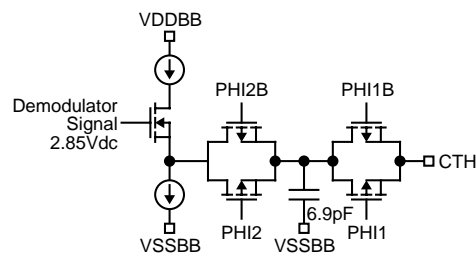

Figure 2. C_{TH} Pin

Figure 2 illustrates the CTH-pin interface circuit. The CTH pin is driven from a P-channel MOSFET source-follower with approximately $10\mu\text{A}$ of bias. Transmission gates TG1 and TG2 isolate the 6.9pF capacitor. Internal control signals PHI1/PHI2 are related in a manner such that the impedance across the transmission gates looks like a “resistance” of approximately $100\text{k}\Omega$. The dc potential at the CTH pin is approximately 1.6V .

CAGC Pin

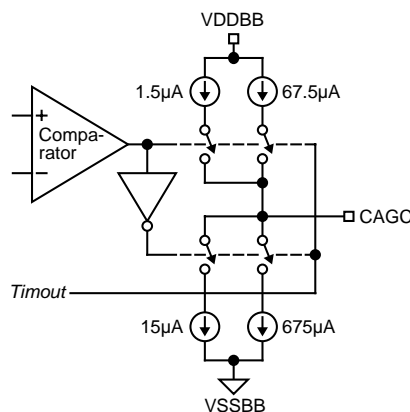

Figure 3. C_{AGC} Pin

Figure 3 illustrates the CAGC pin interface circuit. The AGC control voltage is developed as an integrated current into a capacitor C_{AGC} . The attack current is nominally $15\mu\text{A}$, while the decay current is a $1/10$ th scaling of this, nominally $1.5\mu\text{A}$, making the attack/decay timeconstant ratio a fixed $10:1$. Signal gain of the RF/IF strip inside the IC diminishes as the voltage at CAGC decreases. Modification of the attack/decay ratio is possible by adding resistance from the CAGC pin to either V_{DDBB} or V_{SSBB} , as desired.

Both the push and pull current sources are disabled during shutdown, which maintains the voltage across C_{AGC} , and improves recovery time in duty-cycled applications. To further improve duty-cycle recovery, both push and pull currents are increased by 45 times for approximately 10ms after release of the SHUT pin. This allows rapid recovery of any voltage droop on C_{AGC} while in shutdown.

DO Pin

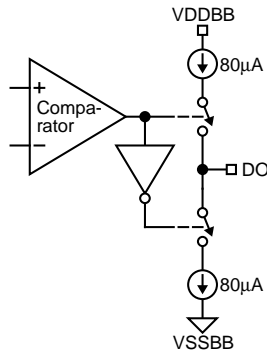

Figure 4. DO Pin

The output stage for DO (digital output) is shown in Figure 4. The output is a 90µA push and 90µA pull switched-current stage. This output stage is capable of driving CMOS loads. An external buffer-driver is recommended for driving high-capacitance loads.

REFOSC Pin

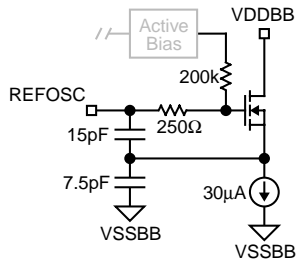

Figure 5. REFOSC Pin

The REFOSC input circuit is shown in Figure 5. Input impedance is high (300kΩ). This is a Colpitts oscillator with internal capacitors. The nominal dc bias voltage on this pin is 1.4V.

SHUT Pin

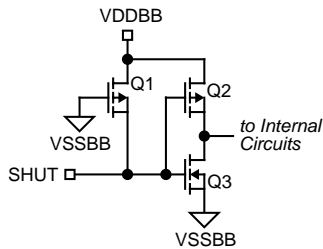

Figure 6. SHUT Pin

Control input circuitry is shown in Figures 6. The standard input is a logic inverter constructed with minimum geometry MOSFETs (Q2, Q3). P-channel MOSFET Q1 is a large channel length device which functions essentially as a “weak”

pullup to V_{DDBB} . Typical pullup current is 8.5µA, leading to an impedance to the V_{DDBB} supply of typically 1MΩ.

T/R Pin

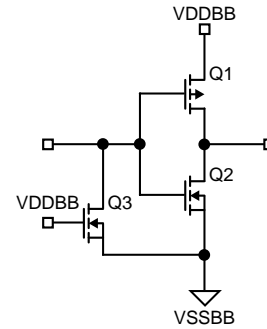

Figure 7. T/R Pin

The transmit/receive function is controlled by the logic state of T/R. T/R is internally tied to V_{SS} . When T/R is open circuit or in the low state, the MICRF005 functions in its normal receive operating mode. The T/R pin may be pulled high to Vdd, this will place the receiver in a “stand-by” operating mode. This mode is intended for use during transmit cycles in transceiver applications where the receiver is co-located with a transmitter. In this “transmit” mode, the receiver oscillator remains active but the AGC function is disabled and the C_{AGC} pin is tri-stated to hold the AGC capacitor voltage. This function enables the MICRF005 to quickly resume receive operation after a transmit cycle.

Application Information

Bypass and Output Capacitors

The bypass and output capacitors connected to V_{SSBB} should have the shortest possible lead lengths. For best performance, connect V_{SSRF} to V_{SSBB} at the power supply only (that is, keep V_{SSBB} currents from flowing through the V_{SSRF} return path). V_{DDRF} and V_{DDBB} should be connected directly together at the IC pins. A 10Ω resistor in series with the supply line plus three decoupling capacitors is recommended. The suggested capacitor values are 1nF, 10nF and 100nF.

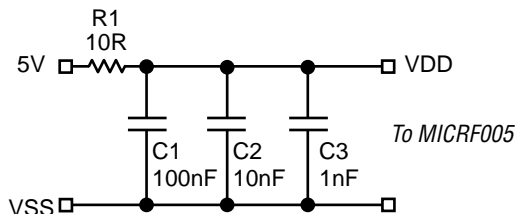

Figure 8. Supply Bypassing

External Timing Signals

Externally applied signals should be ac-coupled and the amplitude must be limited to approximately 0.5Vpp.

Optional BandPass Filter

For applications located in high ambient noise environments, a fixed value band-pass network may be connected between the ANT pin and V_{SSRF} to provide additional receive selectivity and input overload protection.

Frequency and Capacitor Selection

Selection of the reference oscillator frequency f_T , slicing level capacitor (C_{TH}), and AGC capacitor (C_{AGC}) are briefly summarized in this section.

Selecting Reference Oscillator Frequency f_T

As with any superheterodyne receiver, the difference between the internal LO (local oscillator) frequency f_{LO} and the incoming transmit frequency f_{TX} ideally must equal the IF center frequency. Equation 1 may be used to compute the appropriate f_{LO} for a given f_{TX} :

$$(1) \quad f_{LO} = f_{TX} \pm \left(2.496 \frac{f_{TX}}{915} \right)$$

Frequencies f_{TX} and f_{LO} are in MHz. Note that two values of f_{LO} exist for any given f_{TX} , distinguished as “high-side mixing” and “low-side mixing,” and there is generally no preference of one over the other.

After choosing one of the two acceptable values of f_{LO} , use Equation 2 to compute the reference oscillator frequency f_T :

$$(2) \quad f_T = \frac{f_{LO}}{64}$$

Equations (1) and (2) can be simplified to:

$$f_T = 63.8258 f_{TX}$$

Frequency f_T is in MHz. Connect a series-mode crystal of frequency f_T to REFOSC on the MICRF005. Four-decimal-

place accuracy on the frequency is generally adequate. The following table identifies f_T for some common transmit frequencies when the MICRF005 is operated.

Transmit Frequency (f_{TX})	Reference Oscillator Frequency (f_T)
868.35MHz	13.6050MHz
915MHz	14.3359MHz
916.5MHz	14.3594MHz

Table 2. Common Transmitter Frequencies

Selecting Capacitor C_{TH}

The first step in the process is selection of a data-slicing-level time constant. This selection is strongly dependent on system issues including system decode response time and data code structure (that is, existence of data preamble, etc.). This issue is covered in more detail in “Application Note 22.”

Source impedance of the C_{TH} pin is given by equation (3), where f_T is in MHz:

$$(3) \quad R_{SC} = 30\Omega \frac{14.3359}{f_T}$$

Assuming that a slicing level time constant τ has been established, capacitor C_{TH} may be computed using equation (4).

$$(4) \quad C_{TH} = \frac{\tau}{R_{SC}}$$

A standard $\pm 20\%$ X7R ceramic capacitor is generally sufficient.

Selecting C_{AGC} Capacitor in Continuous Mode

Selection of C_{AGC} is dictated by minimizing the ripple on the AGC control voltage by using a sufficiently large capacitor. Factory experience suggests that C_{AGC} should be in the vicinity of 0.47 μ F to 4.7 μ F. Large capacitor values should be carefully considered as this determines the time required for the AGC control voltage to settle from a completely discharged condition. AGC settling time from a completely discharged (zero-volt) state is given approximately by equation (5):

$$(5) \quad \Delta t = 1.333 C_{AGC} - 0.44$$

where:

C_{AGC} is in μ F, and Δt is in seconds.

Selecting C_{AGC} Capacitor in Duty-Cycle Mode

Generally, droop of the AGC control voltage during shutdown should be replenished as quickly as possible after the IC is “turned-on”. As described in the functional description, for about [tbd]ms after the IC is turned on, the AGC push-pull currents are increased to 45 times their normal values. Consideration should be given to selecting a value for C_{AGC} and a shutdown time period such that the droop can be replenished within this [tbd]ms period.

Polarity of the droop is unknown, meaning the AGC voltage could droop up or down. Worst-case from a recovery standpoint is downward droop, since the AGC pullup current is 1/10th magnitude of the pulldown current. The downward droop is replenished according to the Equation (6):

$$(6) \quad \frac{I}{C_{AGC}} = \frac{\Delta V}{\Delta t}$$

where:

I = AGC pullup current for the initial [tbd]ms (67.5 μ A)

C_{AGC} = AGC capacitor value

Δt = droop recovery time

ΔV = droop voltage

For example, if user desires $\Delta t = 10$ ms and chooses a 4.7 μ F C_{AGC} , then the allowable droop is about 144mV. Using the same equation with 200nA worst case pin leakage and assuming 1 μ A of capacitor leakage in the same direction, the maximum allowable Δt (shutdown time) is about 0.56s for droop recovery in 10ms.

Typical Applications

Figure 9 below illustrates a typical application for the MICRF005 UHF receiver IC. Operation in this example is at 916.5MHz

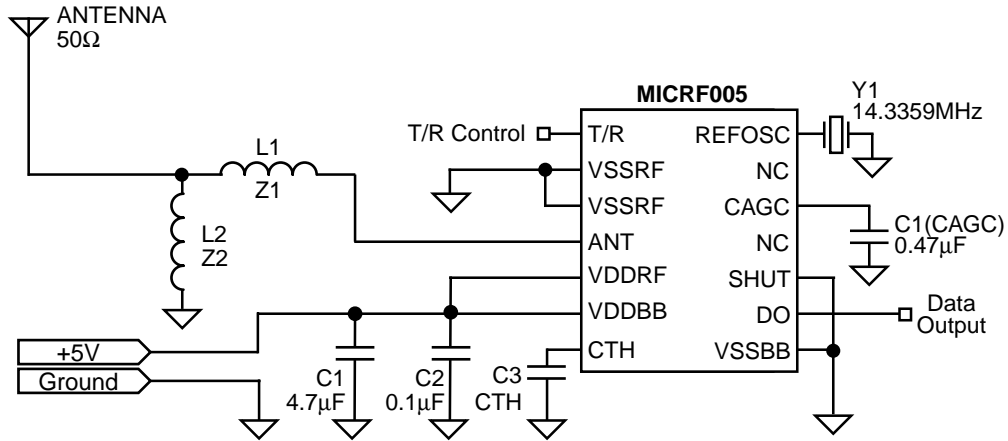

Bill of Materials

Item	Part Number	Manufacturer	Description	Qty
U1	MICRF005	Micrel	UHF Receiver	1
C1, C4		Panasonic	4.7μF Ceramic Cap	1
C2		Panasonic	0.47μF Ceramic Cap	1
C3		Panasonic	0.1μF Ceramic Cap	1
L1, L2		Coilcraft	[tbd]nH, Wire wound SMT inductors	1
Y1			13.3594MHz crystal	1

Package Information

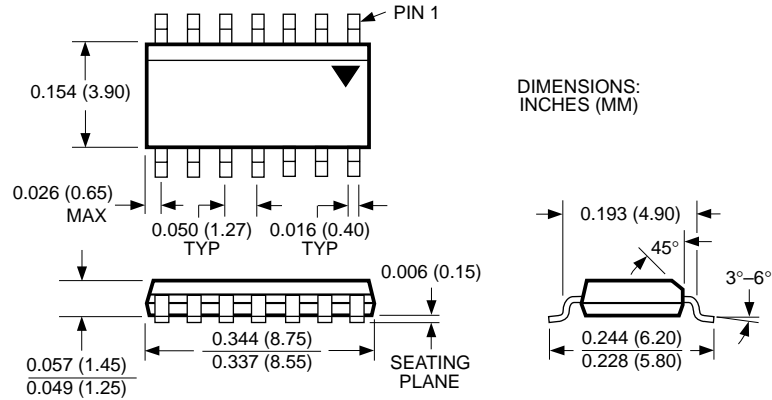

DIMENSIONS:
INCHES (MM)

14-Lead SOIC (M)

MICREL INC. 1849 FORTUNE DRIVE SAN JOSE, CA 95131 USA

TEL + 1 (408) 944-0800 FAX + 1 (408) 944-0970 WEB <http://www.micrel.com>

This information is believed to be accurate and reliable, however no responsibility is assumed by Micrel for its use nor for any infringement of patents or other rights of third parties resulting from its use. No license is granted by implication or otherwise under any patent or patent right of Micrel Inc.

© 2001 Micrel Incorporated



Компания «ЭлектроПласт» предлагает заключение долгосрочных отношений при поставках импортных электронных компонентов на взаимовыгодных условиях!

Наши преимущества:

- Оперативные поставки широкого спектра электронных компонентов отечественного и импортного производства напрямую от производителей и с крупнейших мировых складов;
- Поставка более 17-ти миллионов наименований электронных компонентов;
- Поставка сложных, дефицитных, либо снятых с производства позиций;
- Оперативные сроки поставки под заказ (от 5 рабочих дней);
- Экспресс доставка в любую точку России;
- Техническая поддержка проекта, помощь в подборе аналогов, поставка прототипов;
- Система менеджмента качества сертифицирована по Международному стандарту ISO 9001;
- Лицензия ФСБ на осуществление работ с использованием сведений, составляющих государственную тайну;
- Поставка специализированных компонентов (Xilinx, Altera, Analog Devices, Intersil, Interpoint, Microsemi, Aeroflex, Peregrine, Syfer, Eurofarad, Texas Instrument, Miteq, Cobham, E2V, MA-COM, Hittite, Mini-Circuits, General Dynamics и др.);

Помимо этого, одним из направлений компании «ЭлектроПласт» является направление «Источники питания». Мы предлагаем Вам помощь Конструкторского отдела:

- Подбор оптимального решения, техническое обоснование при выборе компонента;
- Подбор аналогов;
- Консультации по применению компонента;
- Поставка образцов и прототипов;
- Техническая поддержка проекта;
- Защита от снятия компонента с производства.

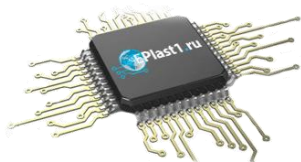

Как с нами связаться

Телефон: 8 (812) 309 58 32 (многоканальный)

Факс: 8 (812) 320-02-42

Электронная почта: org@eplast1.ru

Адрес: 198099, г. Санкт-Петербург, ул. Калинина, дом 2, корпус 4, литера А.