

Programmable Loop-Powered Temperature Measuring Transducer MCR-FL-HT-T-I

1. Brief Description

- For resistance thermometers, thermocouples, and resistance and voltage sensors
- For installation in Form B connection head
- Can be freely programmed using the MCR-PI-CONF-WIN configuration software (Order No. 28 14 79 9)

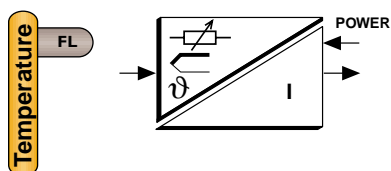

Universal **PC programmable temperature measuring transducers** convert temperature signals from resistance thermometers and thermocouples as well as sensors with linear mV characteristic curves to analog 4...20 mA signals.

On the output side the temperature measuring transducers are operated in a 4...20 mA current loop, which simultaneously provides the module with the required power for signal conversion.

To change the configuration data, use the MCR-PAC-T programming adapter (Order No. 28 64 59 0) and the Windows-compatible MCR-PI-CONF-WIN configuration software (Order No. 28 14 79 9).

Customized measuring range settings and an extended setup can thus be implemented.

Failure information in the event of sensor breaks or sensor short circuit can be set according to NE 43. This measuring transducer maintains a high level of accuracy throughout the entire ambient operating temperature range.

The devices are supplied with the following default configuration: PT100 sensor, 0...100°C (32...212°F) measuring range, 3-wire termination.

Dimensional drawing for MCR-FL-HT-T-I

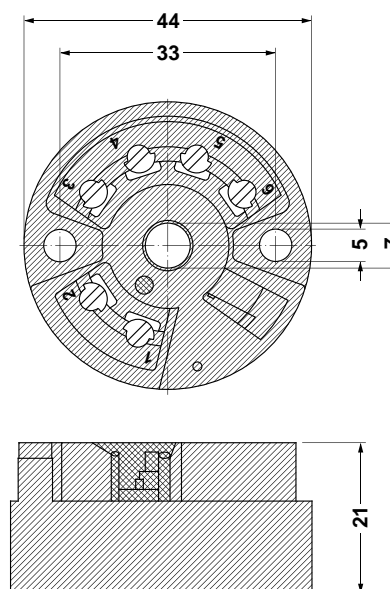

Programmable Loop-Powered Temperature Measuring Transducer - MCR-FL-HT-T-I

1.1. Input Signals			
Resistance thermometer (RTD)	Designation	Measuring Range Limits	Minimum Measuring Span
	Pt100 Pt500 Pt1000 according to IEC 751	-200 to +850°C (-328 to +1562°F) -200 to +250°C (-328 to +482°F) -200 to +250°C (-328 to +482°F)	10 K 10 K 10 K
	Ni100 Ni500 Ni1000 according to DIN 43760	-60 to +250°C (-76 to +482°F) -60 to +150°C (-76 to +302°F) -60 to +150°C (-76 to +302°F)	10 K 10 K 10 K
<ul style="list-style-type: none"> • Connection type: 2, 3 or 4-wire termination • With 2-wire termination, the cable resistance can be compensated (0...20 Ω). • With 3 and 4-wire termination, sensor cable resistance up to a maximum of 11 Ω per cable • Sensor current ≤ 0.6 mA 			
Resistance sensor	Resistance (Ω)	10...400 Ω 10...2000 Ω	10 Ω 100 Ω
Thermocouple (TC)	Designation	Measuring Range Limits	Minimum Measuring Span
	B (PtRh30-PtRh6) C (W5Re-W26Re) ¹⁾ D (W3Re-W25Re) ¹⁾ E (NiCr-CuNi) J (Fe-CuNi) K (NiCr-Ni) L (Fe-CuNi) ²⁾ N (NiCrSi-NiSi) R (PtRh13-Pt) S (PtRh10-Pt) T (Cu-CuNi) U (Cu-CuNi) ²⁾ MoRe5-MoRe4 ³⁾ according to IEC 584 Part 1	0 to +1820°C (+32 to +3308°F) 0 to +2320°C (+32 to 4208°F) 0 to +2495°C (+32 to +4523°F) -200 to +915°C (-328 to +1679°F) -200 to +1200°C (-328 to 2192°F) -270 to +1372°C (-454 to +2501°F) -200 to +900°C (-328 to +1652°F) -270 to +1300°C (-454 to +2372°F) 0 to +1768°C (+32 to +3214°F) -50 to +1768°C (-58 to +3214°F) -200 to +400°C (-328 to +752°F) -200 to +600°C (-328 to +1112°F) 0 to +2000°C (+32 to +3632°F)	500 K 500 K 500 K 50 K 50 K 50 K 50 K 50 K 50 K 500 K 500 K 50 K 50 K 50 K 500 K
<ul style="list-style-type: none"> • Cold junction: internal (Pt100) or external (0...80°C [32...176°F]) • Cold junction accuracy: ±1 K 			
Voltage sensor (mV)	Millivolt sensor (mV)	-10...100 mV	5 mV

¹⁾ According to ASTM E988

²⁾ According to DIN 43710

³⁾ No specification

2. Technical Data

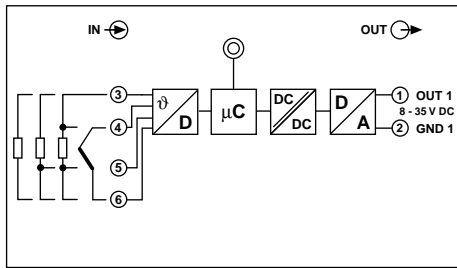

M 3

8 mm (0.31 in.)

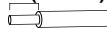

solid flexible
[mm²] AWG

Connection data 0.2 - 1.75 0.2 - 1.75 24 - 16

Description

MCR temperature measuring transducer, for resistance thermometers, thermocouples, and resistance and voltage sensors

Technical Data

Input

Output

Output signal
Maximum output signal
Load
Output signal in the event of open circuit/short circuit ¹⁾
Measuring range exceeded/not reached

MCR-FL-HT-T-I

Programmable loop-powered temperature measuring transducer



Type	Order No.	Pcs. Pkt.
MCR-FL-HT-T-I	28 64 52 9	1

- PT100, PT500, PT1000 and Ni100, Ni500, Ni1000 resistance thermometers, in 2, 3 or 4-wire technology, minimum measuring span of 10 K
- Thermocouple sensors (B, C, D, E, J, K, L, N, R, S, T, U); minimum measuring span of 50 K/500 K
- Linear mV signals from -10 mV to +100 mV; minimum measuring span of 5 mV
- Resistance sensor of 10 Ω to 400 Ω and 10 Ω to 2000 Ω; minimum measuring span of 10 Ω/100 Ω

4...20 mA/20...4 mA
≤ 25 mA
(V_{Supply} - 8 V)/0.025 A, maximum
≤ 3.6 mA/≥ 21.0 mA
≤ 20.5 mA/≥ 3.8 mA (linear increase/drop)

Programmable Loop-Powered Temperature Measuring Transducer - MCR-FL-HT-T-I

General Data	
Supply voltage	8...35 V DC
Maximum current consumption	< 3.5 mA
Transmission error ²⁾	Resistance thermometer (RTD)
	0.2 K or 0.08% (Pt100, Ni100), 0.5 K or 0.20% (Pt500, Ni500), 0.3 K or 0.12% (Pt1000, Ni1000)
	Thermocouple (TC) ⁵⁾
	0.5 K or 0.08% (K, J, T, E, L, U), typical, 1.0 K or 0.08% (N, C, D), typical, 2.0 K or 0.08% (S, B, R, MoRe5-MoRe41), typical
	Resistance sensor (Ω)
	±0.1 Ω or 0.08% (10...400 Ω), ±1.5 Ω or 0.12% (10...2000 Ω), ±20 μV or 0.08% (-10...100 mV)
	Voltage sensor (mV)
Influence of the ambient temperature (temperature drift)	<ul style="list-style-type: none"> Resistance thermometer (RTD): $T_d = \pm (15 \text{ ppm/K} \cdot \text{maximum measuring range} + 50 \text{ ppm/K} \cdot \text{set measuring range}) \cdot \Delta t^3$ Pt100 resistance thermometer: $T_d = \pm (15 \text{ ppm/K} \cdot (\text{measuring range final value} + 200) + 50 \text{ ppm/K} \cdot \text{set measuring range}) \cdot \Delta t^3$ Thermocouple (TC): $T_d = \pm (50 \text{ ppm/K} \cdot \text{maximum measuring range} + 50 \text{ ppm/K} \cdot \text{set measuring range}) \cdot \Delta t^3$
Influence of the load ⁴⁾	≤ ±0.02%/100 Ω
Influence of the supply voltage ⁴⁾	≤ ±0.01%/V deviation of 24 V
Response time	< 2 s
On delay	6 s
Test voltage	2 kV AC, 50 Hz, 1 minute
Ambient operating temperature range	-40°C to +85°C (-40°F to +185°F)
Storage temperature	-40°C to +100°C (-40°F to +212°F)
Climatic category	According to EN60 654-1, Class C
Condensation	Permissible
Degree of protection	IP 00, IP 66 (installed in connection head)
Mounting location	Any
Mounting position	Connection head according to DIN 43 729 Form B
Resistance to shock and vibration	4 g/2...150 Hz according to IEC 60 068-2-6
Configuration	Using MCR-PI-CONF-WIN configuration software package
Electromagnetic compatibility	CE Conformance with EMC Directive 89/336/EEC
• Noise emission and noise immunity	EN 61 326-1 (IEC 1326) and NAMUR NE 21
Housing material	Polycarbonate (PC), sealing material (PUR)
Weight	40 g, approximately

3. CE Conformance With EMC Directive 89/336/EEC

The measuring system meets the legal requirements of EU directives. Phoenix Contact indicates that the device has been successfully tested through the use of the c mark.

EMC (Electromagnetic Compatibility):

Noise immunity and noise emission according to EN 61 326-1 (IEC 1326) and NAMUR NE 21.

¹⁾ Not for thermocouples

²⁾ % refers to the set measuring span.

³⁾ Δt = Difference between the ambient temperature and the reference condition

⁴⁾ All data refers to the measuring range final value of 20 mA

⁵⁾ Influence of the internal cold junction Pt100 DIN IEC 751 Kl.B

4. Connections

2-Wire Connection

For short distances.

Please note: The cable resistances directly affect the measuring result and falsify it, provided that they are not compensated by the software.

3-Wire Connection

For long distances between the resistance thermometer and the MCR module and equal cable resistances ($R_{L1} = R_{L2} = R_{L3}$).

Please note: The cable resistance per wire must not exceed 11Ω .

4-Wire Connection

For long distances between the resistance thermometer and the MCR module and varied cable resistances ($R_{L1} \neq R_{L2} \neq R_{L3} \neq R_{L4}$).

Please note: The cable resistance per wire must not exceed 11Ω . The permissible residual ripple is $U_{pp} \leq 5\text{ V}$ at $U_b \geq 13\text{ V}$, and $f_{max.}$ of 1 kHz.

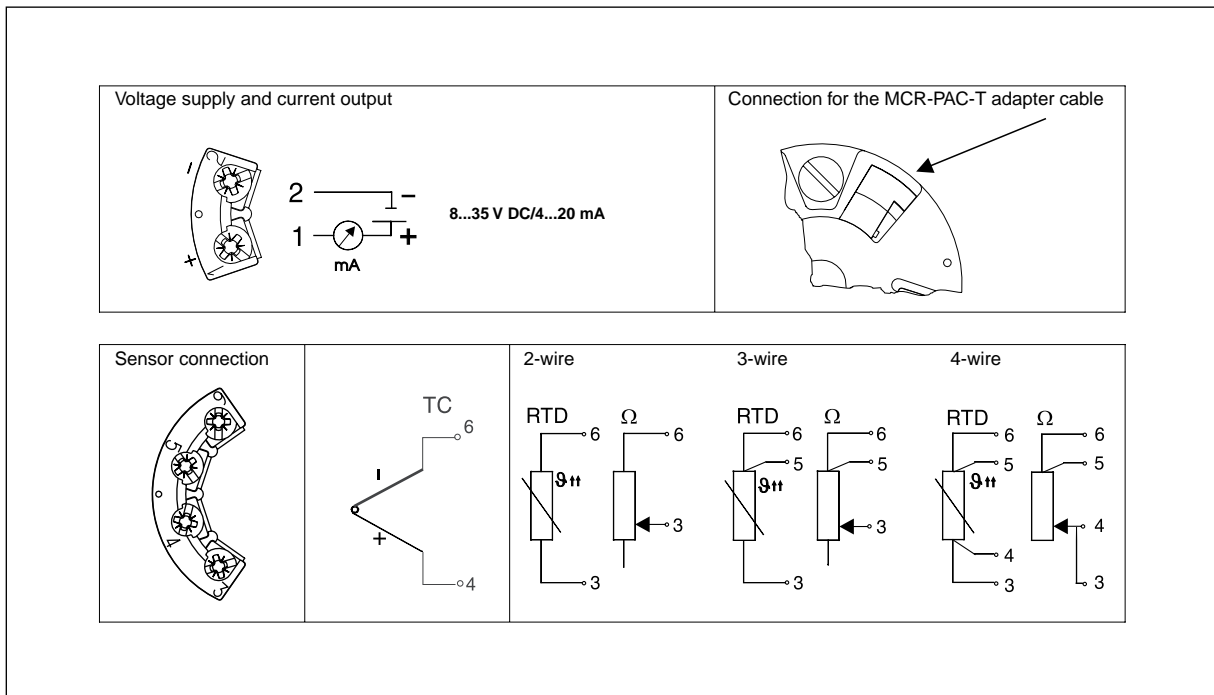
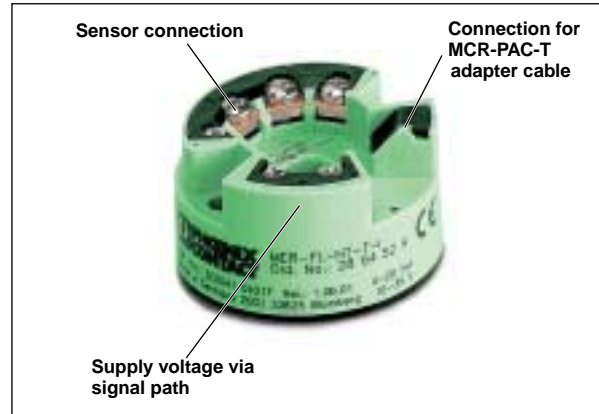

5. Installation in the Sensor Connection Head According to DIN 43 729 Form B

1. Cover
2. Mounting screws
3. Mounting springs
4. Temperature measuring transducer
5. Sensor insert with connection wires
6. Circlips
7. Cable gland

- Insert the connection wires of the sensor insert in the central drill hole of the measuring transducer
- Place the mounting springs on the mounting screws
- Insert the mounting screws in the drill holes of the measuring transducer and the drill holes of the sensor insert. Secure both mounting screws with the circlips
- Position the measuring transducer in the connection head so that the connection terminals for the current output (terminals 1 and 2) point to the cable gland.
- Then secure the measuring transducer to the sensor insert in the connection head.



Do not secure the mounting screws too tightly as this may damage the measuring transducer.

6. Configuration

The devices are supplied with the following default configuration: PT100 sensor, 0...100°C (32...212°F) measuring range, 3-wire termination.

To change the configuration data, use the MCR-PAC-T programming adapter (Order No. 28 64 59 0) and the Windows-compatible MCR-PI-CONF-WIN configuration software (Order No. 28 14 79 9). Customized measuring range settings and an extended setup can be implemented. In addition, the online help explains the configuration options and their implementation.

Configurable Parameters:

- Sensor type and connection type
- Unit of measurement (°C/°F)
- Measuring ranges
- Internal/external cold junction
- Compensation of the cable resistance for 2-wire termination
- Errors
- Output signal (4...20mA/20...4mA)
- Attenuation
- Offset
- Designation for measuring points (8 characters)
- Output simulation

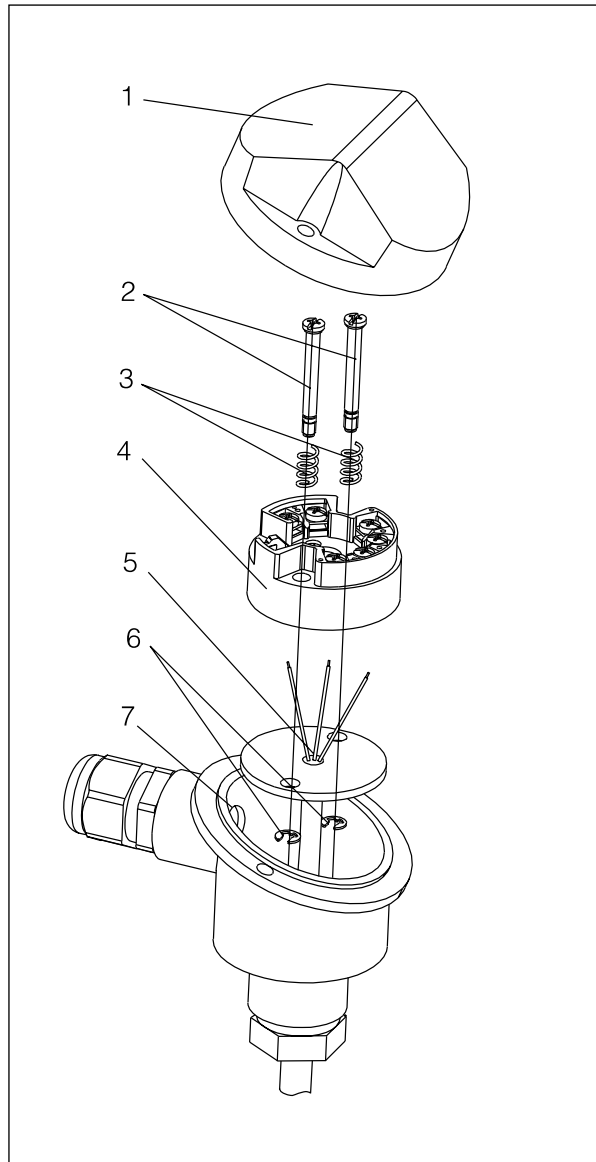

7. Application Examples

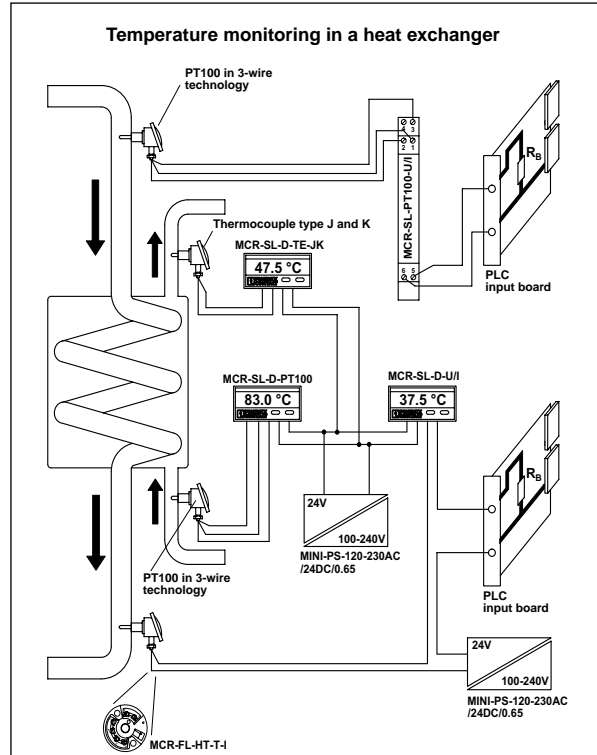
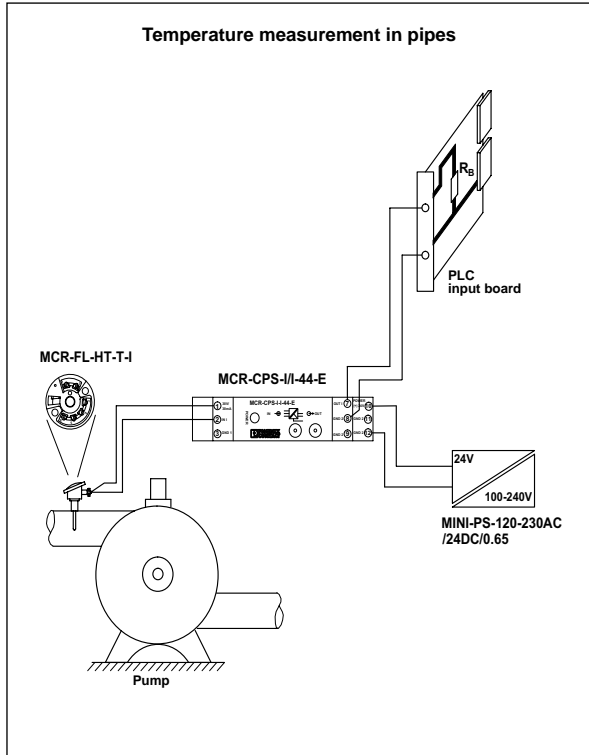



Компания «ЭлектроПласт» предлагает заключение долгосрочных отношений при поставках импортных электронных компонентов на взаимовыгодных условиях!

Наши преимущества:

- Оперативные поставки широкого спектра электронных компонентов отечественного и импортного производства напрямую от производителей и с крупнейших мировых складов;
- Поставка более 17-ти миллионов наименований электронных компонентов;
- Поставка сложных, дефицитных, либо снятых с производства позиций;
- Оперативные сроки поставки под заказ (от 5 рабочих дней);
- Экспресс доставка в любую точку России;
- Техническая поддержка проекта, помощь в подборе аналогов, поставка прототипов;
- Система менеджмента качества сертифицирована по Международному стандарту ISO 9001;
- Лицензия ФСБ на осуществление работ с использованием сведений, составляющих государственную тайну;
- Поставка специализированных компонентов (Xilinx, Altera, Analog Devices, Intersil, Interpoint, Microsemi, Aeroflex, Peregrine, Syfer, Eurofarad, Texas Instrument, Miteq, Cobham, E2V, MA-COM, Hittite, Mini-Circuits, General Dynamics и др.);

Помимо этого, одним из направлений компании «ЭлектроПласт» является направление «Источники питания». Мы предлагаем Вам помощь Конструкторского отдела:

- Подбор оптимального решения, техническое обоснование при выборе компонента;
- Подбор аналогов;
- Консультации по применению компонента;
- Поставка образцов и прототипов;
- Техническая поддержка проекта;
- Защита от снятия компонента с производства.



Как с нами связаться

Телефон: 8 (812) 309 58 32 (многоканальный)

Факс: 8 (812) 320-02-42

Электронная почта: org@eplast1.ru

Адрес: 198099, г. Санкт-Петербург, ул. Калинина, дом 2, корпус 4, литера А.