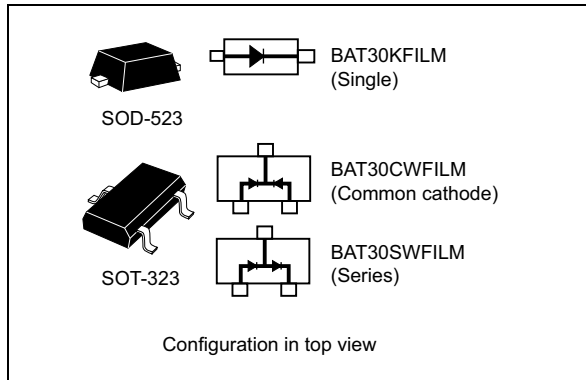

Small signal Schottky diodes

Datasheet - production data

Description

The BAT30 series uses 30 V Schottky barrier diodes encapsulated in SOD-523 or SOT-323 packages.

This device is specially suited for switching mode applications needing low forward voltage drop diodes.

Features

- Very low conduction losses
- Negligible switching losses
- Low forward and reverse recovery times
- Extremely fast switching
- Surface mount device
- Low capacitance diode
- ECOPACK[®]2 and RoHS compliant component

Table 1. Device summary

Symbol	Value
I_F	300 mA
V_{RRM}	30 V
C (typ.)	14 pF
T_j (max.)	150 °C

1 Characteristics

Table 2. Absolute ratings (limiting values at $T_{amb} = 25\text{ °C}$, unless otherwise specified)

Symbol	Parameter		Value	Unit
V_{RRM}	Repetitive peak reverse voltage		30	V
I_F	Continuous forward current		300	mA
I_{FSM}	Surge non repetitive forward current	$t_p = 10\text{ ms}$ Sinusoidal	1	A
I_{FRM}	Repetitive peak forward current, square wave	$T_A = 85\text{ °C}$, $\delta = 0.1$	0.9	A
$P_D^{(1)}$	Power dissipation	SOT-323	225	mW
		SOD-523	200	
T_{stg}	Storage temperature range		-65 to +150	°C
T_J	Maximum operating junction temperature		150	°C
T_L	Maximum soldering temperature		260	°C

1. On epoxy printed circuit board with recommended pad layout

Table 3. Thermal parameters

Symbol	Parameter		Value	Unit
$R_{th(j-a)}$	Junction to ambient ⁽¹⁾	SOT-323	550	°C/W
		SOD-523	600	

1. On epoxy printed circuit board with recommended pad layout

Table 4. Static electrical characteristics

Symbol	Parameter	Test conditions	Min.	Typ.	Max.	Unit	
$I_R^{(1)}$	Reverse leakage current	$T_j = 25\text{ }^\circ\text{C}$	$V_R = 5\text{ V}$	-		0.5	μA
			$V_R = 10\text{ V}$	-		1	
			$V_R = 25\text{ V}$	-	0.65	3	
			$V_R = 30\text{ V}$	-		5	
		$T_j = 70\text{ }^\circ\text{C}$	$V_R = 10\text{ V}$	-	7	20	
		$T_j = 85\text{ }^\circ\text{C}$		-	18	50	
$V_F^{(2)}$	Forward voltage drop	$T_j = 25\text{ }^\circ\text{C}$	$I_F = 0.1\text{ mA}$	-		240	mV
			$I_F = 1\text{ mA}$	-		300	
			$I_F = 10\text{ mA}$	-		375	
			$I_F = 30\text{ mA}$	-		430	
			$I_F = 100\text{ mA}$	-		500	
			$I_F = 200\text{ mA}$	-		580	
			$I_F = 300\text{ mA}$	-	530		

1. Pulse test: $t_p = 5\text{ ms}$, $\delta < 2\%$

2. Pulse test: $t_p = 380\text{ }\mu\text{s}$, $\delta < 2\%$

Table 5. Dynamic characteristics

Symbol	Parameter	Test conditions	Min.	Typ.	Max.	Unit
C	Diode capacitance	$V_R = 0\text{ V}$, $F = 1\text{ MHz}$	-	22	-	pF
		$V_R = 1\text{ V}$, $F = 1\text{ MHz}$	-	14	-	
		$V_R = 10\text{ V}$, $F = 1\text{ MHz}$	-	6	-	

Figure 1. Power dissipation versus average forward current

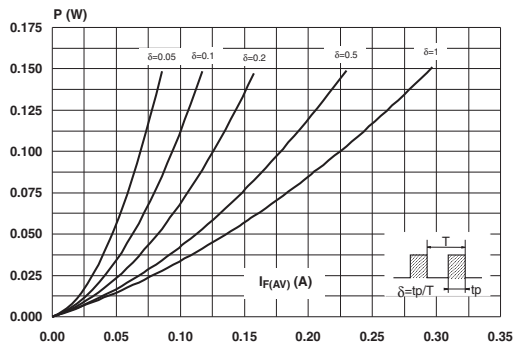

Figure 2. Continuous forward current versus ambient temperature

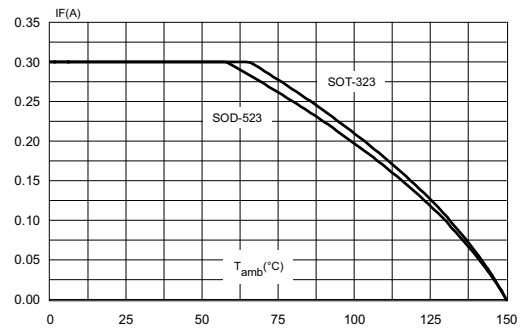

Figure 3. Relative variation of thermal impedance junction to ambient versus pulse duration

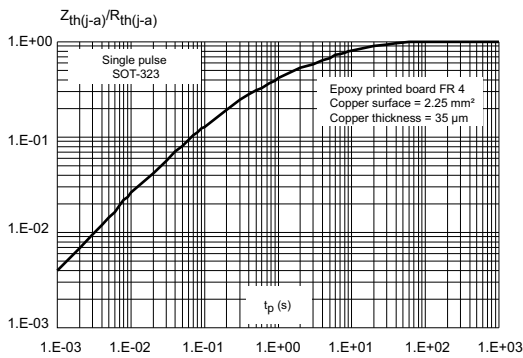

Figure 4. Relative variation of thermal impedance junction to ambient versus pulse duration

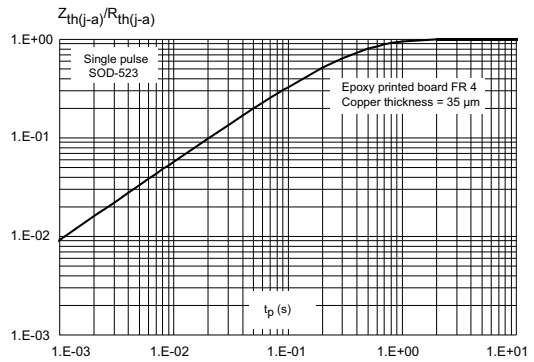

Figure 5. Leakage current versus reverse applied voltage (typical values)

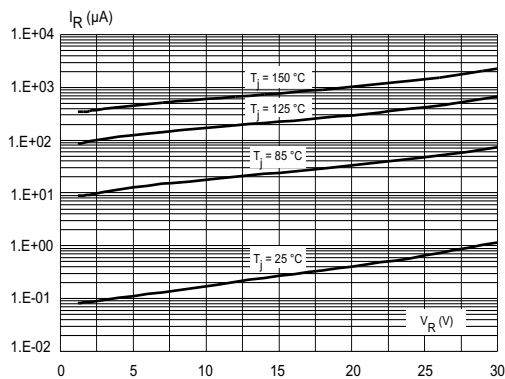

Figure 6. Relative variation of reverse leakage current versus junction temperature (typical values)

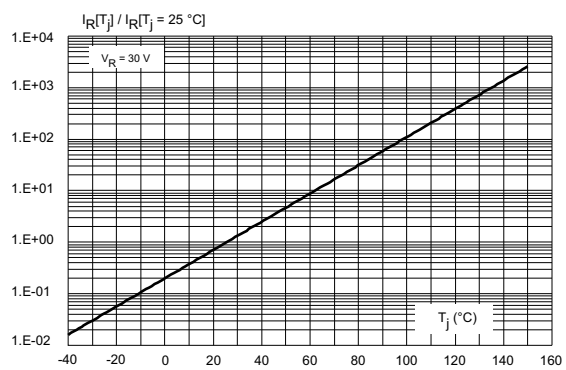

Figure 7. Junction capacitance versus reverse applied voltage (typical values)

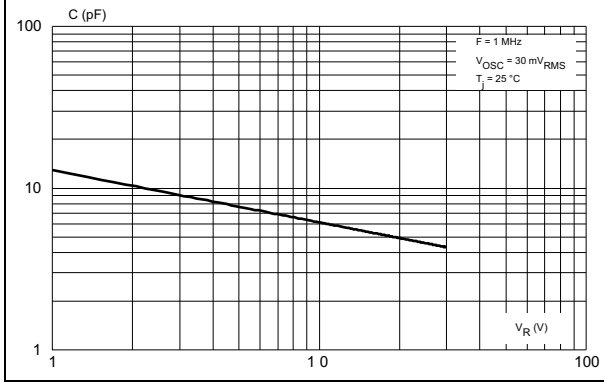

Figure 8. Forward voltage drop versus forward current (typical values)

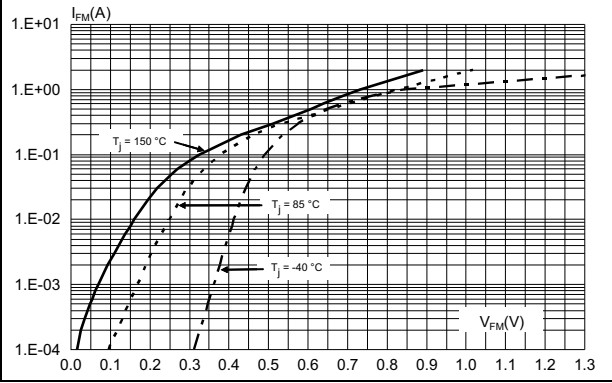
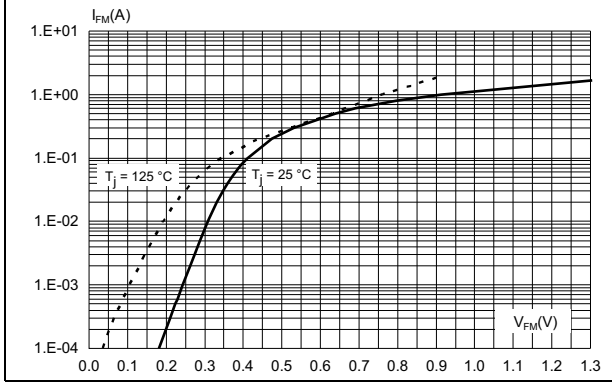

Figure 9. Forward voltage drop versus forward current (typical values)



2 Package information

- Epoxy meets UL94, V0
- Lead-free packages

In order to meet environmental requirements, ST offers these devices in different grades of ECOPACK® packages, depending on their level of environmental compliance. ECOPACK® specifications, grade definitions and product status are available at: www.st.com. ECOPACK® is an ST trademark.

2.1 SOD-523 package information

Figure 10. SOD-523 package outline

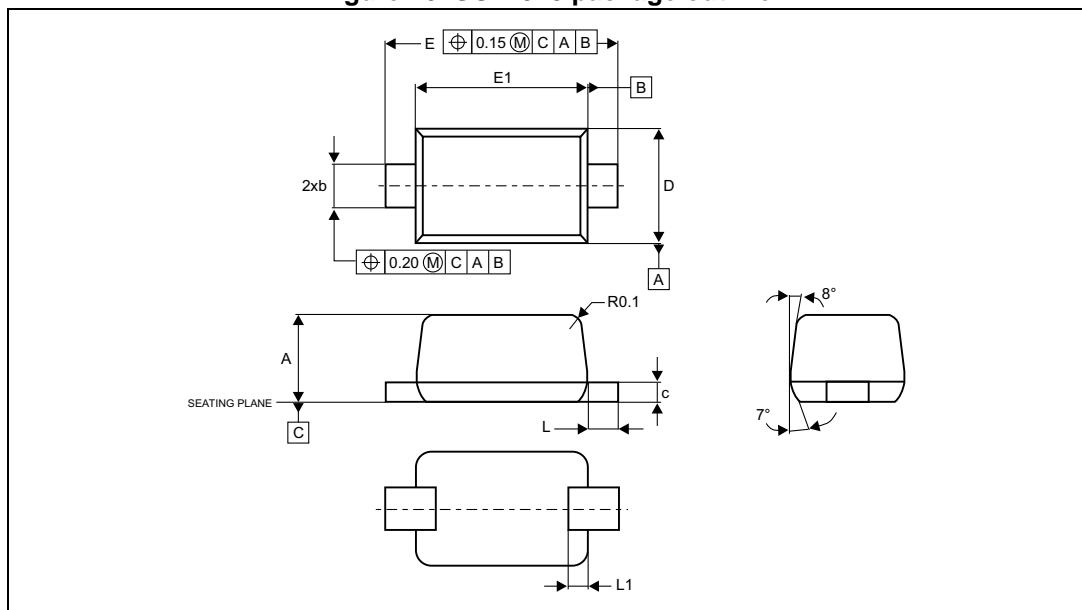
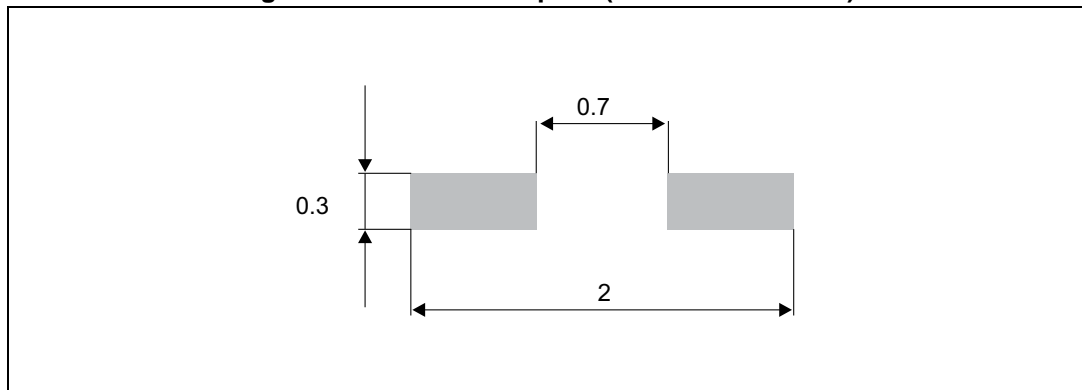

Table 6. SOD-523 package mechanical data

Ref.	Dimensions					
	Millimeters			Inches ⁽¹⁾		
	Typ.	Min.	Max.	Typ.	Min.	Max.
A	0.60	0.50	0.70	0.024	0.020	0.028
E	1.60	1.50	1.70	0.063	0.059	0.067
E1	1.20	1.10	1.30	0.047	0.043	0.051
D	0.80	0.70	0.90	0.031	0.028	0.035
b	-	0.25	0.35	-	0.010	0.014
c	-	0.07	0.20	-	0.003	0.008
L	0.20	0.15	0.25	0.008	0.006	0.010
L1	-	0.05	0.20	-	0.002	0.008

1. Values in inches are converted from mm and rounded to 4 decimal digits.

Figure 11. SOD-523 footprint (dimensions in mm)



2.2 SOT-323 package information

Figure 12. SOT-323 package outline

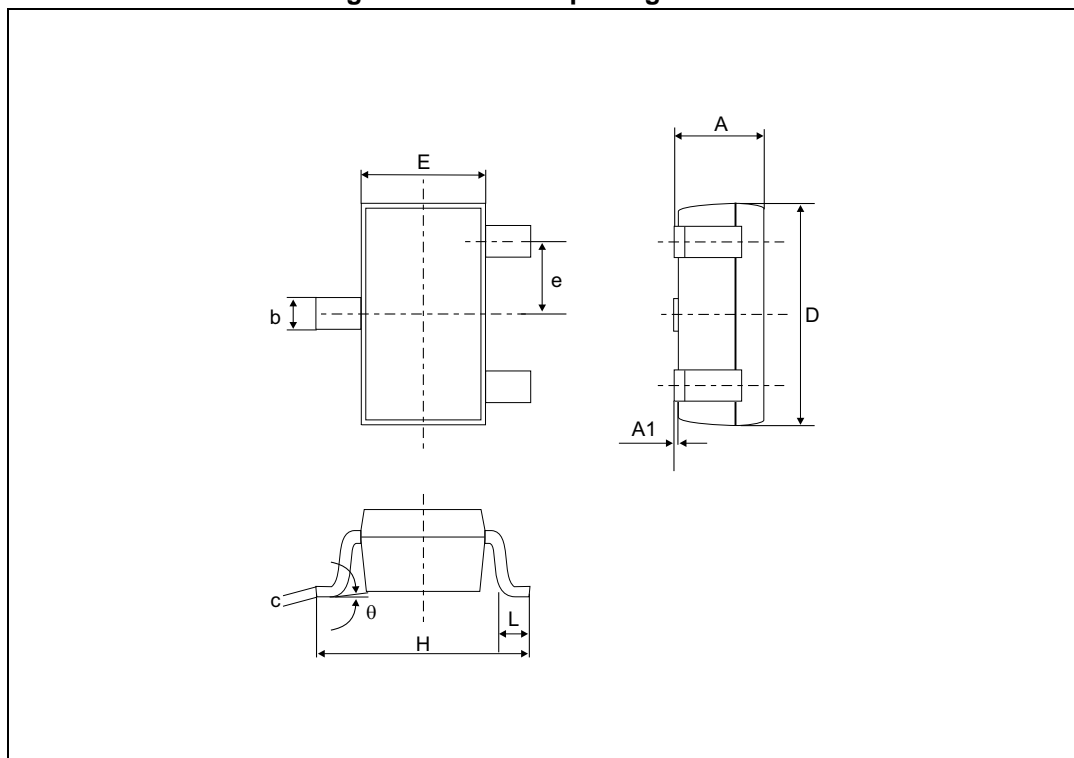
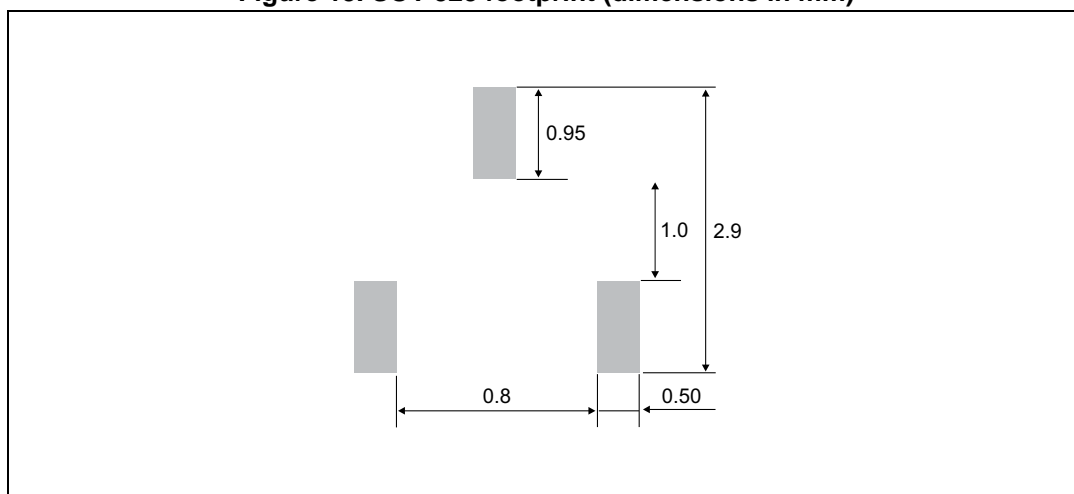

Table 7. SOT-323 package mechanical data

Ref.	Dimensions					
	Millimeters			Inches ⁽¹⁾		
	Typ.	Min.	Max.	Typ.	Min.	Max.
A	-	0.8	1.1	-	0.031	0.043
A1	-	0.0	0.1	-	0.0	0.004
b	-	0.25	0.4	-	0.010	0.016
c	-	0.1	0.26	-	0.004	0.010
D	2.0	1.8	2.2	0.079	0.071	0.086
E	1.25	1.15	1.35	0.049	0.045	0.053
e	0.65	-	-	0.026	-	-
H	2.1	1.8	2.4	0.083	0.071	0.094
L	0.2	0.1	0.3	0.008	0.004	0.012
q	-	0	30°	-	0	30°

1. Values in inches are converted from mm and rounded to 4 decimal digits.

Figure 13. SOT-323 footprint (dimensions in mm)



3 Ordering information

Table 8. Ordering information

Order code	Marking	Package	Weight	Base qty.	Packing mode
BAT30CWFILM	C30	SOT-323 Common cathode	6 mg	3000	Tape and reel
BAT30KFILM	30	SOD-523 Single	1.45 mg	3000	Tape and reel
BAT30SWFILM	S30	SOT-323 Serial	6 mg	3000	Tape and reel

Figure 14. Ordering information scheme

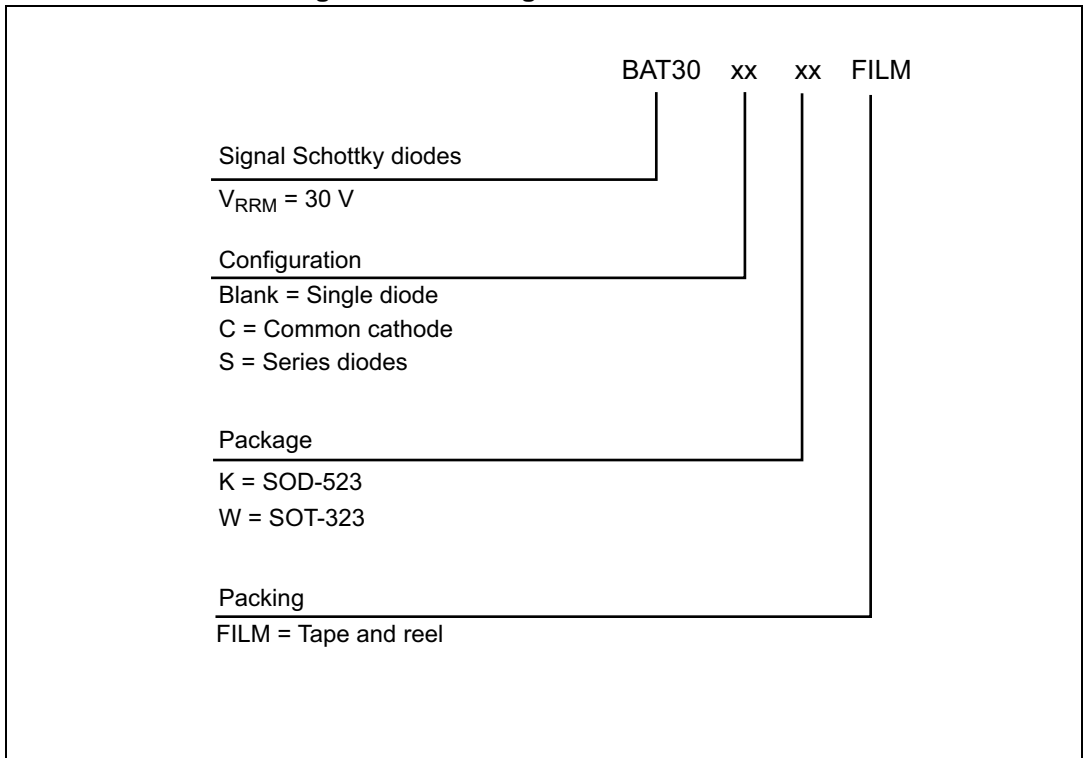

4 Revision history

Table 9. Document revision history

Date	Revision	Changes
24-Jul-2006	1	First issue
08-Jul-2009	2	Added SOD-923 package. Table 12 sorted on alphabetic sequence of order code. Updated ECOPACK statement.
13-Oct-2009	3	Updated Table 6 quote "L1" from 0.10 to 0.05.
01-Apr-2014	4	Added Pin 1 anode marker to SOT-666 package graphics. Updated Table 2: Absolute ratings (limiting values at $T_{amb} = 25\text{ °C}$, unless otherwise specified) .
01-Apr-2015	5	Package information updated and removed: SOD-323, SOD-923, SOT-23 and SOT666. Updated cover page. Updated Table 2 and Table 3 . Updated Figure 14 and Figure 3 . Format updated to current standard.

IMPORTANT NOTICE – PLEASE READ CAREFULLY

STMicroelectronics NV and its subsidiaries (“ST”) reserve the right to make changes, corrections, enhancements, modifications, and improvements to ST products and/or to this document at any time without notice. Purchasers should obtain the latest relevant information on ST products before placing orders. ST products are sold pursuant to ST’s terms and conditions of sale in place at the time of order acknowledgement.

Purchasers are solely responsible for the choice, selection, and use of ST products and ST assumes no liability for application assistance or the design of Purchasers’ products.

No license, express or implied, to any intellectual property right is granted by ST herein.

Resale of ST products with provisions different from the information set forth herein shall void any warranty granted by ST for such product.

ST and the ST logo are trademarks of ST. All other product or service names are the property of their respective owners.

Information in this document supersedes and replaces information previously supplied in any prior versions of this document.

© 2015 STMicroelectronics – All rights reserved



Компания «ЭлектроПласт» предлагает заключение долгосрочных отношений при поставках импортных электронных компонентов на взаимовыгодных условиях!

Наши преимущества:

- Оперативные поставки широкого спектра электронных компонентов отечественного и импортного производства напрямую от производителей и с крупнейших мировых складов;
- Поставка более 17-ти миллионов наименований электронных компонентов;
- Поставка сложных, дефицитных, либо снятых с производства позиций;
- Оперативные сроки поставки под заказ (от 5 рабочих дней);
- Экспресс доставка в любую точку России;
- Техническая поддержка проекта, помощь в подборе аналогов, поставка прототипов;
- Система менеджмента качества сертифицирована по Международному стандарту ISO 9001;
- Лицензия ФСБ на осуществление работ с использованием сведений, составляющих государственную тайну;
- Поставка специализированных компонентов (Xilinx, Altera, Analog Devices, Intersil, Interpoint, Microsemi, Aeroflex, Peregrine, Syfer, Eurofarad, Texas Instrument, Miteq, Cobham, E2V, MA-COM, Hittite, Mini-Circuits, General Dynamics и др.);

Помимо этого, одним из направлений компании «ЭлектроПласт» является направление «Источники питания». Мы предлагаем Вам помощь Конструкторского отдела:

- Подбор оптимального решения, техническое обоснование при выборе компонента;
- Подбор аналогов;
- Консультации по применению компонента;
- Поставка образцов и прототипов;
- Техническая поддержка проекта;
- Защита от снятия компонента с производства.



Как с нами связаться

Телефон: 8 (812) 309 58 32 (многоканальный)

Факс: 8 (812) 320-02-42

Электронная почта: org@eplast1.ru

Адрес: 198099, г. Санкт-Петербург, ул. Калинина, дом 2, корпус 4, литера А.