

ASMT-YTD2-0BB02

High Brightness Tricolor PLCC6 White Surface Mount LED



Data Sheet



Lead (Pb) Free
RoHS 6 fully
compliant



Description

The high brightness White Surface tri-color PLCC-6 family of SMT LEDs has a separate heat path for each LED dice, enabling the LED to be driven at higher current. These SMT LEDs are in the high brightness category, are high reliability devices, are high performance and are designed for a wide range of environmental conditions. They also provide super wide viewing angle at 120° with the built in reflector pushing up the intensity of the light output. The high reliability characteristics and other features make the White Surface tri-color PLCC-6 family ideally suitable for exterior and interior full color signs application conditions.

For easy pick & place, the LEDs are shipped in EIA-compliant tape and reel. Every reel is shipped from a single intensity and color bin; except red color providing better uniformity. These White Surface tri-color LEDs are compatible with reflow soldering process.

Features

- Industry Standard PLCC-6 package (Plastic Leaded Chip Carrier) with individual addressable pin-out for higher flexibility of driving configuration
- High reliability LED package with silicone encapsulation
- High brightness using AlInGaP and InGaN dice technologies
- Wide viewing angle at 120°
- Compatible with reflow soldering process
- JEDEC MSL 2a
- Water-Resistance (IPX6*) per IEC 60529:2001

* The test is conducted on component level by mounting the components on PCB with proper potting to protect the leads. It is strongly recommended that customers perform necessary tests on the components for their final application.

Applications

- Indoor and outdoor full color sign display
- Gaming machine

CAUTION: LEDs are Class 1C ESD sensitive. Please observe appropriate precautions during handling and processing. Please refer to Avago Application Note AN-1142 for additional details.

Package Dimensions

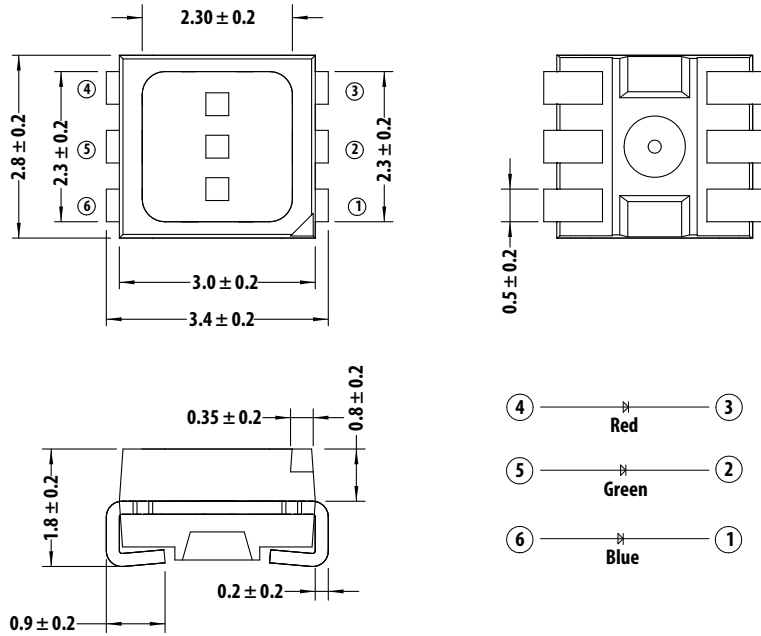

Lead Configuration

1	Cathode	Blue
2	Cathode	Green
3	Cathode	Red
4	Anode	Red
5	Anode	Green
6	Anode	Blue

Notes:

1. All Dimensions are in millimeters
2. Tolerance = ±0.2 mm unless otherwise specified
3. Terminal Finish: Ag plating
4. Encapsulation material: silicone resin

Table 1. Device Selection Guide

Part Number	Color 1 - AllInGaP Red			Color 2 - InGaN Green			Color 3 - InGaN Blue					
	Bin ID	Min. I _v @ 20mA (mcd)	Typ. I _v @ 20mA (mcd)	Max I _v @ 20mA (mcd)	Bin ID	Min. I _v @ 20mA (mcd)	Typ. I _v @ 20mA (mcd)	Max I _v @ 20mA (mcd)	Bin ID	Min. I _v @ 20mA (mcd)	Typ. I _v @ 20mA (mcd)	Max I _v @ 20mA (mcd)
ASMT-YTD2-0BB02	U2	560	745	1125	W1	1125	1600	2240	T1	285	380	560

Notes:

1. The luminous intensity I_v is measured at the mechanical axis of the LED package and it is tested in pulsing condition. The actual peak of the spatial radiation pattern may not be aligned with this axis.
2. Tolerance = ± 12%

Part Numbering System

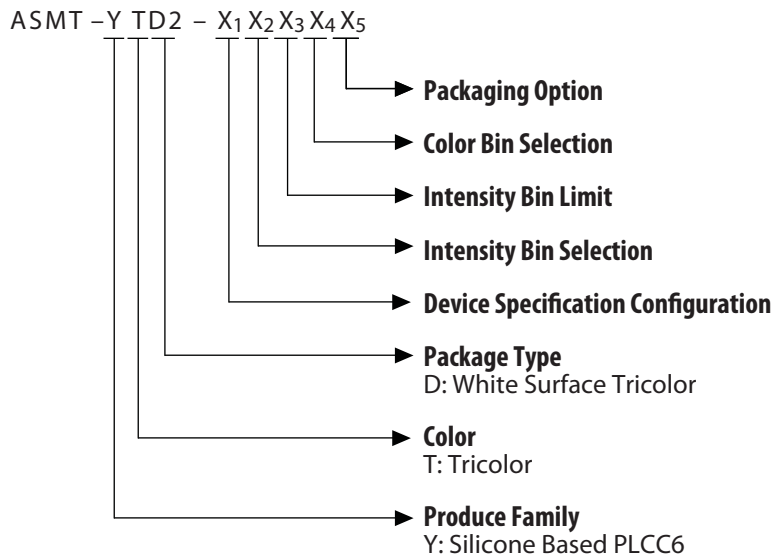

Table 2. Absolute Maximum Ratings ($T_A = 25^\circ\text{C}$)

Parameter	Red	Green & Blue	Unit
DC forward current ^[1]	50	30	mA
Peak forward current ^[2]	100	100	mA
Power dissipation	125	114	mW
Reverse voltage	4V ^[3]		V
Maximum junction temperature $T_{j\text{ max}}$	125		°C
Operating temperature range	-40 to + 110 ^[4]		°C
Storage temperature range	-40 to + 120		°C

Notes:

1. Derate linearly as shown in Figure 4a & 4b.
2. Duty Factor = 10% Frequency = 1KHz
3. Driving the LED in reverse bias condition is suitable for short term only
4. Refer to Figure 4a and figure 4b for more information

Table 3. Optical Characteristics ($T_A = 25^\circ\text{C}$)

Color	Dominant Wavelength, λ_d (nm) ^[1]			Peak Wavelength, λ_p (nm)	Viewing Angle $2\theta_{1/2}$ ^[2] (Degrees)	Luminous Efficacy η_V ^[3] (lm/W)	Luminous Efficiency η_e (lm/W)
	Min	Typ.	Max	Typ.	Typ.	Typ.	Typ.
Red	618	622	628	629	120	210	43
Green	525	530	537	521	120	535	75
Blue	465	470	477	464	120	84	15

Notes:

1. The dominant wavelength is derived from the CIE Chromaticity Diagram and represents the perceived color of the device.
2. $\theta_{1/2}$ is the off axis angle where the luminous intensity is $1/2$ the peak intensity
3. Radiant intensity, I_e in watts / steradian, may be calculated from the equation $I_e = I_V / \eta_V$, where I_V is the luminous intensity in candelas and η_V is the luminous efficacy in lumens / watt.
4. Φ_V is the total luminous flux output as measured with an integrating sphere at mono pulse condition.

Table 4. Electrical Characteristics ($T_A = 25^\circ\text{C}$)

Color	Forward Voltage, V_F (V) ^[1]			Reverse Voltage V_R @ 100 μA	Reverse Voltage V_R @ 10 μA	Thermal Resistance $R\theta_{J-P}$ ($^\circ\text{C}/\text{W}$) ^[2]
	Min	Typ.	Max.	Min.	Min.	Typ
Red	1.80	2.10	2.50	4	–	280
Green	2.80	3.20	3.80	–	4	180
Blue	2.80	3.20	3.80	–	4	180

Notes:

1. Tolerance $\pm 0.1\text{V}$.
2. One chip on thermal resistance

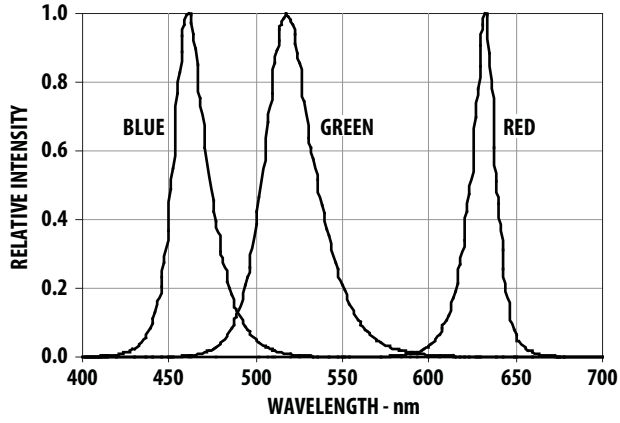

Figure 1. Relative Intensity vs Wavelength

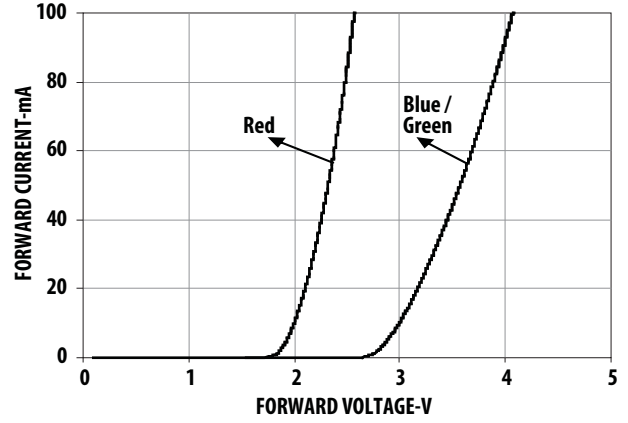

Figure 2. Forward Current-mA vs Forward Voltage-V

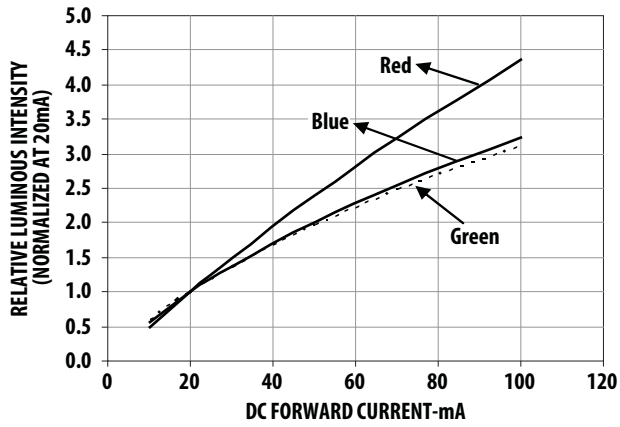

Figure 3. Relative Intensity vs Forward Current

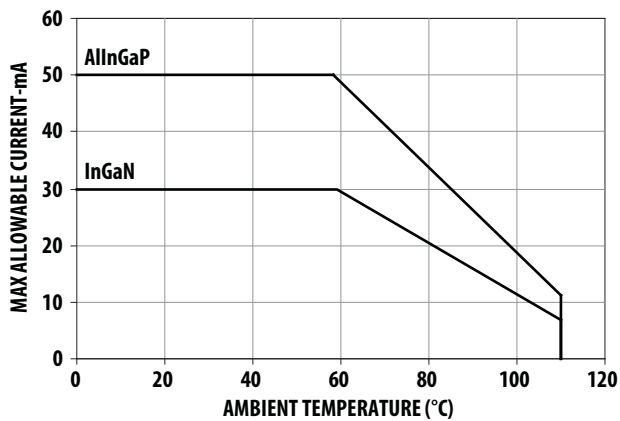

Figure 4a. Maximum forward current vs. ambient temperature. Derated based on $T_{JMAX} = 125^{\circ}C$. (3 chips)

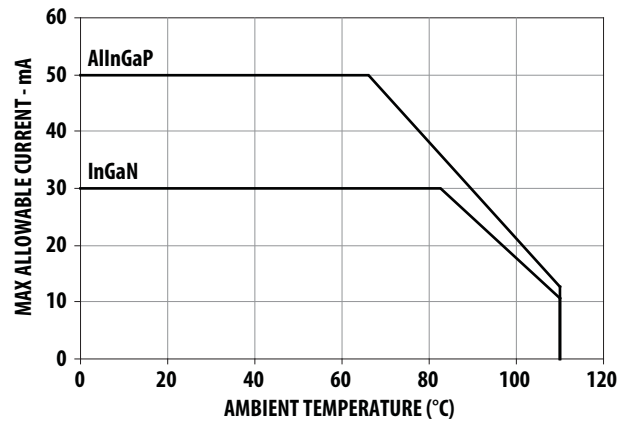

Figure 4b. Maximum forward current vs. ambient temperature. Derated based on $T_{JMAX} = 125^{\circ}C$. (single chip)

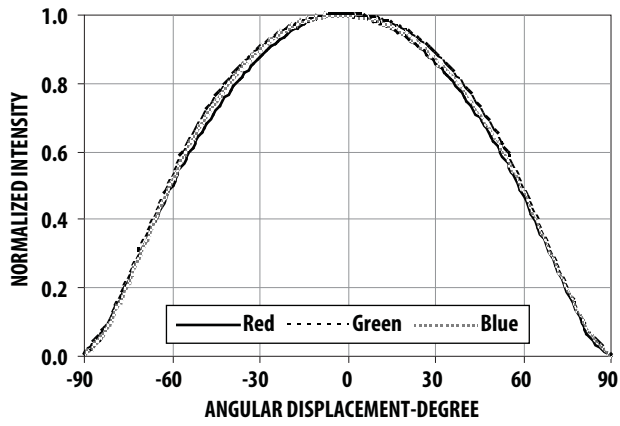

Figure 5a. Radiation Pattern for X axis

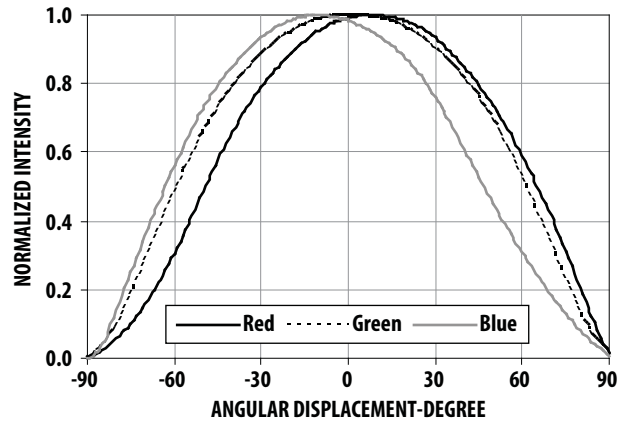

Figure 5b. Radiation Pattern for Y axis

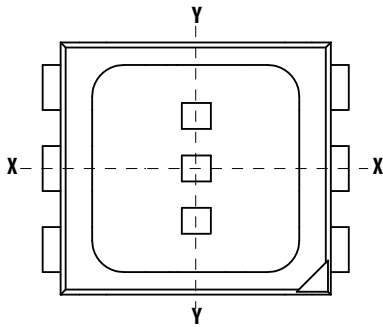

Figure 5c. Component Axis for Radiation Patterns

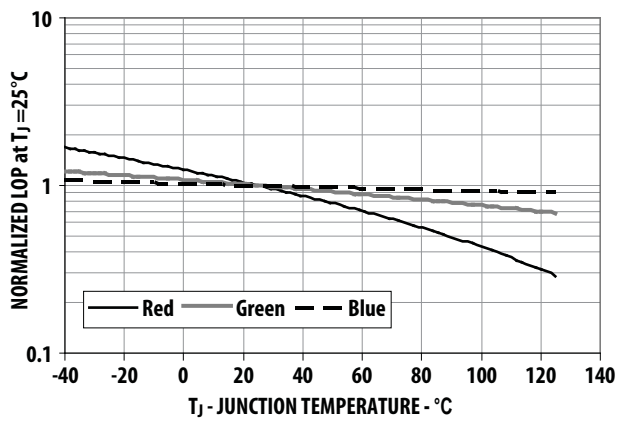

Figure 6. Relative Intensity vs Junction Temperature

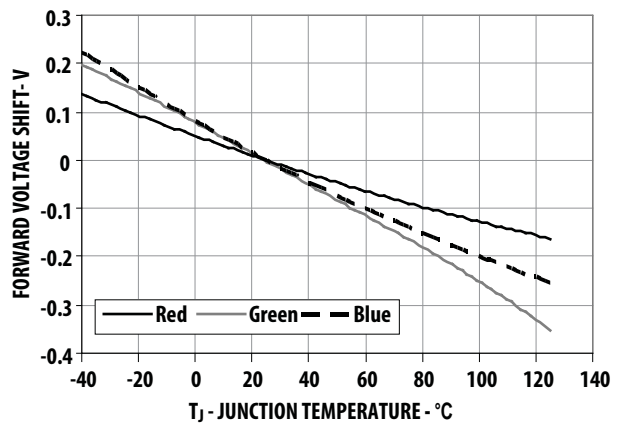

Figure 7. Forward Voltage vs Junction Temperature

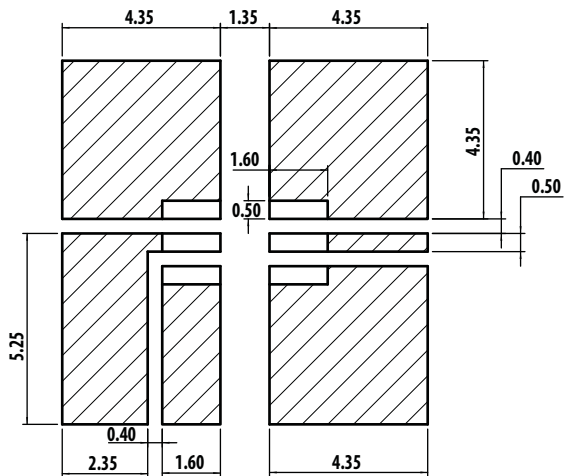

Figure 8a. Recommended soldering land pattern.

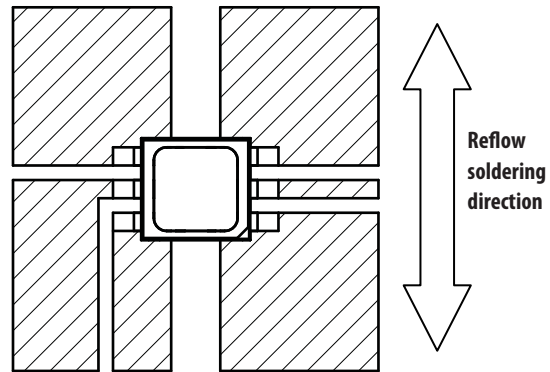
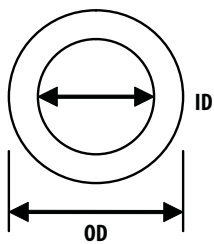

Figure 8b. LED Configuration on land pattern



ID = 1.7mm
OD = 3.5mm

Figure 9. Recommended Pick and Place Nozzle Tip

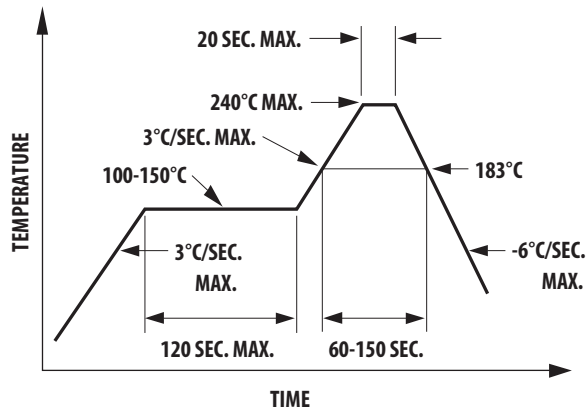

Figure 10. Recommended leaded reflow soldering profile.

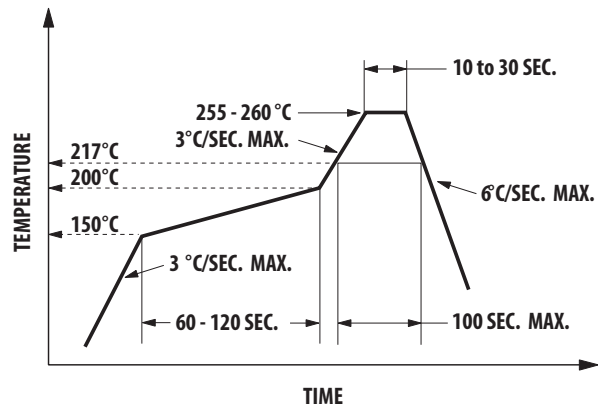

Figure 11. Recommended Pb-free reflow soldering profile.

Note: For detail information on reflow soldering of Avago surface mount LEDs, do refer to Avago Application Note AN 1060 Surface Mounting SMT LED Indicator Components

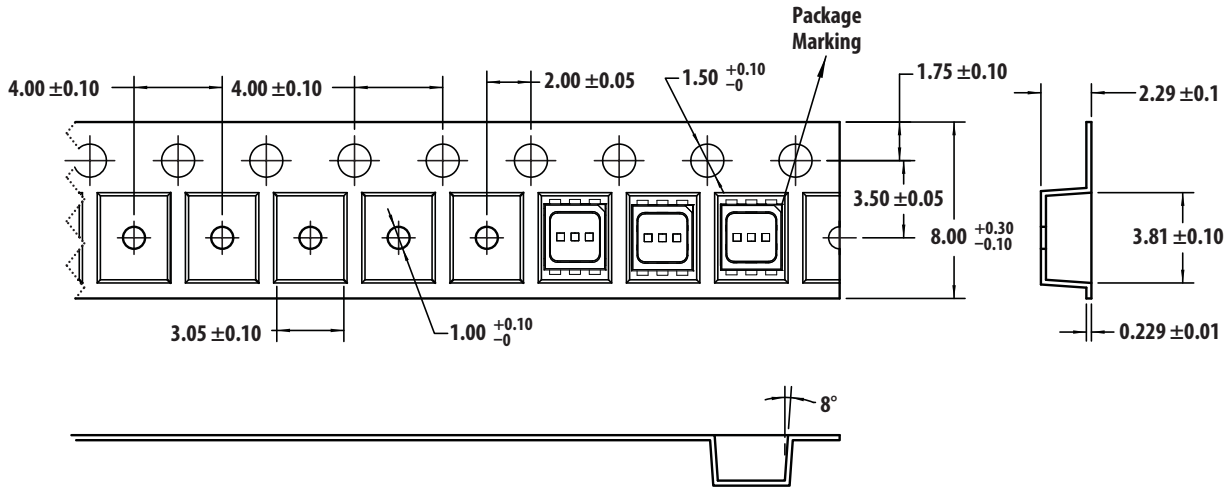

Figure 12. Carrier tape Dimension

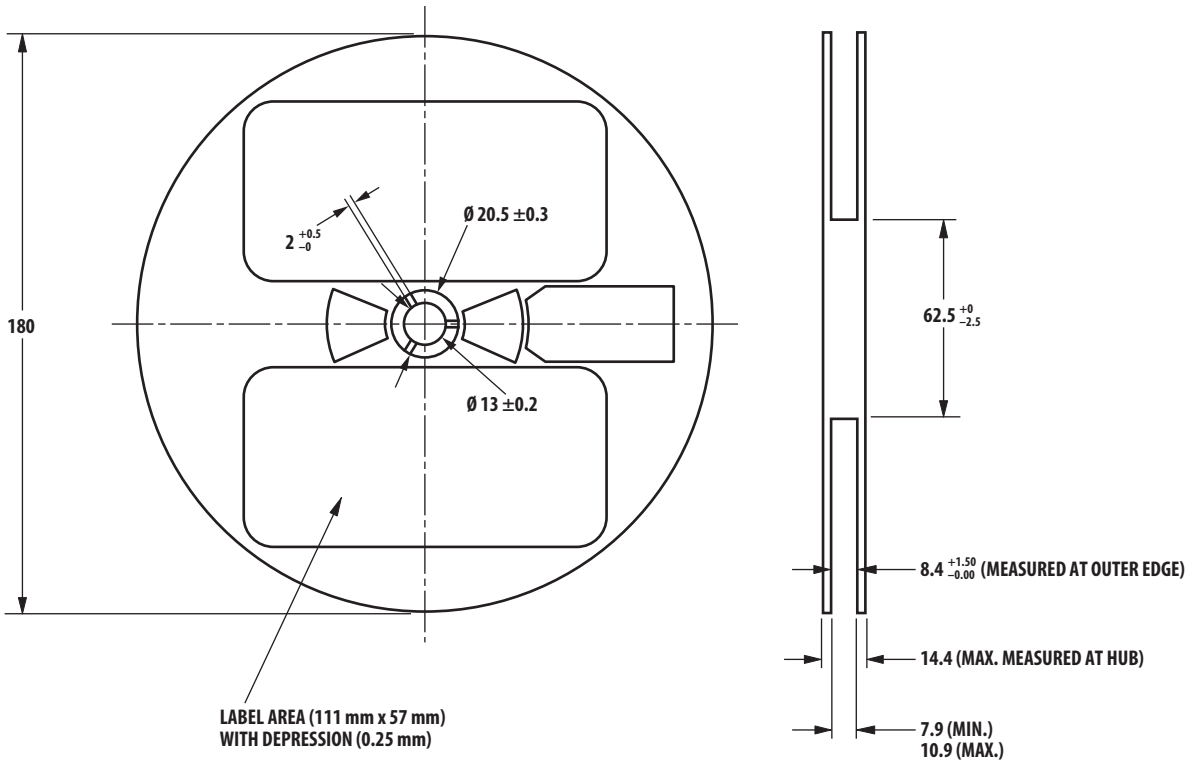

Figure 13. Reel Dimension

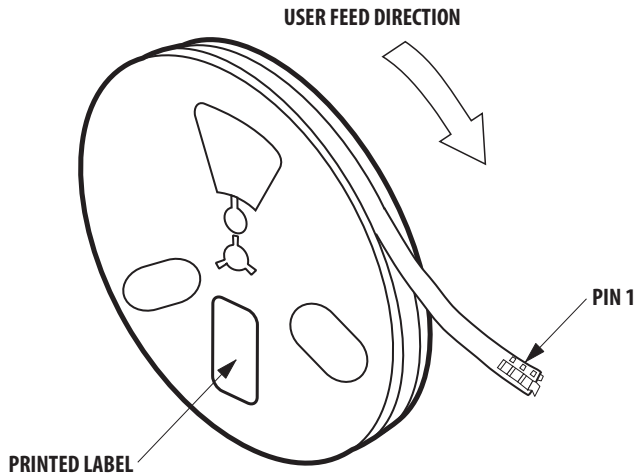

Figure 14. Reeling Orientation

Packaging Label:

(i) Avago Mother Label (Available on MBB bags)

(1P) Item: Part Number 	Avago TECHNOLOGIES STANDARD LABEL LS0002 RoHS Compliant Halogen Free e4 Max Temp 260C MSL2a
(1T) Lot: Lot Number 	(Q) QTY: Quantity
LPN: 	CAT: Intensity Bin
(9D)MFG Date: Manufacturing Date 	BIN: Color Bin
(P) Customer Item: 	
(V) Vendor ID: 	(9D) Date Code: Date Code
DeptID: 	Made In: Country of Origin

(1P) PART #: Part Number 	Avago TECHNOLOGIES BABY LABEL COSB001B V0.0
(1T) LOT #: Lot Number 	QUANTITY: Packing Quantity
(9D)MFG DATE: Manufacturing Date 	(9D): DATE CODE:
C/O: Country of Origin 	D/C: Date Code VF: CAT: INTENSITY BIN BIN: COLOR BIN
(1T) TAPE DATE: 	

Example indicates luminous Intensity information for Red, Green and Blue respectively from label:

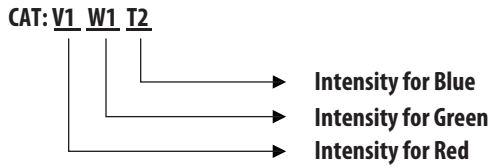

Example indicates color bin information for Green and Blue from label:

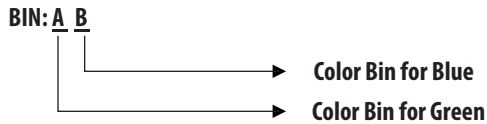

Note: There will be no red color bin information appear on label as it is not binned and support with full distribution range.

Intensity Bin Selection (X_2, X_3)

Individual reel will contain parts from 1 half bin only

Min Iv Bin (Minimum Intensity Bin)			
X_2	Red	Green	Blue
B	U2	W1	T1

Number of Half Bin from X_2			
X_3	Red	Green	Blue
B	3	3	3

Color Bin Selection (X_4)

Individual reel will contain parts from 1 full bin only

Color Bin Combinations			
X_4	Red	Green	Blue
0	Full distribution	A, B, C	A, B, C, D, E

Intensity Bin Limit

Bin ID	Min (mcd)	Max (mcd)
T1	285.0	355.0
T2	355.0	450.0
U1	450.0	560.0
U2	560.0	715.0
V1	705.0	900.0
V2	900.0	1125.0
W1	1125.0	1400.0
W2	1400.0	1800.0
X1	1800.0	2240.0

Tolerance for each bin limits is $\pm 12\%$

Color Bin Limits

Red Color Bin Table

Bin ID	Min Dom	Max Dom					
Full	618	628	x	0.6873	0.6696	0.6866	0.7052
Distribution			y	0.3126	0.3136	0.2967	0.2948

Tolerance of each bin limit is ± 1 nm

Green Color Bin Table

Bin ID	Min Dom	Max Dom					
A	525.0	531.0	x	0.1142	0.1799	0.2138	0.1625
			y	0.8262	0.6783	0.6609	0.8012
B	528.0	534.0	x	0.1387	0.1971	0.2298	0.1854
			y	0.8148	0.6703	0.6507	0.7867
C	531.0	537.0	x	0.1625	0.2138	0.2454	0.2077
			y	0.8012	0.6609	0.6397	0.7711

Tolerance of each bin limit is ± 1 nm

Blue Color Bin Table

Bin ID	Min Dom	Max Dom	Corner				
			Point	1	2	3	4
A	465.0	469.0	x	0.1355	0.1751	0.168	0.127
			y	0.0399	0.0986	0.1094	0.053
B	467.0	471.0	x	0.1314	0.1718	0.1638	0.122
			y	0.0459	0.1034	0.1167	0.063
C	469.0	473.0	x	0.1267	0.168	0.1593	0.116
			y	0.0534	0.1094	0.1255	0.074
D	471.0	475.0	x	0.1215	0.1638	0.1543	0.1096
			y	0.0626	0.1167	0.1361	0.0868
E	473.0	477.0	x	0.1158	0.1593	0.1489	0.1028
			y	0.0736	0.1255	0.1490	0.1029

Tolerance of each bin limit is ± 1 nm

Packaging Option (X₅)

Option	Test Current	Reel Size
2	20mA	7 inch

Handling Precaution

The encapsulation material of the LED is made of silicone for better product reliability. Since silicone is a soft material, avoid pressing on the silicon or poking the silicon with a sharp object as the product could be damaged and cause premature failure. During assembly handling, the unit should be held by the body only. Please refer to Avago Application Note AN 5288 for additional handling information and proper procedures.

Moisture Sensitivity

This product has a Moisture Sensitive Level 2a rating per JEDEC J-STD-020. Refer to Avago Application Note AN5305, *Handling of Moisture Sensitive Surface Mount Devices*, for additional details and a review of proper handling procedures.

A. Storage before use

- An Unopened moisture barrier bag (MBB) can be stored at <40°C/90%RH for 12 months. If the actual shelf life has exceeded 12 months and the humidity Indicator Card (HIC) indicates that baking is not required, then it is safe to reflow the LEDs per the original MSL rating.
- It is recommended that the MBB not be opened prior to assembly (e.g. for IQC).

B. Control after opening the MBB

- The humidity indicator card (HIC) shall be read immediately upon opening of MBB.
- The LEDs must be kept at <30°C/60%RH at all times and all high temperature related processes including soldering, curing or rework need to be completed within 672 hours.

C. Control for unfinished reel

- Unused LEDs must be stored in a sealed MBB with desiccant or desiccator at <5%RH.

D. Control of assembled boards

- If the PCB soldered with the LEDs is to be subjected to other high temperature processes, the PCB need to be stored in sealed MBB with desiccant or desiccator at <5%RH to ensure that all LEDs have not exceeded their floor life of 672 hours.

E. Baking is required if:

- The HIC indicator is not BROWN at 10% and is AZURE at 5%.
- The LEDs are exposed to condition of >30°C/60% RH at any time.
- The Led floor life exceeded 672hrs.

The recommended baking condition is: 60±5°C for 20hrs

DISCLAIMER: Avago's products and software are not specifically designed, manufactured or authorized for sale as parts, components or assemblies for the planning, construction, maintenance or direct operation of a nuclear facility or for use in medical devices or applications. Customer is solely responsible, and waives all rights to make claims against avago or its suppliers, for all loss, damage, expense or liability in connection with such use.

For product information and a complete list of distributors, please go to our web site: www.avagotech.com



Компания «ЭлектроПласт» предлагает заключение долгосрочных отношений при поставках импортных электронных компонентов на взаимовыгодных условиях!

Наши преимущества:

- Оперативные поставки широкого спектра электронных компонентов отечественного и импортного производства напрямую от производителей и с крупнейших мировых складов;
- Поставка более 17-ти миллионов наименований электронных компонентов;
- Поставка сложных, дефицитных, либо снятых с производства позиций;
- Оперативные сроки поставки под заказ (от 5 рабочих дней);
- Экспресс доставка в любую точку России;
- Техническая поддержка проекта, помощь в подборе аналогов, поставка прототипов;
- Система менеджмента качества сертифицирована по Международному стандарту ISO 9001;
- Лицензия ФСБ на осуществление работ с использованием сведений, составляющих государственную тайну;
- Поставка специализированных компонентов (Xilinx, Altera, Analog Devices, Intersil, Interpoint, Microsemi, Aeroflex, Peregrine, Syfer, Eurofarad, Texas Instrument, Miteq, Cobham, E2V, MA-COM, Hittite, Mini-Circuits, General Dynamics и др.);

Помимо этого, одним из направлений компании «ЭлектроПласт» является направление «Источники питания». Мы предлагаем Вам помощь Конструкторского отдела:

- Подбор оптимального решения, техническое обоснование при выборе компонента;
- Подбор аналогов;
- Консультации по применению компонента;
- Поставка образцов и прототипов;
- Техническая поддержка проекта;
- Защита от снятия компонента с производства.



Как с нами связаться

Телефон: 8 (812) 309 58 32 (многоканальный)

Факс: 8 (812) 320-02-42

Электронная почта: org@eplast1.ru

Адрес: 198099, г. Санкт-Петербург, ул. Калинина, дом 2, корпус 4, литера А.