

FEATURES

- Step-Up/Step-Down Fractional Charge Pump for Up to 92% Efficiency
- Independent Current and Dimming Control for 1-4 LED Main, 1-2 LED Sub and RGB LED Displays
- LED Currents Programmable Using 3-Wire Serial Interface
- Up to 250mA of Continuous LED Current
- 0.7% LED Current Matching
- Low Noise Constant Frequency Operation*
- Minimal Component Count
- Automatic Soft-Start Limits Inrush Current
- Four Programmable Dimming States for Main and Sub Displays
- Up to 4096 Color Combinations for RGB Display
- Low Shutdown Current: $I_{CC} < 1\mu A$
- Tiny 24-Lead (4mm × 4mm) QFN Package

APPLICATIONS

- Cellular Phones
- Wireless PDAs
- Multidisplay Handheld Devices

LT, LTC and LT are registered trademarks of Linear Technology Corporation.
 * U.S. Patent 6,411,531

DESCRIPTION

The LTC[®]3205 is a highly integrated multidisplay LED controller. The part contains a high efficiency, low noise fractional step-up/step-down charge pump to provide power for both main and sub white LED displays plus an RGB color LED display. The LTC3205 requires only four small ceramic capacitors plus two resistors to form a complete 3-display LED power supply and current controller.

Maximum currents for the main/sub and RGB displays are set independently with a single resistor. Current for each LED is controlled with an internal current source. Dimming and ON/OFF control for all displays are achieved via a 3-wire serial interface. Four dimming states exist for the main and sub displays and 16 dimming states are available via internal PWM for the red, green and blue LEDs resulting in up to 4096 color combinations.

The LTC3205 charge pump optimizes efficiency based on V_{IN} and LED forward voltage conditions. The part powers up in step-down mode and automatically switches to step-up mode once any enabled LED current source begins to enter dropout. Internal circuitry prevents inrush current and excess input noise during start-up and mode switching.

The LTC3205 is available in a low profile 24-lead (4mm × 4mm × 0.8mm) QFN package.

TYPICAL APPLICATION

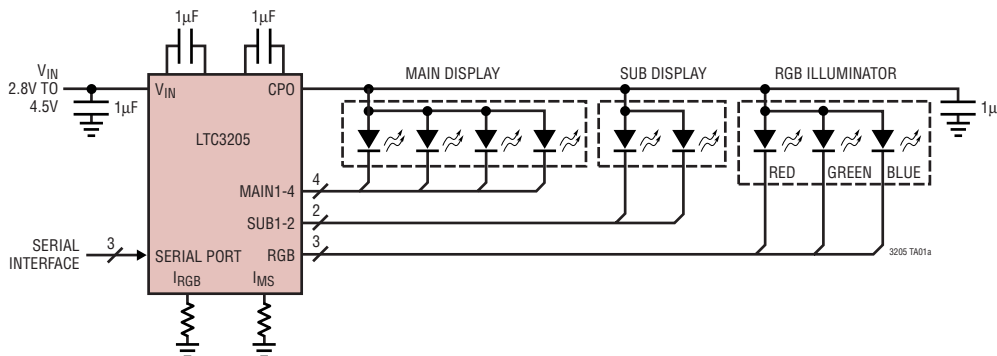

4-LED Main Panel Efficiency vs Input Voltage

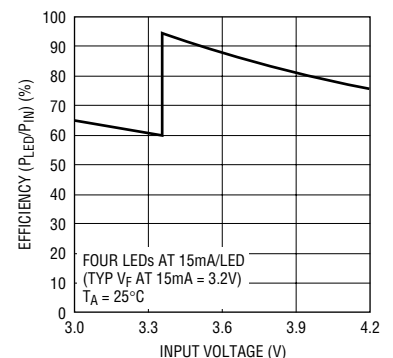

ABSOLUTE MAXIMUM RATINGS

(Note 1)

V_{IN} , DV_{CC} , CPO to GND	-0.3V TO 6V
D_{IN} , SCLK, LD, STEPUP, ENRGB	-0.3V to (DV_{CC} + 0.3V)
I_{CPO} (Note 4)	250mA
$I_{MAIN1-4}$, $I_{SUB1,2}$ (Note 4)	50mA
$I_{RED, GREEN, BLUE}$ (Note 4)	100mA
I_{MS} , I_{RGB} (Note 4)	1mA
CPO Short-Circuit Duration	Indefinite
Operating Temperature Range (Note 2) ..	-40°C to 85°C
Storage Temperature Range	-65°C to 125°C

PACKAGE/ORDER INFORMATION

<p>TOP VIEW</p> <p>24-LEAD (4mm x 4mm) PLASTIC QFN</p> <p>$T_{JMAX} = 150^{\circ}C$, $\theta_{JA} = 37^{\circ}C/W$, $\theta_{JC} = 2^{\circ}C/W$</p> <p>EXPOSED PAD IS PGND (PIN 25)</p> <p>MUST BE SOLDERED TO PCB</p>	ORDER PART NUMBER
	LTC3205EUF
	UF PART MARKING
	3205

Consult LTC Marketing for parts specified with wider operating temperature ranges.

ELECTRICAL CHARACTERISTICS

The ● denotes the specifications which apply over the full operating temperature range, otherwise specifications are at $T_A = 25^{\circ}C$. $V_{IN} = 3.6V$, $DV_{CC} = 1.8V$ unless otherwise noted.

SYMBOL	PARAMETER	CONDITIONS	MIN	TYP	MAX	UNITS
Input Power Supply						
	V_{IN} Operating Voltage		● 2.8		4.5	V
	DV_{CC} Operating Voltage		● 1.5		5.5	V
	I_{VIN} Operating Current	I_{CPO} , I_{MS} , $I_{IRGB} = 0\mu A$, Step-Down Mode $I_{CPO} = 0\mu A$, Step-Up Mode		70 4.2		μA mA
	I_{DVCC} Operating Current	Serial Port Idle			1	μA
	V_{IN} Shutdown Current				1	μA
	DV_{CC} Shutdown Current				1	μA
White LED Current (MAIN1-MAIN4, SUB1, SUB2)						
	I_{MS} Servo Voltage	$25\mu A < I_{MS} < 75\mu A$	● 1.193 1.175	1.223 1.223	1.253 1.271	V V
	Full-Scale LED Current Ratio (I_{LED}/I_{MS})	MAIN1-MAIN4, SUB1, SUB2 Voltage = 1V	● 368	400	432	mA/mA
	Half-Scale LED Current Ratio (I_{LED}/I_{MS})	MAIN1-MAIN4, SUB1, SUB2 Voltage = 1V	● 184	200	216	mA/mA
	Quarter-Scale LED Current Ratio (I_{LED}/I_{MS})	MAIN1-MAIN4, SUB1, SUB2 Voltage = 1V	● 92	100	108	mA/mA
	LED Current Matching	Any Two MAIN or SUB Outputs		0.7		%
RGB LED Current (RED, GREEN, BLUE)						
	I_{RGB} Servo Voltage	$25\mu A < I_{RGB} < 75\mu A$	● 1.193 1.175	1.223 1.223	1.253 1.271	V V
	LED Current Ratio (I_{LED}/I_{RGB})	RED, GREEN, BLUE Voltage = 1V	360	400	440	mA/mA
RGB PWM Frequency						
	RGB LED Switching Frequency			3.5		kHz
	RGB PWM (Duty Factor) Range		0/15		15/15	%

ELECTRICAL CHARACTERISTICS

The ● denotes the specifications which apply over the full operating temperature range, otherwise specifications are at $T_A = 25^\circ\text{C}$. $V_{IN} = 3.6\text{V}$, $DV_{CC} = 1.8\text{V}$ unless otherwise noted.

SYMBOL	PARAMETER	CONDITIONS	MIN	TYP	MAX	UNITS
Charge Pump (CPO)						
	1:1 Mode Output Impedance			0.8		Ω
	2:3 Mode Output Impedance	$V_{IN} = 3\text{V}$, $V_{CPO} = 4.2\text{V}$ (Note 3)		2.5		Ω
	CPO Regulation Voltage	$I_{CPO} = 20\text{mA}$, 2:3 Mode		4.7		V
	CLK Frequency		0.6	0.8	1.1	MHz
D_{IN}, SCLK, \overline{LD}, STEPUP, ENRGB						
V_{IL}	Low Level Input Voltage		●	$0.15 \cdot DV_{CC}$		V
V_{IH}	High Level Input Voltage		●	$0.85 \cdot DV_{CC}$		V
I_{IH}	Input Current	D_{IN} , SCLK, \overline{LD} , STEPUP, ENRGB = DV_{CC}	●	-1	1	μA
I_{IL}	Input Current	D_{IN} , SCLK, \overline{LD} , STEPUP, ENRGB = 0V	●	-1	1	μA
Serial Port Timing						
t_{DS}	D_{IN} Valid to SCLK Setup			35		ns
t_{DH}	D_{IN} Valid to SCLK Hold			35		ns
t_L	SCLK Low Time			35		ns
t_H	SCLK High Time			35		ns
t_{LW}	\overline{LD} Pulse Width			35		ns
t_{CL}	SCLK to \overline{LD}			35		ns
t_{LC}	\overline{LD} to SCLK			0		ns

Note 1: Absolute Maximum Ratings are those values beyond which the life of a device may be impaired.

Note 2: The LTC3205E is guaranteed to meet performance specifications from 0°C to 70°C . Specifications over the -40°C to 85°C operating temperature range are assured by design, characterization and correlation with statistical process controls.

Note 3: 2:3 mode output impedance is defined as $(1.5V_{IN} - V_{CPO})/I_{CPO}$.

Note 4: Based on long term current density limitations.

TYPICAL PERFORMANCE CHARACTERISTICS

LED Pin Sink Current vs LED Pin Voltage

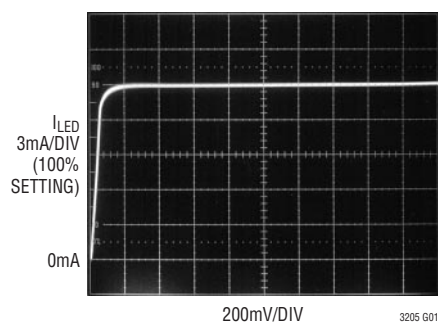

Input and Output Charge Pump Noise

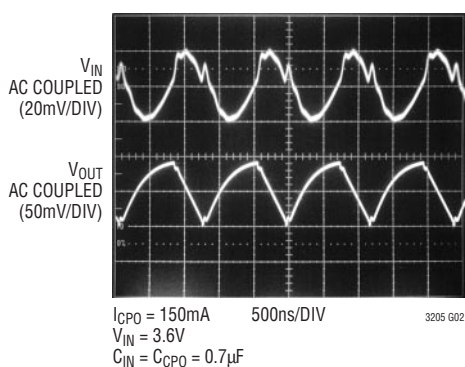

4-LED Main Panel Efficiency vs Input Voltage

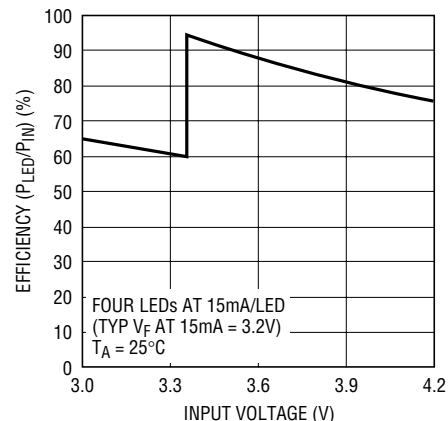

TYPICAL PERFORMANCE CHARACTERISTICS

1:1 Mode Switch Resistance vs Temperature

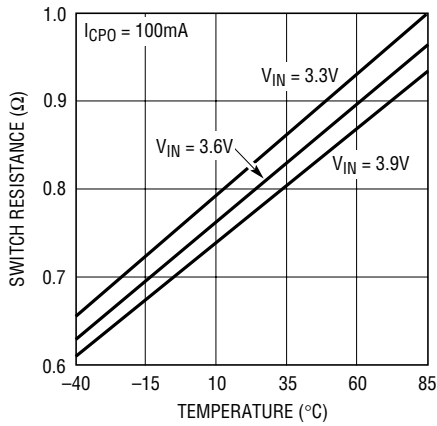

2:3 Mode Charge Pump Open-Loop Output Resistance vs Temperature ($3/2V_{\text{IN}} - V_{\text{CPO}}$)/ I_{CPO}

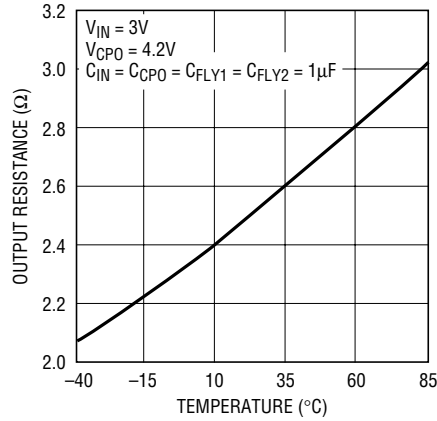

2:3 Mode CPO Voltage vs Load Current

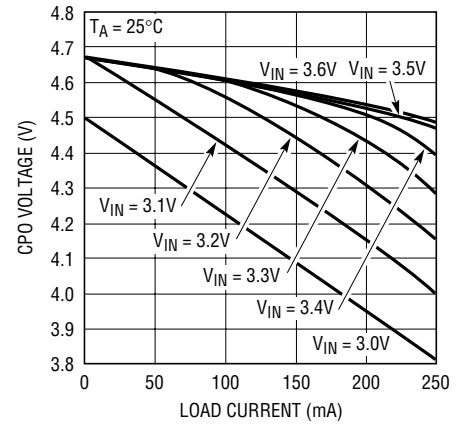

2:3 Mode CPO Voltage in Current Limit

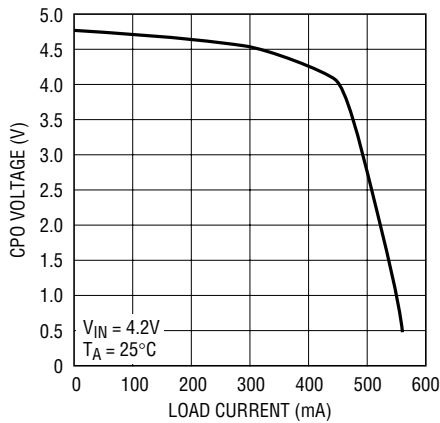

Oscillator Frequency vs VIN Voltage

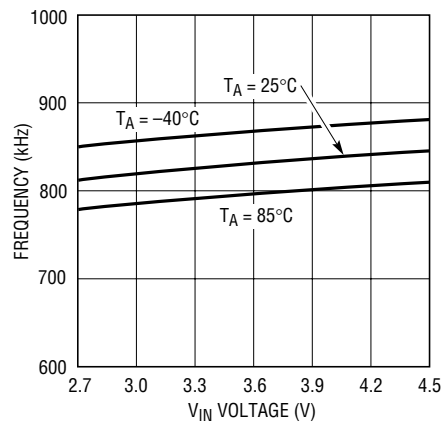

DVCC Shutdown Current vs DVCC

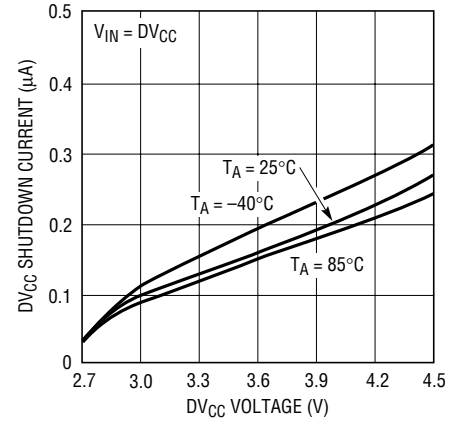

VIN Shutdown Current vs Input Voltage

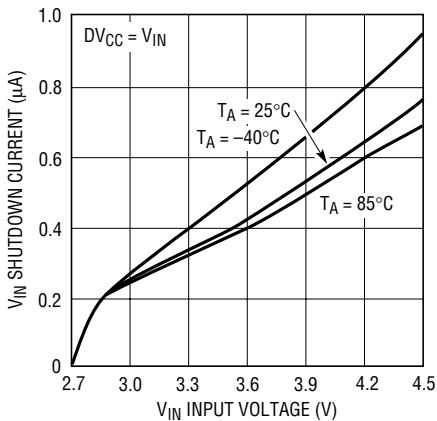

1:1 Mode No Load Supply Current vs VIN

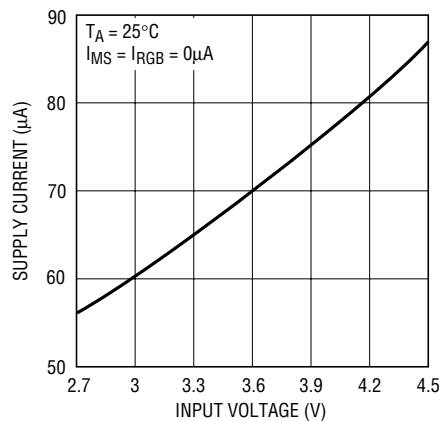

2:3 Mode Supply Current vs ICPO ($I_{\text{IN}} - 3/2I_{\text{CPO}}$)

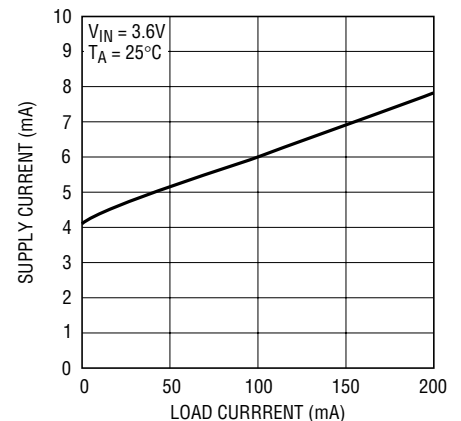

TYPICAL PERFORMANCE CHARACTERISTICS

Input Supply Voltage Required for Higher LED Currents

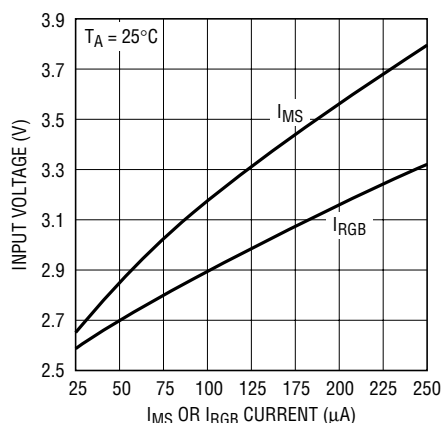

3205 G14

Compliance Voltage for Higher LED Currents

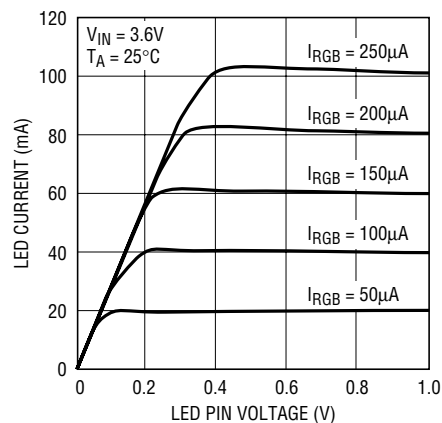

3205 G15

RGB LED Turn On and Off Characteristics

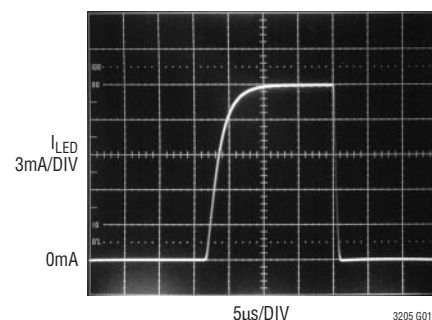

3205 G011

PIN FUNCTIONS

MAIN1-MAIN4 (Pins 2, 1, 24, 23): Current Source Outputs for the Main Display White LEDs. The current for the main display is controlled by the resistor on the I_{MS} pin. The LEDs on the main display can be set to 100%, 50%, 25% or 0% of full-scale programmed current under software control. See Tables 1 and 2.

C1+, C1-, C2+, C2- (Pins 5, 4, 6, 3): Charge Pump Flying Capacitor Pins. A $1\mu F$ X7R or X5R ceramic capacitor should be connected from C1+ to C1- and another from C2+ to C2-.

D_{IN} (Pin 7): Input Data for the 16-Bit Serial Port. Serial data is shifted in one bit per clock to control the LTC3205 (see Table 1). The logic level for D_{IN} is referenced to DV_{CC}.

SCLK (Pin 8): Clock Input for the 16-Bit Serial Port (see Figure 3). The logic level for SCLK is referenced to DV_{CC}.

LD (Pin 9): Load Input for the 16-Bit Serial Port. Command data is loaded into the command latch on the falling edge of LD (see Figure 3). The logic level for LD is referenced to DV_{CC}.

ENRGB (Pin 10): This pin is used to enable and disable the red, green and blue current sources. Once ENRGB is brought high, the LTC3205 illuminates the RGB display with the color combination that was previously programmed via the serial port. When the main and sub displays are off and ENRGB is low, the LTC3205 will be in shutdown. The logic level for ENRGB is referenced to DV_{CC}.

STEPUP (Pin 11): A logic high on this pin forces the LTC3205's charge pump to operate in 2:3 step-up mode, thereby eliminating any possibility of the device switching from 1:1 mode to 2:3 mode during critical communication periods. The logic level for STEPUP is referenced to DV_{CC}.

DV_{CC} (Pin 12): This pin sets the logic reference level of the LTC3205.

I_{RGB} (Pin 13): This pin controls the amount of LED current at the RED, GREEN and BLUE LED pins. The I_{RGB} pin serves to 1.223V when there is a resistor to ground. The current in the RED, GREEN and BLUE LEDs will be 400 times the current at the I_{RGB} pin when programmed to full scale (see Tables 1 and 3).

I_{MS} (Pin 14): This pin controls the maximum amount of LED current in both the main and sub LED displays. The I_{MS} pin serves to 1.223V when there is a resistor to ground. The currents in the main and sub display LEDs will be 100, 200 or 400 times the current at the I_{MS} pin depending on which setting is chosen from the serial port.

CPO (Pin 15): Output of the Charge Pump. This output should be used to power white, blue and "true" green LEDs. Red LEDs can be powered from V_{IN} or CPO. An X5R or X7R low impedance (ceramic) $1\mu F$ charge storage capacitor is required on CPO.

PIN FUNCTIONS

V_{IN} (Pin 16): Supply Voltage for the Charge Pump. The V_{IN} pin should be connected directly to the battery and bypassed with a 1μF X5R or X7R ceramic capacitor.

SGND (Pin 17): Ground for the Control Logic. This pin should be connected directly to a low impedance ground plane.

RED, GREEN, BLUE (Pins 18, 19, 20): Current Source Outputs for the RGB Illuminator LEDs. The currents for the RGB LEDs are controlled by the resistor on the I_{RGB} pin. The RGB LEDs can independently be set to any duty cycle from 0/15 through 15/15 under software control giving a total of 16 shades per LED and a total of 4096

colors for the illuminator. See Tables 1 and 3. The RGB LEDs are modulated at 1/240 the speed of the charge pump oscillator.

SUB1, SUB2 (Pins 22, 21): Current Source Outputs for the Sub Display White LEDs. The current for the sub display is controlled by the resistor on the I_{MS} pin. The LEDs on the sub display can be set to 100%, 50%, 25% or 0% of full scale under software control. See Tables 1 and 2.

PGND (Pin 25, Exposed Pad): Power Ground for the Charge Pump. The exposed pad should be connected directly to a low impedance ground plane.

BLOCK DIAGRAM

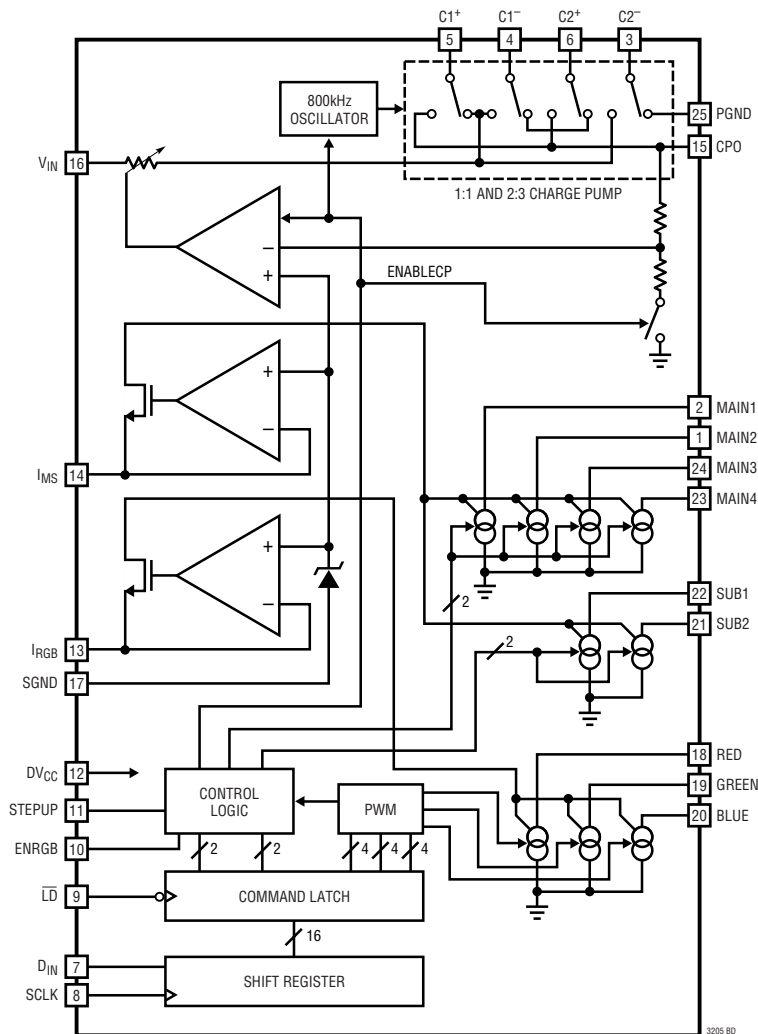

OPERATION

Power Management

To optimize efficiency, the power management section of the LTC3205 provides two methods of supplying power to the CPO pin: 1:1 direct connect mode or 2:3 boost mode. When either the main or sub displays of the LTC3205 are enabled, the power management system connects the CPO pin directly to V_{IN} with a low impedance switch. If the voltage supplied at V_{IN} is high enough to power all of the LEDs with the programmed current, the system will remain in this “direct connect” mode providing maximum efficiency. Internal circuits monitor all MAIN and SUB current sources for the onset of “dropout,” the point at which the current sources can no longer supply programmed current. As the battery voltage falls, the LED with the largest forward voltage will reach the “drop out” threshold first. When any of the four main or two sub display LEDs reach the dropout threshold, the LTC3205 will switch to boost mode and automatically soft-start the 2:3 boost charge pump. The constant frequency charge pump is designed to minimize the amount of noise generated at the V_{IN} supply.

The 2:3 step-up charge pump uses a patented constant frequency architecture to combine the best efficiency with the maximum available power at the lowest noise level.

If the red, green or blue LEDs are programmed to be on at any duty cycle, the charge pump runs continuously.

Soft-Start

To prevent excessive inrush current and supply droop when switching into step-up mode, the LTC3205 employs a soft-start feature on its charge pump. The current available to the CPO pin is increased linearly over a period of 1.2ms.

Charge Pump Strength

When the LTC3205 operates in 2:3 boost mode, the charge pump can be modeled as a Thevenin-equivalent circuit to determine the amount of current available from the effective input voltage, $1.5V_{IN}$ and the effective open-loop output resistance, R_{OL} (Figure 1).

R_{OL} is dependent on a number of factors including the switching term, $1/(2f_{OSC} \cdot C_{FLY})$, internal switch resistances and the nonoverlap period of the switching circuit.

However, for a given R_{OL} , the amount of current available will be directly proportional to the advantage voltage $1.5V_{IN} - V_{CPO}$. Consider the example of driving white LEDs from a 3.1V supply. If the LED forward voltage is 3.8V and the current sources require 100mV, the advantage voltage is $3.1V \cdot 1.5V - 3.8V - 0.1V$ or 750mV. Notice that if the input voltage is raised to 3.2V, the advantage voltage jumps to 900mV—a 20% improvement in available strength.

From Figure 1, the available current is given by:

$$I_{OUT} = \frac{1.5V_{IN} - V_{CPO}}{R_{OL}}$$

Typical values of R_{OL} as a function of temperature are shown in Figure 2.

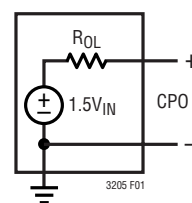

Figure 1. Equivalent Open-Loop Circuit

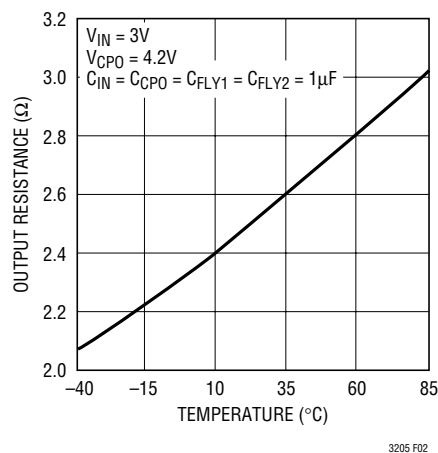

Figure 2. Typical R_{OL} vs Temperature

Zero Shutdown Current

Although the LTC3205 is designed to have very low shutdown current, it will draw about 400nA on V_{IN} when in shutdown. For applications that require zero shutdown current, the DV_{CC} pin can be grounded. This will reduce the V_{IN} current to very near zero. Internal logic ensures that the

OPERATION

LTC3205 is in shutdown when DV_{CC} is grounded. Note, however, that all of the logic signals that are referenced to DV_{CC} (D_{IN}, SCLK, $\overline{\text{LD}}$, ENRGB and STEPUP) will need to be at DV_{CC} or below (i.e., ground) to keep from violating the absolute maximum specifications on these pins.

Serial Port

The microcontroller compatible serial port provides all of the command and control inputs for the LTC3205. Data on the D_{IN} input is loaded on the rising edge of SCLK. D15 is loaded first and D0 last. Once all bits have been clocked into the shift register, the command data is loaded into the command register by bringing $\overline{\text{LD}}$ low. At this time, the command register is latched and the LTC3205 will begin to act upon the new command set. The serial port uses static logic registers so there is no minimum speed at which it can be operated. Figure 3 shows the operation of the serial port.

Table 1 shows the mapping of the serial port bits to the operation of the various displays. Bits D15 and D14 control the brightness of the four LEDs in the main display. Bits D13 and D12 control the brightness of the two LEDs in the sub display. The red, green and blue LEDs each have four bits assigned giving a linear range of 16 brightness levels to each of the LEDs.

Programming the MAIN and SUB LED Currents

Table 2 indicates the decoding of the Main and Sub display control bits.

The current levels of both the main and sub displays are controlled by precisely mirroring a multiple of the current at the I_{MS} pin.

The main and sub display LED currents will follow the relationship:

$$I_{\text{MAIN/SUB}} = N \frac{1.223\text{V}}{R_{\text{MAIN/SUB}}}$$

where N is equal to 400, 200, 100 or 0 depending on which current setting is selected. R_{MAIN/SUB} is the value of the resistor on the I_{MS} pin. The scale factors are spaced pseudo exponentially to compensate for the vision perception of the human eye (zero is a special case needed for shutdown).

The LTC3205 can power up to six white LEDs (four for the main display, two for the sub display), however, it is not necessary to have all six in each application. Any of the four main or two sub LED outputs can be disabled by connecting the unused output to CPO.

Table 2. Main and Sub Display Current Levels

D15 D13	D14 D12	FRACTION OF FULL-SCALE CURRENT (%)
0	0	0
0	1	25
1	0	50
1	1	100

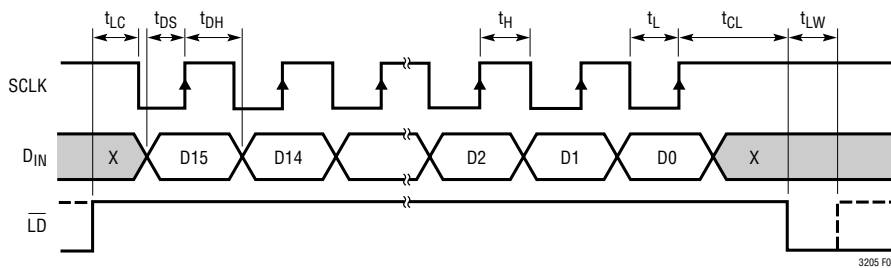

Figure 3. Serial Port Timing Diagram

Table 1. Serial Port Mapping

D15	D14	D13	D12	D11	D10	D9	D8	D7	D6	D5	D4	D3	D2	D1	D0
MAIN1- MAIN4 Current Level (Table 2)		SUB1- SUB2 Current Level (Table 2)		Blue LED Duty Cycle (Table 3)				Green LED Duty Cycle (Table 3)				Red LED Duty Cycle (Table 3)			

OPERATION

Unused MAIN or SUB Display LED Pins

Any of the six white LED pins (MAIN1-MAIN4, SUB1 and SUB2) can cause the LTC3205 to switch from 1:1 mode to 2:3 charge pump mode if they drop out. If an unused LED pin is left unconnected or grounded, it will automatically drop out and force the LTC3205 into charge pump mode. To avoid this problem, unused LED pins on the MAIN and SUB displays should be connected to CPO. However, power is not wasted in this configuration. When the LED pin voltage is within approximately 1V of CPO, its LED current is switched off and only a small 10µA test current remains. Figure 4 shows a block diagram of each of the MAIN and SUB LED pins. The RED, GREEN and BLUE pins do not affect the state of the charge pump so they can be left floating or grounded if unused.

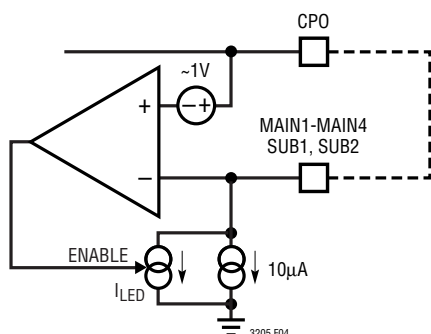

Figure 4. Internal MAIN and SUB Panel LED Disable Circuit

RGB Illuminator Drivers

The red, green and blue LEDs can be individually set to have a duty cycle ranging from 0/15 (off) to 15/15 (full on) with 1/15 increments in between. The combination of 16 possible brightness levels gives the RGB indicator LED a

Table 3. RGB Duty Cycles

D11 D7 D3	D10 D6 D2	D9 D5 D1	D8 D4 D0	HEX CODE	DUTY CYCLE (%)
0	0	0	0	0	0/15
0	0	0	1	1	1/15
0	0	1	0	2	2/15
0	0	1	1	3	3/15
0	1	0	0	4	4/15
0	1	0	1	5	5/15
0	1	1	0	6	6/15
0	1	1	1	7	7/15
1	0	0	0	8	8/15
1	0	0	1	9	9/15
1	0	1	0	A	10/15
1	0	1	1	B	11/15
1	1	0	0	C	12/15
1	1	0	1	D	13/15
1	1	1	0	E	14/15
1	1	1	1	F	15/15

total of 4096 colors. Table 3 indicates the decoding of the red, green and blue LEDs.

The full-scale currents in the red, green and blue LEDs are controlled by the current at the I_{RGB} pin in a similar manner to those in the main and sub panels. The I_{RGB} pin is regulated at 1.223V and the LED current is a precise multiple of the I_{RGB} current.

The RGB display LED currents will follow the relationship:

$$I_{RED, GREEN, BLUE} = 400 \frac{1.223V}{R_{RGB}}$$

where R_{RGB} is the value of the resistor on the I_{RGB} pin.

APPLICATIONS INFORMATION

Interfacing to a Microcontroller

The serial port of the LTC3205 can be connected directly to an MC68HC11 style microcontroller's serial port. The microcontroller should be configured as the master device and its clock's idle state should be set to high (MSTR = 1, CPOL = 1 and CPHA = 1 for the MC68HC11 family). Figure 5 shows the recommended configuration and direction of data flow. Note that an additional I/O line is

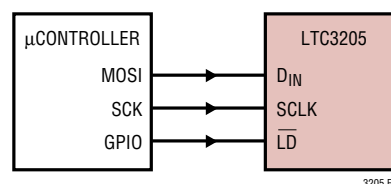

Figure 5. Microcontroller Interface

APPLICATIONS INFORMATION

necessary for $\overline{\text{LD}}$ to load the data once it has shifted into the device. Command data is latched into the command register on the falling edge of the LD signal. The LTC3205 will begin to act on new command data as soon as $\overline{\text{LD}}$ goes low. Any general purpose microcontroller I/O line can be configured to control the $\overline{\text{LD}}$ pin if the microcontroller doesn't provide this feature automatically.

V_{IN} , CPO Capacitor Selection

The style and value of capacitors used with the LTC3205 determine several important parameters such as regulator control-loop stability, output ripple and charge pump strength. To reduce noise and ripple, it is recommended that low equivalent series resistance (ESR) multilayer ceramic capacitors be used on both V_{IN} and CPO. Tantalum and aluminum capacitors are not recommended because of their high ESR. The value of the capacitor on CPO directly controls the amount of output ripple for a given load current. Increasing the size of this capacitor will reduce the output ripple. The peak-to-peak output ripple is approximately given by the expression:

$$V_{\text{RIPPLE-P}} \cong \frac{I_{\text{OUT}}}{3f_{\text{OSC}} \cdot C_{\text{OUT}}}$$

where f_{OSC} is the LTC3205's oscillator frequency (typically 800kHz) and C_{OUT} is the output charge storage capacitor on CPO. Both the style and value of the output capacitor can significantly affect the stability of the LTC3205. The LTC3205 uses a linear control loop to adjust the strength of the charge pump to match the current required at the output. The error signal of this loop is stored directly on the output charge storage capacitor. The charge storage capacitor also serves to form the dominant pole for the control loop. To prevent ringing or instability, it is important for the output capacitor to maintain at least 0.6 μF of capacitance over all conditions. Likewise, excessive ESR on the output capacitor will tend to degrade the loop stability of the LTC3205. The closed-loop output resistance of the LTC3205 is designed to be 0.6 Ω . For a 100mA load current change, the error signal will change by about 60mV. If the output capacitor has 0.6 Ω or more of ESR, the closed-loop frequency response will cease to roll off in a simple one-pole fashion and poor load transient response or instability could result. Multilayer ceramic chip

capacitors typically have exceptional ESR performance. MLCCs combined with a tight board layout will yield very good stability. As the value of C_{OUT} controls the amount of output ripple, the value of C_{IN} controls the amount of ripple present at the input pin (V_{IN}). The input current to the LTC3205 will be relatively constant while the charge pump is on either the input charging phase or the output charging phase but will drop to zero during the clock nonoverlap times. Since the nonoverlap time is small (~25ns), these missing "notches" will result in only a small perturbation on the input power supply line. Note that a higher ESR capacitor such as tantalum will have higher input noise due to the input current change times the ESR. Therefore, ceramic capacitors are again recommended for their exceptional ESR performance. Input noise can be further reduced by powering the LTC3205 through a very small series inductor as shown in Figure 6. A 10nH inductor will reject the fast current notches, thereby presenting a nearly constant current load to the input power supply. For economy, the 10nH inductor can be fabricated on the PC board with about 1cm (0.4") of PC board trace.

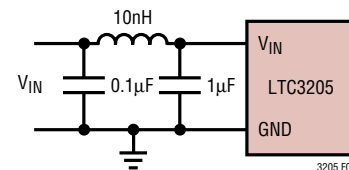

Figure 6. 10nH Inductor Used for Input Noise Reduction (Approximately 1cm of Wire)

Flying Capacitor Selection

Warning: A polarized capacitor such as tantalum or aluminum should never be used for the flying capacitors since their voltage can reverse upon start-up of the LTC3205. Ceramic capacitors should always be used for the flying capacitors.

The flying capacitor controls the strength of the charge pump. In order to achieve the rated output current it is necessary to have at least 0.7 μF of capacitance for each of the flying capacitors. Capacitors of different materials lose their capacitance with higher temperature and voltage at different rates. For example, a ceramic capacitor made of X7R material will retain most of its capacitance from -40°C to 85°C whereas a Z5U or Y5V style capacitor will

APPLICATIONS INFORMATION

lose considerable capacitance over that range. Z5U and Y5V capacitors may also have a very strong voltage coefficient causing them to lose 60% or more of their capacitance when the rated voltage is applied. Therefore, when comparing different capacitors, it is often more appropriate to compare the amount of achievable capacitance for a given case size rather than comparing the specified capacitance value. For example, over rated voltage and temperature conditions, a 1 μ F, 10V, Y5V ceramic capacitor in a 0603 case may not provide any more capacitance than a 0.22 μ F, 10V, X7R available in the same 0603 case. The capacitor manufacturer's data sheet should be consulted to determine what value of capacitor is needed to ensure minimum capacitances at all temperatures and voltages.

Table 4 shows a list of ceramic capacitor manufacturers and how to contact them:

Table 4. Recommended Capacitor Vendors

AVX	www.avxcorp.com
Kemet	www.kemet.com
Murata	www.murata.com
Taiyo Yuden	www.t-yuden.com
Vishay	www.vishay.com

For very light load applications, the flying capacitors may be reduced to save space or cost. The theoretical minimum output resistance of a 2:3 fractional charge pump is given by:

$$R_{OL(MIN)} \equiv \frac{1.5V_{IN} - V_{OUT}}{I_{OUT}} = \frac{1}{2f_{OSC}C_{FLY}}$$

where f_{OSC} is the switching frequency (800kHz typ) and C_{FLY} is the value of the flying capacitors. Note that the

charge pump will typically be weaker than the theoretical limit due to additional switch resistance, however for very light load applications, the above expression can be used as a guideline in determining a starting capacitor value.

Layout Considerations and Noise

Due to its high switching frequency and the transient currents produced by the LTC3205, careful board layout is necessary. A true ground plane and short connections to all capacitors will improve performance and ensure proper regulation under all conditions. Figure 7 shows the recommended layout configuration.

The flying capacitor pins $C1^+$, $C2^+$, $C1^-$ and $C2^-$ will have very high edge rate waveforms. The large dv/dt on these pins can couple energy capacitively to adjacent printed circuit board runs. Magnetic fields can also be generated if the flying capacitors are not close to the LTC3205 (i.e., the loop area is large). To decouple capacitive energy transfer, a Faraday shield may be used. This is a grounded PC trace between the sensitive node and the LTC3205 pins. For a high quality AC ground, it should be returned to a solid ground plane that extends all the way to the LTC3205

Power Efficiency

To calculate the power efficiency (η) of a white LED driver chip, the LED power should be compared to the input power. The difference between these two number represents lost power whether it is in the charge pump or the current sources. Stated mathematically, the power efficiency is given by:

$$\eta \equiv \frac{P_{LED}}{P_{IN}}$$

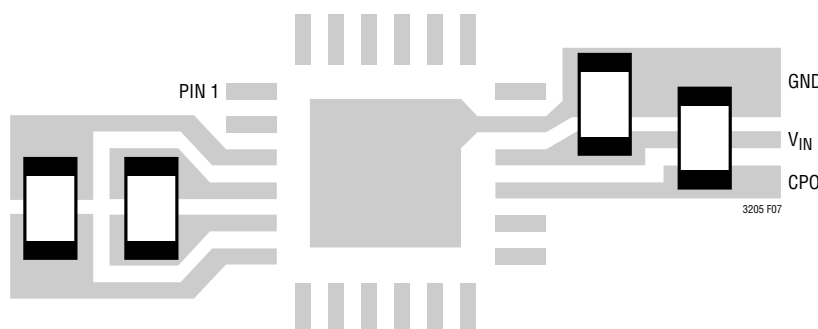

Figure 7. Optimum Single Layer PCB Layout

APPLICATIONS INFORMATION

The efficiency of the LTC3205 depends upon the mode in which it is operating. Recall that the LTC3205 operates as a pass switch, connecting V_{IN} to CPO until one of the LEDs on the main or sub displays drops out. This feature provides the optimum efficiency available for a given input voltage and LED forward voltage. When it is operating as a switch, the efficiency is approximated by:

$$\eta \equiv \frac{P_{LED}}{P_{IN}} = \frac{V_{LED} \cdot I_{LED}}{V_{IN} \cdot I_{IN}} \approx \frac{V_{LED}}{V_{IN}}$$

since the input current will be very close to the LED current.

At moderate to high output power, the quiescent current of the LTC3205 is negligible and the expression above is valid. For example, with $V_{IN} = 3.9V$, $I_{OUT} = 20mA \cdot 6$ LEDs and V_{LED} equal to 3.6V, the measured efficiency is 92.2%, which is very close to the theoretical 92.3% calculation.

Once an LED drops out, the LTC3205 switches into step-up mode. Employing the fractional ratio 2:3 charge pump, the LTC3205 provides more efficiency than would be achieved with a voltage doubling charge pump.

In 2:3 boost mode, the efficiency is similar to that of a linear regulator with an effective input voltage of 1.5 times the actual input voltage. This is because the input current

for a 2:3 fractional charge pump is approximately 1.5 times the load current. In an ideal 2:3 charge pump, the power efficiency would be given by:

$$\eta_{IDEAL} \equiv \frac{P_{LED}}{P_{IN}} = \frac{V_{LED} \cdot I_{LED}}{V_{IN} \cdot \frac{3}{2} I_{LED}} \approx \frac{V_{LED}}{1.5V_{IN}}$$

Using the RED, GREEN and BLUE Pins with Higher Currents

The RED, GREEN and BLUE current source pins can be used at higher current levels to provide features such as a flash or camera light. Given that the output impedance of the current source is approximately 3.3Ω when in saturation, more compliance voltage will be necessary to operate the device at higher LED currents. Figure 8 shows the current source accuracy of the RED, GREEN and BLUE pins as a function of the pin voltage for various high current settings.

Programming the I_{MS} or I_{RGB} pins for more than $75\mu A$ requires a higher supply voltage to support the extra current. Figure 9 shows the minimum input supply voltage required to support various levels of current on the I_{MS} and I_{RGB} pins.

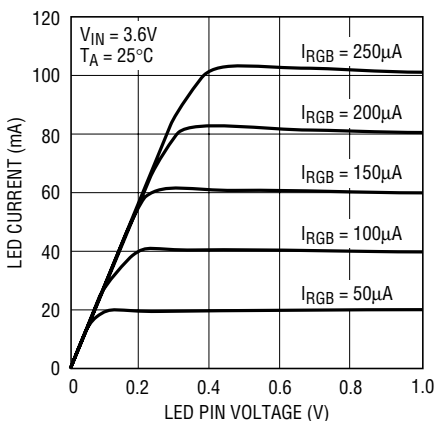

Figure 8. Compliance Voltage Required to get Higher LED Currents

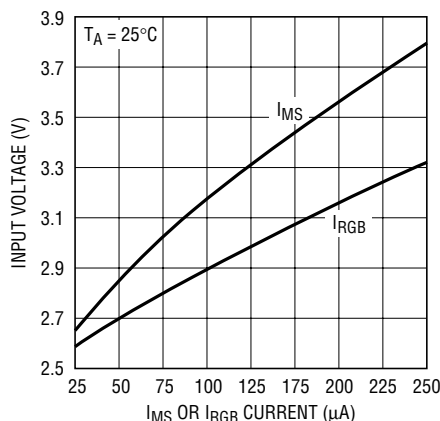

Figure 9. Input Supply Voltage Required to Support Higher Currents

APPLICATIONS INFORMATION

If the desired input voltage range is below the data shown in Figure 9, and a precise control of the LED current is desired, then a precision current source may be added to either the I_{MS} or I_{RGB} pins as shown in Figure 10.

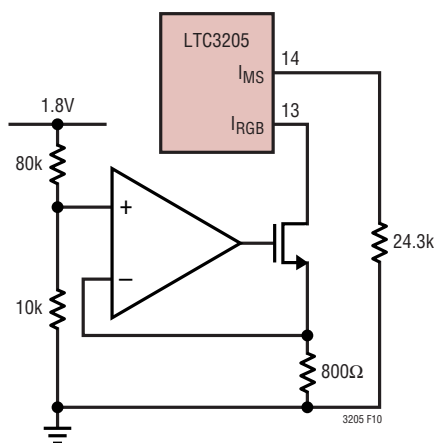

Figure 10. Precision Reference Current

Brightness Control

Although the LTC3205 has three exponentially spaced brightness settings for the main and sub displays, it is possible to control the brightness by alternative means. Figure 11 shows an example of how an external voltage source can be used to inject a current into the I_{MS} or I_{RGB} pins to control brightness. For example, if R_1 and R_2 are 50k, then the LED current would range from 20mA to 0mA as V_{CTRL} is swept from 0V to 2.5V.

Alternatively, if only digital outputs are available, the number of settings can be doubled from 3 to 6 by simply connecting V_{CTRL} to a digital signal. With a 1.8V logic supply, the circuit shown in Figure 12 has LED current settings of 2.5mA, 5mA, 7.5mA, 10mA, 15mA and 20mA. This topology can be extended to any number of bits and can also be applied to the RGB panel.

Finally, PWM brightness control can be achieved by applying a PWM signal to the I_{MS} programming resistor as shown in Figure 13. The signal should range from 0V (full on) to any voltage above 1.3V (full off).

Thermal Management

For higher input voltages and maximum output current, there can be substantial power dissipation in the LTC3205. If the junction temperature increases above approximately 160°C the thermal shutdown circuitry will automatically deactivate the output. To reduce the maximum junction temperature, a good thermal connection to the PC board is recommended. Connecting the PGND pin (exposed center pad) to a ground plane and maintaining a solid ground plane under the device can reduce the thermal resistance of the package and PC board considerably.

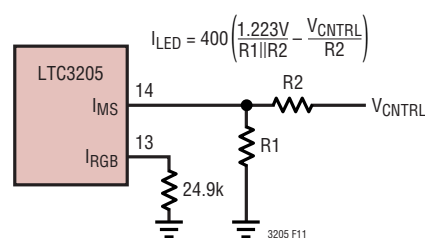

Figure 11. Alternative Linear Brightness Control

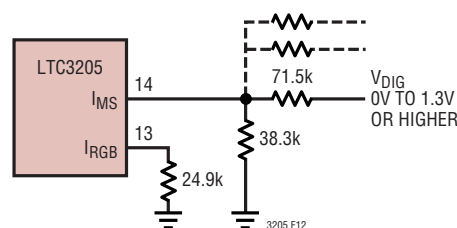

Figure 12. Alternative Digital Brightness Control

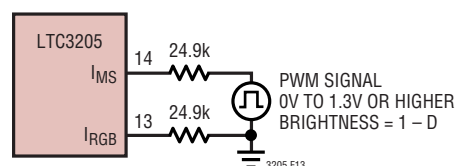
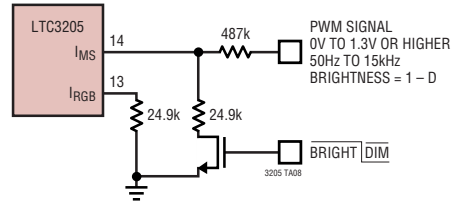

Figure 13. PWM Brightness Control of the MAIN and SUB Displays

TYPICAL APPLICATIONS

Ultralow Brightness MAIN and SUB Displays



All Charge Pump Main, Sub, RGB and Camera Light Controller

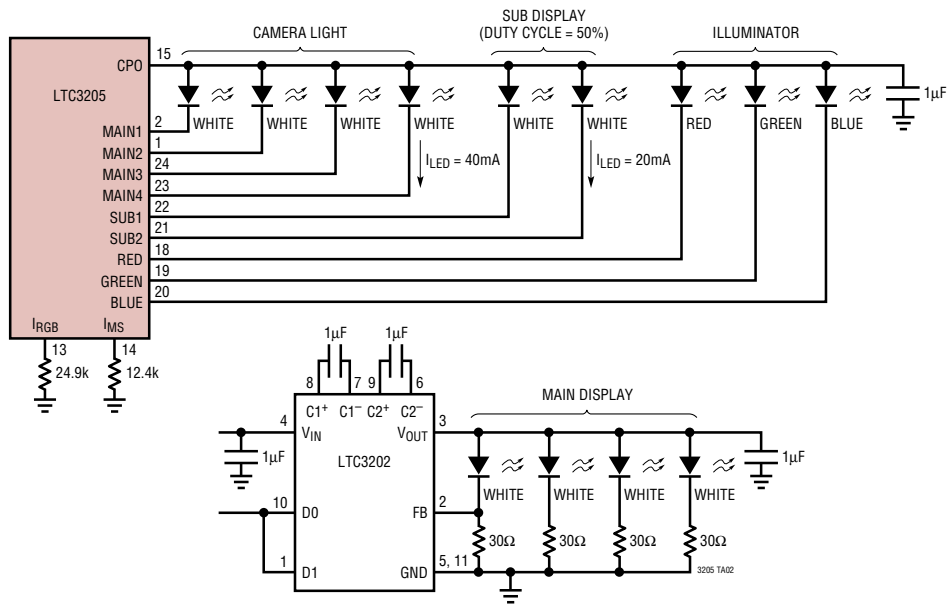

Main, Sub and Keypad Illumination

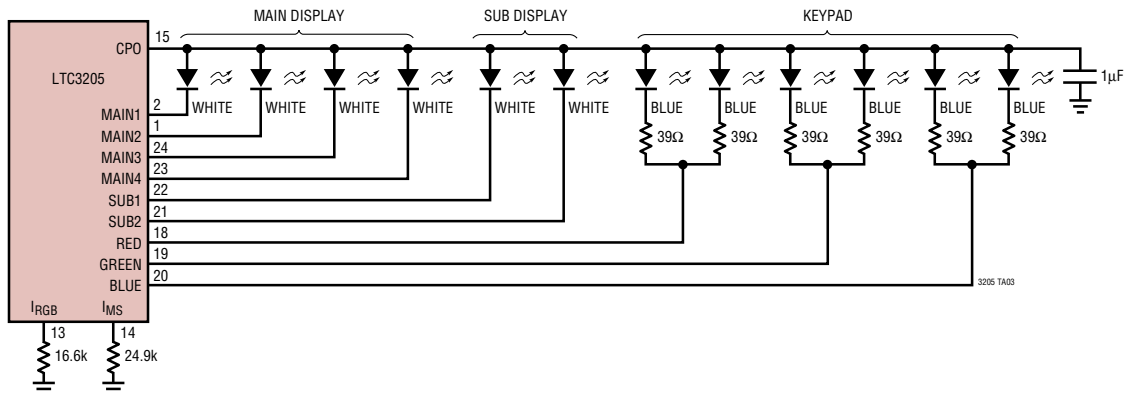

TYPICAL APPLICATIONS

4-LED Main Display Plus 160mA 4-LED Camera Light

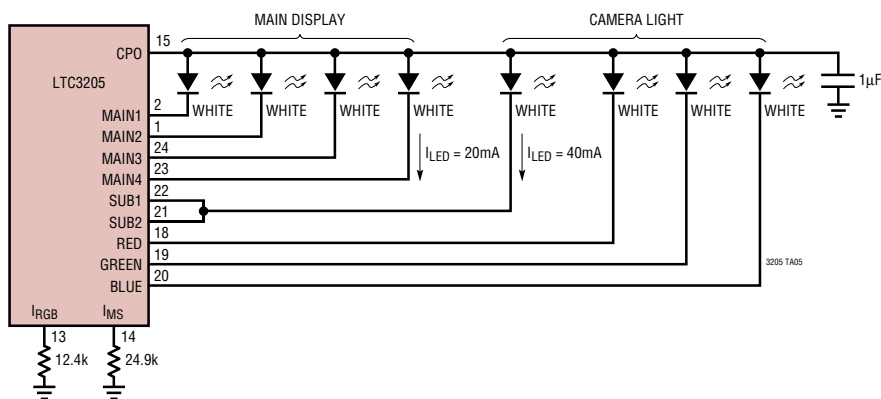

Main, Sub, RGB and Camera Light Controller

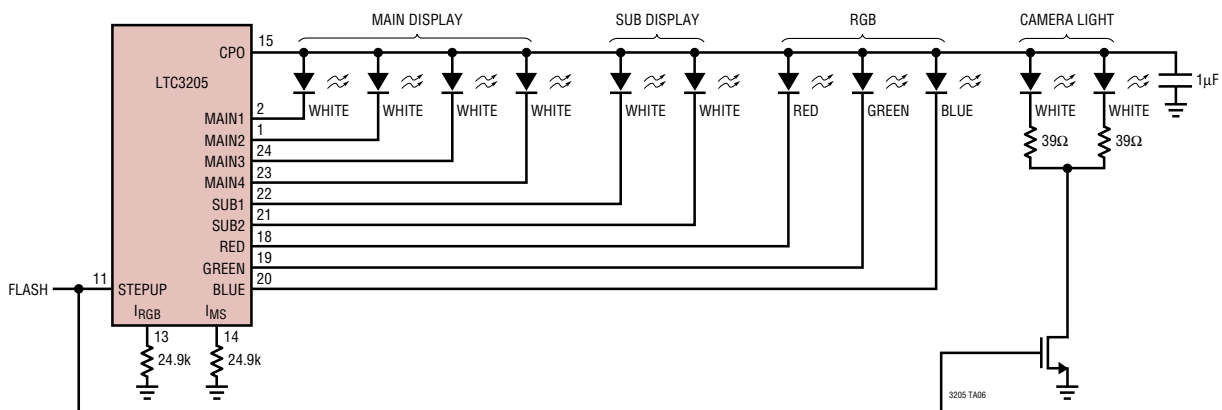

PACKAGE DESCRIPTION

UF Package
24-Lead Plastic QFN (4mm × 4mm)
(Reference LTC DWG # 05-08-1697)

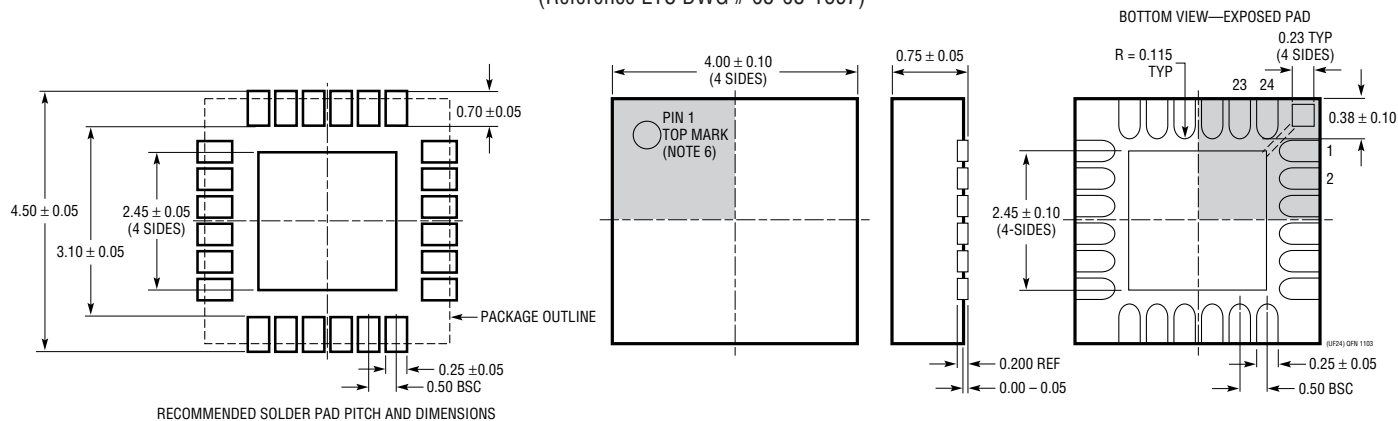

RECOMMENDED SOLDER PAD PITCH AND DIMENSIONS

- NOTE:
1. DRAWING PROPOSED TO BE MADE A JEDEC PACKAGE OUTLINE MO-220 VARIATION (WGGD-X)—TO BE APPROVED
 2. DRAWING NOT TO SCALE
 3. ALL DIMENSIONS ARE IN MILLIMETERS

4. DIMENSIONS OF EXPOSED PAD ON BOTTOM OF PACKAGE DO NOT INCLUDE MOLD FLASH. MOLD FLASH, IF PRESENT, SHALL NOT EXCEED 0.15mm ON ANY SIDE, IF PRESENT
5. EXPOSED PAD SHALL BE SOLDER PLATED
6. SHADED AREA IS ONLY A REFERENCE FOR PIN 1 LOCATION ON THE TOP AND BOTTOM OF PACKAGE

TYPICAL APPLICATION

Using the RGB Display as a Camera Light

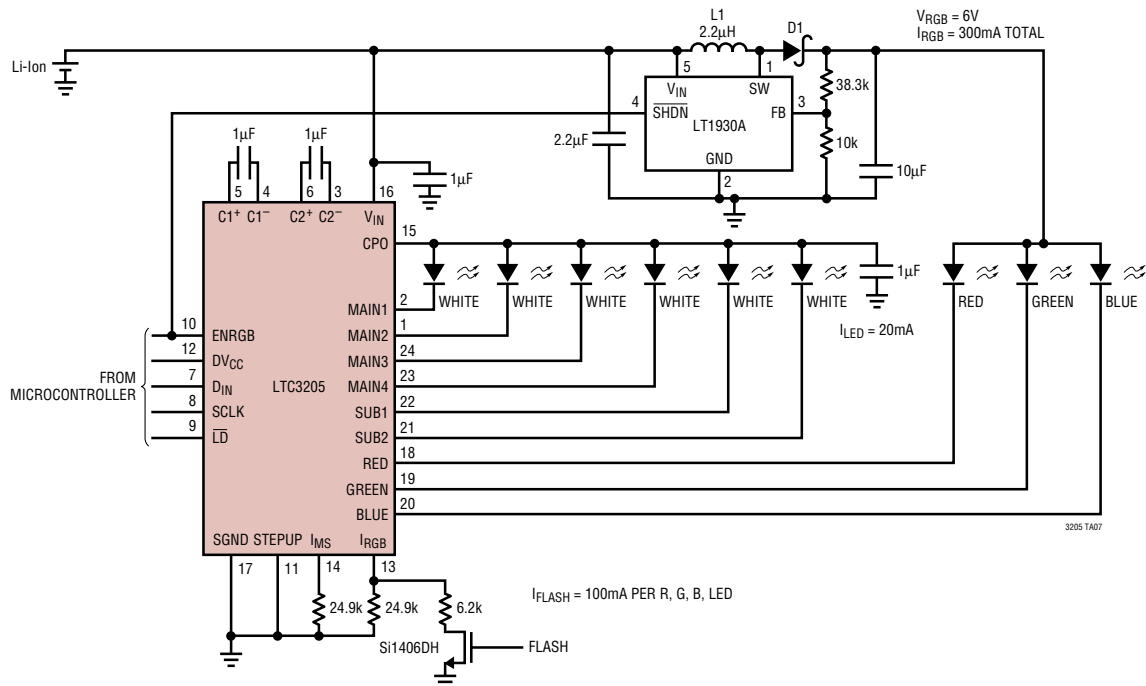

RELATED PARTS

PART NUMBER	DESCRIPTION	COMMENTS
LT [®] 1618	Constant Current, Constant Voltage, 1.4MHz High Efficiency Boost Regulator	Up to 16 White LEDs, V _{IN} : 1.6V to 18V, V _{OUT(MAX)} : 34V, I _Q : 1.8mA, I _{SD} : ≤1μA, 10-Lead MS
LTC1911-1.5	250mA (I _{OUT}), 1.5MHz High Efficiency Step-Down Charge Pump	75% Efficiency, V _{IN} : 2.7V to 5.5V, V _{OUT(MIN)} : 1.5V/1.8V, I _Q : 180μA, I _{SD} : ≤10μA, MS8
LT1932	Constant Current, 1.2MHz High Efficiency White LED Boost Regulator	Up to 8 White LEDs, V _{IN} : 1V to 10V, V _{OUT(MAX)} : 34V, I _Q : 1.2mA, I _{SD} : ≤1μA, ThinSOT [™]
LT1937	Constant Current, 1.2MHz High Efficiency White LED Boost Regulator	Up to 4 White LEDs, V _{IN} : 2.5V to 10V, V _{OUT(MAX)} : 34V, I _Q : 1.9mA, I _{SD} : ≤1μA, ThinSOT, SC70
LTC3200-5	Low Noise, 2MHz Regulated Charge Pump White LED Driver	Up to 6 White LEDs, V _{IN} : 2.7V to 4.5V, V _{OUT(MAX)} : 5V, I _Q : 8mA, I _{SD} : ≤1μA, ThinSOT
LTC3201	Low Noise, 1.7MHz Regulated Charge Pump White LED Driver	Up to 6 White LEDs, V _{IN} : 2.7V to 4.5V, V _{OUT(MAX)} : 5V, I _Q : 6.5mA, I _{SD} : ≤1μA, 10-Lead MS
LTC3202	Low Noise, 1.5MHz Regulated Charge Pump White LED Driver	Up to 8 White LEDs, V _{IN} : 2.7V to 4.5V, V _{OUT(MAX)} : 5V, I _Q : 5mA, I _{SD} : ≤1μA, 10-Lead MS
LTC3251	500mA (I _{OUT}), 1MHz to 1.6MHz Spread Spectrum Step-Down Charge Pump	85% Efficiency, V _{IN} : 3.1V to 5.5V, V _{OUT(MIN)} : 0.9V to 1.6V, I _Q : 9μA, I _{SD} : ≤1μA, 10-Lead MS
LTC3405/LTC3405A	300mA (I _{OUT}), 1.5MHz Synchronous Step-Down DC/DC Converter	95% Efficiency, V _{IN} : 2.7V to 6V, V _{OUT(MIN)} : 0.8V, I _Q : 20μA, I _{SD} : ≤1μA, ThinSOT
LTC3406/LTC3406B	600mA (I _{OUT}), 1.5MHz Synchronous Step-Down DC/DC Converter	95% Efficiency, V _{IN} : 2.5V to 5.5V, V _{OUT(MIN)} : 0.6V, I _Q : 20μA, I _{SD} : ≤1μA, ThinSOT
LTC3440	600mA (I _{OUT}), 2MHz Synchronous Buck-Boost DC/DC Converter	95% Efficiency, V _{IN} : 2.5V to 5.5V, V _{OUT(MIN)} : 2.5V, I _Q : 25μA, I _{SD} : ≤1μA, 10-Lead MS
LT3465/LT3465A	1.2MHz/2.7MHz with Internal Schottky	Up to 6 White LEDs, V _{IN} : 12.7V to 16V, V _{OUT(MAX)} : 34V, I _Q : 1.9mA, I _{SD} : <1μA, ThinSOT

ThinSOT is a trademark of Linear Technology Corporation.



Компания «ЭлектроПласт» предлагает заключение долгосрочных отношений при поставках импортных электронных компонентов на взаимовыгодных условиях!

Наши преимущества:

- Оперативные поставки широкого спектра электронных компонентов отечественного и импортного производства напрямую от производителей и с крупнейших мировых складов;
- Поставка более 17-ти миллионов наименований электронных компонентов;
- Поставка сложных, дефицитных, либо снятых с производства позиций;
- Оперативные сроки поставки под заказ (от 5 рабочих дней);
- Экспресс доставка в любую точку России;
- Техническая поддержка проекта, помощь в подборе аналогов, поставка прототипов;
- Система менеджмента качества сертифицирована по Международному стандарту ISO 9001;
- Лицензия ФСБ на осуществление работ с использованием сведений, составляющих государственную тайну;
- Поставка специализированных компонентов (Xilinx, Altera, Analog Devices, Intersil, Interpoint, Microsemi, Aeroflex, Peregrine, Syfer, Eurofarad, Texas Instrument, Miteq, Cobham, E2V, MA-COM, Hittite, Mini-Circuits, General Dynamics и др.);

Помимо этого, одним из направлений компании «ЭлектроПласт» является направление «Источники питания». Мы предлагаем Вам помощь Конструкторского отдела:

- Подбор оптимального решения, техническое обоснование при выборе компонента;
- Подбор аналогов;
- Консультации по применению компонента;
- Поставка образцов и прототипов;
- Техническая поддержка проекта;
- Защита от снятия компонента с производства.



Как с нами связаться

Телефон: 8 (812) 309 58 32 (многоканальный)

Факс: 8 (812) 320-02-42

Электронная почта: org@eplast1.ru

Адрес: 198099, г. Санкт-Петербург, ул. Калинина, дом 2, корпус 4, литера А.