

UP TO 3 POSITIONS WITH 3 OPTIONAL, INDEPENDENT LED LIGHT POSITIONS, 1.45 X .83 PANEL CUTOUT

Used in the heavy equipment, marine, process control and instrumentation markets the R2 rotary switch is an excellent replacement for rocker switches offering improved visual position indication, additional lighting options and different styling opportunities on front panels. The R2 series is a sealed, lighted rotary switch which snaps into a 1.45 x .83" industry standard rocker switch panel opening. The rotary knob snaps onto a shaft and can be installed by the panel builder for those desiring that flexibility. The R2 rotary switch provides up to 3 positions in all combinations of momentary and maintained action. It is capable of handling loads from logic level to 20 amps (resistive). Sealing is to IP68 (1 meter immersion) via a shaft o-ring seal in front and a potted base in the back. Termination options include .250" fast on, solder lug or a snap on modular connector. The R2 offers unique lighting options including up to three independent LED light positions which illuminate a lens on the rotary knob. This design provides more lighting options than traditional rocker switches, handles the full range of electrical loads and is robust enough to survive in the most demanding applications.



## Quality Features:

- Sealed watertight per IP68
- Snap-in panel mounting into industry standard 1.45 x .83 panel cutout
- Unique lighting options up to three independent LED light positions
- Plastic or "Soft Touch" knob options available
- 2 or 3 positions in all combinations of momentary and maintained action
- Termination options include .250" fast on, solder lug or a snap on modular connector

Standard Characteristics/Ratings:			
<b>OPERATIONAL:</b>			
<b>Mechanical Life:</b>	100,000 cycles		
<b>Seal:</b>	Watertight to IP68		
<b>Temperature Range:</b>	-40C to +85C		
<b>MATERIALS:</b>			
<b>Case/Base:</b>	Thermoplastic		
<b>Knob:</b>	Thermoplastic		
<b>Terminals:</b>	Copper alloy; silver plate; gold plate for low level		
<b>Contacts:</b>	Silver alloy; Gold plate for low level		
<b>Panel Thickness:</b>	.025 min to .187 max		
<b>Mounting:</b>	Snap in from front 1.45 x .83 panel cutout		
<b>ELECTRICAL:</b>			
<b>LOAD Type</b>	<b>Current Rating</b>		<b>LIFE (Min.)</b>
	<b>12 &amp; 28 VDC</b>	<b>110 VAC</b>	
Resistive	20 amps	16 amps	25,000 cycles
Inductive	15 amps	15 amps	25,000 cycles
Lamp	4 amps	4 amps	25,000 cycles
<b>Motor Load:</b>	1/2 HP at 110 vac		

# ROTARY SWITCH

UP TO 3 POSITIONS WITH 3 OPTIONAL, INDEPENDENT LED LIGHT POSITIONS, 1.45 X .83 PANEL CUTOUT

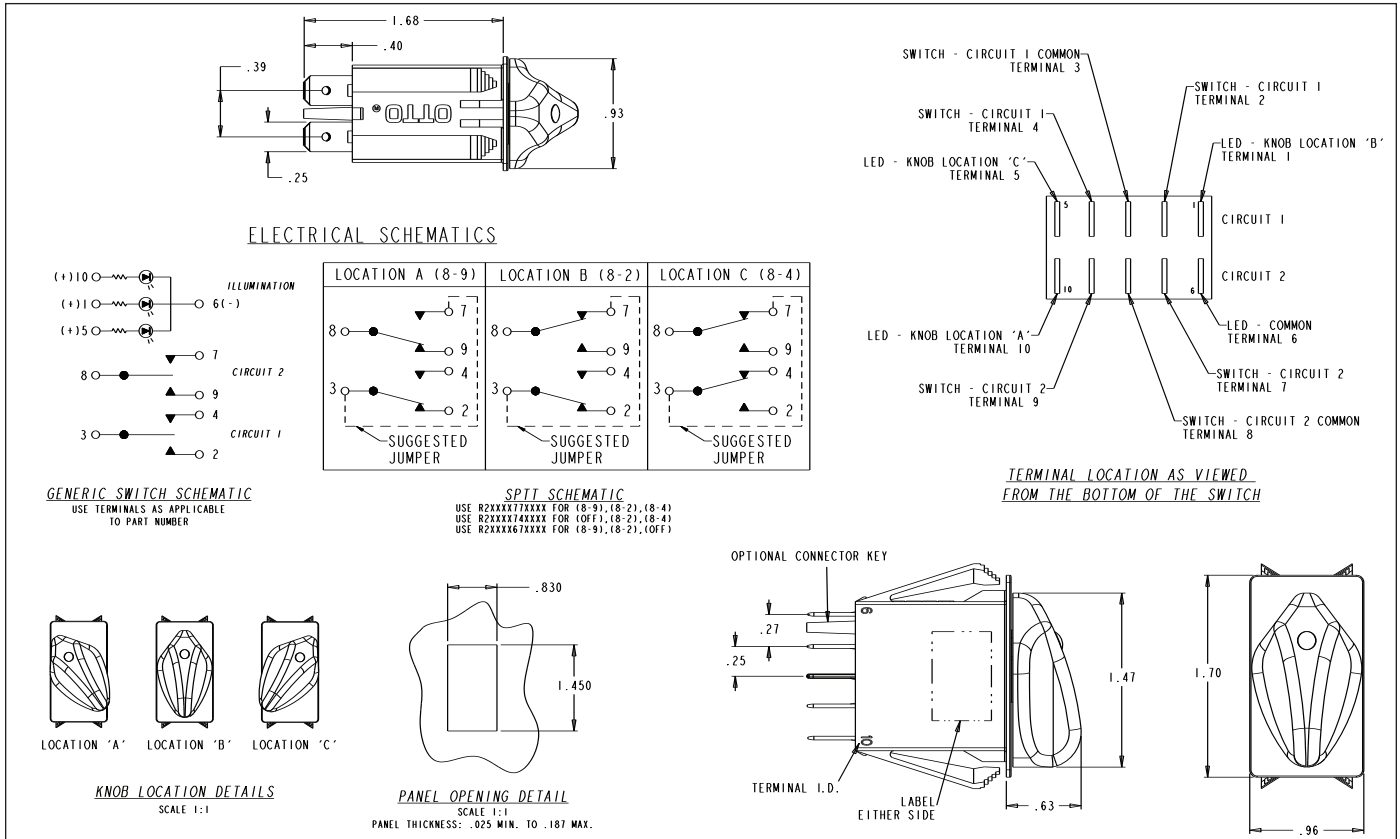

R2	X	X	X	X	X	X	X	X	X
----	---	---	---	---	---	---	---	---	---

TERMINAL STYLE / SWITCH RATING 3RD CHARACTER
A WITHOUT TERMINAL BARRIERS, WITH CONNECTOR KEYING PIN, STANDARD RATING
B WITHOUT TERMINAL BARRIERS, WITHOUT CONNECTOR KEYING PIN, STANDARD RATING
C WITHOUT TERMINAL BARRIERS, WITH CONNECTOR KEYING PIN, LOW LEVEL RATING
D WITHOUT TERMINAL BARRIERS, WITHOUT CONNECTOR KEYING PIN, LOW LEVEL RATING

KNOB COLOR AND TEXTURE 4TH CHARACTER
A BLACK PLASTIC
B BLACK "SOFT TOUCH"
C WHITE PLASTIC
D WHITE "SOFT TOUCH"

SWITCH CONFIGURATIONS 5TH AND 6TH CHARACTERS				
	KNOB LOCATIONS	SWITCH ACTIONS		
		KNOB LOCATION A	KNOB LOCATION B	KNOB LOCATION C
11	2 POSITION	A/B	MAINTAIN	MAINTAIN
12	2 POSITION	A/B	MAINTAIN	MOMENTARY
13	2 POSITION	A/B	MOMENTARY	MAINTAIN
21	2 POSITION	A/C	MAINTAIN	MAINTAIN
22	2 POSITION	A/C	MAINTAIN	MOMENTARY
23	2 POSITION	A/C	MOMENTARY	MAINTAIN
31	2 POSITION	B/C	MAINTAIN	MAINTAIN
32	2 POSITION	B/C	MAINTAIN	MOMENTARY
33	2 POSITION	B/C	MOMENTARY	MAINTAIN
44	3 POSITION	A/B/C	MAINTAIN	MAINTAIN
45	3 POSITION	A/B/C	MOMENTARY	MAINTAIN
46	3 POSITION	A/B/C	MAINTAIN	MOMENTARY
47	3 POSITION	A/B/C	MOMENTARY	MAINTAIN

SWITCH CIRCUIT 1 - TERMINALS 2, 3, 4 7TH CHARACTER			
KNOB LOCATION A	KNOB LOCATION B	KNOB LOCATION C	
2 POSITION SWITCH (KNOB LOCATIONS A/B)			
1	3-2	OFF	----
2	OFF	3-4	----
3	3-2	3-4	----
2 POSITION SWITCH (KNOB LOCATIONS A/C)			
1	3-2	----	OFF
2	OFF	----	3-4
3	3-2	----	3-4
2 POSITION SWITCH (KNOB LOCATIONS B/C)			
1	----	3-2	OFF
2	----	OFF	3-4
3	----	3-2	3-4
3-POSITION SWITCH			
4	OFF	3-4	3-4
5	3-2	OFF	3-4
6	3-2	3-2	OFF
7	3-2	3-2	3-4
8	3-2	OFF	OFF
9	OFF	OFF	3-4

SWITCH CIRCUIT 2 - TERMINALS 7, 8, 9 8TH CHARACTER			
KNOB LOCATION A	KNOB LOCATION B	KNOB LOCATION C	
N NONE (SINGLE POLE SWITCH)			
2 POSITION SWITCH (KNOB LOCATIONS A/B)			
1	8-9	OFF	----
2	OFF	8-7	----
3	8-9	8-7	----
2 POSITION SWITCH (KNOB LOCATIONS A/C)			
1	8-9	----	OFF
2	OFF	----	8-7
3	8-9	----	8-7
2 POSITION SWITCH (KNOB LOCATIONS B/C)			
1	----	8-9	OFF
2	----	OFF	8-7
3	----	8-9	8-7
3-POSITION SWITCH			
4	OFF	8-7	8-7
5	8-9	OFF	8-7
6	8-9	8-9	OFF
7	8-9	8-7	8-7
8	8-9	OFF	OFF
9	OFF	OFF	8-7

LOCATION 'C' LIGHT SOURCE COLOR 12TH CHARACTER			
N	1	2	3
N	NONE	RED	GREEN
1	RED	GREEN	AMBER
2	GREEN	AMBER	NONE
3	AMBER	NONE	NONE

LOCATION 'B' LIGHT SOURCE COLOR 11TH CHARACTER			
N	1	2	3
N	NONE	RED	GREEN
1	RED	GREEN	AMBER
2	GREEN	AMBER	NONE
3	AMBER	NONE	NONE

LOCATION 'A' LIGHT SOURCE COLOR 10TH CHARACTER			
N	1	2	3
N	NONE	RED	GREEN
1	RED	GREEN	AMBER
2	GREEN	AMBER	NONE
3	AMBER	NONE	NONE

LIGHT SOURCE VOLTAGE 9TH CHARACTER			
N	A	B	C
N	NONE	2 V	6 V
A	2 V	6 V	12 V
B	6 V	12 V	24 V
C	12 V	24 V	NONE
D	24 V	NONE	NONE



Компания «ЭлектроПласт» предлагает заключение долгосрочных отношений при поставках импортных электронных компонентов на взаимовыгодных условиях!

Наши преимущества:

- Оперативные поставки широкого спектра электронных компонентов отечественного и импортного производства напрямую от производителей и с крупнейших мировых складов;
- Поставка более 17-ти миллионов наименований электронных компонентов;
- Поставка сложных, дефицитных, либо снятых с производства позиций;
- Оперативные сроки поставки под заказ (от 5 рабочих дней);
- Экспресс доставка в любую точку России;
- Техническая поддержка проекта, помощь в подборе аналогов, поставка прототипов;
- Система менеджмента качества сертифицирована по Международному стандарту ISO 9001;
- Лицензия ФСБ на осуществление работ с использованием сведений, составляющих государственную тайну;
- Поставка специализированных компонентов (Xilinx, Altera, Analog Devices, Intersil, Interpoint, Microsemi, Aeroflex, Peregrine, Syfer, Eurofarad, Texas Instrument, Miteq, Cobham, E2V, MA-COM, Hittite, Mini-Circuits, General Dynamics и др.);

Помимо этого, одним из направлений компании «ЭлектроПласт» является направление «Источники питания». Мы предлагаем Вам помощь Конструкторского отдела:

- Подбор оптимального решения, техническое обоснование при выборе компонента;
- Подбор аналогов;
- Консультации по применению компонента;
- Поставка образцов и прототипов;
- Техническая поддержка проекта;
- Защита от снятия компонента с производства.



#### Как с нами связаться

**Телефон:** 8 (812) 309 58 32 (многоканальный)

**Факс:** 8 (812) 320-02-42

**Электронная почта:** [org@eplast1.ru](mailto:org@eplast1.ru)

**Адрес:** 198099, г. Санкт-Петербург, ул. Калинина, дом 2, корпус 4, литера А.