

Applications

- Automotive
- Instrumentation
- White goods
- Telecommunications

Benefits

- RoHS Compliant
- Halogen and Lead Free
- Sharp detection feeling
- Compact Size

JJ Series – Detector Switches



TE Connectivity is pleased to introduce its JJ Series of Detector Switches, suitable for a wide variety of applications given their several presentations ranging from horizontal or vertical actuated options as well as Gull-winged, J-leaded and Through-Hole mounting possibilities.

The Detector Switches will be offered in a wide range of sizes giving the possibility for countless applications going from automotive to telecommunications.

JJ Series – Family Classification

Series	Body Size
JJA	3.5x2.8 mm
JJB	3.5x2.98 mm
JJC	3.5x3.3 mm
JJD	4.2x3.6 mm
JJE	4.7x3.5 mm
JJF	4.7x3.8 mm
JJG	5.7x4.0 mm (High-Rating)
JJH	5.7x4.0 mm (Standard-Rating)
JJI	5.0x4.4 mm
JJJ	6.0x4.85 mm / 5.5x4.7 mm
JJK	6.3x3.0 mm
JJL	6.5x3.9 mm
JJM	5.7x4.0 mm
JJN	5.7x4.0 mm (Wedge)
JJO	10.0x3.8 mm
JJP	10.6x10.0 mm

JJJ Family – 6.0x4.85 mm / 5.5x4.7 mm

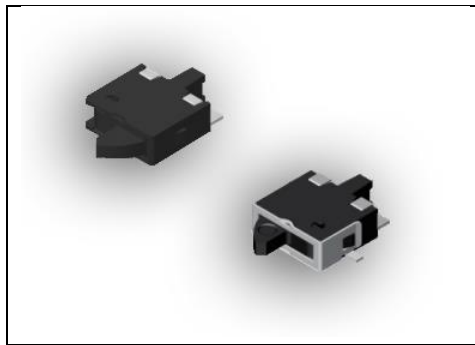
	Contact Rating	50mA, 20VDC
	Contact Resistance	1Ω Max.
	Insulation Resistance	100MΩ Min. 100VDC
	Dielectric Strength	100VAC/1 minute
	Operating Force	50gF Max.
	Travel	2.15mm
	Operating Life	100,000 cycles
	Operating Temperature	-10°C to 60°C
	Storage Temperature	-20°C to 70°C

Features	Applications
<ul style="list-style-type: none"> • Left or Right operation direction • Low profile • Grounded and Ungrounded options 	<ul style="list-style-type: none"> • Close/Open detection • White goods • Automotive

Circuit

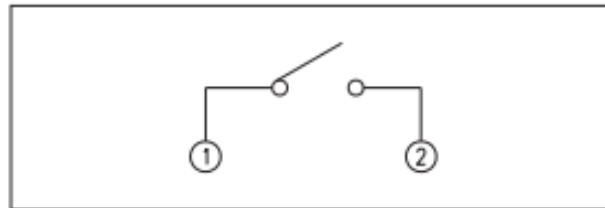

How To Order

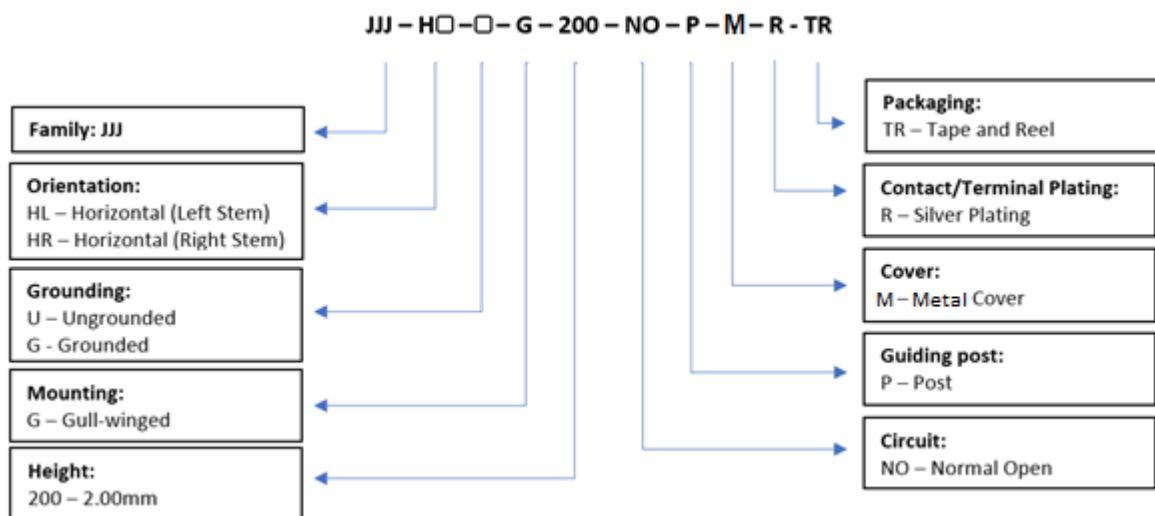

Diagrams

-Ungrounded

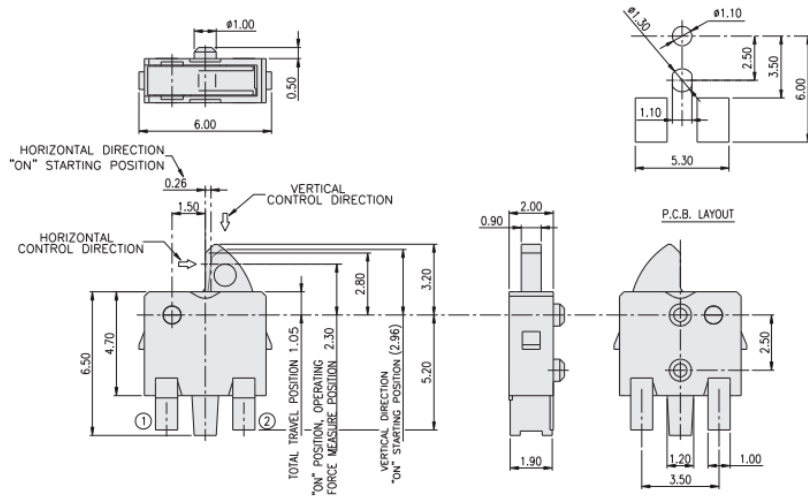

-Grounded

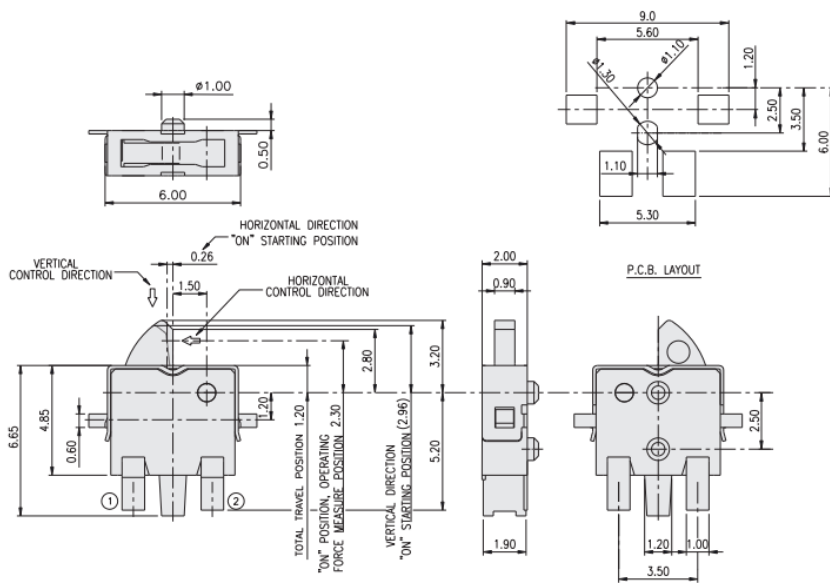

PN List

Smart PN	Orientation	Grounding	Mounting	Height	Circuit	Guiding Post	Cover	Plating	Packaging	MOQ	TE PN
JJHLGG200NOPMRTR	Horizontal (Left Stem)	Grounded	Gull-winged	2.00mm	NO	Post	Metal	Silver	Tape and Reel	2,000	2331401-1
JJHLUG200NOPMRTR	Horizontal (Left Stem)	Ungrounded	Gull-winged	2.00mm	NO	Post	Metal	Silver	Tape and Reel	3,000	2331405-1
JJHRGG200NOPMRTR	Horizontal (Right Stem)	Grounded	Gull-winged	2.00mm	NO	Post	Metal	Silver	Tape and Reel	2,000	2331406-1
JJHRUG200NOPMRTR	Horizontal (Right Stem)	Ungrounded	Gull-winged	2.00mm	NO	Post	Metal	Silver	Tape and Reel	3,000	2331407-1

1. Style

“Detector Switches” are mainly used as signal switches of electric devices, with the general requirements of mechanical and electrical characteristic.

1.1 Operating Temperature Range: -10°C to 60°C

1.2 Storage Temperature Range: -20°C to 70°C

1.3 The shelf life of product is within 6 months.

2. Current Range: 50mA, 20VDC

3. Type of Actuation: Auto Return

4. Test Sequence:

	Item	Description	Test Conditions	Requirements
Appearance	1	Visual Examination	Physical inspection without applying any external forces.	There shall be no defects that affect the serviceability of the product.
Electric Performance	2	Contact Resistance	Actuate the switch (2.3mm) and measure contact resistance using a micro-Ohmmeter.	1Ω Max.
	3	Insulation Resistance	Measurements shall be made at 100 VDC potential between terminals and cover.	100MΩ Min.
	4	Dielectric Withstanding Voltage	Apply 100 VAC (50Hz or 60Hz) between terminals and cover for 1 minute.	There shall be no breakdown or flashover
	5	Capacitance	Capacitance shall be measured at 1 MHz between terminals.	5 pF Max.



Mechanical Performance	6	Operating Force	As the specification shows operating force is measured.	50gF Max. (0.49N Max.)
	7	Contact (On) point	-----	As the specification shows ON start position
	8	Stop Strength	Apply vertical static load of 2KgF in the direction of stem operation for a period of 60 seconds.	As shown in items 2 through 7 above.
	9	Solder Heat Resistance	(See chart below)	1) Shall be free from pronounced backlash and falling-off or breakage terminals 2) As shown in item 4 to 5 3) Contact Resistance: 10Ω Max. 4) Insulation Resistance: 10MΩ Min.
	10	Vibration	Test per Method 201A of MIL-STD-202F 1) Swing distance=1.5mm 2) Frequency: 10-55-10Hz in 1-min/cycle. 3) Direction: 3 vertical directions including the directions of operation 4) Test time: 2 hours each direction	1) As shown in item 4 to 5 2) Contact Resistance: 10Ω Max. 3) Insulation Resistance: 10MΩ Min.
	11	Shock	Test per Method 213B condition A of MIL-STD-202F 1) Acceleration; 50G 2) Action time:11±1m seconds 3) Testing Direction: 6 sides 4) Test Cycle: 3 times in each direction	1) As shown in item 4 to 5 2) Contact Resistance: 10Ω Max. 3) Insulation Resistance: 10MΩ Min.
Durability	12	Operating Life	Tested as follows: 1) 5mA, 5 VDC resistive load 2) Apply a static load in the direction of operation equal to the operating force to the center of the stem. 3) Rate of Operation: 20 to 25 operations per minute. 4) Cycle of Operation: 100,000 cycles Min.	1) As shown in item 4 to 5 2) Contact Resistance: 10Ω Max. 3) Insulation Resistance: 10MΩ Min.

Water-Proof	13	Resistance Low Temperature	Following the test set forth below the sample shall be left in normal temperature and humidity conditions for 1 hour before the measurements are made: 1) Temperature: $-40\pm 2^{\circ}\text{C}$ 2) Time: 96 hours	1) As shown in item 4 to 5 2) Contact Resistance: 10Ω Max. 3) Insulation Resistance: $10\text{M}\Omega$ Min.
	14	Heat Resistance	Following the test set forth below the sample shall be left in normal temperature and humidity conditions for 1 hour before the measurements are made: 1) Temperature: $85\pm 2^{\circ}\text{C}$ 2) Time: 96 hours	
	15	Humidity Resistance	Following the test set forth below the sample shall be left in normal temperature and humidity conditions for 1 hour before the measurements are made: 1) Temperature: $40\pm 2^{\circ}\text{C}$ 2) Relative Humidity: $90\sim 95\%$ 3) Time: 96 hours	1) As shown in item 4 to 8 2) Insulation Resistance: $10\text{M}\Omega$ Min.

5. Soldering Conditions:

■ Recommended Soldering Profile for the JJJ Series

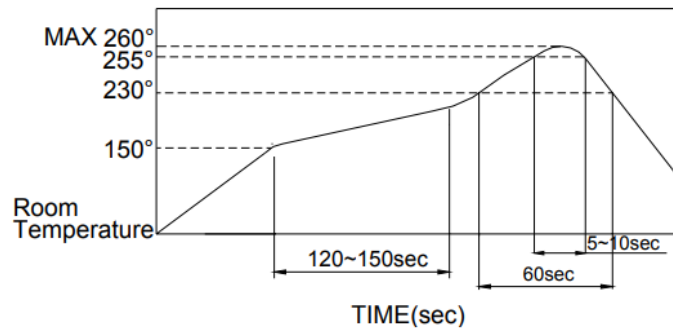

■ The temperatures defined above are the temperatures measured on the surface of the Printed Circuit Board. There are cases where the printed circuit board's temperature differs greatly from the temperature of the switch. Critical note: the switch's surface temperature must not exceed 260°C .

■ Manual Soldering

Soldering Temperature: 350°C Max.
Continuous Soldering Time: 5 second Max.

■ Precautions in Handling

- Care must be taken to ensure excess flux on the top surface of the printed circuit board does not adhere to the switch.
- Do not wash the switch.

■ Recommended storage conditions:

Store the products in the original packaging material. After opening the package, the remaining products must be stored in the appropriate moisture-proof & airtight environment.

Do not store the switch in the following environment or it may affect performance and solderability:

1. temperatures below -10° C to 40°C & humidity at 85% (min)
2. environment with corrosive gas
3. storage over 6 months
4. place in direct sunlight



Компания «ЭлектроПласт» предлагает заключение долгосрочных отношений при поставках импортных электронных компонентов на взаимовыгодных условиях!

Наши преимущества:

- Оперативные поставки широкого спектра электронных компонентов отечественного и импортного производства напрямую от производителей и с крупнейших мировых складов;
- Поставка более 17-ти миллионов наименований электронных компонентов;
- Поставка сложных, дефицитных, либо снятых с производства позиций;
- Оперативные сроки поставки под заказ (от 5 рабочих дней);
- Экспресс доставка в любую точку России;
- Техническая поддержка проекта, помощь в подборе аналогов, поставка прототипов;
- Система менеджмента качества сертифицирована по Международному стандарту ISO 9001;
- Лицензия ФСБ на осуществление работ с использованием сведений, составляющих государственную тайну;
- Поставка специализированных компонентов (Xilinx, Altera, Analog Devices, Intersil, Interpoint, Microsemi, Aeroflex, Peregrine, Syfer, Eurofarad, Texas Instrument, Miteq, Cobham, E2V, MA-COM, Hittite, Mini-Circuits, General Dynamics и др.);

Помимо этого, одним из направлений компании «ЭлектроПласт» является направление «Источники питания». Мы предлагаем Вам помощь Конструкторского отдела:

- Подбор оптимального решения, техническое обоснование при выборе компонента;
- Подбор аналогов;
- Консультации по применению компонента;
- Поставка образцов и прототипов;
- Техническая поддержка проекта;
- Защита от снятия компонента с производства.



Как с нами связаться

Телефон: 8 (812) 309 58 32 (многоканальный)

Факс: 8 (812) 320-02-42

Электронная почта: org@eplast1.ru

Адрес: 198099, г. Санкт-Петербург, ул. Калинина, дом 2, корпус 4, литера А.