

# TS1110 Electronic Circuit Breaker and TS1107 Current Limiter User's Guide

The TS1110 combines a very low power bidirectional current-sense amplifier (CSA) with a circuit breaker feature. The circuit breaker feature is supplied within the TS1110 as an FET control that drives the gate drive of an external P-channel MOSFET, disconnecting the load from the power supply. The TS1110 provides a comparator that can be used for current limit detection with a latch-capable output. A digital SIGN output that indicates the direction of current flow depending on the external connections to the RS+ and RS- input terminals is also provided. The TS1110 requires a very low 0.68  $\mu\text{A}$  CSA and 1.16  $\mu\text{A}$  VDD supply current while combining a 150  $\mu\text{V}$ (MAX) input offset voltage with a 0.6% gain error (MAX) for high-precision current measurements. The TS1110 provides a buffered CSA output, which can be connected with an RC Filter to reduce noise.

The TS1107 Current Limiter is a subset of the TS1110 Electronic Circuit Breaker and provides the same functionality minus the load disconnect feature. The TS1107 combines the very low power bidirectional current-sense amplifier (CSA) with a latch-capable current limiter comparator featuring an adjustable current threshold. The TS1107's CSA buffered output plus the current limiter comparator require a very low nominal supply current of 1.15  $\mu\text{A}$ .

## KEY FEATURES

- $R_{\text{SENSE}}$ : 50  $\text{m}\Omega \pm 0.5\%$
- External Circuit Breaker PMOS Included
- Adjustable Reference for Current Limiter
- Compatible for Both Gain Options
  - 20 V/V
  - 200 V/V

## ORDERING INFORMATION

- TS1110-20DB
- TS1110-200DB
- TS1107-20DB
- TS1107-200DB

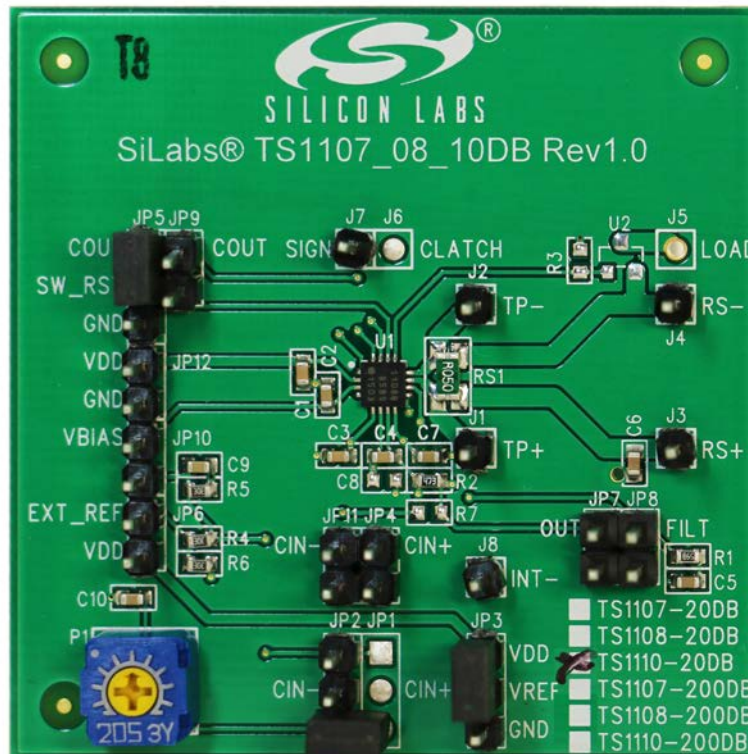

## 1. TS1110-EVB Description

The TS1110 Evaluation Board is intended for evaluating the circuit breaker feature of the TS1110. The evaluation board includes a variable reference scheme so that the threshold for the current limit comparator can be adjusted. The jumper, JP1, can be connected so that the included potentiometer can be used to adjust the threshold. A P-channel MOSFET is included, enabling the circuit breaker feature. When CLATCH is tied HIGH, the current limit comparator's output, COUT, indicates when the load has exceeded the current limit threshold and has thus been disconnected from the power supply. The Quick Start Procedure details two different load connections. The first load connection corresponds to a load under the current limiter's threshold, while the second load connection results in the current limiter's output enabling the circuit breaker.

**Table 1.1. Component List**

Designation	Quantity	Description
U1	1	TS1110-20, TS1110-200
U2	1	DMP2066LSN-7
RS1	1	50 mΩ ± 0.5%, 1/2 W (1206)
C1, C6	2	1 μF ± 10%, 10 V (0603)
C2, C7, C9, C10	4	0.1 μF ± 10%, 10 V (0603)
C5	1	0.47 μF ± 10%, 10 V (0603)
C8	1	1 nF ± 10%, 25 V (0603)
R1	1	4.02 kΩ ± 1%, 1/16 W (0603)
R3	1	1 MΩ ±1%, 1/16 W (0603)
R4, R5, R6	3	2 MΩ ±1%, 1/10 W (0603)
R7	1	0 Ω, 1 A (0603)
J1, J2, J3, J4, J5, J6, J7	7	Header 1x1
JP1, JP3	2	Header 1x3
JP4, JP6, JP7, JP8, JP9, JP10, JP11, JP12	8	Jumper
JS1, JS4	2	Jumper Shunt

## 2. TS1110-EVB Quick Start Procedure

### Required Equipment

- 3 V Power Supply or 3 V Battery
- 2 Digital Multimeters
- 1 Potentiometer

To use the TS1110 evaluation board, perform the following steps:

1. Configure JP3 so that the Jumper Shunt is connecting VDD to VREF. Configure JP1 so that the Jumper Shunt is connecting CIN+ to the bottom header.
2. Connect a Jumper Shunt so that EXT\_REF is connected to VDD.
3. Connect CLATCH to GND.
4. Connect the 3 V power source to RS+ and VDD.
5. Use a voltmeter to measure the V<sub>BIAS</sub> and the CIN+ voltage. V<sub>BIAS</sub> should be 50% of VDD, 1.5 V. CIN+ should be 40% of VDD, 1.2 V. The P1 potentiometer can be adjusted so that the CIN+ voltage can be increased or decreased.
6. Once CIN+ and V<sub>BIAS</sub> voltages are confirmed, connect CLATCH to VDD.
7. Connect a voltmeter to measure V<sub>OUT</sub>. With no load connected V<sub>OUT</sub> should be equal to V<sub>BIAS</sub>. The expression for the V<sub>OUT</sub> output voltage is defined by:

$$V_{OUT} = V_{BIAS} - (GAIN \times I_{SENSE} \times R_{SENSE})$$

8. Connect a voltmeter to measure COUT. COUT should be LOW.
9. Connect an ammeter in series from LOAD to a potentiometer. Adjust the POT until the ammeter reads:
  - TS1110-20: 200 mA
  - TS1110-200: 20 mA

V<sub>OUT</sub> should equal 1.3 V and COUT should be LOW.

10. To enable the circuit breaker, adjust the LOAD POT until the ammeter reads a value greater than:

- TS1110-20: 300 mA
- TS1110-200: 30 mA

Once COUT transitions to HIGH, V<sub>OUT</sub> should read 1.5V and the ammeter measurement should read 0mA signaling that the P-channel FET has disconnected the load from the power supply.

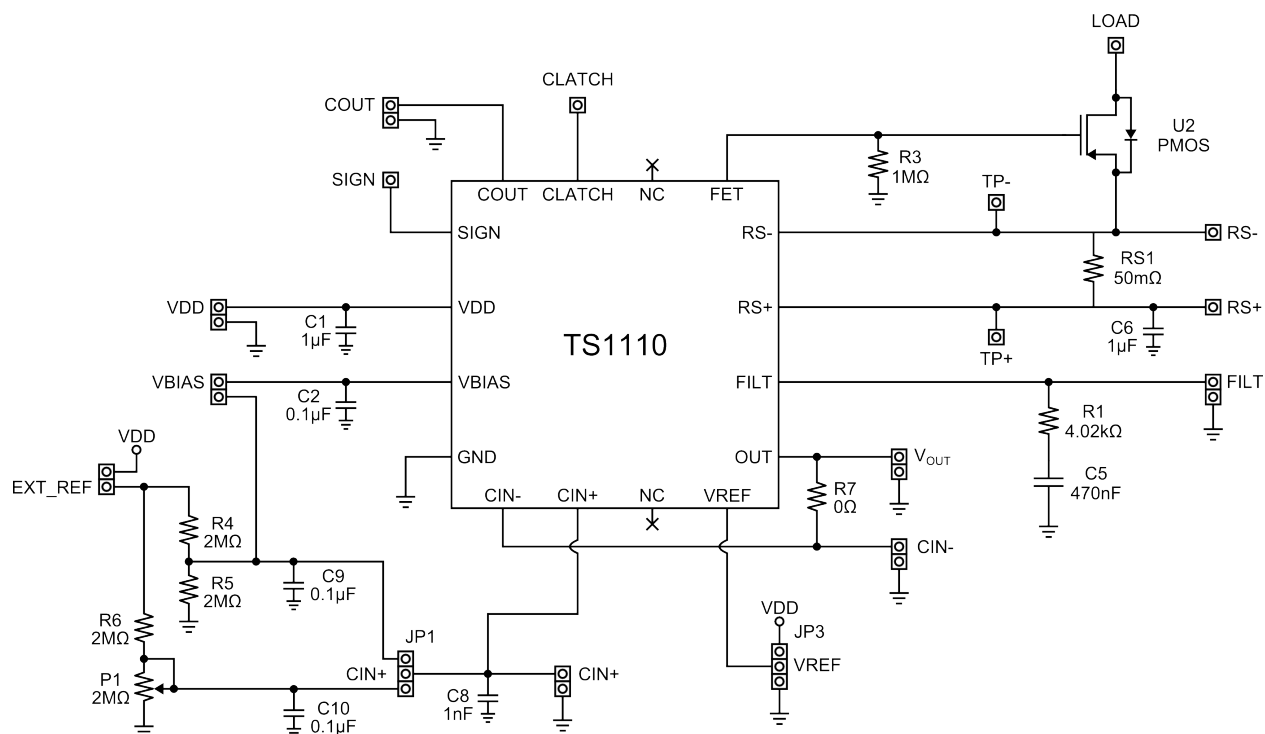

Figure 2.1. TS1110DB Circuit Schematic

### 3. TS1107-EVB Description

The TS1107 Evaluation Board is intended for evaluating the current limit detection feature of the TS1107. The evaluation board includes a variable reference scheme so that the threshold for the current limit comparator can be adjusted. The jumper, JP1, can be connected so that the included potentiometer can be used to adjust the threshold. When CLATCH is tied HIGH, the current limit comparator's output, COUT, indicates when the load has exceeded the current limit threshold and latches HIGH until the fault condition has been removed and the comparator has been reset. The Quick Start Procedure details two different load connections. The first load connection corresponds to a load under the current limiter's threshold, while the second load connection results in fault condition resulting in COUT latching HIGH.

**Table 3.1. Component List**

Designation	Quantity	Description
U1	1	TS1107-20, TS1107-200
RS1	1	50 mΩ ±0.5%, 1/2 W (1206)
C1, C6	2	1 μF ± 10%, 10 V (0603)
C2, C7, C9, C10	4	0.1 μF ± 10%, 10 V (0603)
C5	1	0.47 μF ± 10%, 10 V (0603)
C8	1	1 nF ± 10%, 25 V (0603)
R1	1	4.02 kΩ ± 1%, 1/16 W (0603)
R4, R5, R6	3	2 MΩ ± 1%, 1/10 W (0603)
R7	1	0 Ω, 1 A (0603)
J1, J2, J3, J4, J5, J6, J7	7	Header 1x1
JP1, JP3	2	Header 1x3
JP4, JP6, JP7, JP8, JP9, JP10, JP11, JP12	8	Jumper
JS1, JS4	2	Jumper Shunt

## 4. TS1107-EVB Quick Start Procedure

### Required Equipment

- 3 V Power Supply or 3 V Battery
- 2 Digital Multimeters
  - 1 ammeter
  - 1 voltmeter
- Potentiometer

To use the TS1107 evaluation board, perform the following steps:

1. Configure JP3 so that the Jumper Shunt is connecting VDD to VREF. Configure JP1 so that the Jumper Shunt is connecting CIN+ to the bottom header.
2. Connect a Jumper Shunt so that EXT\_REF is connected to VDD.
3. Connect CLATCH to GND.
4. Connect the 3 V power source to RS+ and VDD.
5. Use a voltmeter to measure the  $V_{BIAS}$  and the CIN+ voltage.  $V_{BIAS}$  should be 50% of VDD, 1.5 V. CIN+ should be 40% of VDD, 1.2 V. The P1 potentiometer can be adjusted so that the CIN+ voltage can be increased or decreased.
6. Once CIN+ and  $V_{BIAS}$  voltages are confirmed, connect CLATCH to VDD.
7. Connect a voltmeter to measure  $V_{OUT}$ . With no load connected  $V_{OUT}$  should be equal to  $V_{BIAS}$ . The expression for the  $V_{OUT}$  output voltage is defined by:

$$V_{OUT} = V_{BIAS} - (GAIN \times I_{SENSE} \times R_{SENSE})$$

8. Connect a voltmeter to measure COUT. COUT should be LOW.
9. Connect an ammeter in series from RS- to a potentiometer. Adjust the POT until the ammeter reads:
  - TS1107-20: 200 mA
  - TS1107-200: 20 mA

$V_{OUT}$  should equal 1.3 V and COUT should be LOW.

10. To enable the current limit detection, adjust the LOAD POT until the ammeter reads a value greater than:

- TS1107-20: 400 mA
- TS1107-200: 40 mA

$V_{OUT}$  should read 1.1 V, and COUT should latch HIGH detecting that the load current has exceeded the set current limit:

- TS1107-20 Current Limit: 300 mA
- TS1107-200 Current Limit: 30 mA

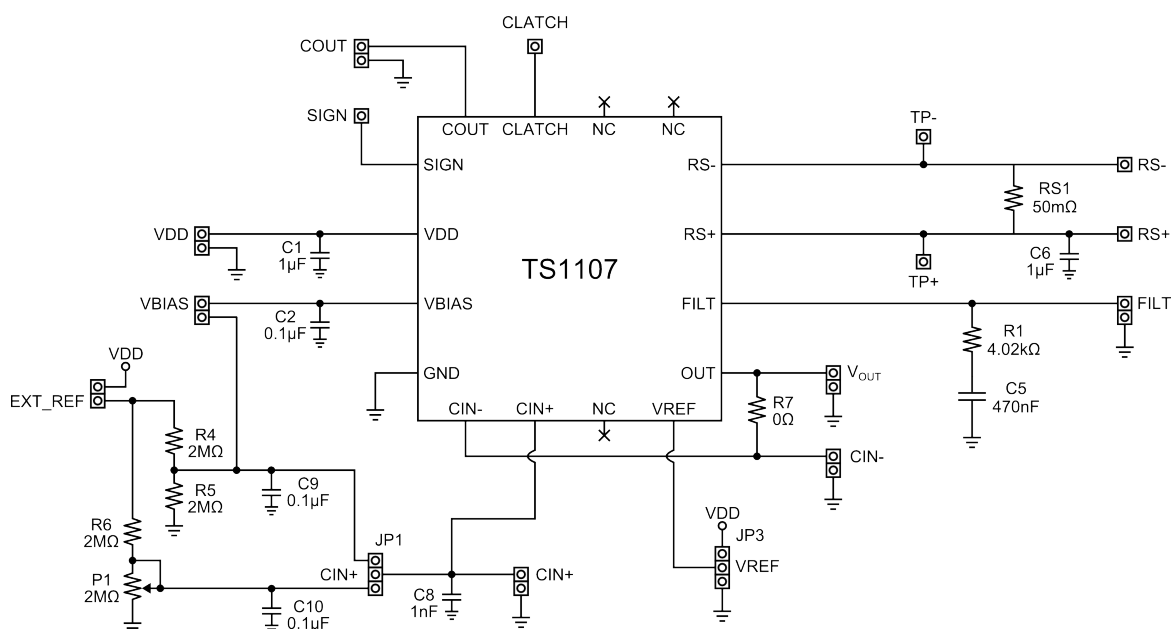
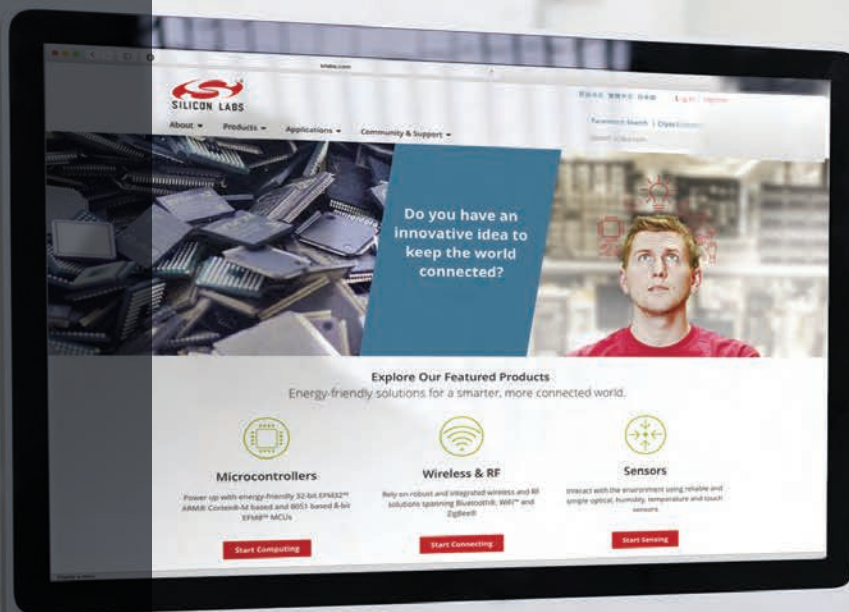

Figure 4.1. TS1107DB Circuit Schematic



Smart.  
Connected.  
Energy-Friendly



**Products**  
[www.silabs.com/products](http://www.silabs.com/products)



**Quality**  
[www.silabs.com/quality](http://www.silabs.com/quality)



**Support and Community**  
[community.silabs.com](http://community.silabs.com)

#### Disclaimer

Silicon Laboratories intends to provide customers with the latest, accurate, and in-depth documentation of all peripherals and modules available for system and software implementers using or intending to use the Silicon Laboratories products. Characterization data, available modules and peripherals, memory sizes and memory addresses refer to each specific device, and "Typical" parameters provided can and do vary in different applications. Application examples described herein are for illustrative purposes only. Silicon Laboratories reserves the right to make changes without further notice and limitation to product information, specifications, and descriptions herein, and does not give warranties as to the accuracy or completeness of the included information. Silicon Laboratories shall have no liability for the consequences of use of the information supplied herein. This document does not imply or express copyright licenses granted hereunder to design or fabricate any integrated circuits. The products must not be used within any Life Support System without the specific written consent of Silicon Laboratories. A "Life Support System" is any product or system intended to support or sustain life and/or health, which, if it fails, can be reasonably expected to result in significant personal injury or death. Silicon Laboratories products are generally not intended for military applications. Silicon Laboratories products shall under no circumstances be used in weapons of mass destruction including (but not limited to) nuclear, biological or chemical weapons, or missiles capable of delivering such weapons.

#### Trademark Information

Silicon Laboratories Inc., Silicon Laboratories, Silicon Labs, SiLabs and the Silicon Labs logo, CMEMS®, EFM, EFM32, EFR, Energy Micro, Energy Micro logo and combinations thereof, "the world's most energy friendly microcontrollers", Ember®, EZLink®, EZMac®, EZRadio®, EZRadioPRO®, DSPLL®, ISOmodem®, Precision32®, ProSLIC®, SiPHY®, USBXpress® and others are trademarks or registered trademarks of Silicon Laboratories Inc. ARM, CORTEX, Cortex-M3 and THUMB are trademarks or registered trademarks of ARM Holdings. Keil is a registered trademark of ARM Limited. All other products or brand names mentioned herein are trademarks of their respective holders.



Silicon Laboratories Inc.  
400 West Cesar Chavez  
Austin, TX 78701  
USA

<http://www.silabs.com>





Компания «ЭлектроПласт» предлагает заключение долгосрочных отношений при поставках импортных электронных компонентов на взаимовыгодных условиях!

Наши преимущества:

- Оперативные поставки широкого спектра электронных компонентов отечественного и импортного производства напрямую от производителей и с крупнейших мировых складов;
- Поставка более 17-ти миллионов наименований электронных компонентов;
- Поставка сложных, дефицитных, либо снятых с производства позиций;
- Оперативные сроки поставки под заказ (от 5 рабочих дней);
- Экспресс доставка в любую точку России;
- Техническая поддержка проекта, помощь в подборе аналогов, поставка прототипов;
- Система менеджмента качества сертифицирована по Международному стандарту ISO 9001;
- Лицензия ФСБ на осуществление работ с использованием сведений, составляющих государственную тайну;
- Поставка специализированных компонентов (Xilinx, Altera, Analog Devices, Intersil, Interpoint, Microsemi, Aeroflex, Peregrine, Syfer, Eurofarad, Texas Instrument, Miteq, Cobham, E2V, MA-COM, Hittite, Mini-Circuits, General Dynamics и др.);

Помимо этого, одним из направлений компании «ЭлектроПласт» является направление «Источники питания». Мы предлагаем Вам помощь Конструкторского отдела:

- Подбор оптимального решения, техническое обоснование при выборе компонента;
- Подбор аналогов;
- Консультации по применению компонента;
- Поставка образцов и прототипов;
- Техническая поддержка проекта;
- Защита от снятия компонента с производства.



#### Как с нами связаться

**Телефон:** 8 (812) 309 58 32 (многоканальный)

**Факс:** 8 (812) 320-02-42

**Электронная почта:** [org@eplast1.ru](mailto:org@eplast1.ru)

**Адрес:** 198099, г. Санкт-Петербург, ул. Калинина, дом 2, корпус 4, литера А.