

Features

- Simple drop in solution full GPS receiver
- MediaTek MT3337-E chip
- Ultra-small SMD package; 9.0 x 9.0 x 1.8mm
- Low current consumption
- AIC, Active Interference Cancellation
- EASY - Internally generated orbit prediction for fast fix times.

Description

A compact GPS module receiver using the MediaTek MT3337-E chip providing a complete GPS receiver for optimum performance. The M10578-A2 operates on a versatile 2.8V-4.2V supply with low power consumption and several low power modes for further power savings. An accurate 0.5ppm TXCO ensures short TTFF. Indoor and outdoor multi-path detection and compensation. A second stage LNA to ensure optimal performance making it suited for small wearable devices.

Applications

- Wearable devices
- Portable Devices
- Asset Tracking / Personal Safety
- Sport Cameras / Equipment
- Smart Watches
- Navigation devices

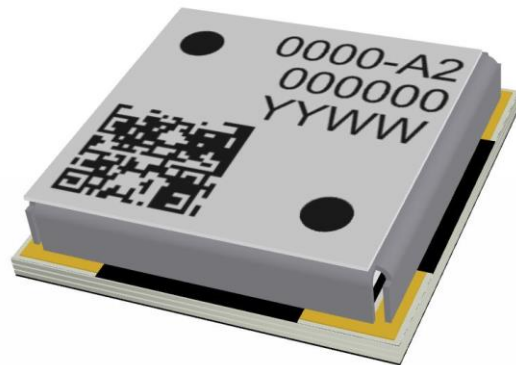

Part number

M10578-A2

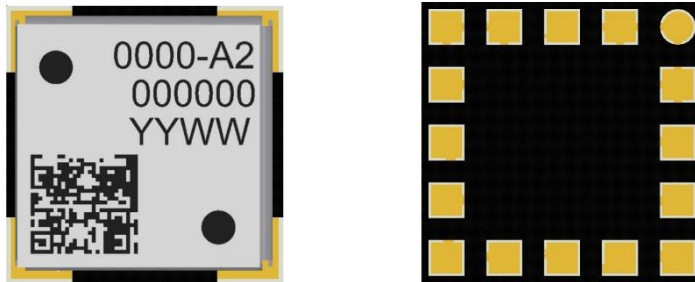

Functional Block Diagram

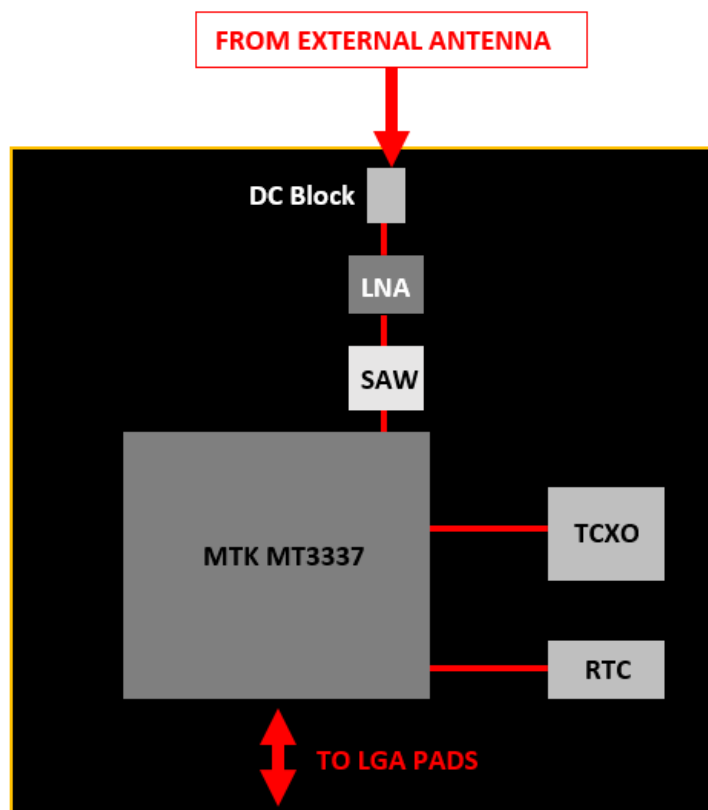

Module Specifications

Absolute Maximum Ratings

Symbol	Parameter	Min	Max	Unit
V_{CC}	Main Supply Voltage	-0.3	4.3	V
V_{IO}	Supply voltage I/O ring	-0.3	3.6	V
V_{BATT}	VBCKP Supply	-0.3	4.3	V
RF_{IN}	Maximum RF Input Power	N/A	+10	dBm
T_{STG}	Storage Temperature	-40	+85	°C
T_A	Operating Temperature	-40	+85	°C

* Exposure to absolute ratings may adversely affect reliability and may cause permanent damage.

Recommended Operating Conditions

Symbol	Parameter	Min	Typ	Max	Unit
V_{CC}	Main Supply Voltage	2.8	3.3	4.3	V
V_{BATT}	VBCKP Supply	2.8	3.3	4.3	V
T_{OP}	Operating Temperature	-40	-	+85	°C

DC Electrical Characteristics

Conditions: $V_{CC} = 3.3V$, $T_{OP} = 25\text{ °C}$

Symbol	Parameter	Typ	Unit
$I_{CC(PK)}$	Peak Acquisition Current	31	mA
$I_{CC(AVG)}$	Average Tracking Supply Current	24	mA
$I_{CC(STBY)}$	Standby (Sleep) Power Supply Mode	<200	μA
$I_{CC(BCKUP)}$	Backup Mode	<200	μA

RF Specifications

Conditions: $V_{CC} = 3.3V$, $T_{OP} = 25\text{ °C}$, Freq = 1575.420MHz

Symbol	Parameter	Typ	Unit
N_{LNA}^F	LNA Noise Figure (MT3337 Integral LNA)	2	dB
N_{LNA1st}^F	1 st Stage LNA	0.65	dB

Band Rejection

Frequency	Standard	Typ*	Unit
698-798	LTE700	43	dB
824-849	Cellular CDMA	43	dB
869-894	GSM850	43	dB
880-915	GSM900	43	dB
1710-1785	GSM1800/DCS	46	dB
1850-1910	GSM1900/PCS	50	dB
1920-1980	WCDMA	51	dB
2400-2492	WLAN, BT and WiMAX	57	dB
2500-2690	LTE2600	54	dB

*Does not include antenna rejection.

Mechanical Specifications

Parameter	Typ	Unit
Module exterior dimensions (L x W x H)	9.0 (±0.1) x 9.0 (±0.1) x 1.8 (+0.2 / - 0.0)	mm
Module support and connection	Surface mounted (SMD)	-
Module mass	<1	g

System Specifications

Communication	Specification
Data Output Protocol	NMEA 0183
Host Interfaces	UART
Default data rate on UART	4800/9600/38400/115200bps
GPS Engine	
Chip	MTK MT3337-E Chip
Channels	210 PRN / 66 Acquisition / 22 Tracking
TCXO	0.5ppm
Accuracy	
Horizontal Position Accuracy	<2.5m CEP
Maximum Position Update Rate	5 Hz
Sensitivity	
Acquisition (Cold)	-148dBm
Acquisition (Hot)	-163dBm
Tracking	-165dBm
TTF	
Hot Start	<1s
Warm Start	<25s (typical)
Cold Start	<35s (typical)
General	
Maximum Altitude	<18.000 km
Maximum Speed	<514 m/s
Active Interference Cancellers	12 multi tone active cancellers ISSCC2011 award
Additional Features	1PPS Sync
EPO / EASY	Orbit prediction

50% CEP, Open-Sky, 24hr Static, -130dBm, good view of the sky

Pin out Description

Table shows the designation and function of each pin on the M10578-A2 module.

Pin	Designator	Description
1	GND	Ground connection
2	GND	Ground connection
3	RF_IN	RF connection from antenna (50Ω)
4	GND	Ground connection
5	GND	Ground connection
6	1PPS	Pulse Per Second Output
7	HW_R	System reset, active low
8	HW_S	Used to enable standby mode. If not used leave floating.
9	RX	UART Receive data line
10	TX	UART Transmit data line
11	E2	Hardware Baud rate select
12	E3	Hardware Baud rate select
13	FIX	Indicates once a GPS fix has been obtained.
14	BV	Backup Voltage +2.0V to 4.2V
15	VCC	Main DC supply, +2.8 to +4.2V
16	GND	Ground connection

Schematic symbol of module

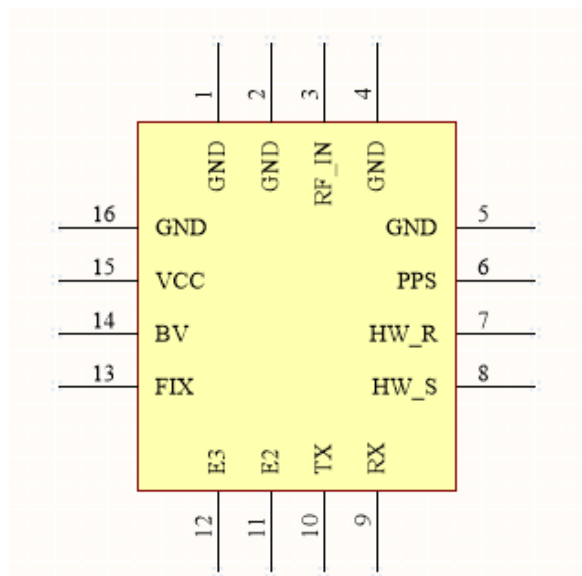

Mechanical

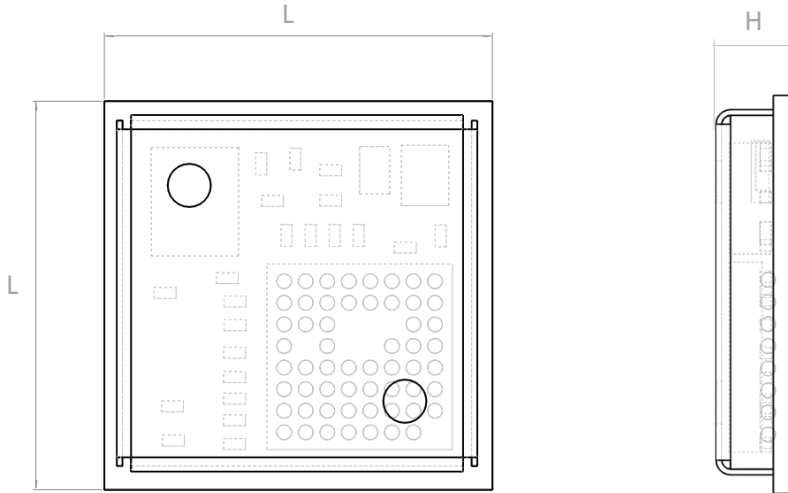

All dimensions in mm

L	H
Length	Height
9.0 ±0.1	1.8 +0.2 / - 0.0

Module Footprint

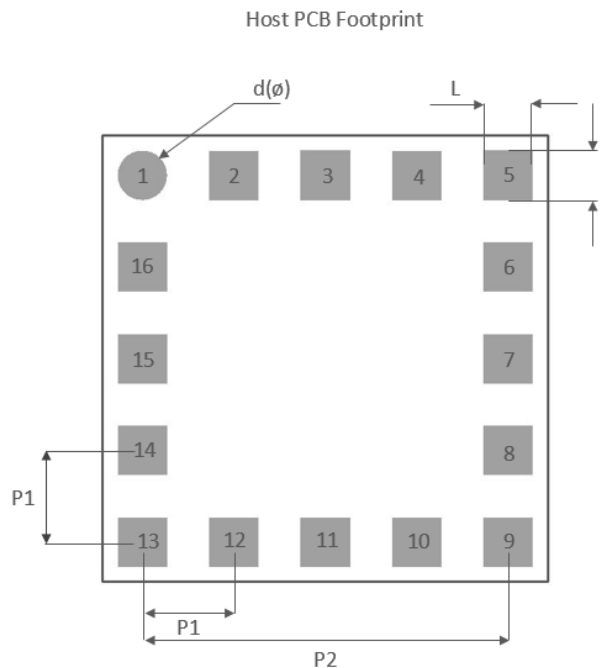

L	P1	P2	d(∅)
Pad Size	Pad pitch	Pitch total	Diameter pad 1
1.0	1.85	7.40	1.0

All dimensions in mm

Application Schematic Example for M10578-A2:

The circuit below shows a basic design for use with the UART interface and configuring the default baud rate to 9600.

Baud Rate = 9600 (Hardware configured)

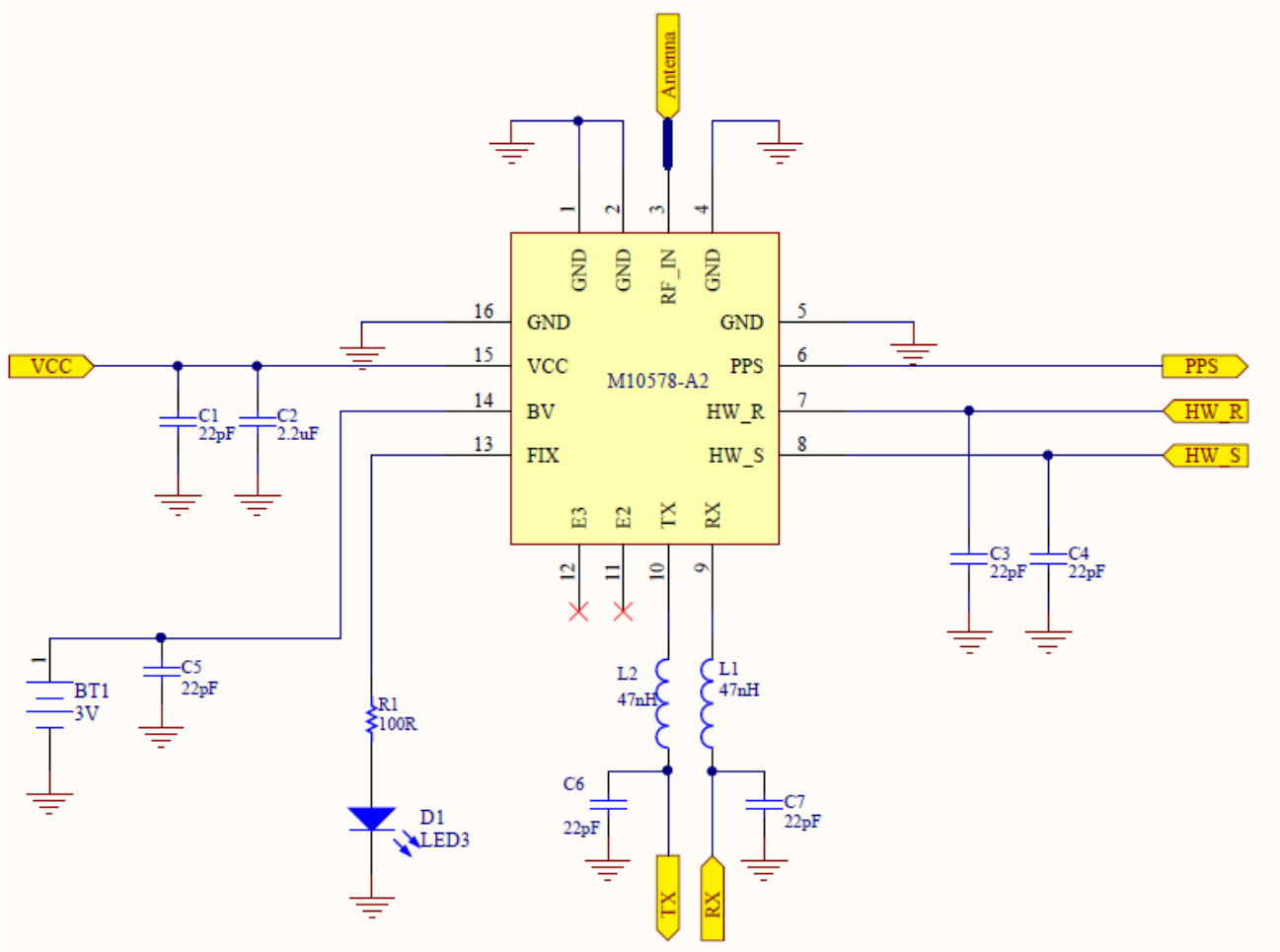

Bill of Material

Designator	Value	Description/Comments	Quantity
C1, C3, C4, C5, C6, C7	22pF capacitor	Decoupling cap. Place close to corresponding pin	6
C2	2.2uF capacitor	Decoupling cap. Place close to corresponding pin	1
L1, L2	47nH Inductor	Filter component	2
BT1	3V Battery	3.0Volt Battery cell for battery backup	1
D1	LED	Illuminates when GPS fix	1
R1	Resistor	For LED drive	1

Host Baud Rate/Protocol Selection

The modules default baud rate is user configurable at start-up with a hardware configuration. This is limited to the values in the following table.

The baud rate and output protocol can be changed dynamically after start up using the relevant commands. Please contact Antenova for more information about protocol messages.

Hardware Baud Rate Selection Table

Baud Rate	Pin11 (E2)	Pin 12 (E3)
9600	NC	NC
115200	NC	PD
4800	PD	NC
38400	PD	PD

NC = Not connected. Leave floating
 PD = Pull down resistor to GND (10K Ω)

Host Interface

UART Interface

The UART converts bytes of data to and from asynchronous start -stop bit streams as binary electrical impulses. The port contains a 16-byte FIFO, and 256 bytes of URAM. The bit rates are selectable from 4800, 9600, 38400 and 115200 bps.

The IO level from the UART port are CMOS compatible, however for RS232 compatibility the use of external level shifters will be required. The hardware configuration of the port baud can be changed dynamically by the use of commands. These will be active and saved as long as the VBACKP supply is applied.

The default protocol is determined by hardware configuration.

Power Supply

The M10578-A2 uses two DC supply inputs. VBCKUP to power the RAM and RTC sections of the receiver, and VCC to power the digital and processing sections. VBCKUP is to be applied all the time to keep these sections alive. VCC can be removed to initiate a backup power save mode (See page 9). VBCKUP can be removed if a battery is also used at VBCKUP to maintain this supply. The supply is internally regulated for 2.8V meaning the external supply is versatile for a range of voltage levels.

TM (1PPS)

TM is a one pulse per second output from the receiver providing uses for timing purposes. The pulse is not only limited to being active every second, but also allows the setup to a required duration, frequency and active high/low by programming user defined settings.

PPS Sync NMEA

The latency range of the beginning of UART Tx is between 170ms and 180ms and behind the rising edge of the PPS.

- 1Hz NMEA output and baud rate at between 14400 – 115200
- Enable this function using PMTK255 (Default off)

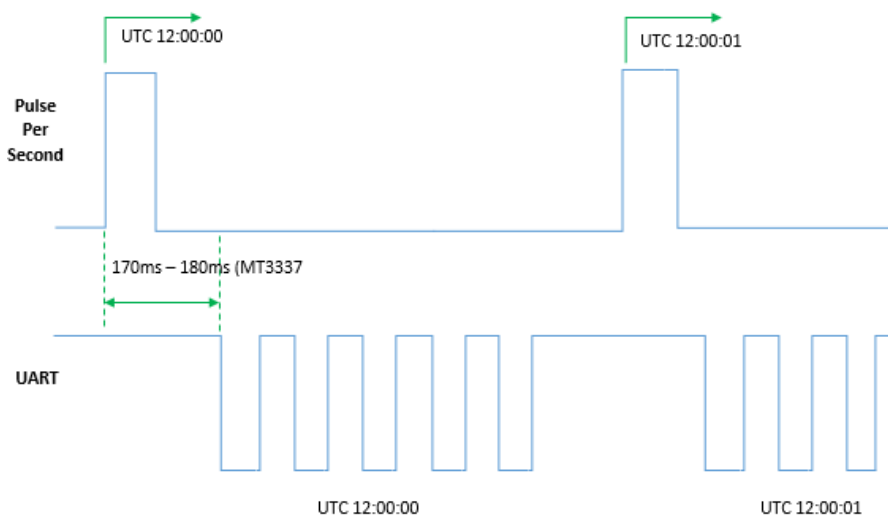

HRST (Hardware Reset Pin)

The External reset pin is default high by an internal 75Kohm and should be left floating if not used. To initiate a reset the pin needs to be pulled low. The module also initiates a reset if the VCC drops below the minimum 2.8V supply.

Power Management

The M10578-A2 has three power saving modes.

- Standby mode
- Back up mode
- Periodic mode

Standby Mode

Standby mode is a power saving mode that shuts down the RF section of the module and puts the processor into a standby mode. The RTC is kept alive and the RAM power is maintained to keep the module configuration.

The standby state can be initiated either with a hardware signal to Pin26 or by using a command.

Hardware controlled Standby:

Enable standby mode by a low state to pin 8 (HW_S). To wake the module back to full power a high state needs to be applied to pin 8. If Pin 8 is not to be used then it must be kept floating (not connected).

Standby mode command:

Software on the host needs to send the "PMTK161 command through the UART interface.

Command	M10578-A2 standby then wakeup	Current consumption (Typ)
\$PMTK161,0*28	M10578-A2 enters standby mode	<200uA
Any byte	M10578-A2 wakes up from standby mode	

Back up mode

To enter backup mode the VCC simply needs to be removed. Once initiated the RTC and all configuration is saved along with any ephemeris data to allow quick TTFF once the VCC is re-applied. VBACKUP needs to be applied at all times for backup mode to run correctly.

Periodic mode

Periodic mode is a module controlled mode that reduces current consumption by only waking the module for short periods to maintain fix data. The periodic state is user configured. Contact Antenna for more information and a user command manual.

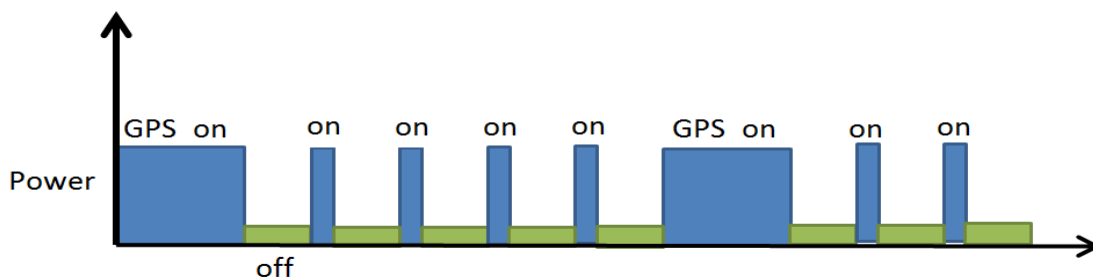

PMTK225 setting	M10578-A2 time off/awake	Current usage (Typ)
PMTK225, 2,3000,18000,72000	Module sleeps for 12secs, then wakes for 3secs Periodically. 72000 is for a cold boot condition.	<200uA

EPO (Extended Prediction Orbit) data service

The EPO allows the use of up to a 30-day orbit predictions that can be used to aid the module for an instant fix solution

- A proxy server on the customer’s side to update EPO files from the MTK server daily.
- Application software to access the proxy server through the internet (optional if host device can access internet)
- Software on host device to send EPO data to M10578-A2 module to allow instant fix by using

EE data. Please contact Antenova for more information. Requires permission from MTK to use service.

EASY (Self-Generated Orbit prediction)

The module supports EASY™ (Embedded Assisted System) is a Self-Generated Orbit Prediction feature. It provides up to 3 days GPS orbit prediction ability without the need for any host CPU porting or internet connection requirements.

EASY works as embedded software which accelerates TTFF by predicting satellite navigation messages from received ephemeris. EASY is a fully automated receiver task that is efficiently scheduled and computed in free time of every second after a GNSS navigation solution.

EASY is default off and can be enabled by a PMTK command.

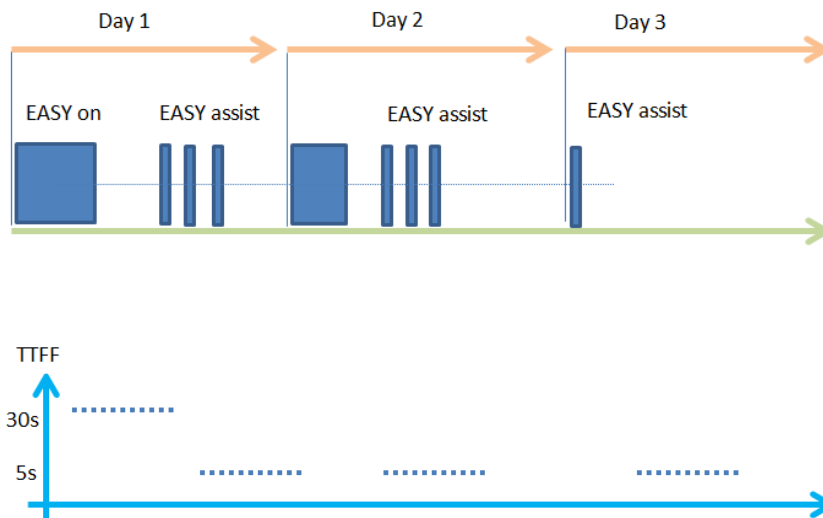

AIC (Active Interference Cancellation)

The AIC feature provides effective narrow-band interference and jamming elimination. The GPS signal can be recovered from the jammed signal and allows users to obtain better navigation quality. This can be beneficial since many of today’s devices have more and more functionality with regards to transmitters with many on-board antennas

Front-end Rejection

The figure below shows the rejection for the input SAW filter after the 1st stage LNA, including the effect of pads, tracks. The plot can be useful to calculate the isolation required from adjacent transmitters in order to avoid the saturation of the LNA.

Input SAW Rejection – Wideband

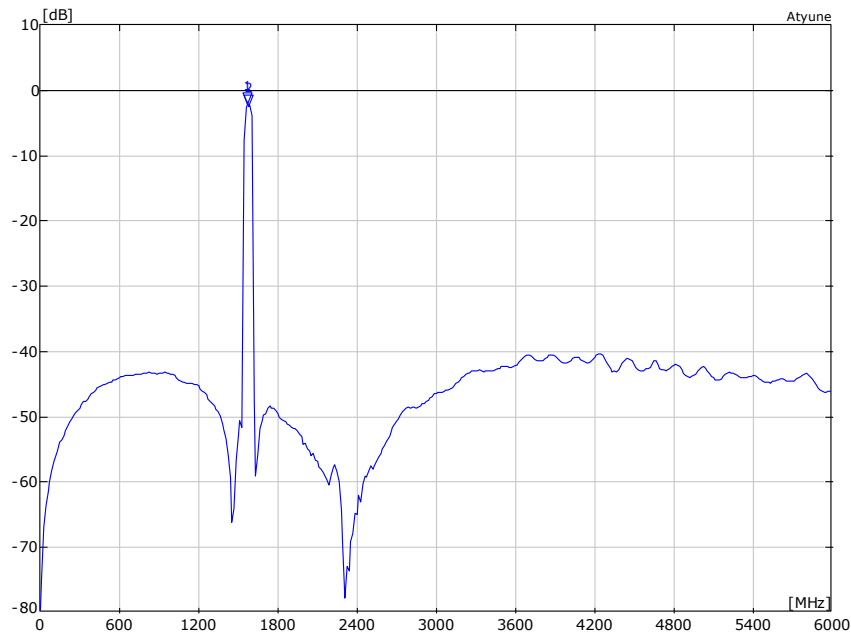

Input SAW Rejection - Narrowband

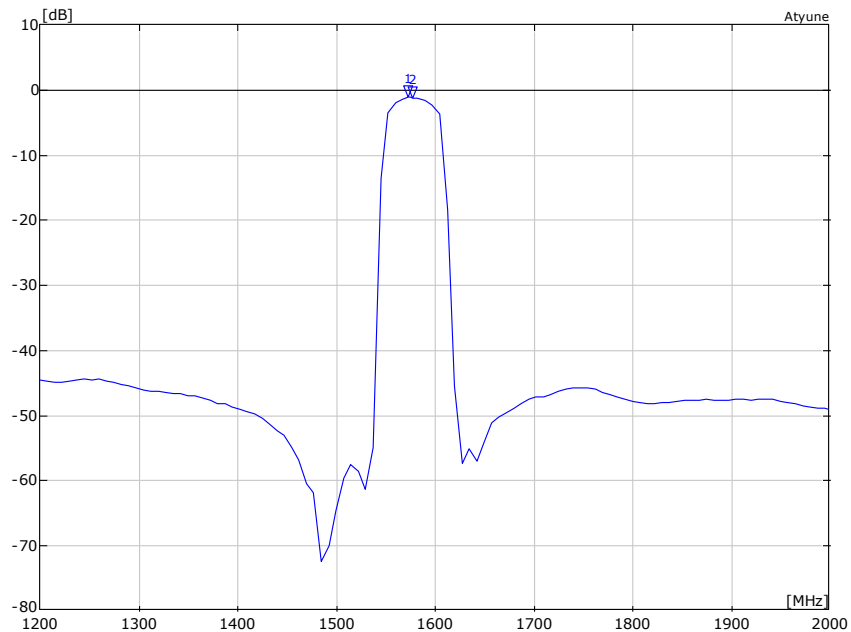

Evaluation Kit

The EVK is a single PCB that contains the module and required components to run on a PC via a USB cable and Antenova software. Evaluation kits are available on request. Please contact Antenova for more information.

M10578-A2-U1

Top Side

Bottom Side

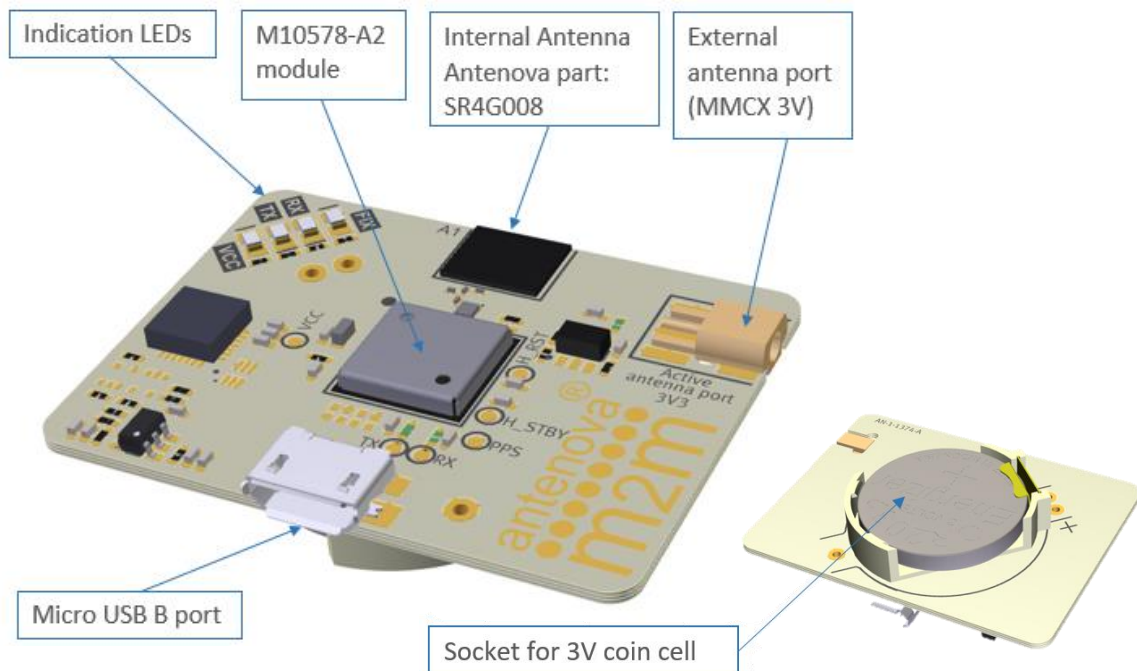
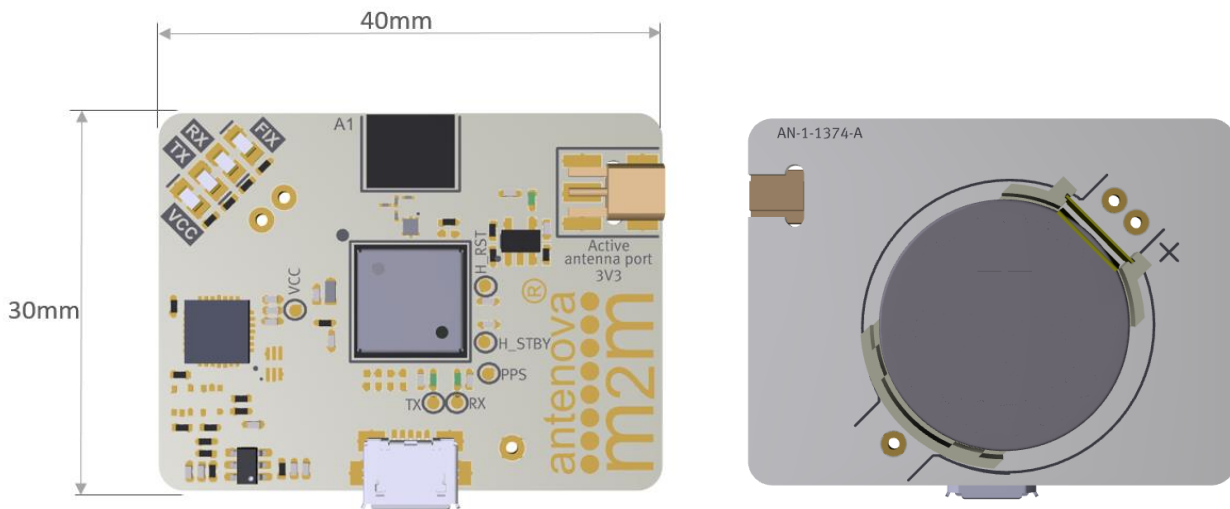

Reflow Soldering

Placement

Typical placement systems used for any BGA/LGA package are acceptable. Recommended nozzle diameter for placement: 5mm

Soldering Paste

Use of “No Clean” soldering paste is strongly recommended, as it does not require cleaning after the soldering process has taken place. An example of suitable soldering paste is Alpha OM350.

Soldering

The recommended soldering profile for M10578-A2 is shown below. However, it is the responsibility of the Contract Manufacturer to determine the exact reflow profile used, taking into consideration the parameters of the host PCB, solder paste used, etc.

Profile Feature		Pb-Free Solder
Pre-Heat	Temperature (T_s) Min	130°C
	Temperature (T_s) Max	220°C
	Time (t_s)	<150s
Reflow	Liquidus Temperature - (T_l)	220°C
	Time (t_l)	45-90s
Peak Package Body Temperature (T_p)		245°C
Time within 5°C of peak temp (t_p)		30s
Average Ramp up rate - $T_s(\text{max})$ to (T_p)		3°C/s
Ramp Down Rate		6°C/s max

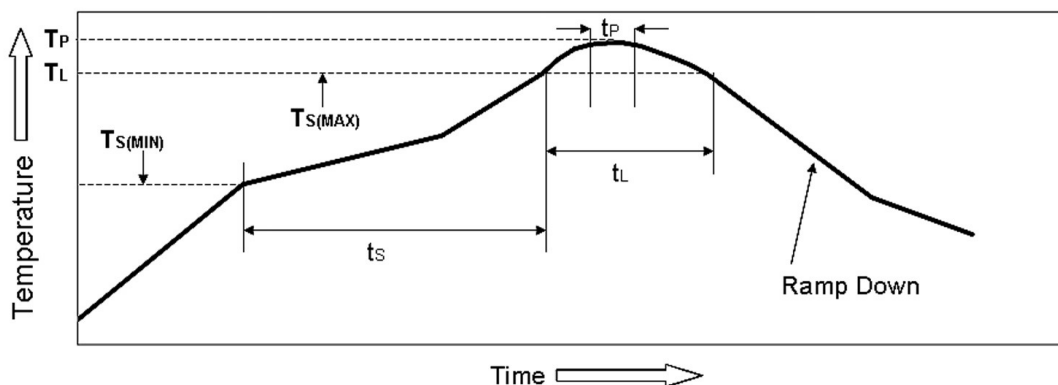

Example Reflow profile

The Pb Free Process-Package Peak Reflow Temperature is 260°C.

Exceeding the maximum soldering temperature could permanently damage the module.

Multiple Soldering

The M10578-A2 module can be submitted up to 2 reflow soldering processes.

Upside-down soldering is acceptable but it is recommended that the Contract Manufacturer qualify the process before mass production. The second reflow must take place within the recommended floor life limit (MSL3). Please contact Antenova for further information.

Hand Soldering

Hand-soldering and rework of the M10578-A2 module is acceptable, however care must be taken to avoid short circuits due to the small size of the module pads.

Quality and Environmental Specifications

Test	Standard	Parameters
PCB Inspection	IPC-6012B, Class 2. Qualification and Performance Specification for Rigid Printed Boards - Jan 2007	
Assembly Inspection	IPC-A-610-D, Class 2 "Acceptability of electronic assemblies"	
Temperature Range	ETSI EN 300 019-2-7 specification T 7.3	-30 °C, +25 °C, +85 °C, operating
Damp Heat	ETSI EN 300 019-2-7 specification T 7.3	+70 °C, 80% RH, 96 hrs, non-operating
Thermal Shock	ETSI EN 300 019-2-7 specification T 7.3 E	-40 °C ... +85 °C, 200 cycles
Vibration	ISO16750-3	Random vibration, 10~1000Hz, 27.8m/s ² , 8hrs/axis, X, Y, Z 8hrs for each 3 axis non-operating
Shock	ISO16750-3	Half-sinusoidal 50g, 6ms, 10time/face, ±X, ±Y and ±Z non-operating
Free Fall	ISO16750-3	1m height, 2 drops on opposite side
ESD Sensitivity	JEDEC, JESD22-A114 ESD Sensitivity Testing Human Body Model (HBM), Class 2 JEDEC, JESD22-A115 ESD Sensitivity Testing Machine Model (MM), Class B	+2000V - Human hand assembly +200V - Machine automatic final assembly
Shear	IEC 60068-2-21, Test Ue3: Shear	Force of 5N applied to the side of the PCB
Moisture/Reflow Sensitivity	IPC/JEDEC J-STD-020D.1	MSL3
Storage (Dry Pack)	IPC/JEDEC J-STD-033C	MSL3
Solderability	EN/IEC 60068-2-58 Test Td	More than 90% of the electrode should be covered by solder. Solder temperature 245 °C ± 5 °C

Moisture Sensitivity

Antenova ships all devices dry packed in tape on reel with desiccant and moisture level indicator sealed in an airtight package. If on receiving the goods the moisture indicator is pink in colour or a puncture of the airtight seal packaging is observed, then follow J-STD-033 "Handling and Use of Moisture/Reflow Sensitive Surface Mount Devices".

Storage (Out of Bag)

The M10578-A2 modules meet MSL Level 3 of the JEDEC specification J-STD-020D - 168 hours Floor Life (out of bag) ≤30 °C/60% RH. If the stated floor life expires prior to reflow process then follow J-STD-033 "Handling and Use of Moisture/Reflow Sensitive Surface Mount Devices".

Hazardous material regulation conformance

The RF antenna module meets RoHS requirements.

Packaging

Tape Characteristics

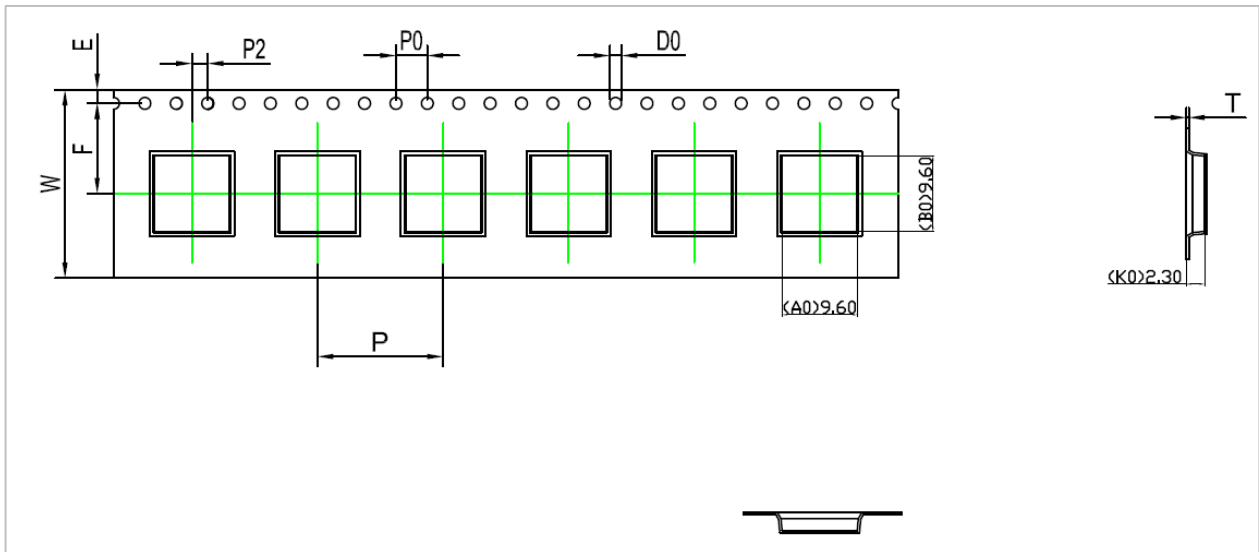

W	F	E	P0	P	P2
24.00 ±0.3	11.50 ±0.1	1.75 ±0.1	4.00 ±0.1	16 ±0.1	2.00 ±0.1
D0	B0	T	K0	A0	
1.55 ±0.1	9.60 ±0.1	0.30 ±0.05	2.30 ±0.1	9.60 ±0.1	

Dimensions in mm

Quantity	Leading Space	Trailing Space
1000 pcs / reel	50 blank module holders	50 blank module holders

Reel Dimensions

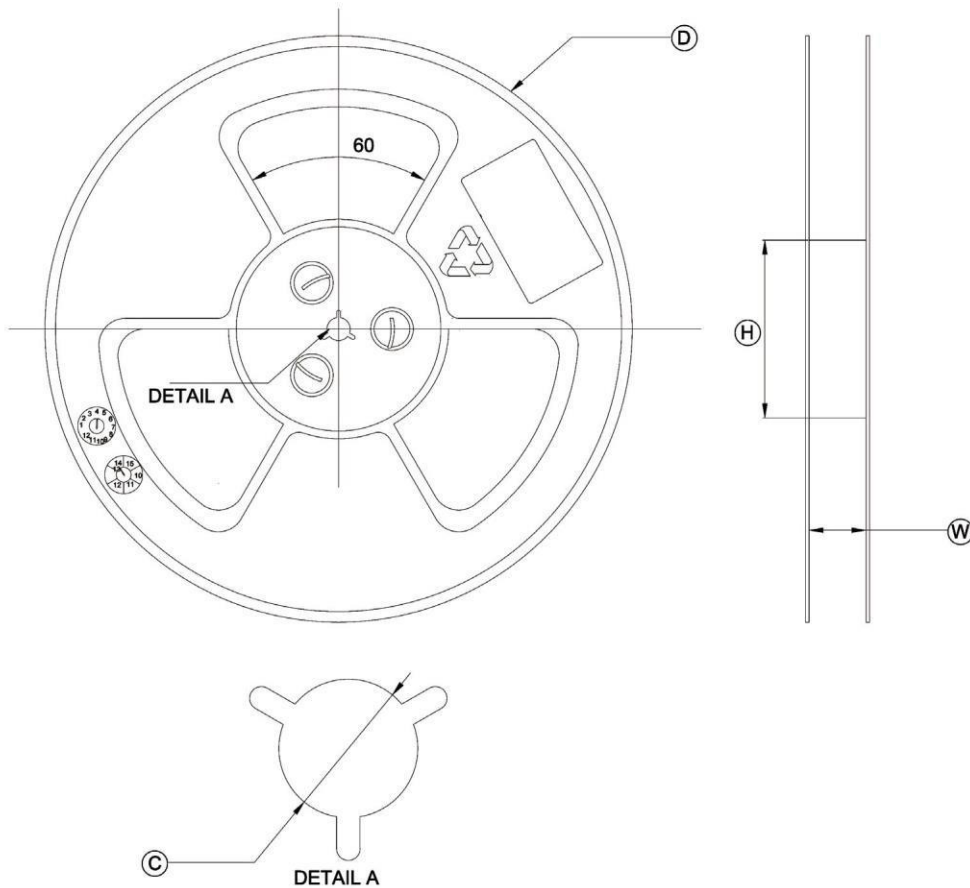

Width (W)	Reel Diameter (D)	Hub Diameter (H)	Shaft Diameter (C)
24.4mm +0.2/-0.2	330.0mm +0.0/-2.0	100.0mm +3.0/-3.0	13.3mm +0.3/-0.3



www.antenova-m2m.com

Corporate Headquarters

Antenova Ltd.
2nd Floor, Titan Court,
3 Bishop Square,
Hatfield, AL10 9NA
UK

Tel: +44 (0) 1223 810600
Email: sales@antenova-m2m.com

USA Headquarters

Antenova USA
100 Brush Creek Road, Suite 103,
Santa Rosa,
CA 95404
USA

Tel: +1 (707) 890 5202
Email: sales@antenova-m2m.com

Asia Headquarters

Antenova Asia Ltd.
4F, No. 324, Sec. 1, Nei-Hu Road
Nei-Hu District
Taipei 11493
Taiwan, ROC

Tel: +886 (0) 2 8797 8630
Fax: +886 (0) 2 8797 6890
Email: sales@antenova-m2m.com

Copyright® Antenova Ltd. All Rights Reserved. Antenova®, Antenova M2M, RADIONOVA® and the Antenova and Antenova M2M logos are trademarks and/or registered trademarks of Antenova Ltd. Any other names and/or trademarks belong to their respective companies.

The materials provided herein are believed to be reliable and correct at the time of print. Antenova does not warrant the accuracy or completeness of the information, text, graphics or other items contained within these information. Antenova further assumes no responsibility for the use of this information, and all such information shall be entirely at the user's risk.



Certificate No: 4598

Antennas for Wireless M2M Applications

20



Компания «ЭлектроПласт» предлагает заключение долгосрочных отношений при поставках импортных электронных компонентов на взаимовыгодных условиях!

Наши преимущества:

- Оперативные поставки широкого спектра электронных компонентов отечественного и импортного производства напрямую от производителей и с крупнейших мировых складов;
- Поставка более 17-ти миллионов наименований электронных компонентов;
- Поставка сложных, дефицитных, либо снятых с производства позиций;
- Оперативные сроки поставки под заказ (от 5 рабочих дней);
- Экспресс доставка в любую точку России;
- Техническая поддержка проекта, помощь в подборе аналогов, поставка прототипов;
- Система менеджмента качества сертифицирована по Международному стандарту ISO 9001;
- Лицензия ФСБ на осуществление работ с использованием сведений, составляющих государственную тайну;
- Поставка специализированных компонентов (Xilinx, Altera, Analog Devices, Intersil, Interpoint, Microsemi, Aeroflex, Peregrine, Syfer, Eurofarad, Texas Instrument, Miteq, Cobham, E2V, MA-COM, Hittite, Mini-Circuits, General Dynamics и др.);

Помимо этого, одним из направлений компании «ЭлектроПласт» является направление «Источники питания». Мы предлагаем Вам помощь Конструкторского отдела:

- Подбор оптимального решения, техническое обоснование при выборе компонента;
- Подбор аналогов;
- Консультации по применению компонента;
- Поставка образцов и прототипов;
- Техническая поддержка проекта;
- Защита от снятия компонента с производства.



Как с нами связаться

Телефон: 8 (812) 309 58 32 (многоканальный)

Факс: 8 (812) 320-02-42

Электронная почта: org@eplast1.ru

Адрес: 198099, г. Санкт-Петербург, ул. Калинина, дом 2, корпус 4, литера А.