

PI6C5912016

16 Output LVPECL Fanout Buffer

Features

- 16 differential LVPECL outputs
- 2 selectable reference inputs support either single-ended or differential
- Up to 2GHz output frequency
- Ultra low additive phase jitter: < 0.01 ps (typ) (differential 156.25MHz, 12KHz to 20MHz integration range)
- Low skew between outputs
- Low delay from input to output (Tpd typ. < 1.7ns)
- Separate Input output supply voltage for level shifting
- 2.5V / 3.3V power supply
- Industrial temperature support
- Package: TQFN-48

Description

The PI6C5912016 is a high performance LVPECL fanout buffer device which supports up to 2GHz frequency. This device is ideal for systems that need to distribute low jitter LVPECL clock signals to multiple destinations.

Applications

- Networking systems including switches and routers
- High frequency backplane based computing and telecom platforms

Block Diagram

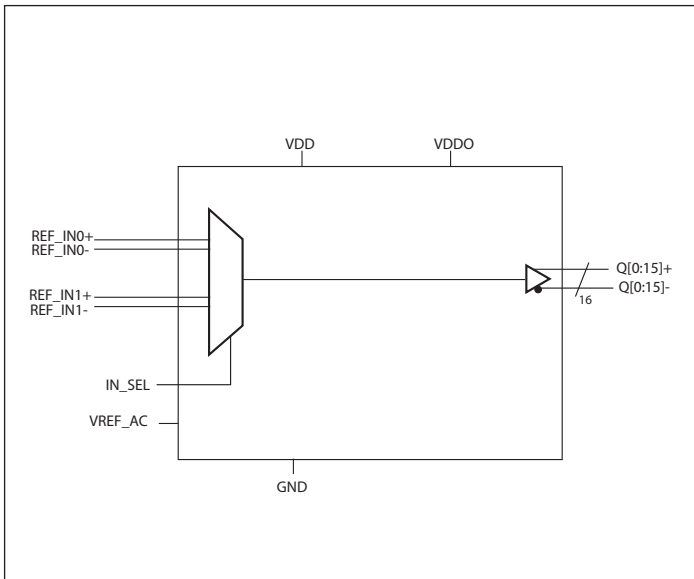

Pin Configuration

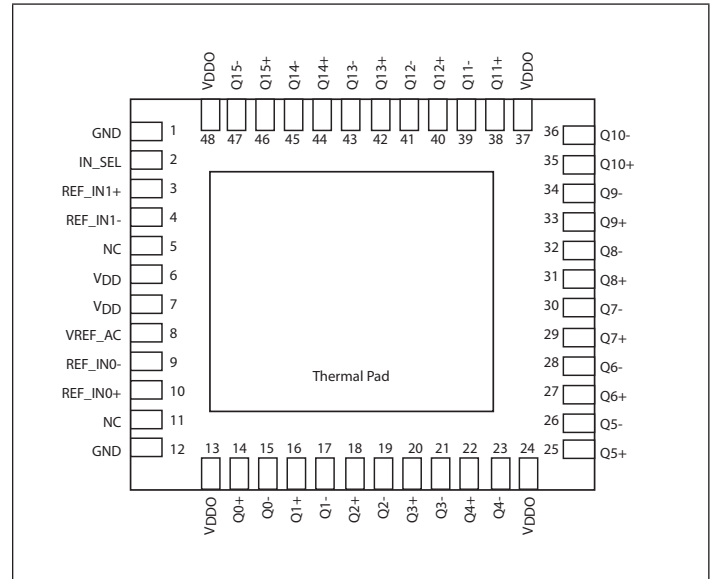

Pin Description

Pin #	Pin Name	Type		Description
1, 12	GND	Power		Power supply ground
2	IN_SEL	Input	Pulldown	Input clock select. See Table 1 for function. LVCMOS/LVTTL interface levels.
3, 4	REF_IN1+ REF_IN1-	Input		Reference input 1. Accepts Differential or Single Ended inputs
5, 11	NC	-		No Connect
6, 7	VDD	Power		Core power supply
8	VREF_AC	Output		Bias voltage output.
9, 10	REF_IN0+ REF_IN0-	Input		Reference input 0. Accepts Differential or Single Ended inputs
13, 24, 37, 48	VDDO	Power		Output power supply
14, 15	Q0+ Q0-	Output		LVPECL output pair 0.
16, 17	Q1+ Q1-	Output		LVPECL output pair 1.
18, 19	Q2+ Q2-	Output		LVPECL output pair 2.
20, 21	Q3+ Q3-	Output		LVPECL output pair 3.
22, 23	Q4+ Q4-	Output		LVPECL output pair 4.
25, 26	Q5+ Q5-	Output		LVPECL output pair 5.
27, 28	Q6+ Q6-	Output		LVPECL output pair 6.
29, 30	Q7+ Q7-	Output		LVPECL output pair 7.
31, 32	Q8+ Q8-	Output		LVPECL output pair 8.
33, 34	Q9+ Q9-	Output		LVPECL output pair 9.
35, 36	Q10+ Q10-	Output		LVPECL output pair 10.

Pin Description Cont.

Pin #	Pin Name	Type	Description
38, 39	Q11+	Output	LVPECL output pair 11.
	Q11-		
40, 41	Q12+	Output	LVPECL output pair 12.
	Q12-		
42, 43	Q13+	Output	LVPECL output pair 13.
	Q13-		
44, 45	Q14+	Output	LVPECL output pair 14.
	Q14-		
46, 47	Q15+	Output	LVPECL output pair 15.
	Q15-		
Thermal pad	-	-	Thermal pad. Connect to ground.

Function Table

Table 1: Input select function

IN_SEL	Function
0	REF_IN0 is the selected reference input
1	REF_IN1 is the selected reference input
Open	No inputs selected. Outputs Hi-Z

Symbol	Parameter	Test Condition	Min.	Typ.	Max.	Units
C_{IN}	Input Capacitance			2		pF
$R_{PULLDOWN}$	Input Pulldown Resistor			200		k Ω
R_{PULLUP}	Input Pullup Resistor			200		k Ω

Maximum Ratings (Above which the useful life may be impaired. For user guidelines, not tested)

Storage temperature.....	-55 to +150°C
Supply Voltage to Ground Potential (V_{DD}, V_{DDO})...	-0.5 to +4.6V
Inputs (Referenced to GND)	-0.5 to $V_{DD}+0.5V$
Clock Output (Referenced to GND).....	-0.5 to $V_{DD}+0.5V$
Latch up	200mA
ESD Protection (Input)	2000 V min (HBM)
ESD Protection (Input)	1000 V min (CDM)

Note:

Stresses greater than those listed under MAXIMUM RATINGS may cause permanent damage to the device. This is a stress rating only and functional operation of the device at these or any other conditions above those indicated in the operational sections of this specification is not implied. Exposure to absolute maximum rating conditions for extended periods may affect reliability.

Power Supply Characteristics and Operating Conditions

Symbol	Parameter	Test Condition	Min.	Typ.	Max.	Units
V_{DD}	Core Supply Voltage		3.135	3.3	3.465	V
			2.375	2.5	2.625	V
V_{DDO}	Output Supply Voltage		3.135	3.3	3.465	V
			2.375	2.5	2.625	V
I_{EE}	Supply Internal Current			127	146	mA
I_{DD}	Core Power Supply Current			91	105	
T_A	Ambient Operating Temperature		-40		85	°C

DC Electrical Specifications - Differential Inputs

Symbol	Parameter	Test Condition	Min.	Typ.	Max.	Units
I_{IH}	Input High current	Input = V_{DD}			20	uA
I_{IL}	Input Low current	Input = GND	-20			uA
V_{IH}	Input high voltage				$V_{DD}+0.3$	V
V_{IL}	Input low voltage		-0.3			V
V_{ID}	Input Differential Amplitude PK-PK		0.1			V
V_{CM}	Common mode input voltage		GND + 0.5		$V_{DD}-0.85$	V
ISO_{MUX}	MUX isolation			-89		dBc

DC Electrical Specifications - LVCMOS Inputs

Symbol	Parameter	Conditions	Min.	Typ.	Max.	Units
I_{IH}	Input High current	Input = V_{DD}			50	μA
I_{IL}	Input Low current	Input = GND	-50			μA
V_{IH}	Input high voltage	$V_{DD}=3.3V$	2.0		$V_{DD}+0.3$	V
V_{IL}	Input low voltage	$V_{DD}=3.3V$	-0.3		0.8	V
V_{IH}	Input high voltage	$V_{DD}=2.5V$	1.7		$V_{DD}+0.3$	V
V_{IL}	Input low voltage	$V_{DD}=2.5V$	-0.3		0.7	V

DC Electrical Specifications- LVPECL Outputs

Parameter	Description	Conditions	Min.	Typ.	Max.	Units
V_{OH}	Output High voltage		$V_{DDO}-1.4$		$V_{DDO}-0.9$	V
V_{OL}	Output Low voltage	$V_{DD}=2.5V$	$V_{DDO}-1.9$		$V_{DDO}-1.25$	V
		$V_{DD}=3.3V$	$V_{DDO}-2.2$		$V_{DDO}-1.25$	V

AC Electrical Specifications – Differential Inputs

Parameter	Description	Conditions	Min.	Typ.	Max.	Units
F_{IN}	Clock input frequency				2000	MHz
V_{INPP}	Differential Input peak to peak voltage	$1.5GHz \leq F_{IN} \leq 2 GHz$	0.2		1.5	V
		$F_{IN} \leq 1.5 GHz$	0.1		1.5	V
ER	Input Edge Rate		1.5			V/ns

AC Electrical Specifications – LVCMOS Inputs

Parameter	Description	Conditions	Min.	Typ.	Max.	Units
F_{IN}	Clock input frequency	REF_IN0+, REF_IN1+			200	MHz
V_{INPP}	LVCMOS Input peak to peak voltage		0.8		VDD	V
ER	Input Edge Rate		1.5			V/ns

AC Electrical Specifications – LVPECL Outputs

Parameter	Description	Conditions	Min.	Typ.	Max.	Units
F _{OUT}	Clock output frequency	LVPECL			2000	MHz
T _r	Output rise time	From 20% to 80%		150		ps
T _f	Output fall time	From 80% to 20%		150		ps
T _{ODC}	Output duty cycle		48		52	%
V _{PP}	Output swing Single-ended	@1GHz to ≤2GHz	250		850	mV
		@ ≤1GHz	500		950	mV
T _j	Buffer additive jitter RMS	156.25MHz, 12kHz to 20MHz		0.04	0.08	ps
		156.25MHz, 10kHz to 1MHz		0.03	0.08	ps
T _{SK}	Output Skew			13	30	ps
T _{PD}	Propagation Delay			620	700	ps
T _{OD}	Valid to HiZ				100	ns
T _{OE}	HiZ to valid				100	ns
T _{P2P Skew}	Part to Part Skew ¹		-50		50	ps
V _{REF_AC}	Input bias voltage	I _{AC} = 2mA	V _{DD} -1.6		V _{DD} -1.1	V

Propagation Delay

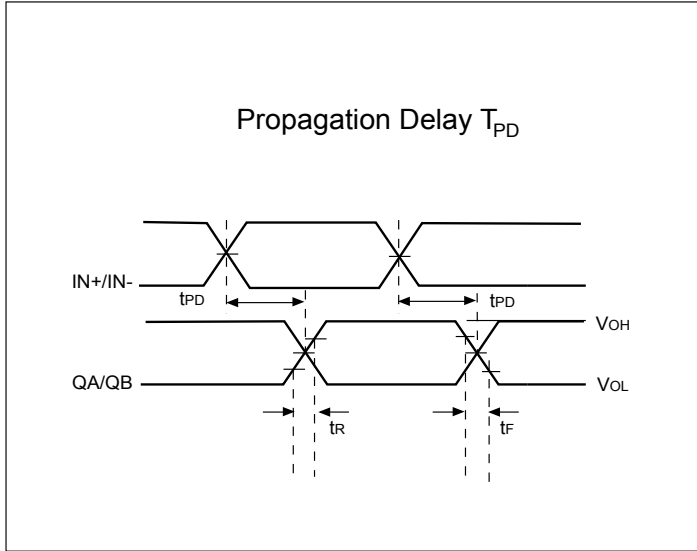

Output Skew

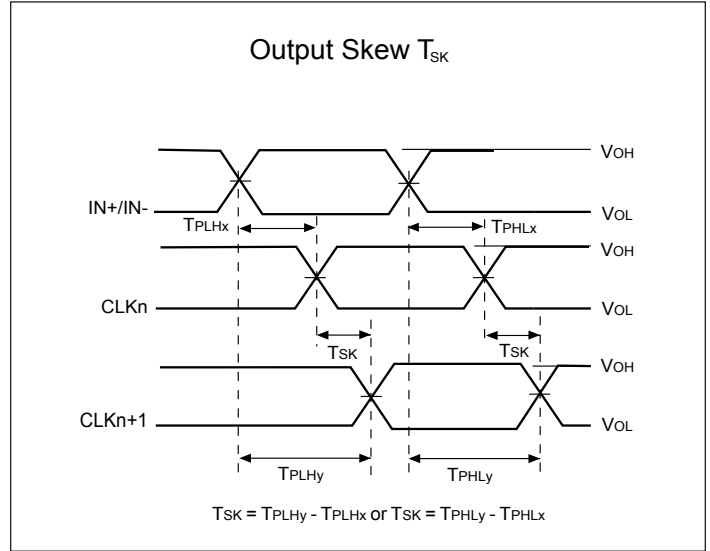

Part to Part Skew

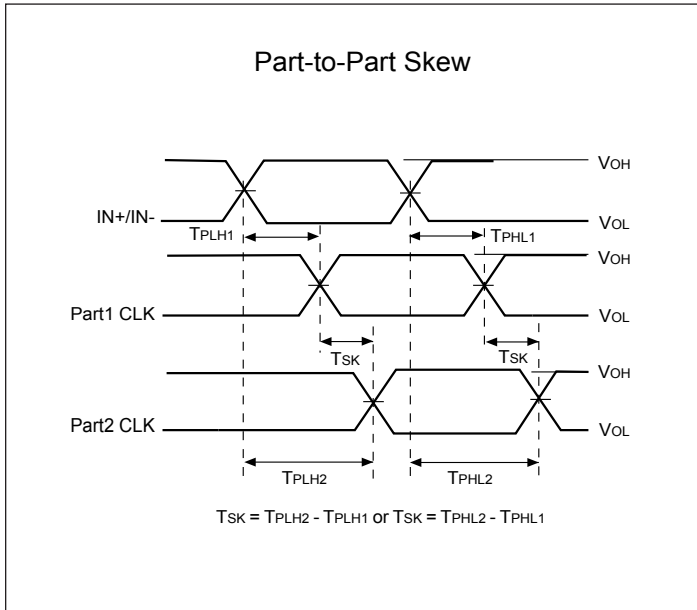

LVPECL Output Swing vs. Frequency

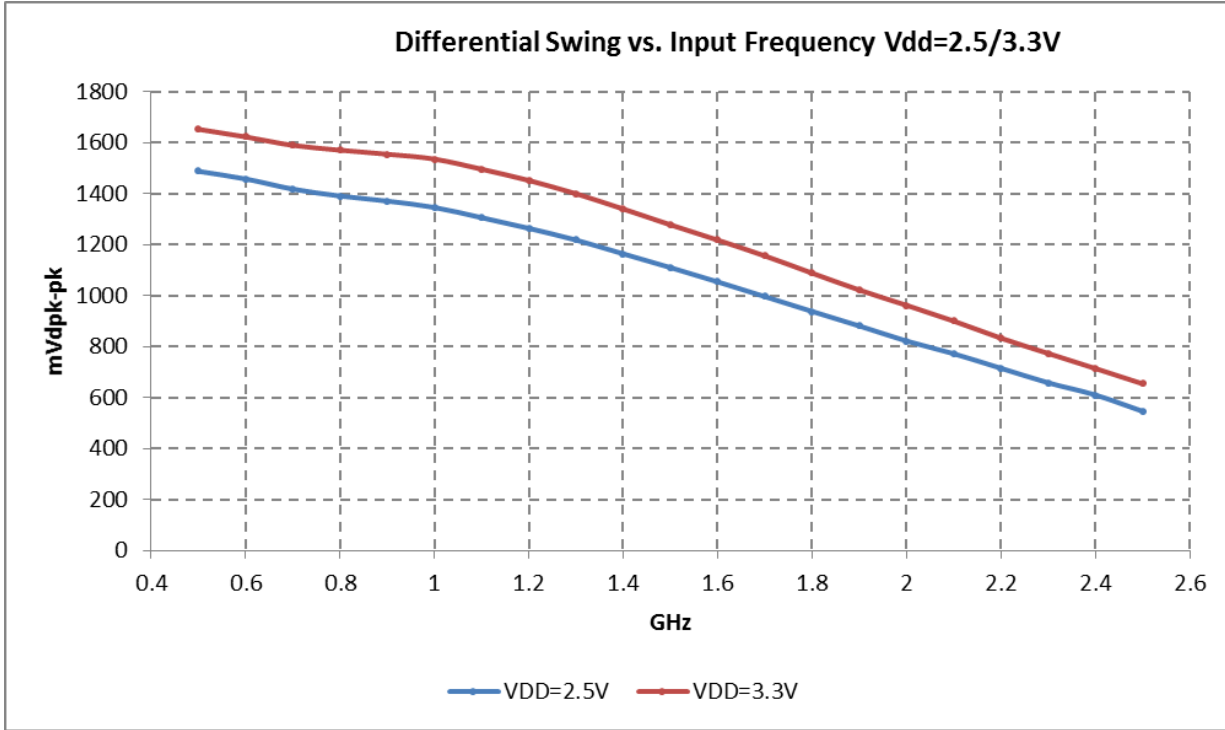

Phase Noise and Additive Jitter

Output phase noise (Dark Blue) vs Input Phase noise (light blue)

$$\text{Additive jitter} = \sqrt{(\text{Output jitter}^2 - \text{Input jitter}^2)}$$

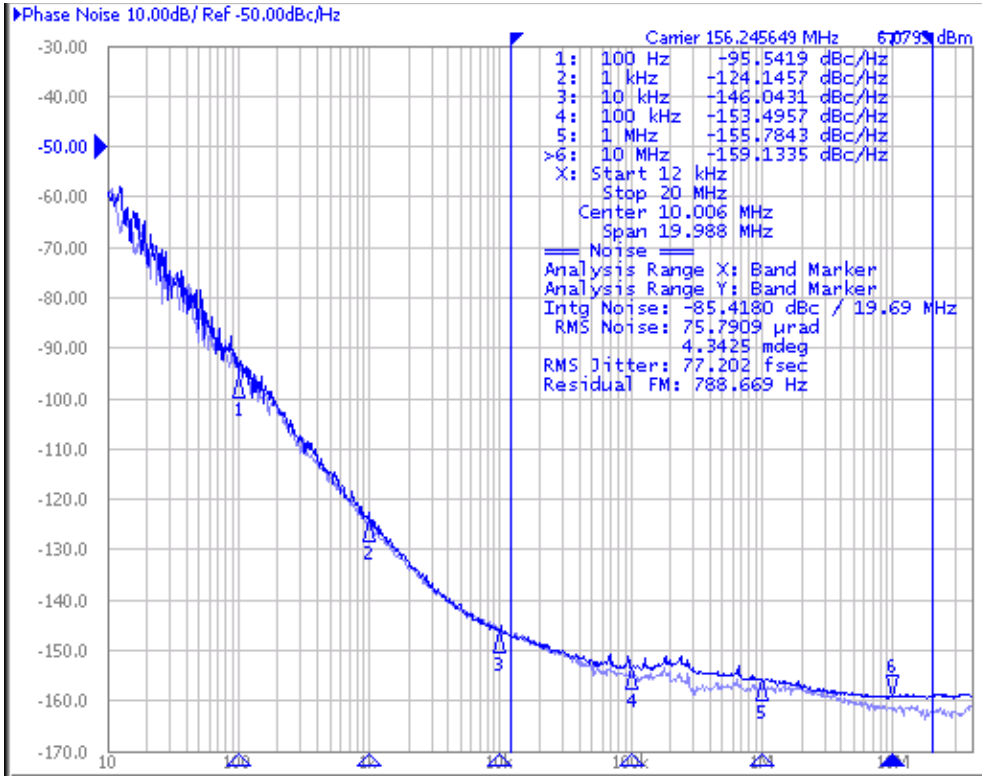

Configuration Test Load Board Termination for LVPECL Outputs

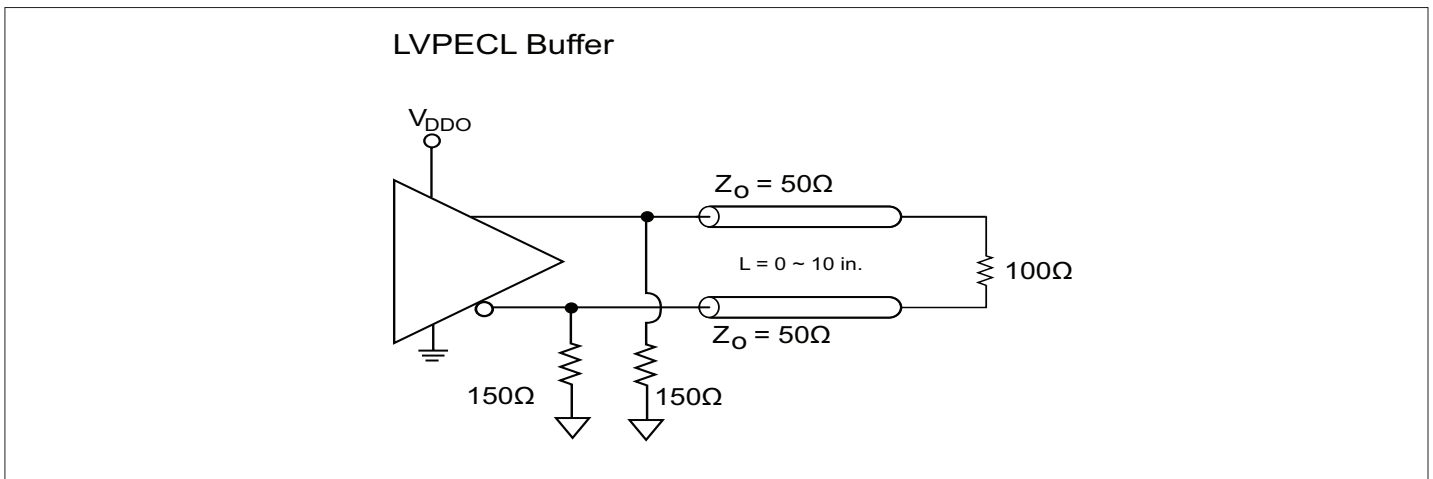

Power Supply Filtering Techniques

As in any high speed analog circuitry, the power supply pins are vulnerable to random noise. To achieve optimum jitter performance, power supply isolation is required. All power pins should be individually connected to the power supply plane through vias, and 0.1 μ F and 1 μ F bypass capacitors should be used for each pin.

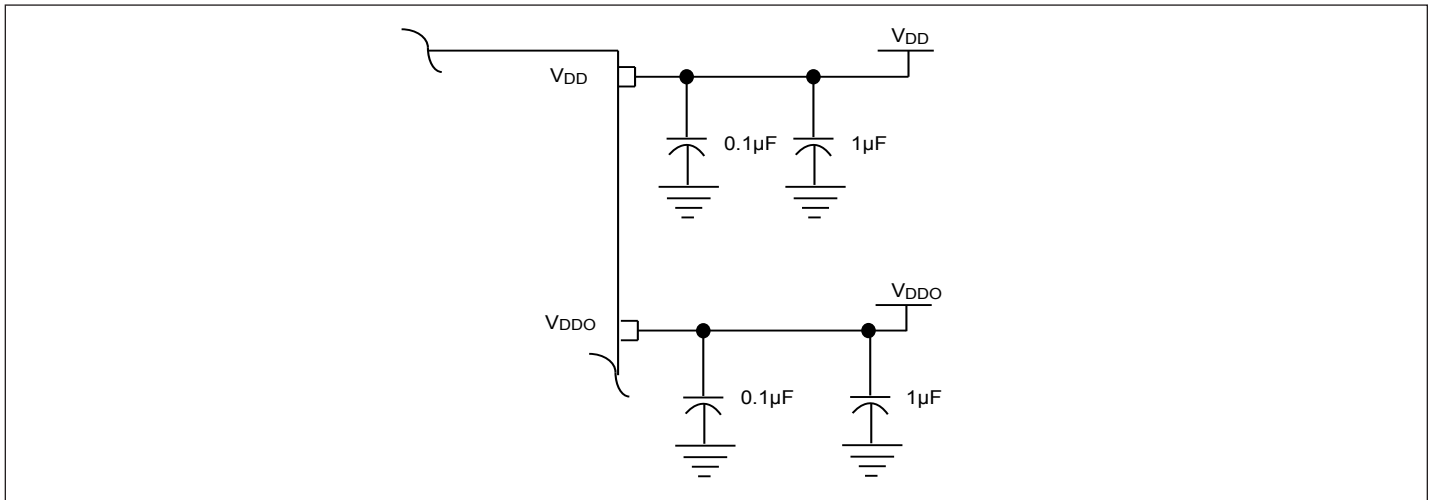

Single Ended Input, AC couple

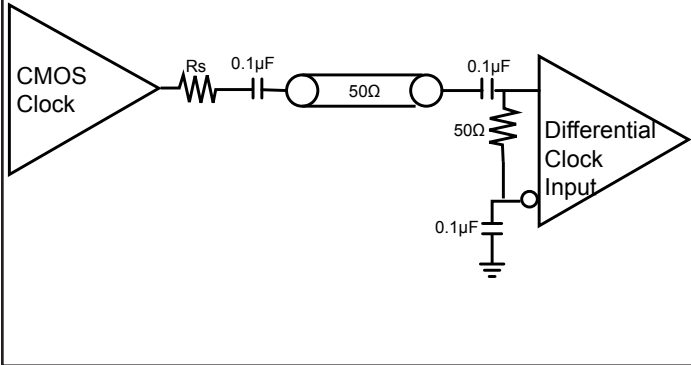

Single Ended Input, DC couple

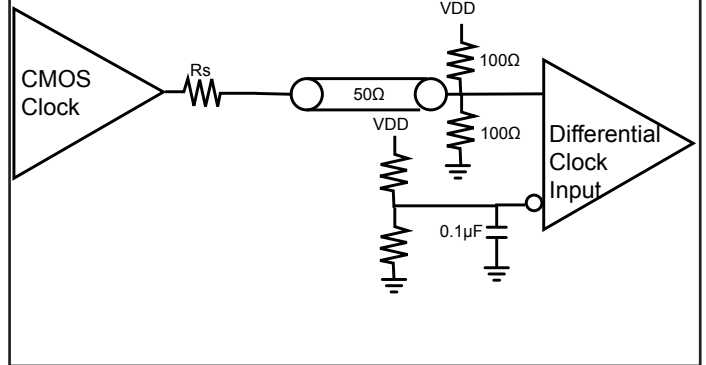

Single Ended Input, DC couple

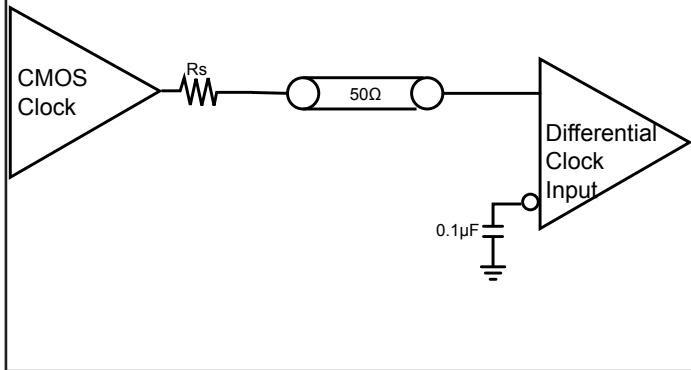

LVPECL/ LVDS AC and DC input

*Remove for LVDS

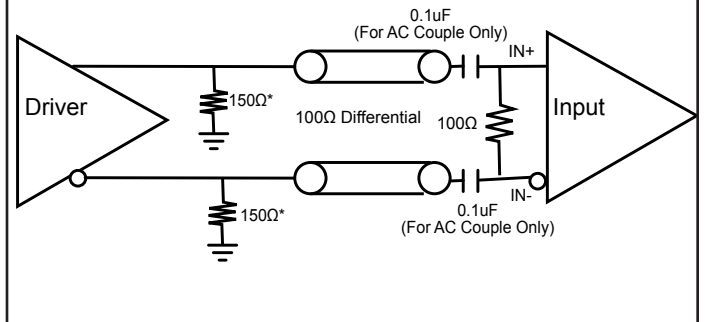

LVPECL, AC Couple, Thevenin Equivalent

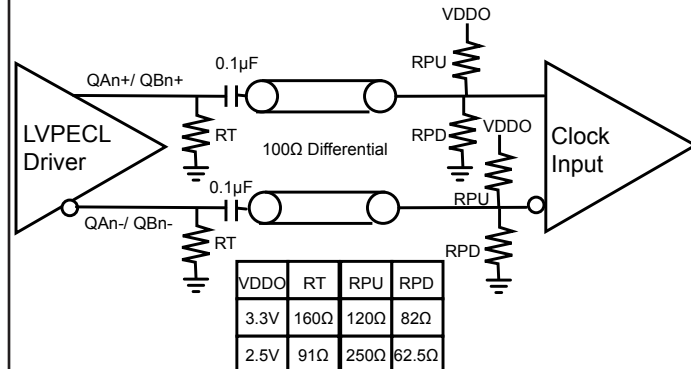

LVPECL, DC Couple, Thevenin Equivalent

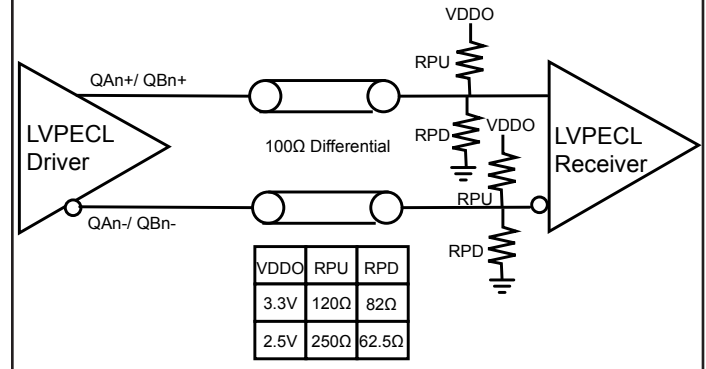

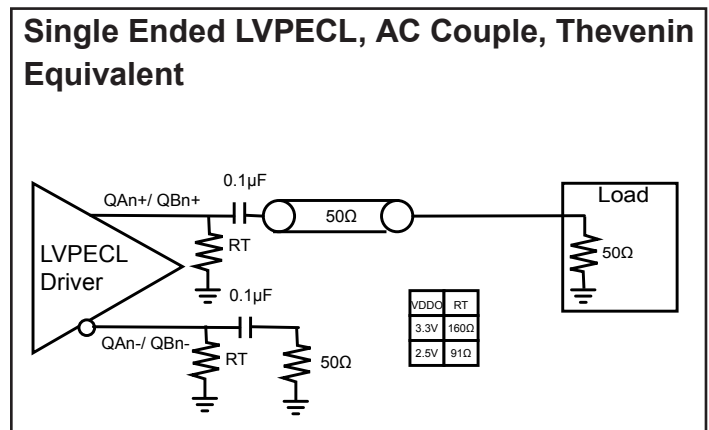
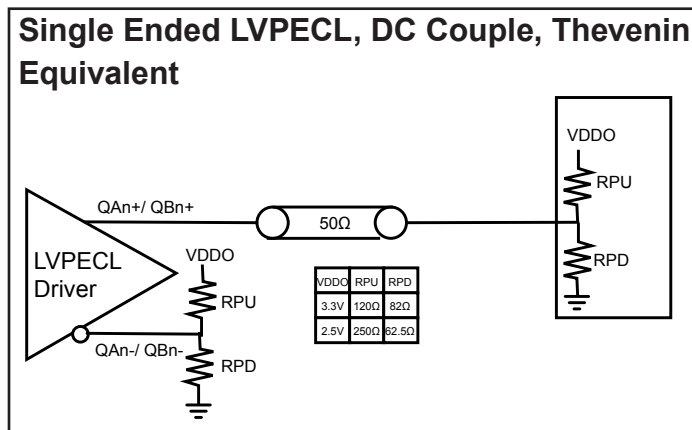
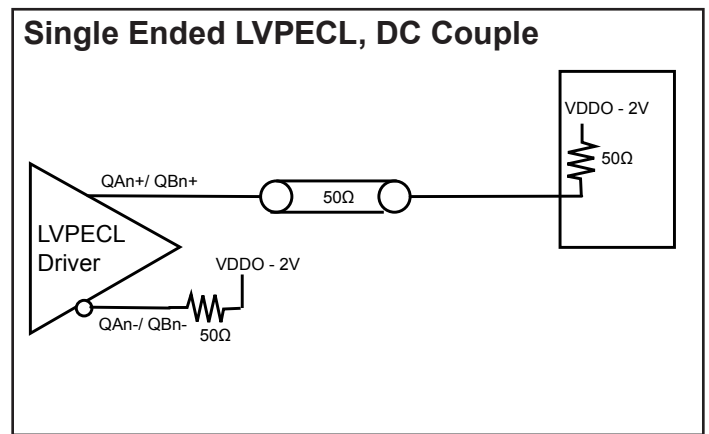
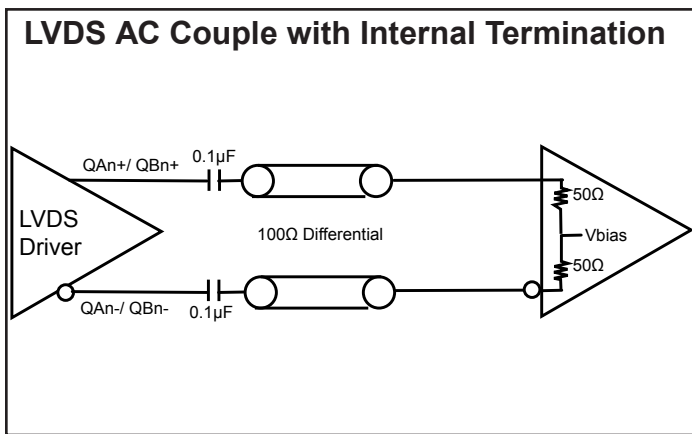
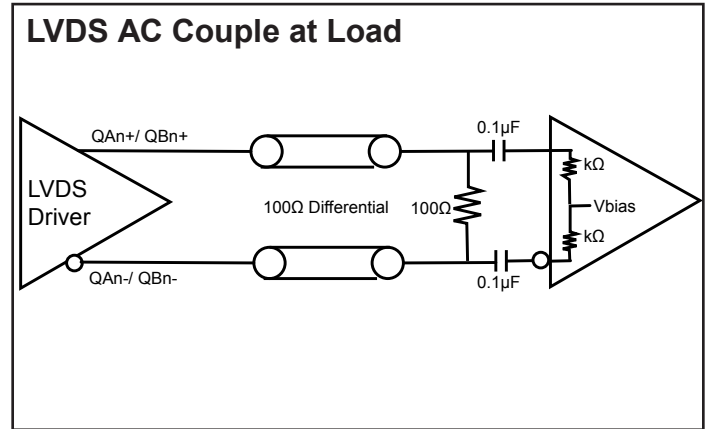
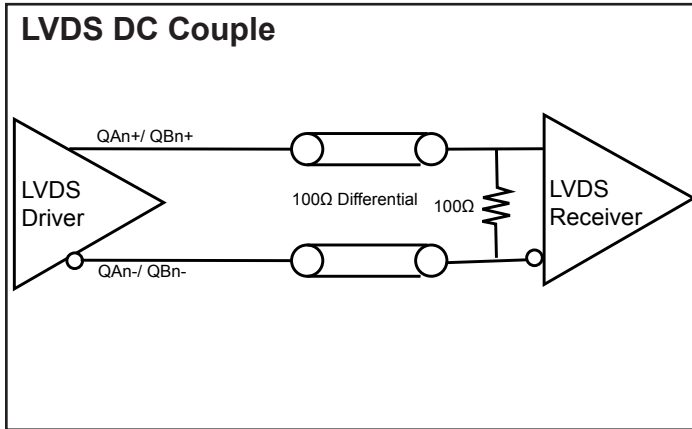

Thermal Information

Symbol	Description	Condition	
Θ_{JA}	Junction-to-ambient thermal resistance	Still air	23.65 °C/W
Θ_{JC}	Junction-to-case thermal resistance		9.10 °C/W

Part Marking

Top mark not available at this time. To obtain advance information regarding the top mark, please contact your local sales representative.

Packaging Mechanical: 48-TQFN (ZD)

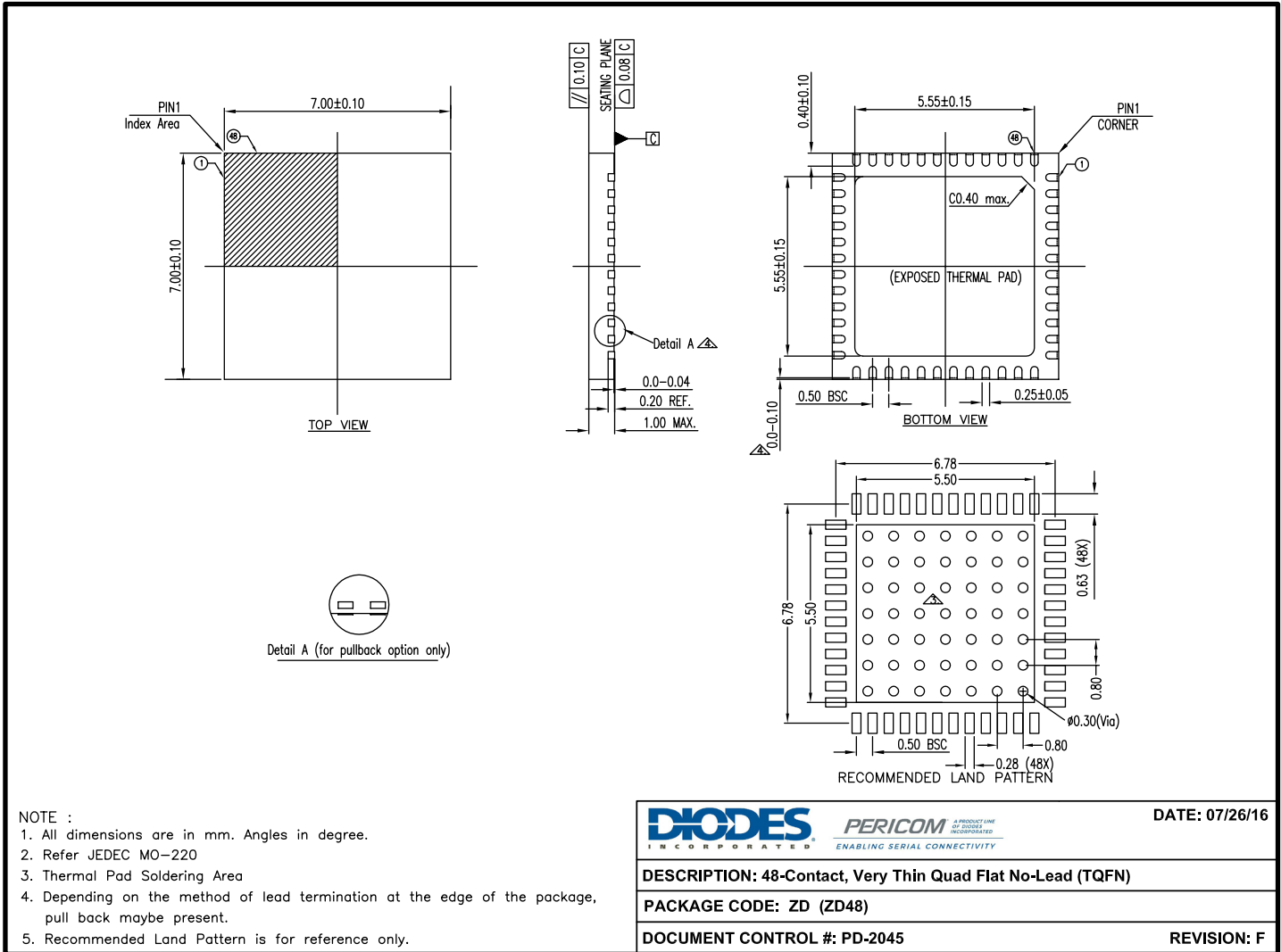

DIODES INCORPORATED	PERICOM A PRODUCT LINE OF DIODES INCORPORATED ENABLING SERIAL CONNECTIVITY	DATE: 07/26/16
DESCRIPTION: 48-Contact, Very Thin Quad Flat No-Lead (TQFN)		
PACKAGE CODE: ZD (ZD48)		
DOCUMENT CONTROL #: PD-2045		REVISION: F

16-0151

For latest package info.

please check: <http://www.diodes.com/design/support/packaging/pericom-packaging/packaging-mechanicals-and-thermal-characteristics/>

Ordering Information

Ordering Code	Package Code	Package Type	Operating Temperature
PI6C5912016ZDIEX	ZD	48-Contact, Very Thin Quad Flat No-Lead (TQFN)	-40°C to 85°C

Notes:

- EU Directive 2002/95/EC (RoHS), 2011/65/EU (RoHS 2) & 2015/863/EU (RoHS 3) compliant. All applicable RoHS exemptions applied.
- See <http://www.diodes.com/quality/lead-free/> for more information about Diodes Incorporated's definitions of Halogen- and Antimony-free, "Green" and Lead-free. Thermal characteristics can be found on the company web site at www.diodes.com/design/support/packaging/
- E = Pb-free and Green
- X suffix = Tape/Reel

IMPORTANT NOTICE

DIODES INCORPORATED MAKES NO WARRANTY OF ANY KIND, EXPRESS OR IMPLIED, WITH REGARDS TO THIS DOCUMENT, INCLUDING, BUT NOT LIMITED TO, THE IMPLIED WARRANTIES OF MERCHANTABILITY AND FITNESS FOR A PARTICULAR PURPOSE (AND THEIR EQUIVALENTS UNDER THE LAWS OF ANY JURISDICTION).

Diodes Incorporated and its subsidiaries reserve the right to make modifications, enhancements, improvements, corrections or other changes without further notice to this document and any product described herein. Diodes Incorporated does not assume any liability arising out of the application or use of this document or any product described herein; neither does Diodes Incorporated convey any license under its patent or trademark rights, nor the rights of others. Any Customer or user of this document or products described herein in such applications shall assume all risks of such use and will agree to hold Diodes Incorporated and all the companies whose products are represented on Diodes Incorporated website, harmless against all damages.

Diodes Incorporated does not warrant or accept any liability whatsoever in respect of any products purchased through unauthorized sales channel.

Should Customers purchase or use Diodes Incorporated products for any unintended or unauthorized application, Customers shall indemnify and hold Diodes Incorporated and its representatives harmless against all claims, damages, expenses, and attorney fees arising out of, directly or indirectly, any claim of personal injury or death associated with such unintended or unauthorized application.

Products described herein may be covered by one or more United States, international or foreign patents pending. Product names and markings noted herein may also be covered by one or more United States, international or foreign trademarks.

This document is written in English but may be translated into multiple languages for reference. Only the English version of this document is the final and determinative format released by Diodes Incorporated.

LIFE SUPPORT

Diodes Incorporated products are specifically not authorized for use as critical components in life support devices or systems without the express written approval of the Chief Executive Officer of Diodes Incorporated. As used herein:

A. Life support devices or systems are devices or systems which:

1. are intended to implant into the body, or

2. support or sustain life and whose failure to perform when properly used in accordance with instructions for use provided in the labeling can be reasonably expected to result in significant injury to the user.

B. A critical component is any component in a life support device or system whose failure to perform can be reasonably expected to cause the failure of the life support device or to affect its safety or effectiveness.

Customers represent that they have all necessary expertise in the safety and regulatory ramifications of their life support devices or systems, and acknowledge and agree that they are solely responsible for all legal, regulatory and safety-related requirements concerning their products and any use of Diodes Incorporated products in such safety-critical, life support devices or systems, notwithstanding any devices- or systems-related information or support that may be provided by Diodes Incorporated. Further, Customers must fully indemnify Diodes Incorporated and its representatives against any damages arising out of the use of Diodes Incorporated products in such safety-critical, life support devices or systems.

Copyright © 2016, Diodes Incorporated

www.diodes.com



Компания «ЭлектроПласт» предлагает заключение долгосрочных отношений при поставках импортных электронных компонентов на взаимовыгодных условиях!

Наши преимущества:

- Оперативные поставки широкого спектра электронных компонентов отечественного и импортного производства напрямую от производителей и с крупнейших мировых складов;
- Поставка более 17-ти миллионов наименований электронных компонентов;
- Поставка сложных, дефицитных, либо снятых с производства позиций;
- Оперативные сроки поставки под заказ (от 5 рабочих дней);
- Экспресс доставка в любую точку России;
- Техническая поддержка проекта, помощь в подборе аналогов, поставка прототипов;
- Система менеджмента качества сертифицирована по Международному стандарту ISO 9001;
- Лицензия ФСБ на осуществление работ с использованием сведений, составляющих государственную тайну;
- Поставка специализированных компонентов (Xilinx, Altera, Analog Devices, Intersil, Interpoint, Microsemi, Aeroflex, Peregrine, Syfer, Eurofarad, Texas Instrument, Miteq, Cobham, E2V, MA-COM, Hittite, Mini-Circuits, General Dynamics и др.);

Помимо этого, одним из направлений компании «ЭлектроПласт» является направление «Источники питания». Мы предлагаем Вам помощь Конструкторского отдела:

- Подбор оптимального решения, техническое обоснование при выборе компонента;
- Подбор аналогов;
- Консультации по применению компонента;
- Поставка образцов и прототипов;
- Техническая поддержка проекта;
- Защита от снятия компонента с производства.



Как с нами связаться

Телефон: 8 (812) 309 58 32 (многоканальный)

Факс: 8 (812) 320-02-42

Электронная почта: org@eplast1.ru

Адрес: 198099, г. Санкт-Петербург, ул. Калинина, дом 2, корпус 4, литера А.