

120 WATT FLEX ATX TYPE WITH ACTIVE PFC

FXA120-W-F SERIES



GENERAL SPECIFICATION

This specification describes the performance characteristics of a grounded, with active PFC function, single phase, 120 watts, 5 output level power supply with ATX form factor. In addition, it defines a worldwide safety requirement and electromagnetic compatibility requirement for FLEX ATX Power Supply

1) INPUT

Description	Min.	Typical	Max.	Condition
Input Voltage	90VAC	115/230V	264VAC	Full Range; 50/60Hz
Input Current(RMS)	2 Amps maximum (excluding output current) at 115 VAC input voltage 1 Amps maximum (excluding output current) at 230 VAC input voltage			
Line Frequency	47Hz	50/60Hz	63Hz	-
INRUSH CURRENT	30 Amps peak max. for one half cycle of AC 115V (cold start) 60 Amps peak max. for one half cycle of AC 230V (cold start)			
Efficiency	The power supply efficiency should not be less than 65% at the Maximum load of paragraph 3.1 with the AC input at any nominal low range of high range voltage specific in paragraph 2.1			
Power Factor Correction >0.95 at Full Load				

2) OUTPUT

2.1) STATIC DC LOAD

NOMINAL VOLTAGE (DC)	LOAD CURRENT		REGULATION (%)
	MIN.	MAX.	
+3.3 Volt	0.5 A	7 A	+/- 5
+5 Volt	1 A	12 A	+/- 5
+12 Volt	0.5 A	5 A	+/- 5
-12 Volt	0 A	0.3 A	+/- 10
+5 Vsb	0 A	1.5 A	+/- 5

NOTE: Regulation shows the percentage of absolute value of nominal output voltage. The total output should be 120W max. +3.3V & +5V combined output should not exceed 70W.

2.2) REMOTE ON/OFF CONTROL

As logic level is LOW: Output voltage is enabled

As logic level is HIGH or floating: Output voltage is disabled.

Note: Logic high level: 3.5-5.25 V, Logic low level: 0-0.5 V

2.3) RIPPLE AND NOISE

The ripple and noise of the outputs should be measured at the full load

Output Voltage	Ripple & Noise(p-p)
+3.3 Volts	50 mV
+5 Volts	60 mV
+12 Volts	120 mV
-12 Volts	120 mV
+5sb Volts	100 MV

NOTE; 20MHz bandwidth ripple & noise is measured by using 0.1uF C.C& 10uF/50V E.C bypassed at the output connector.

2.4) HOLD UP TIME

The power supply unit should maintain its proper output voltage within voltage specifications for at least 20 milliseconds after losing input power under the condition of 95 VAC input with full loading.

3) OVERSHOOT AT TURN-ON/TURN-OFF

Any overshoots during turn-on/turn-off should be less than +/-5% of the nominal output voltage values. No voltage of opposite polarity shall be present on any output during turn-on or turn-off.

4) TEMPERATURE COEFFICIENT

The temperature coefficient of all outputs is +/-0.05% per degree C maximum.

5) PROTECTION:

5.1) OVER VOLTAGE PROTECTION(OVP)

If any over voltage fault occur, the power supply should latch off before any output exceeds its limit below.

NOMINAL VOLTAGE(V)	OVERVOLTAGE RANGE(V)	
	FROM	TO
+3.3	3.7	4.1
+5	5.6	6.5
+12	13.3	14.3

The power supply will not be automatically recovered after the over voltage fault being removed. A manual power reset is necessary.

5.2) SHORT CIRCUIT PROTECTION

Any short circuit occurred on any DC output should not cause any damage to the power supply, but will shut down the power supply. The power supply will not be automatically recovered after the short circuit being removed. A manual power reset is necessary.

5.3) OVERLOAD PROTECTION

An over load protection will be affected when either of the loadings: +5V, +3.3V & +12V exceeds +110% to 160%. The power supply won't be automatically recovered after the overload being removed. It needs to do the input power reset.

6) RISE TIME:

After turning on, less than 20 mS will be needed for the rise of +5V output voltage(measured from 10% point to 95% point on the waveform) to reach its peak.

7) POWER GOOD SIGNAL:

After power-on with nominal AC input, there might be a turn-on delay (between 100 mS to 500mS) before the Power Good Signal is issued, which occurs before +5V output reaches its minimum sense level of +4.75V. When turn-off, the Power Good Signal shall go to a lower level for at least 1 mS before +5V falls under the regulation limit described in paragraph 3.1

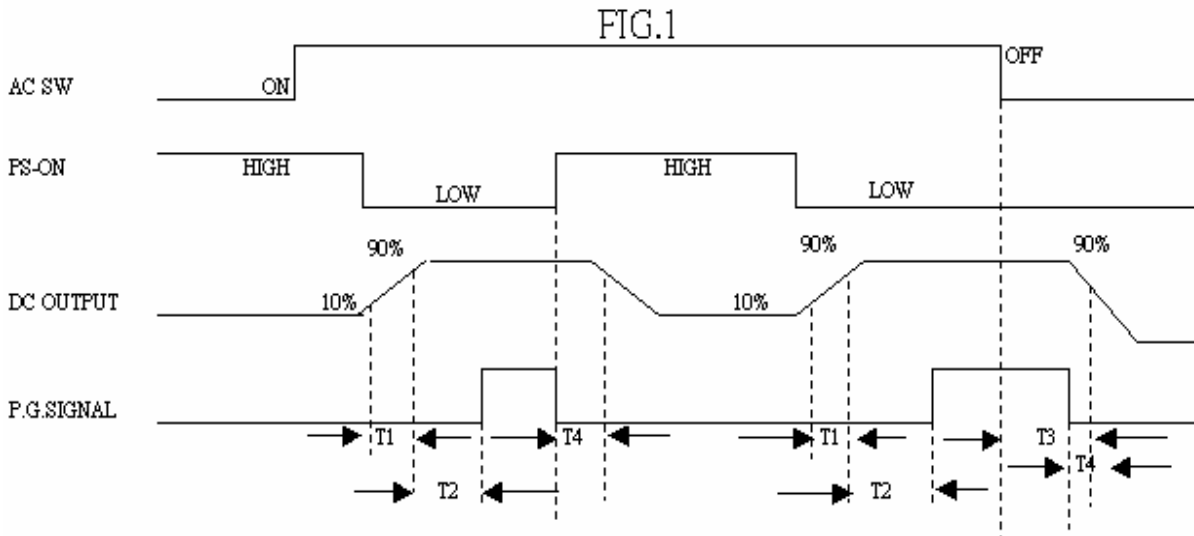

T1: RISE TIME < 20mS

T2: POWER GOOD DELAY TIME 100mS-500mS

T3: HOLD-UP TIME

T4: POWER FAIL DELAY TIME > 1mS

8) SAFETY PROVIDED:

UL60950-1 CSA22.2 60950-1 TUV EN60950 CB IEC60950-1

FCC Class "B" CE EN55022 class "B" EN61000-3-2 class "D" CE CISPR22 Class B

8.1) DIELECTRIC WITHSTAND

- Primary to Secondary : 3000 VAC for 60 Sec
- Primary to Frame Ground : 1500 VAC for 60 Sec.

8.2) INSULATION RESISTANCE

- Primary to Secondary : 20 Meg. Ohms Min. 500 VDC.
- Primary to Frame Ground : 20 Meg. Ohms Min. 500 VDC.
- Secondary to Frame Ground : 10 Meg. Ohms Min. 500 VDC.

9) ENVIRONMENT

9.1) OPERATING

Temperature	0 to 40 degree centigrade
Relative Humidity	10 to 90 percent, non-condensing

9.2) SHIPPING AND STORAGE

Temperature	-40 to +70 degree centigrade
Relative Humidity	5 to 95 percent, non-condensing

10) WARRANTY: One Year (MTBF 80,000 Hrs, DC fan not guaranteed)

11) DIMENSION

Case dimension: 150(L) X 83(W) X 41.5(H)mm

12) PIN ASSIGNMENT

Flex ATX Main Power Supply Connector

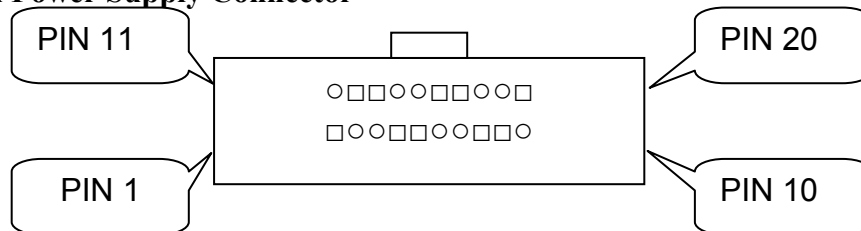

Pin	Signal	Wire	
1	+3.3 VDC	Orange	20AWG
2	+3.3 VDC	Orange	20AWG
3	COM	Black	20AWG
4	+5 VDC	Red	20AWG
5	COM	Black	20AWG
6	+5 VDC	Red	20AWG
7	COM	Black	20AWG
8	POK	Gray	22AWG
9	+5 VSB	Purple	22AWG
10	+12 VDC	Yellow	20AWG

Pin	Signal	Wire	
11	+3.3V VDC	Orange	20AWG
12	-12 VDC	Blue	22AWG
13	COM	Black	20AWG
14	PS-ON	Green	22AWG
15	COM	Black	20AWG
16	COM	Black	20AWG
17	COM	Black	20AWG
18	NC	-	-
19	+5 VDC	Red	20AWG
20	+5 VDC	Red	20AWG



Компания «ЭлектроПласт» предлагает заключение долгосрочных отношений при поставках импортных электронных компонентов на взаимовыгодных условиях!

Наши преимущества:

- Оперативные поставки широкого спектра электронных компонентов отечественного и импортного производства напрямую от производителей и с крупнейших мировых складов;
- Поставка более 17-ти миллионов наименований электронных компонентов;
- Поставка сложных, дефицитных, либо снятых с производства позиций;
- Оперативные сроки поставки под заказ (от 5 рабочих дней);
- Экспресс доставка в любую точку России;
- Техническая поддержка проекта, помощь в подборе аналогов, поставка прототипов;
- Система менеджмента качества сертифицирована по Международному стандарту ISO 9001;
- Лицензия ФСБ на осуществление работ с использованием сведений, составляющих государственную тайну;
- Поставка специализированных компонентов (Xilinx, Altera, Analog Devices, Intersil, Interpoint, Microsemi, Aeroflex, Peregrine, Syfer, Eurofarad, Texas Instrument, Miteq, Cobham, E2V, MA-COM, Hittite, Mini-Circuits, General Dynamics и др.);

Помимо этого, одним из направлений компании «ЭлектроПласт» является направление «Источники питания». Мы предлагаем Вам помощь Конструкторского отдела:

- Подбор оптимального решения, техническое обоснование при выборе компонента;
- Подбор аналогов;
- Консультации по применению компонента;
- Поставка образцов и прототипов;
- Техническая поддержка проекта;
- Защита от снятия компонента с производства.



Как с нами связаться

Телефон: 8 (812) 309 58 32 (многоканальный)

Факс: 8 (812) 320-02-42

Электронная почта: org@eplast1.ru

Адрес: 198099, г. Санкт-Петербург, ул. Калинина, дом 2, корпус 4, литера А.