

**CONSTANT VOLTAGE AND CONSTANT CURRENT CONTROLLER**

**Description**

The AP4312 is a highly integrated solution for a constant voltage/constant current mode SMPS application.

The AP4312 contains one 1.21V voltage reference, one low voltage reference used in current sensing circuit and two operational amplifiers. The 1.21V voltage reference, combined with one operational amplifier, makes of an ideal voltage controller for use in adapters and battery chargers. The low voltage reference, combined with another operational amplifier, makes of an ideal current limiter for output low side current sensing.

The AP4312 is fully compatible with AP4306 in functionality and electrical characteristics except its lower reference voltage for current control loop, thus higher power efficiency in SMPS applications such as low power charger can be realized with AP4312 compared to AP4306.

The AP4312 is available in SOT26 package.

**Features**

- Constant Voltage and Constant Current Control
- Precision Internal Voltage Reference
- Low External Component Count
- Easy Compensation
- Low Supply Current: 180µA
- Current Control Loop Reference: 70mV
- Operating Supply Voltage: 1.7V to 18V
- **Totally Lead-free & Fully RoHS Compliant (Note 1 & 2)**
- **Halogen and Antimony Free. "Green" Device (Note 3)**

Notes: 1. No purposely added lead. Fully EU Directive 2002/95/EC (RoHS) & 2011/65/EU (RoHS 2) compliant.  
 2. See [http://www.diodes.com/quality/lead\\_free.html](http://www.diodes.com/quality/lead_free.html) for more information about Diodes Incorporated's definitions of Halogen- and Antimony-free, "Green" and Lead-free.  
 3. Halogen- and Antimony-free "Green" products are defined as those which contain <900ppm bromine, <900ppm chlorine (<1500ppm total Br + Cl) and <1000ppm antimony compounds.

**Pin Assignments**

(Top View)

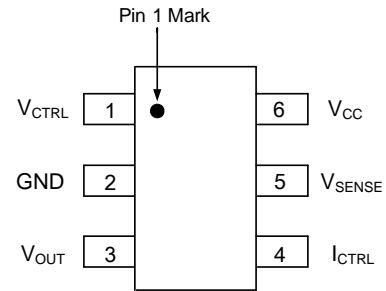

**SOT26 (K6 Package)**

**Applications**

- Adapters
- Battery Chargers

**Typical Applications Circuit**

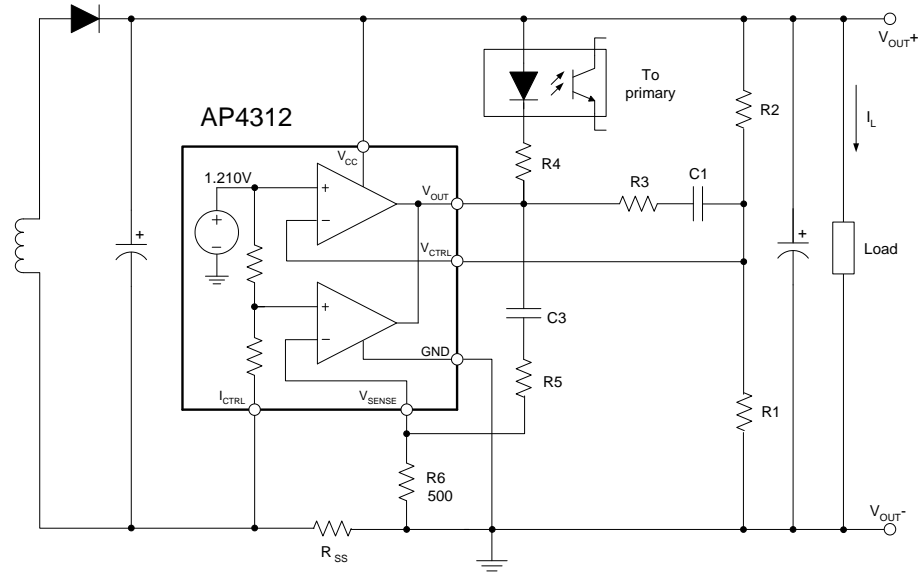

$$V_{OUT} = V_{REF} \times \frac{R1 + R2}{R1}$$

$$CurrentLimit = \frac{V_{SENSE}}{R_{SS}}$$

Typical Application 1

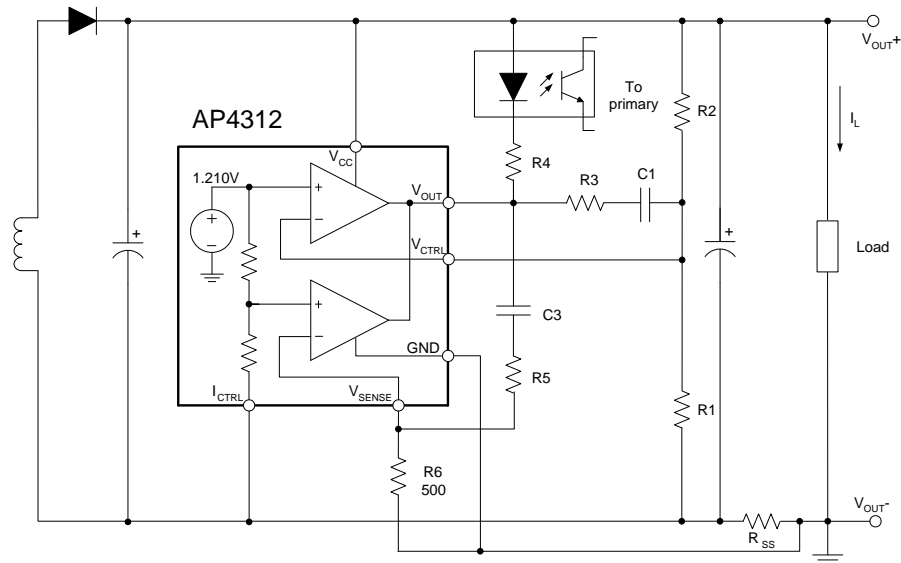

$$V_{OUT} = [V_{REF} + (I_L \times R_{SS})] \times \frac{R1 + R2}{R1} - (I_L \times R_{SS})$$

$$CurrentLimit = \frac{V_{SENSE}}{R_{SS}}$$

Typical Application 2

**Typical Applications Circuit (Cont.)**

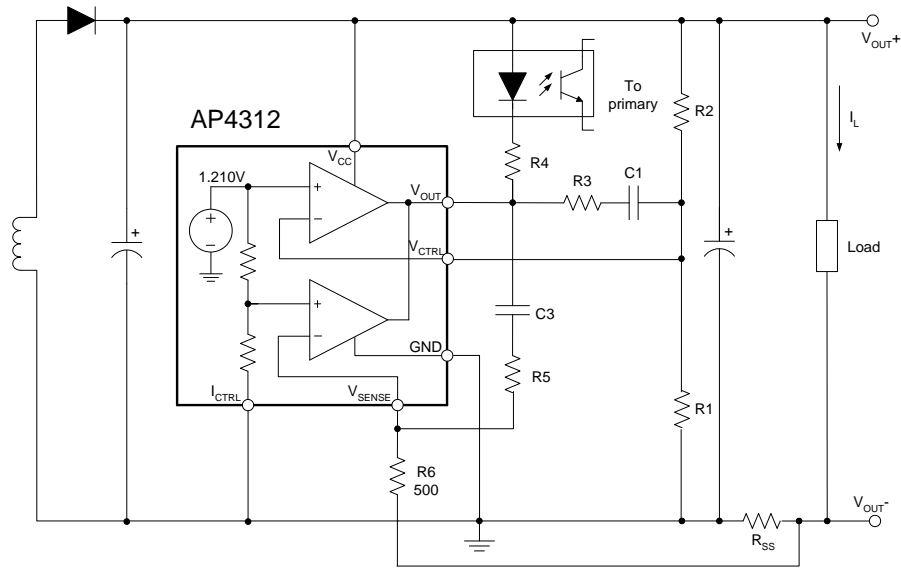

$$V_{OUT} = V_{REF} \times \frac{R1 + R2}{R1} - (I_L \times R_{SS})$$

$$CurrentLimit = \frac{V_{SENSE} \times V_{REF}}{(V_{SENSE} + V_{REF}) \times R_{SS}}$$

Typical Application 3

**Pin Descriptions**

Pin Number	Pin Name	Function
1	V_CTRL	Input pin of the voltage control loop
2	GND	Ground
3	V_OUT	Output pin. Sinking current only
4	I_CTRL	Input pin of the current control loop
5	V_SENSE	Input pin of the current control loop
6	V_CC	Power Supply

## Functional Block Diagram

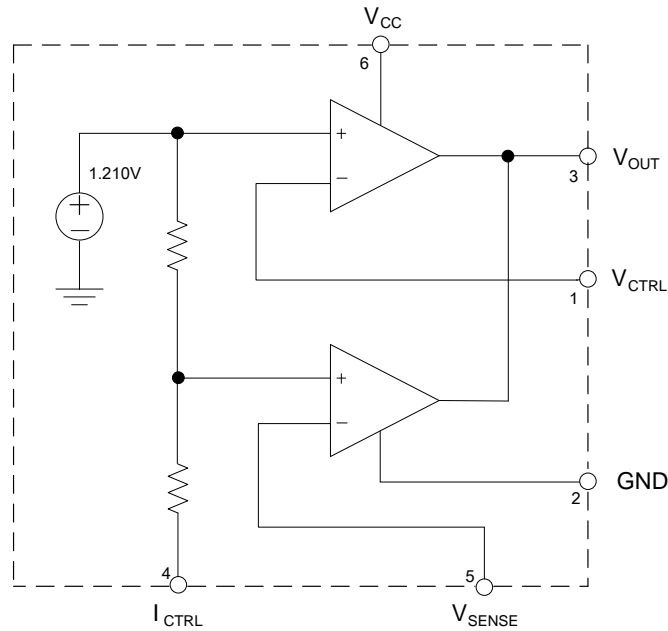

## Absolute Maximum Ratings (Note 4)

Symbol	Parameter	Rating	Unit
$V_{CC}$	Power Supply Voltage	20	V
$V_{IN}$	Input Voltage	-0.3 to $V_{CC}$	V
$T_J$	Junction Temperature	+150	°C
$T_{STG}$	Storage Temperature	-65 to +150	°C
$T_{LEAD}$	Lead Temperature (Soldering, 5sec)	+260	°C
$\theta_{JA}$	Thermal Resistance (Junction to Ambient)	250	°C/W

Note 4: Stresses greater than those listed under "Absolute Maximum Ratings" may cause permanent damage to the device. These are stress ratings only, and functional operation of the device at these or any other conditions beyond those indicated under "Recommended Operating Conditions" is not implied. Exposure to "Absolute Maximum Ratings" for extended periods may affect device reliability.

## Recommended Operating Conditions

Symbol	Parameter	Min	Max	Unit
$V_{CC}$	Power Supply Voltage	1.7	18	V

**Electrical Characteristics** (@V<sub>CC</sub>=5V, T<sub>A</sub>=+25°C, unless otherwise specified.)

Symbol	Parameters	Conditions	Min	Typ	Max	Unit
<b>TOTAL CURRENT CONSUMPTION</b>						
I <sub>CC</sub>	Total Supply Current Not Including the Output Sinking Current	T <sub>A</sub> =+25°C	–	180	–	μA
		-40°C < T <sub>A</sub> < +105°C	–	–	300	
<b>VOLTAGE CONTROL LOOP</b>						
G <sub>mV</sub>	Transconductance of Voltage Control Loop Op-Amp (Sink Current Only)	T <sub>A</sub> =+25°C	1	3.5	–	mA/mV
		-40°C < T <sub>A</sub> < +105°C	–	2.5	–	
V <sub>REF</sub>	Voltage Control Loop Reference	T <sub>A</sub> =+25°C	1.204	1.21	1.216	V
		-40°C < T <sub>A</sub> < +105°C	1.186		1.234	
I <sub>IBV</sub>	Input Bias Current (V <sub>CTRL</sub> )	T <sub>A</sub> =+25°C	–	50	–	nA
		-40°C < T <sub>A</sub> < +105°C	–	100	–	
<b>CURRENT CONTROL LOOP</b>						
G <sub>mI</sub>	Transconductance of Current Control Loop Op-Amp (Sink Current Only)	T <sub>A</sub> =+25°C	1.5	7	–	mA/mV
		-40°C < T <sub>A</sub> < +105°C	1.5	7	–	
V <sub>SENSE</sub>	Current Control Loop Reference	T <sub>A</sub> =+25°C	67.9	70	72.1	mV
		-40°C < T <sub>A</sub> < +105°C	66		74	
I <sub>IBI</sub>	Current Out of Pin I <sub>CTRL</sub> at V <sub>SENSE</sub>	T <sub>A</sub> =+25°C	–	18	–	μA
		-40°C < T <sub>A</sub> < +105°C	–	35	–	
<b>OUTPUT STAGE</b>						
V <sub>OL</sub>	Low Output Voltage Level	T <sub>A</sub> =+25°C, I <sub>SINK</sub> =2mA	–	100	–	mV
		-40°C < T <sub>A</sub> < +105°C, I <sub>SINK</sub> =2mA	–	100	–	
I <sub>OS</sub>	Output Short Circuit Current. Output to V <sub>CC</sub> . Sink Current Only	T <sub>A</sub> =+25°C	–	27	50	mA
		-40°C < T <sub>A</sub> < +105°C	–	35	–	

**Thermal Impedance**

Symbol	Parameter	Value	Unit
θ <sub>JC</sub>	Thermal Resistance (Junction to Case)	84	°C/W

**Performance Characteristics**

**Voltage Control Loop Reference vs. Ambient Temperature**

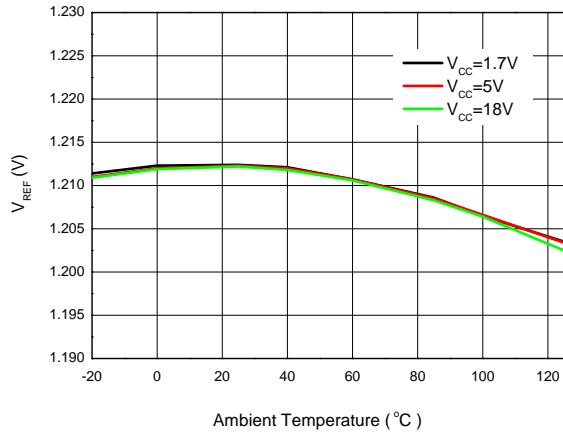

**Current Control Loop Reference vs. Ambient Temperature**

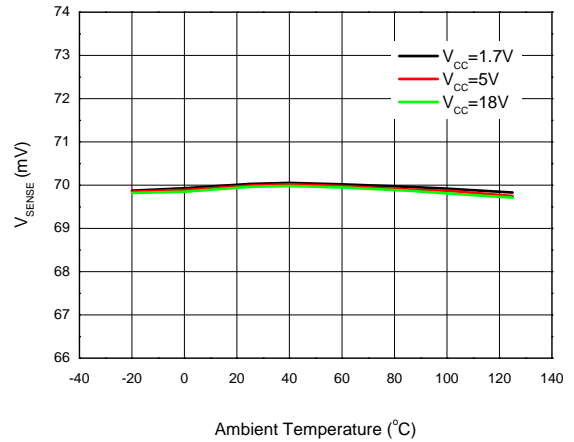

**Input Bias Current ( $V_{CTRL}$ ) vs. Ambient Temperature**

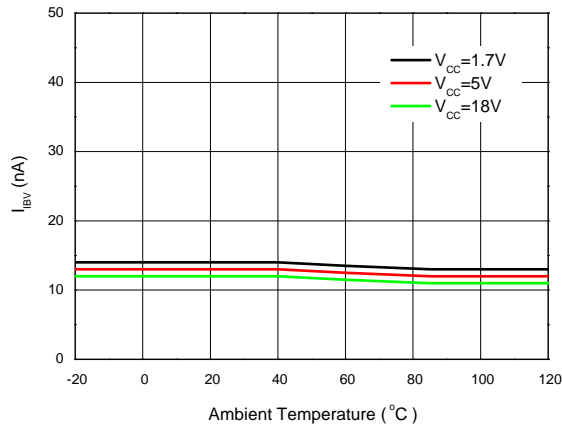

**Current Out of Pin  $I_{CTRL}$  at  $V_{SENSE}$  vs. Ambient Temperature**

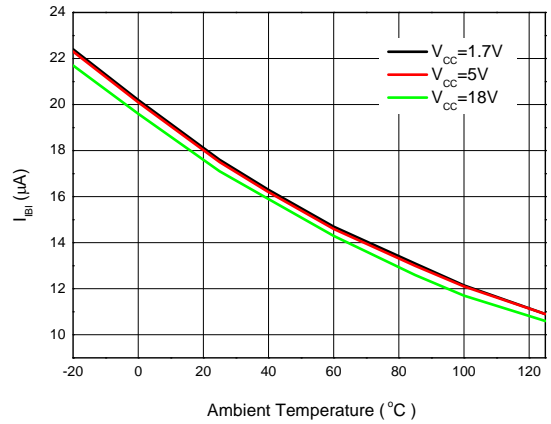

**Transconductance of Voltage Control Loop Op-Amp vs. Ambient Temperature**

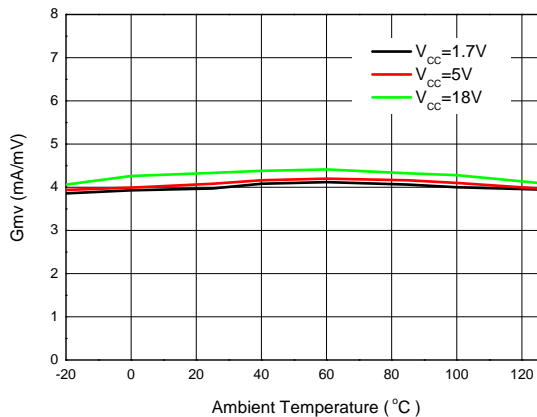

**Transconductance of Current Control Loop Op-Amp vs. Ambient Temperature**

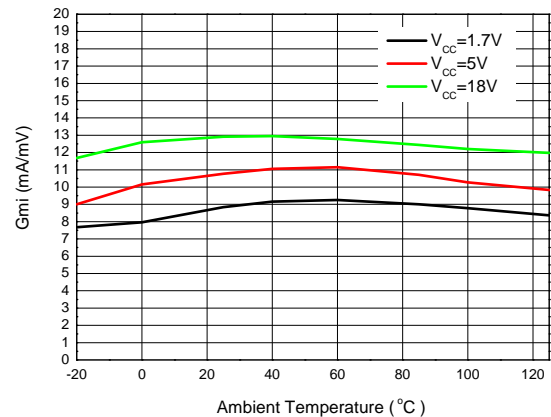

**Performance Characteristics (Cont.)**

**Low Output Level of Voltage Control Loop Op-Amp vs. Ambient Temperature**

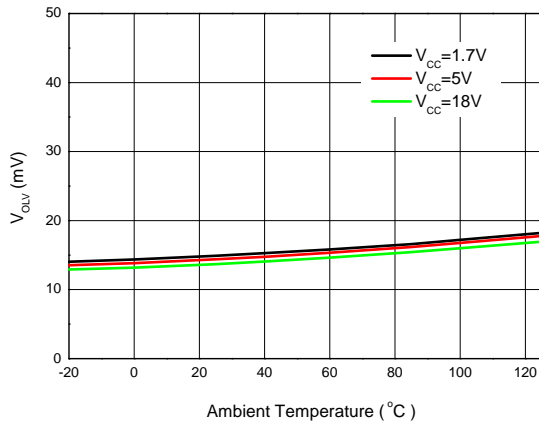

**Low Output Level of Current Control Loop Op-Amp vs. Ambient Temperature**

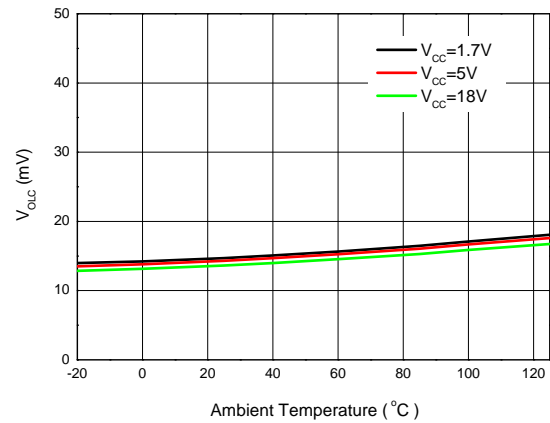

**Output Short Circuit Current of Voltage Control Loop Op-Amp vs. Ambient Temperature**

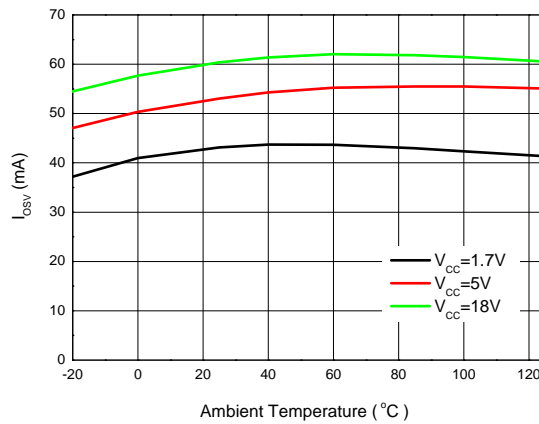

**Output Short Circuit Current of Current Control Loop Op-Amp vs. Ambient Temperature**

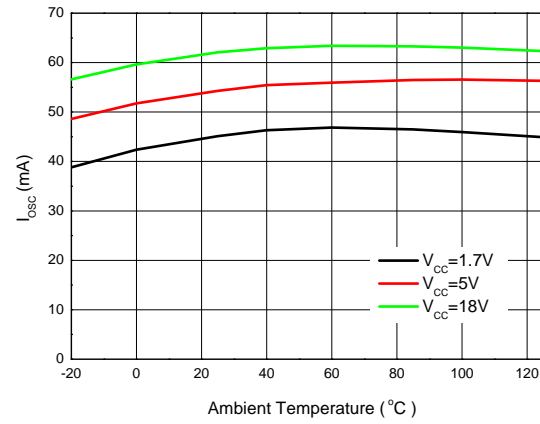

**Total Supply Current Not Including the Output Sinking Current vs. Ambient Temperature**

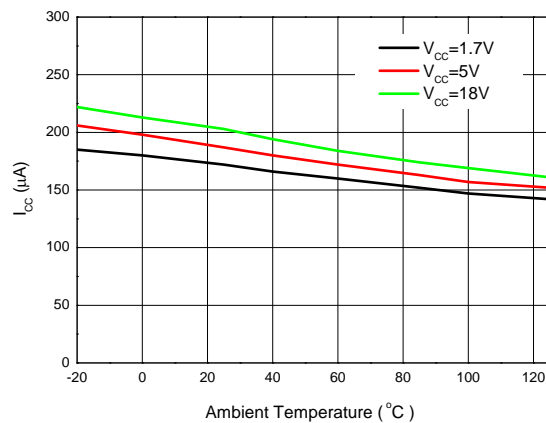

**Low Output Voltage Level vs. Sink Current**

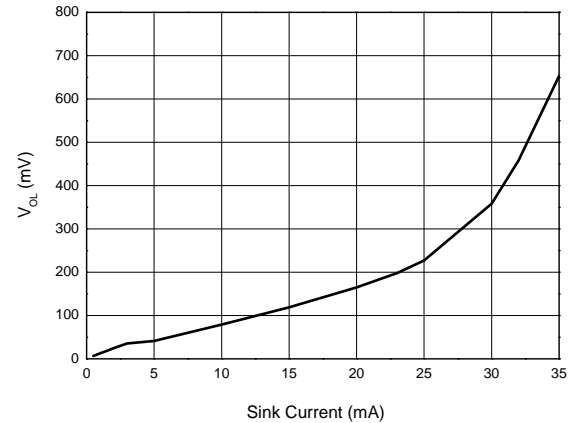

**Ordering Information**

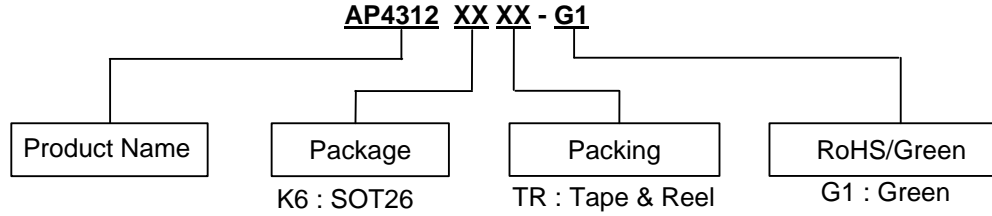

Diodes IC's Pb-free products with "G1" suffix in the part number, are RoHS compliant and green.

Package	Part Number	Marking ID	Packing
SOT26	AP4312K6TR-G1	GKD	3000/Tape & Reel

**Marking Information**

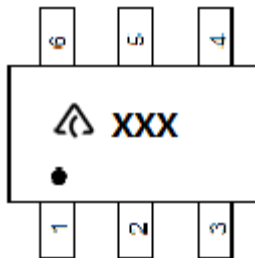

 : Logo  
 XXX: Marking ID (See ordering information)



**Package Outline Dimensions** (All dimensions in mm(inch).)

(1) Package Type: SOT26

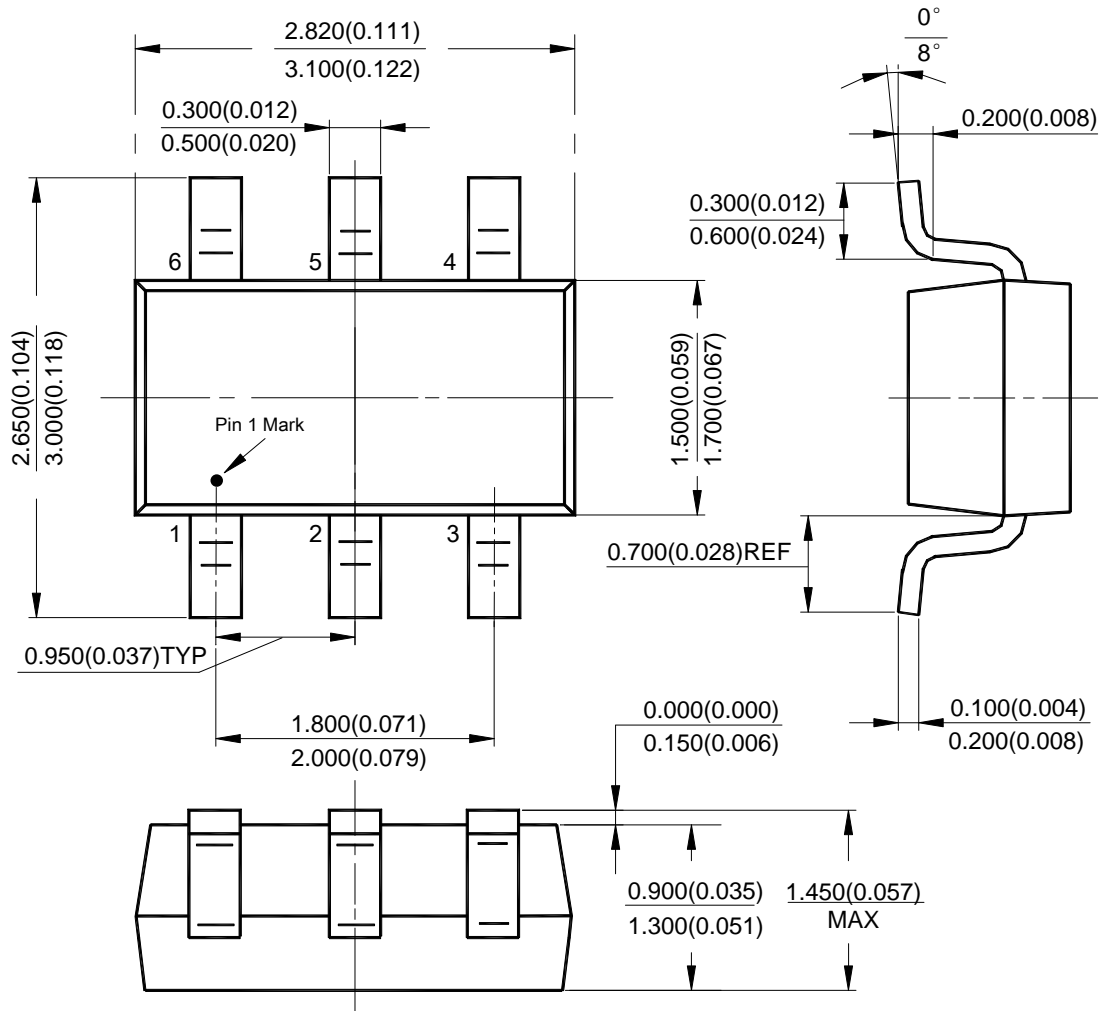

**Suggested Pad Layout**

(1) Package Type: SOT26

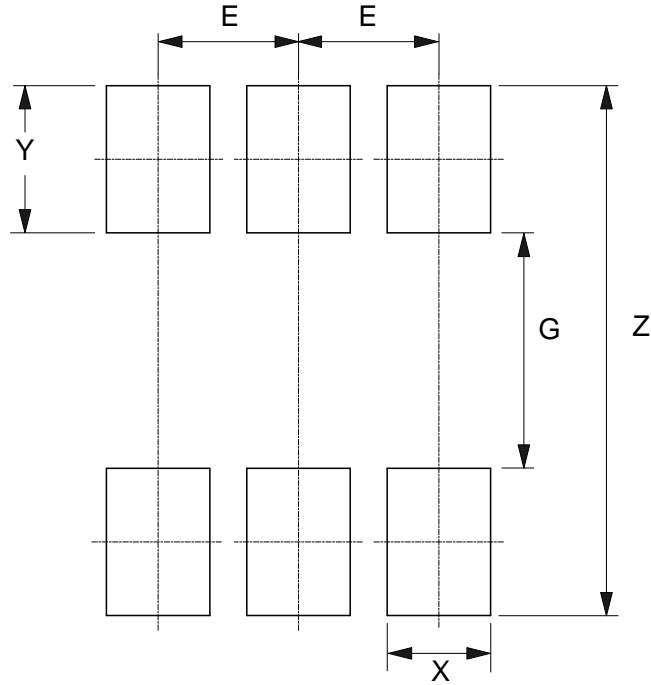

Dimensions	Z (mm)/(inch)	G (mm)/(inch)	X (mm)/(inch)	Y (mm)/(inch)	E (mm)/(inch)
Value	3.600/0.142	1.600/0.063	0.700/0.028	1.000/0.039	0.950/0.037

**IMPORTANT NOTICE**

DIODES INCORPORATED MAKES NO WARRANTY OF ANY KIND, EXPRESS OR IMPLIED, WITH REGARDS TO THIS DOCUMENT, INCLUDING, BUT NOT LIMITED TO, THE IMPLIED WARRANTIES OF MERCHANTABILITY AND FITNESS FOR A PARTICULAR PURPOSE (AND THEIR EQUIVALENTS UNDER THE LAWS OF ANY JURISDICTION).

Diodes Incorporated and its subsidiaries reserve the right to make modifications, enhancements, improvements, corrections or other changes without further notice to this document and any product described herein. Diodes Incorporated does not assume any liability arising out of the application or use of this document or any product described herein; neither does Diodes Incorporated convey any license under its patent or trademark rights, nor the rights of others. Any Customer or user of this document or products described herein in such applications shall assume all risks of such use and will agree to hold Diodes Incorporated and all the companies whose products are represented on Diodes Incorporated website, harmless against all damages.

Diodes Incorporated does not warrant or accept any liability whatsoever in respect of any products purchased through unauthorized sales channel. Should Customers purchase or use Diodes Incorporated products for any unintended or unauthorized application, Customers shall indemnify and hold Diodes Incorporated and its representatives harmless against all claims, damages, expenses, and attorney fees arising out of, directly or indirectly, any claim of personal injury or death associated with such unintended or unauthorized application.

Products described herein may be covered by one or more United States, international or foreign patents pending. Product names and markings noted herein may also be covered by one or more United States, international or foreign trademarks.

This document is written in English but may be translated into multiple languages for reference. Only the English version of this document is the final and determinative format released by Diodes Incorporated.

**LIFE SUPPORT**

Diodes Incorporated products are specifically not authorized for use as critical components in life support devices or systems without the express written approval of the Chief Executive Officer of Diodes Incorporated. As used herein:

A. Life support devices or systems are devices or systems which:

1. are intended to implant into the body, or
2. support or sustain life and whose failure to perform when properly used in accordance with instructions for use provided in the labeling can be reasonably expected to result in significant injury to the user.

B. A critical component is any component in a life support device or system whose failure to perform can be reasonably expected to cause the failure of the life support device or to affect its safety or effectiveness.

Customers represent that they have all necessary expertise in the safety and regulatory ramifications of their life support devices or systems, and acknowledge and agree that they are solely responsible for all legal, regulatory and safety-related requirements concerning their products and any use of Diodes Incorporated products in such safety-critical, life support devices or systems, notwithstanding any devices- or systems-related information or support that may be provided by Diodes Incorporated. Further, Customers must fully indemnify Diodes Incorporated and its representatives against any damages arising out of the use of Diodes Incorporated products in such safety-critical, life support devices or systems.

Copyright © 2013, Diodes Incorporated

[www.diodes.com](http://www.diodes.com)



Компания «ЭлектроПласт» предлагает заключение долгосрочных отношений при поставках импортных электронных компонентов на взаимовыгодных условиях!

Наши преимущества:

- Оперативные поставки широкого спектра электронных компонентов отечественного и импортного производства напрямую от производителей и с крупнейших мировых складов;
- Поставка более 17-ти миллионов наименований электронных компонентов;
- Поставка сложных, дефицитных, либо снятых с производства позиций;
- Оперативные сроки поставки под заказ (от 5 рабочих дней);
- Экспресс доставка в любую точку России;
- Техническая поддержка проекта, помощь в подборе аналогов, поставка прототипов;
- Система менеджмента качества сертифицирована по Международному стандарту ISO 9001;
- Лицензия ФСБ на осуществление работ с использованием сведений, составляющих государственную тайну;
- Поставка специализированных компонентов (Xilinx, Altera, Analog Devices, Intersil, Interpoint, Microsemi, Aeroflex, Peregrine, Syfer, Eurofarad, Texas Instrument, Miteq, Cobham, E2V, MA-COM, Hittite, Mini-Circuits, General Dynamics и др.);

Помимо этого, одним из направлений компании «ЭлектроПласт» является направление «Источники питания». Мы предлагаем Вам помощь Конструкторского отдела:

- Подбор оптимального решения, техническое обоснование при выборе компонента;
- Подбор аналогов;
- Консультации по применению компонента;
- Поставка образцов и прототипов;
- Техническая поддержка проекта;
- Защита от снятия компонента с производства.



#### Как с нами связаться

**Телефон:** 8 (812) 309 58 32 (многоканальный)

**Факс:** 8 (812) 320-02-42

**Электронная почта:** [org@eplast1.ru](mailto:org@eplast1.ru)

**Адрес:** 198099, г. Санкт-Петербург, ул. Калинина, дом 2, корпус 4, литера А.