

TOSHIBA Bi-CD Integrated Circuit Silicon Monolithic

TB67S158FTG

1. Summary/Features/Appearance

Constant voltage control DMOS driver incorporating 3 function modes (full parallel input, clock input, and serial input) and a large mode.

Summary

The TB67S158 is a constant voltage control DMOS driver. It can operate maximum of two unipolar stepping motors (max).

MODE1: Full parallel input (similar to transistor array)

MODE2: CLK input

MODE3: Serial input

MODE4: Large mode

Output voltage of 80V and maximum current of 1.5A are realized by applying BiCD process. Motor can be driven by single power supply of VM with the internal regulator.

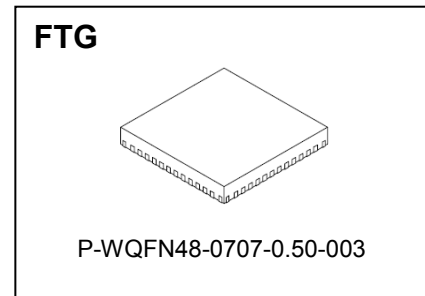

Weight: 1.1g (typ.)

Features

- Capable of operating maximum of two 2-phase unipolar stepping motors by one chip.
- High voltage and current (as for specifications, please refer to the absolute maximum ratings and operation ranges).
- Low on resistance ($R_{on}=0.5\Omega$ (typ.)) of output step is realized by BiCD process.
- Built-in VCC regulator for internal circuit control (capable of operating by only VM power supply)
- Capable of constant voltage driving (corresponding to 2-phase and 1-2-phase excitation drives)
- Full brake (all-phase excitation) mode function (enable only for CLK mode and Large mode)
- Built-in thermal shutdown circuit (TSD), over current detection (ISD), and power on reset of VM power supply
- ALERT signal can be outputted to outside when thermal shutdown circuit (TSD) or over current detection (ISD) operates (disenable in CLK mode)

Note) Please be careful about the thermal conditions during use.

2. Block diagram: MODE 1 (Full parallel mode)

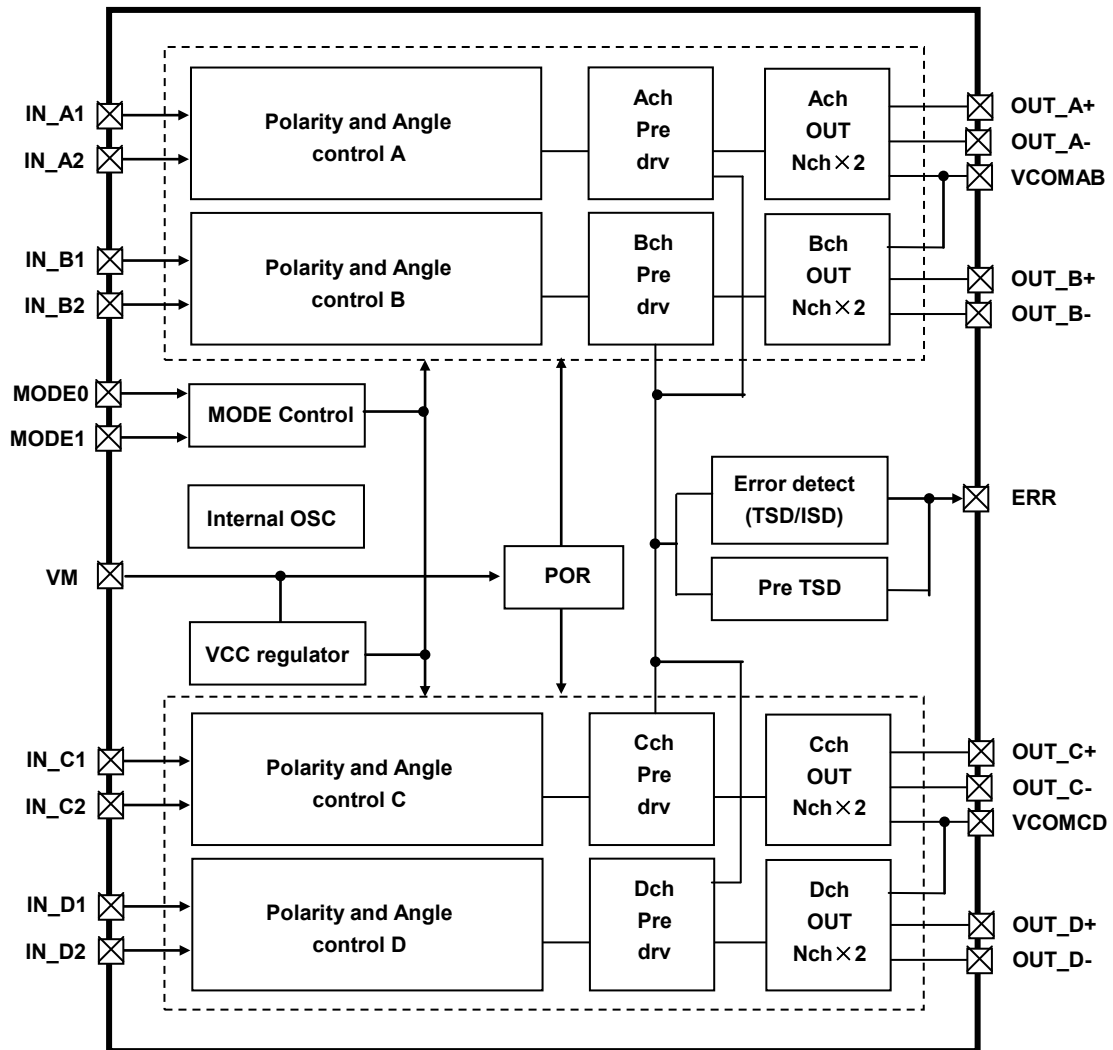

3. Pin name/assignment MODE1 (Full parallel mode)

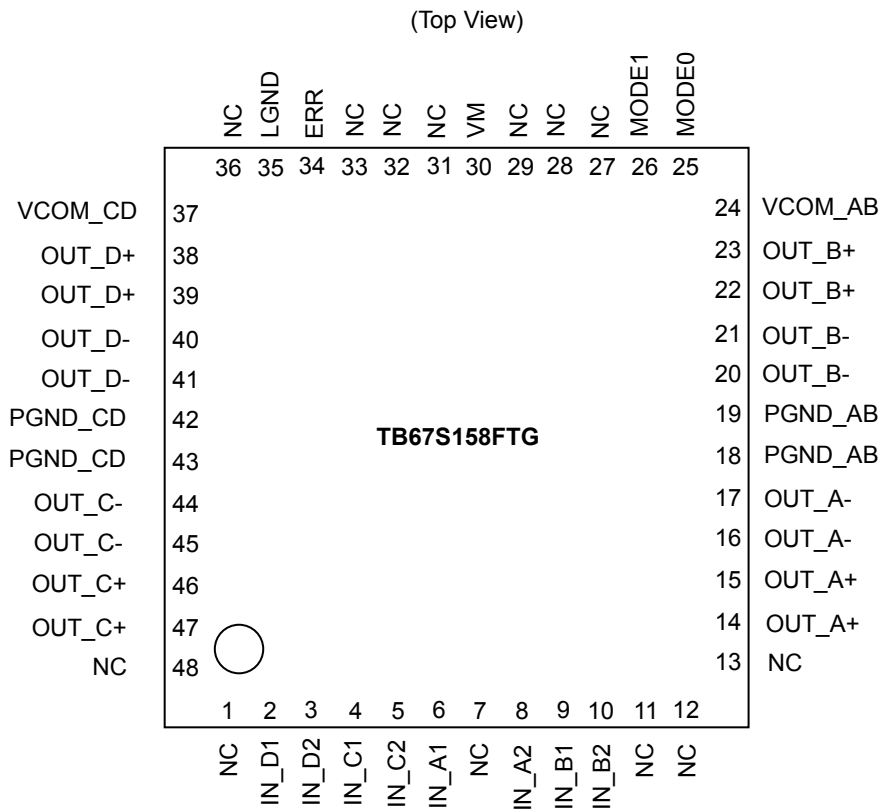

(*) Please mount the four corner pins of the QFN package and the exposed pad to the GND area of the PCB.

3-1. Application Notes

1) All the grounding wires of the device must run on the solder mask on the PCB and be externally terminated at only one point. Also, a grounding method should be considered for efficient heat dissipation.

2) When setting pin of each mode is controlled by SW, the voltage should be pull-up to the power supply which is the same voltage of the input signal or pull-down to the GND in order to avoid Hi-Z.

3) Careful attention should be paid to the layout of the output, VM and GND traces, to avoid short circuits across output pins or to the power supply or ground. If such a short circuit occurs, the device may be permanently damaged.

4) Also, the utmost care should be taken for pattern designing and implementation of the device since it has power supply pins (VM, OUT, GND, etc.) through which a particularly large current may run. If these pins are wired incorrectly, an operation error may occur or the device may be destroyed.

The logic input pins must also be wired correctly. Otherwise, the device may be damaged owing to a current running through the IC that is larger than the specified current.

3-2. Pin assignment of the TB67S158 (QFN48)

| Pin No. | Full parallel (MODE0=L,MODE1=L) | CLK (MODE0=H,MODE1=L) | Serial/Parallel (MODE0=L,MODE1=H) | Large (MODE0=H,MODE1=H) |
|---------|------------------------------------|--------------------------|--------------------------------------|----------------------------|
| 1 | NC | NC | NC | NC |
| 2 | IN_D1 | DMODE1_CD | DATA | NC |
| 3 | IN_D2 | DMODE2_CD | CLK | NC |
| 4 | IN_C1 | DMODE1_AB | ALM | DMODE1 |
| 5 | IN_C2 | DMODE2_AB | NC | DMODE2 |
| 6 | IN_A1 | CW/CCW_AB | CLR | CW/CCW |
| 7 | NC | NC | NC | NC |
| 8 | IN_A2 | RESET_AB | GATE | RESET |
| 9 | IN_B1 | ENABLE_AB | STBY | ENBLE |
| 10 | IN_B2 | CLK_AB | LATCH | CLK |
| 11 | NC | NC | NC | NC |
| 12 | NC | NC | NC | NC |
| 13 | NC | NC | NC | NC |
| 14 | OUT_A+ | OUT_A+ | OUT_A+ | OUT_A+ |
| 15 | OUT_A+ | OUT_A+ | OUT_A+ | OUT_A+ |
| 16 | OUT_A- | OUT_A- | OUT_A- | OUT_A- |
| 17 | OUT_A- | OUT_A- | OUT_A- | OUT_A- |
| 18 | PGND_AB | PGND_AB | PGND_AB | PGND_AB |
| 19 | PGND_AB | PGND_AB | PGND_AB | PGND_AB |
| 20 | OUT_B- | OUT_B- | OUT_B- | OUT_B- |
| 21 | OUT_B- | OUT_B- | OUT_B- | OUT_B- |
| 22 | OUT_B+ | OUT_B+ | OUT_B+ | OUT_B+ |
| 23 | OUT_B+ | OUT_B+ | OUT_B+ | OUT_B+ |
| 24 | VCOM_AB | VCOM_AB | VCOM_AB | VCOM_AB |
| 25 | MODE0 | MODE0 | MODE0 | MODE0 |
| 26 | MODE1 | MODE1 | MODE1 | MODE1 |
| 27 | NC | CW/CCW_CD | NC | NC |
| 28 | NC | CLK_CD | NC | NC |
| 29 | NC | NC | NC | NC |
| 30 | VM | VM | VM | VM |
| 31 | NC | NC | NC | NC |
| 32 | NC | ENABLE_CD | NC | NC |
| 33 | NC | RESET_CD | NC | NC |
| 34 | ERR | ERR | ERR | ERR |
| 35 | LGND | LGND | LGND | LGND |
| 36 | NC | NC | NC | NC |
| 37 | VCOM_CD | VCOM_CD | VCOM_CD | VCOM_CD |
| 38 | OUT_D+ | OUT_D+ | OUT_D+ | OUT_D+ |
| 39 | OUT_D+ | OUT_D+ | OUT_D+ | OUT_D+ |
| 40 | OUT_D- | OUT_D- | OUT_D- | OUT_D- |
| 41 | OUT_D- | OUT_D- | OUT_D- | OUT_D- |
| 42 | PGND_CD | PGND_CD | PGND_CD | PGND_CD |
| 43 | PGND_CD | PGND_CD | PGND_CD | PGND_CD |
| 44 | OUT_C- | OUT_C- | OUT_C- | OUT_C- |
| 45 | OUT_C- | OUT_C- | OUT_C- | OUT_C- |
| 46 | OUT_C+ | OUT_C+ | OUT_C+ | OUT_C+ |
| 47 | OUT_C+ | OUT_C+ | OUT_C+ | OUT_C+ |
| 48 | NC | NC | NC | NC |

3-3. Pin description of the TB67S158 (QFN48)

| Pin No. | Full parallel (MODE0=L,MODE1=L) | CLK (MODE0=H,MODE1=L) | Serial/Parallel (MODE0=L,MODE1=H) | Large (MODE0=H,MODE1=H) |
|---------|--|---|---|--|
| 1 | NC | NC | NC | NC |
| 2 | OUT_D+ ON pin | Setting pin (1_CD) of motor excitation system | Input pin for serial data | NC |
| 3 | OUT_D- ON pin | Setting pin (2_CD) of motor excitation system | Input pin for serial clock | NC |
| 4 | OUT_C+ ON pin | Setting pin (1_AB) of motor excitation system | Output pin for rising temperature detection | Setting pin (1) of motor excitation system |
| 5 | OUT_C- ON pin | Setting pin (2_AB) of motor excitation system | NC | Setting pin (2) of motor excitation system |
| 6 | OUT_A+ ON pin | Setting pin (_AB) for rotating direction | Clear pin for storage register | Setting pin for rotating direction |
| 7 | NC | NC | NC | NC |
| 8 | OUT_A- ON pin | Reset pin (AB) of electrical angle | Clear pin for storage register | Reset pin of electrical angle |
| 9 | OUT_B+ ON pin | ON/OFF setting pin (_AB) for motor output | Standby setting pin | ON/OFF setting pin for motor output |
| 10 | OUT_B- ON pin | CLK Input pin (_AB) | Input pin for serial latch | CLK Input pin |
| 11 | NC | NC | NC | NC |
| 12 | NC | NC | NC | NC |
| 13 | NC | NC | NC | NC |
| 14 | Output + pin for phase A | Output + pin for phase A | Output + pin for phase A | Output + pin for phase A |
| 15 | Output + pin for phase A | Output + pin for phase A | Output + pin for phase A | Output + pin for phase A |
| 16 | Output - pin for phase A | Output - pin for phase A | Output - pin for phase A | Output - pin for phase A |
| 17 | Output - pin for phase A | Output - pin for phase A | Output - pin for phase A | Output - pin for phase A |
| 18 | Power ground pin | Power ground pin | Power ground pin | Power ground pin |
| 19 | Power ground pin | Power ground pin | Power ground pin | Power ground pin |
| 20 | Output - pin for phase B | Output - pin for phase B | Output - pin for phase B | Output - pin for phase B |
| 21 | Output - pin for phase B | Output - pin for phase B | Output - pin for phase B | Output - pin for phase B |
| 22 | Output + pin for phase B | Output + pin for phase B | Output + pin for phase B | Output + pin for phase B |
| 23 | Output + pin for phase B | Output + pin for phase B | Output + pin for phase B | Output + pin for phase B |
| 24 | Common pin for phase A and B | Common pin for phase A and B | Common pin for phase A and B | Common pin for phase A and B |
| 25 | Switching pin for I/F MODE (L setting) | Switching pin for I/F MODE (H setting) | Switching pin for I/F MODE (L setting) | Switching pin for I/F MODE (H setting) |
| 26 | Switching pin for I/F MODE (L setting) | Switching pin for I/F MODE (L setting) | Switching pin for I/F MODE (H setting) | Switching pin for I/F MODE (H setting) |
| 27 | NC | Setting pin (_CD) for rotating direction | NC | NC |
| 28 | NC | Input pin (_CD) for CLK | NC | NC |
| 29 | NC | NC | NC | NC |
| 30 | Pin for main power supply | Pin for main power supply | Pin for main power supply | Pin for main power supply |
| 31 | NC | NC | NC | NC |
| 32 | NC | ON/OFF setting pin (_CD) for motor output | NC | NC |
| 33 | NC | Reset pin (AB) of electrical angle | NC | NC |
| 34 | Output pin for abnormal detection | Output pin for abnormal detection | Output pin for abnormal detection | Output pin for abnormal detection |
| 35 | Logic ground pin | Logic ground pin | Logic ground pin | Logic ground pin |
| 36 | NC | NC | NC | NC |
| 37 | Common pin for phase C and D | Common pin for phase C and D | Common pin for phase C and D | Common pin for phase C and D |
| 38 | Output + pin for phase D | Output + pin for phase D | Output + pin for phase D | Output + pin for phase D |
| 39 | Output + pin for phase D | Output + pin for phase D | Output + pin for phase D | Output + pin for phase D |
| 40 | Output - pin for phase D | Output - pin for phase D | Output - pin for phase D | Output - pin for phase D |
| 41 | Output - pin for phase D | Output - pin for phase D | Output - pin for phase D | Output - pin for phase D |
| 42 | Power ground pin | Power ground pin | Power ground pin | Power ground pin |
| 43 | Power ground pin | Power ground pin | Power ground pin | Power ground pin |
| 44 | Output - pin for phase C | Output - pin for phase C | Output - pin for phase C | Output - pin for phase C |
| 45 | Output - pin for phase C | Output - pin for phase C | Output - pin for phase C | Output - pin for phase C |
| 46 | Output + pin for phase C | Output + pin for phase C | Output + pin for phase C | Output + pin for phase C |
| 47 | Output + pin for phase C | Output + pin for phase C | Output + pin for phase C | Output + pin for phase C |
| 48 | NC | NC | NC | NC |

4. Functional/Operation description

4-1.Pin interface

TB67S158FTG

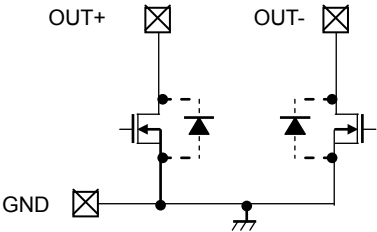
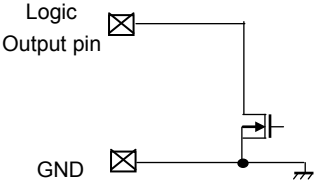
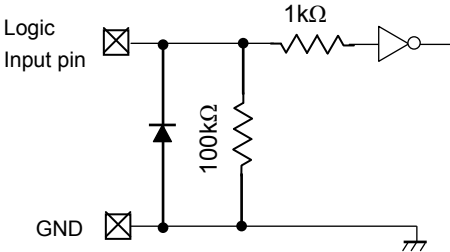

The equivalent circuit diagrams may be simplified or some parts of them may be omitted for explanatory purposes.

Protection circuit

Note: Logic pin is pull-down or pull-up by the resistor of about 100 k Ω in the IC.
(Confirm the input equivalent circuit.)

Functional descriptionISD (over current detection)

ISD turns off the output of the motor when it detects over current (exceeding absolute maximum rating) in the output transistors. It is cleared when VM power supply is applied again or configured standby mode.

TSD (thermal shutdown circuit)

TSD turns off all outputs of the motor when it detects abnormal temperature ($T_j = 160^\circ\text{C}$ (typ.)) of the IC. It is cleared when VM power supply is applied again or configured standby mode.

VMR (VM power supply monitor) circuit

When the voltage of VM is higher than the specified value, output is set high level. When it is lower than the specified value, output is set low (internal status).

POR (Power On Reset) circuit

When both VMR and VCCR are high: Logic transistors = active, Other states: Logic transistors = OFF

5. MODE pin

| MODE1 | MODE0 | Function | |
|-------|-------|----------|---|
| L | L | Mode1 | Full parallel control I/F (Similar operation of transistor array) |
| L | H | Mode2 | I/F of CLK input |
| H | L | Mode3 | Serial/Parallel conversion control I/F |
| H | H | Mode4 | Large mode (Input I/F of CLK) |

6. Pin function of full parallel control IF (Mode1)

IN_X pin can control each transistor directly like transistor array.

| IN_A1 | IN_A2 | IN_B1 | IN_B2 | Function |
|-------|-------|-------|-------|------------|
| L | | - | - | OUT_A+=OFF |
| H | | - | - | OUT_A+=ON |
| - | L | - | - | OUT_A-=OFF |
| - | H | - | - | OUT_A-=ON |
| - | - | L | - | OUT_B+=OFF |
| - | - | H | - | OUT_B+=ON |
| - | - | - | L | OUT_B-=OFF |
| - | - | - | H | OUT_B-=ON |

| IN_C1 | IN_C2 | IN_D1 | IN_D2 | Function |
|-------|-------|-------|-------|------------|
| L | | - | - | OUT_C+=OFF |
| H | | - | - | OUT_C+=ON |
| - | L | - | - | OUT_C-=OFF |
| - | H | - | - | OUT_C-=ON |
| - | - | L | - | OUT_D+=OFF |
| - | - | H | - | OUT_D+=ON |
| - | - | - | L | OUT_D-=OFF |
| - | - | - | H | OUT_D-=ON |

6-1 ERR (output function of abnormal detection)

| ERR output | Function |
|------------|---------------------------------|
| H | Normal operation |
| L | Abnormal detection (TSD or ISD) |

ERR pin is a logic output pin of open drain type. It outputs high level (pull-up voltage level) in the normal operation. It outputs low (GND level) when TSD or ISD operates. When TSD or ISD detection is cleared, high level is outputted.

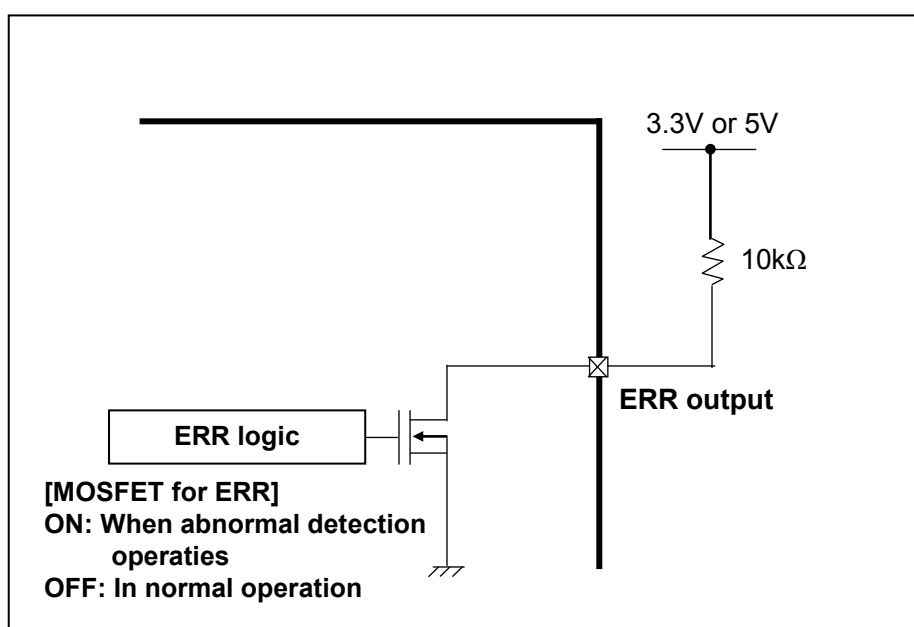

7. Pin function of I/F (Mode2) of CLK input

7-1. Function of CLK

The electrical angle gains one angle for every CLK. The signal is reflected at the up edge.

| CLK_X | Function |
|-------|---------------------------------|
| ↑ | To the next step at the up edge |
| ↓ | - (Prior state is kept) |

* "X" of CLK_X stands for AB and CD.

7-2. Function of ENABLE

In driving stepping motor, it configures ON and OFF of the current. OFF mode (High impedance: Z) and the operation mode of the motor are switched by controlling this pin. In turning on or turning off the power supply, this pin must be fixed low.

| ENABLE_X | Function |
|----------|--|
| H | Output transistor is ON (Normal operation) |
| L | Output transistor is OFF (High impedance: Z) |

* "X" of ENABLE_X stands for AB and CD.

7-3. Function of CW/CCW and output pin

It switches the rotating direction of the stepping motor.
 CW: The current of phase A is outputted 90°ahead of phase B.
 CCW: The current of phase B is outputted 90°ahead of phase A.

| CW/CCW_X | Input function | OUT (+) | OUT (-) |
|----------|------------------------|---------|---------|
| H | Forward rotating (CW) | H | L |
| L | Reverse rotating (CCW) | L | H |

* "X" of CW/CCW_X stands for AB and CD.

7-4. Function of RESET

| RESET input | Input function |
|-------------|------------------------|
| H | RESET electrical angle |
| L | Normal operation |

The current of each phase in RESET mode is as follows. (MO_OUT pin: Low)

The function of this pin synchronizes with AB and CD. So, the electrical angles of AB and CD are initialized by this pin at the same timing.

| Excitation mode | OUT_A+ (C+) | OUT_A- (C-) | OUT_B+ (D+) | OUT_B- (D-) |
|----------------------|-------------|-------------|-------------|-------------|
| 2-phase excitation | ON | OFF | ON | OFF |
| 1-2-phase excitation | ON | OFF | ON | OFF |

7-5. Function of excitation setting

| DMODE1_X | DMODE2_X | Function |
|----------|----------|--|
| L | L | STANDBY MODE Turn off OSCM, Turn off output transistor, 2-phase excitation mode |
| L | H | 2-phase excitation |
| H | L | 1-2-excitation |
| H | H | BREAK mode (turn on all steps of output transistors) |

It is recommended to change DMODE1 and 2 after RESET is configured Low in the initial state (MO_OUT = Low).

* "X" of DMODE1,2_X stands for AB and CD.

<2-phase excitation in CW>

| | OUT_A+ (C+) | OUT_A- (C-) | OUT_B+ (D+) | OUT_B- (D-) |
|-------|-------------|-------------|-------------|-------------|
| Step1 | ON | OFF | ON | OFF |
| Step2 | OFF | ON | ON | OFF |
| Step3 | OFF | ON | OFF | ON |
| Step4 | ON | OFF | OFF | ON |

<2-phase excitation in CCW>

| | OUT_A+ (C+) | OUT_A- (C-) | OUT_B+ (D+) | OUT_B- (D-) |
|-------|-------------|-------------|-------------|-------------|
| Step1 | ON | OFF | ON | OFF |
| Step2 | ON | OFF | OFF | ON |
| Step3 | OFF | ON | OFF | ON |
| Step4 | OFF | ON | ON | OFF |

<1-2-phase excitation in CW>

| | OUT_A+ (C+) | OUT_A- (C-) | OUT_B+ (D+) | OUT_B- (D-) |
|-------|-------------|-------------|-------------|-------------|
| Step1 | ON | OFF | ON | OFF |
| Step2 | OFF | OFF | ON | OFF |
| Step3 | OFF | ON | ON | OFF |
| Step4 | OFF | ON | OFF | OFF |
| Step5 | OFF | ON | OFF | ON |
| Step6 | OFF | OFF | OFF | ON |
| Step7 | ON | OFF | OFF | ON |
| Step8 | ON | OFF | OFF | OFF |

<1-2-phase excitation in CCW>

| | OUT_A+ (C+) | OUT_A- (C-) | OUT_B+ (D+) | OUT_B- (D-) |
|-------|-------------|-------------|-------------|-------------|
| Step1 | ON | OFF | ON | OFF |
| Step2 | ON | OFF | OFF | OFF |
| Step3 | ON | OFF | OFF | ON |
| Step4 | OFF | OFF | OFF | ON |
| Step5 | OFF | ON | OFF | ON |
| Step6 | OFF | ON | OFF | OFF |
| Step7 | OFF | ON | ON | OFF |
| Step8 | OFF | OFF | ON | OFF |

8. Pin function of serial/parallel conversion control I/F (Mode3)

8-1 Input interface (8bit shift register + 8bit storage register)

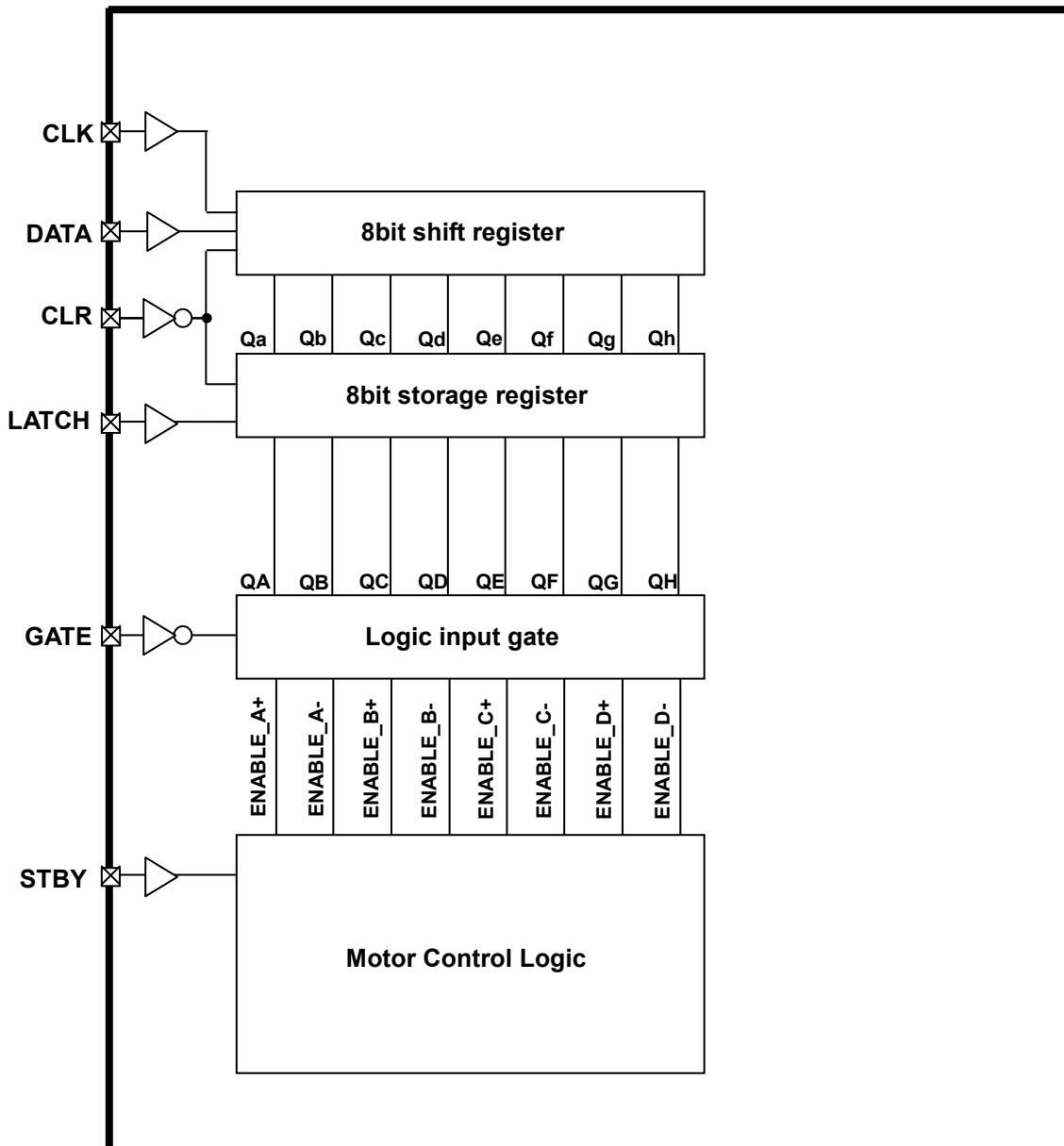

* Initial value for each logic pin when signal is not inputted

| | |
|-------|------|
| CLK | Low |
| DATA | Low |
| CLR | Low |
| LATCH | Low |
| GATE | High |
| STBY | Low |

Initial state for each logic pin when signal is not inputted is as follows.
 LATCH: Low=sift register/storage register: initial state
 GATE: High=ENABLE_X+ENABLE_X-=Disable * "X" of ENABLE_X stands for A, B, C, and D.
 STBY=Low: standby state

Timing chart of input signal (normal input)

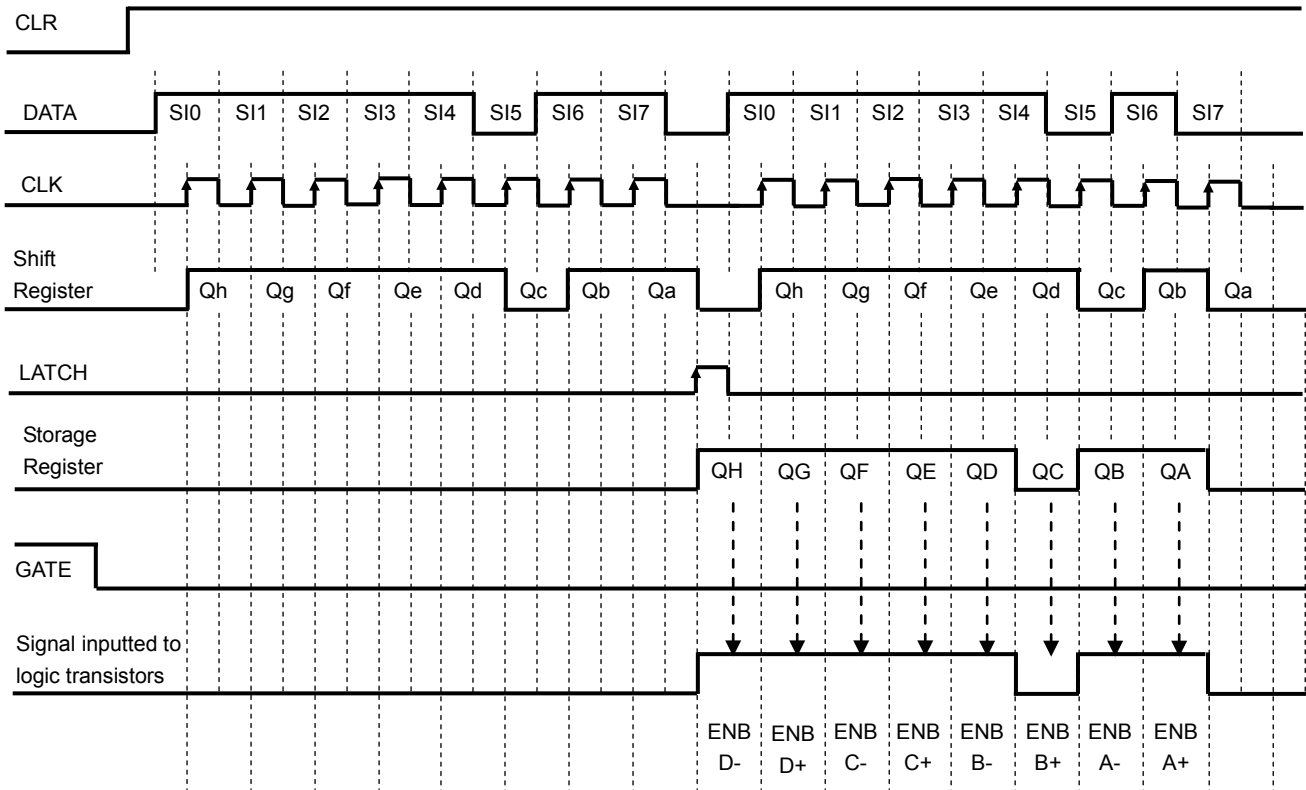

• Truth table

| Input | | | | | Function |
|-------|------|-----|-------|------|---|
| CLK | DATA | CLR | LATCH | GATE | |
| X | X | X | X | L | Data of ENABLE_X+ and ENABLE_X-: Not applicable |
| X | X | X | X | H | Data of ENABLE_X+ and ENABLE_X-: Applicable |
| X | X | L | X | X | Data stored in the storage register is cleared |
| L | ↑ | H | X | X | The first step of the shift register: 'L', Others: data of each prior step is stored. |
| H | ↑ | H | X | X | The first step of the shift register: 'H', Others: data of each prior step is stored. |
| X | ↓ | H | X | X | Shift register keeps prior state. |
| X | X | H | ↑ | X | Data of shift register is stored in the storage register. |
| X | X | H | ↓ | X | Storage register keeps prior state. |

Truth table: X=Don't care

* "X" of ENABLE_X stands for A, B, C, and D.

* Note: To operate logic output normally, SCK must be configured low in data transfer and complete.

• Description of logic signal

| Signal name | H | L | Notes |
|-------------|-------------------------|----------------------------------|--|
| ENABLE_X | Output ON | Output OFF | When ENABLE_x is set low, output of corresponded channel is turned off (Hi-z). |
| STBY | Motor operation: enable | Turn off all functions of the IC | When STBY is set L, motor output is turned off. (Motor cannot operate). |

8-2 Function of BRAKE (Full brake: All outputs are turned on forcedly)

(Enable in CLK mode and large mode)

When BRAKE mode is configured, all MOSFETs of OUTA+, A-, B+, and B- or OUTC+, C-, C+, and C- are turned on forcedly regardless of their output states.

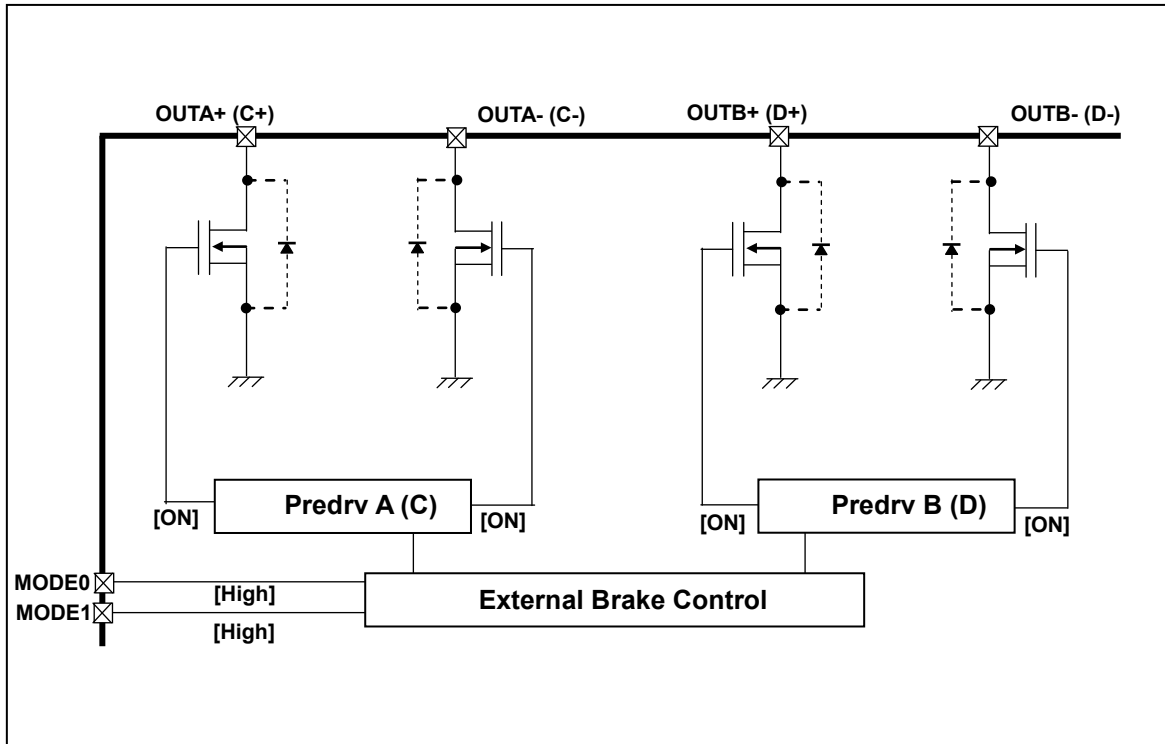

▪ **8-3 Function of ALM (output function of thermal shutdown alarm)**
 (Enable in serial/parallel conversion control I/F)

| ALM output | Function |
|------------|---|
| H | Normal operation |
| L | Thermal shutdown alarm function (Thermal_Alarm) |

ALM pin is a logic output pin of open drain type. It outputs high (pull-up voltage level) in normal state. When the temperature of the IC reaches specified threshold (Thermal_Alarm), low level (GND level) is outputted. Function of ALM is cleared automatically when the temperature of the IC falls 20°C (target value) lower than the threshold of Thermal Alarm.

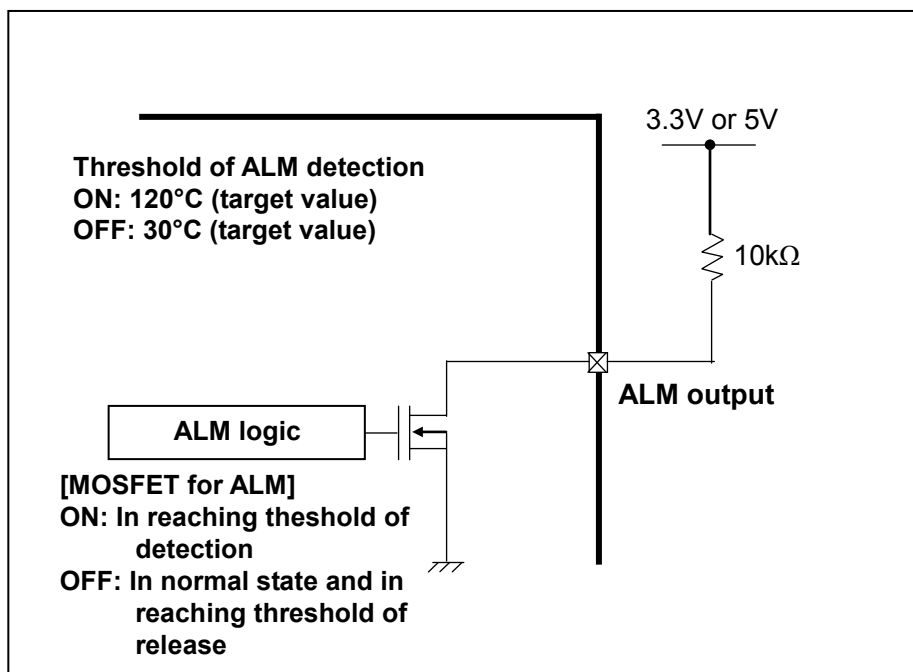

The equivalent circuit diagrams may be simplified or some parts of them may be omitted for explanatory purposes.

9. Function of Large mode I/F (Mode4)

9-1: Operation of Large mode

Large mode realizes 2-unit parallel drive.

It reduces actual Ron half and increases the current capability about 2 times. (As for actual values, refer to the section of electrical characteristics because the values including thermal capacity are specified.)

To use this mode, pins which have the same name should be short-circuited on the board for the power supply, GND, and output pins.

In this time, pay attention to wire on the board to average the impedance balance because if impedance balance is not averaged for each pin, the current is biased to one of pins.

9-2: Pin connection in Large mode

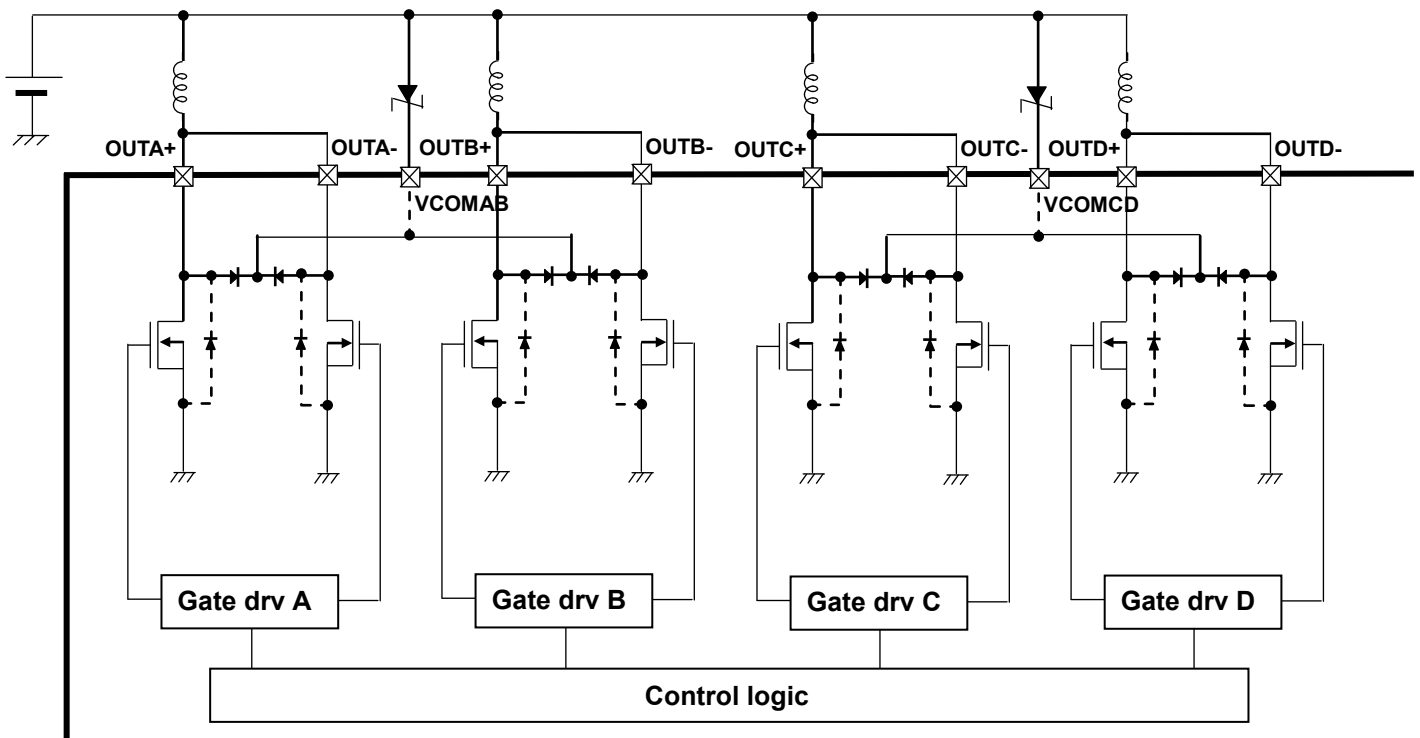

9-3. Function of CLK

The electrical angle gains one angle for every CLK. The signal is reflected at the up edge.

| CLK | Function |
|-----|---------------------------------|
| ↑ | To the next step at the up edge |
| ↓ | - (Prior state is kept) |

9-4. Function of ENABLE

In driving stepping motor, it configures ON and OFF of the current. OFF mode (High impedance: Z) and the operation mode of the motor are switched by controlling this pin. In turning on or turning off the power supply, this pin must be fixed low.

| ENABLE | Function |
|--------|--|
| H | Output transistor is ON (Normal operation) |
| L | Output transistor is OFF (High impedance: Z) |

9-5. Function of CW/CCW and output pin

It switches the rotating direction of the stepping motor.
 CW: The current of phase AB is outputted 90°ahead of phase CD.
 CCW: The current of phase CD is outputted 90°ahead of phase AB.

| CW/CCW | Input function |
|--------|------------------------|
| H | Forward rotating (CW) |
| L | Reverse rotating (CCW) |

X: Don't care

9-6. Function of RESET

| RESET input | Input function |
|-------------|------------------------|
| H | RESET electrical angle |
| L | Normal operation |

The current of each phase in RESET mode is as follows. (MO_OUT pin: Low)

The function of this pin synchronizes with AB and CD. So, the electrical angles of AB and CD are initialized by this pin at the same timing.

| Excitation mode | OUT_AB+ | OUT_AB- | OUT_CD+ | OUT_CD- |
|----------------------|---------|---------|---------|---------|
| 2-phase excitation | ON | OFF | ON | OFF |
| 1-2-phase excitation | ON | OFF | ON | OFF |

9-7. Function of excitation setting

| DMODE1 | DMODE2 | Function |
|--------|--------|---|
| L | L | STANDBY MODE Turn off output transistor, 2-phase excitation mode |
| L | H | 2-phase excitation |
| H | L | 1-2-excitation |
| H | H | BREAK mode (turn on all steps of output transistors) |

It is recommended to change DMODE1 and 2 after RESET is configured low in the initial state (MO_OUT = Low)

<2-phase excitation CW>

| | OUT_AB+ | OUT_AB- | OUT_CD+ | OUT_CD- |
|-------|---------|---------|---------|---------|
| Step1 | ON | OFF | ON | OFF |
| Step2 | OFF | ON | ON | OFF |
| Step3 | OFF | ON | OFF | ON |
| Step4 | ON | OFF | OFF | ON |

<2-phase excitation CCW>

| | OUT_AB+ | OUT_AB- | OUT_CD+ | OUT_CD- |
|-------|---------|---------|---------|---------|
| Step1 | ON | OFF | ON | OFF |
| Step2 | ON | OFF | OFF | ON |
| Step3 | OFF | ON | OFF | ON |
| Step4 | OFF | ON | ON | OFF |

<1-2-phase excitation CW>

| | OUT_AB+ | OUT_AB- | OUT_CD+ | OUT_CD- |
|-------|---------|---------|---------|---------|
| Step1 | ON | OFF | ON | OFF |
| Step2 | OFF | OFF | ON | OFF |
| Step3 | OFF | ON | ON | OFF |
| Step4 | OFF | ON | OFF | OFF |
| Step5 | OFF | ON | OFF | ON |
| Step6 | OFF | OFF | OFF | ON |
| Step7 | ON | OFF | OFF | ON |
| Step8 | ON | OFF | OFF | OFF |

<1-2-phase excitation CCW>

| | OUT_AB+ | OUT_AB- | OUT_CD+ | OUT_CD- |
|-------|---------|---------|---------|---------|
| Step1 | ON | OFF | ON | OFF |
| Step2 | ON | OFF | OFF | OFF |
| Step3 | ON | OFF | OFF | ON |
| Step4 | OFF | OFF | OFF | ON |
| Step5 | OFF | ON | OFF | ON |
| Step6 | OFF | ON | OFF | OFF |
| Step7 | OFF | ON | ON | OFF |
| Step8 | OFF | OFF | ON | OFF |

10. Absolute maximum ratings (Ta=25°C)

| Characteristics | Symbol | Rating | Unit |
|---|---------------|------------|------|
| Motor power supply VM | VM (max) | 80 | V |
| Motor output voltage | VOOUT (max) | 80 | V |
| Motor output current | IOOUT_S (max) | 1.5 | A |
| | IOOUT_L (max) | 3.0 | |
| Internal logic power supply | VCC (max) | 6.0 | V |
| Logic input voltage | VIN (H)(max) | 6.0 | V |
| | VIN (L)(min) | -0.4 | V |
| Open drain output pin (MO,ERR,ALM) voltage range | Vod (max) | 6.0 | V |
| Open drain output pin (MO,ERR,ALM) inflow current range | Iod (max) | 20 | mA |
| Power dissipation (Note) | PD | 1.3 | W |
| Operating temperature | Topr | -20 to 85 | °C |
| Storage temperature | Tstg | -55 to 150 | °C |
| Junction temperature | Tj (max) | 150 | °C |

Note: Monolithic. When the temperature (Ta) exceeds 25°C, derate the value by 10.4mW/°C.

Ta: Ambient temperature of the IC

Topr: Ambient temperature of the IC under operation.

Tj: Chip temperature of the IC under operation. The maximum of Tj is limited by the temperature of TSD (thermal shutdown circuit). It is recommended to design the IC by considering the maximum of the usage current of 120°C.

Absolute maximum ratings

The absolute maximum ratings of a semiconductor device are a set of ratings that must not be exceeded, even for a moment. Do not exceed any of these ratings. Exceeding the rating (s) may cause device breakdown, damage or deterioration, and may result in injury by explosion or combustion. The value of even one parameter of the absolute maximum ratings should not be exceeded under any circumstances. The device does not have overvoltage detection circuit. Therefore, the device is damaged if a voltage exceeding its rated maximum is applied. All voltage ratings, including supply voltages, must always be followed. The other notes and considerations described later should also be referred to.

■ (For reference) Relation of power dissipation and ambient temperature

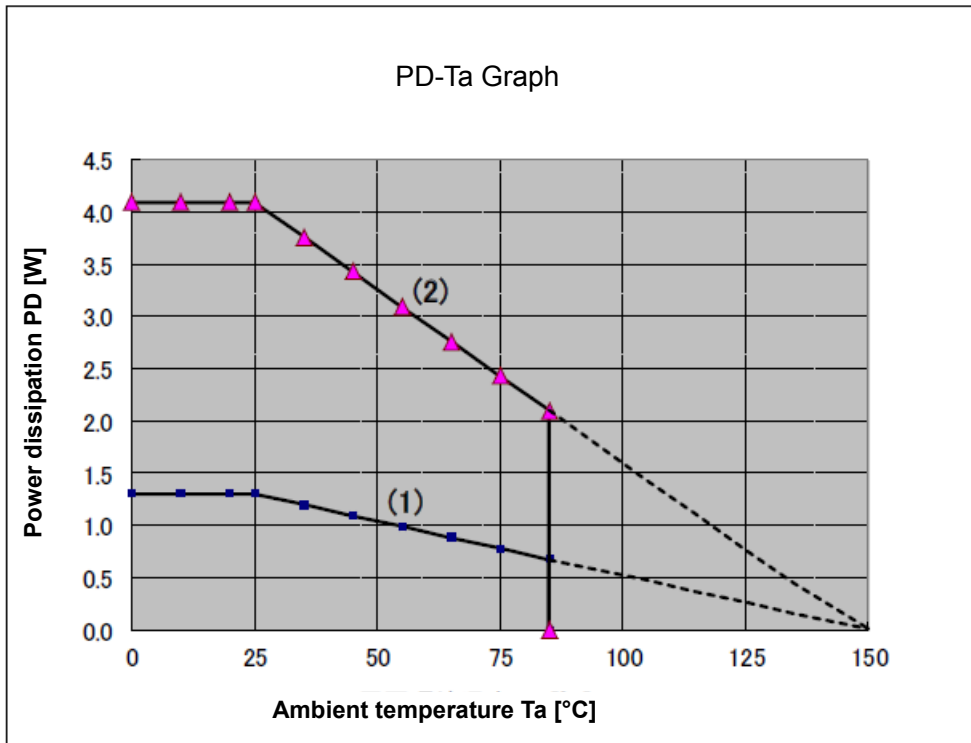

- (1) Monolithic
- (2) When mounted on a 4 layer glass epoxy board (power dissipation example of Rth(j-a)=25°C/W (when mounted); dependent of board and mount condition.)

11. Operation ranges

| Characteristics | Symbol | Test condition | Min | Typ. | Max | Unit |
|-------------------------------------|-------------|---------------------------|------|------|------|------|
| Motor power supply VM | VM | | 10 | 24 | 60 | V |
| Motor output voltage | VOUT | Connecting to zener (24V) | 10 | 48 | 60 | V |
| Motor output current | IOUT_S | Ta=25°C per phase | - | 1.0 | 1.5 | A |
| | IOUT_L | In large mode | - | 2.0 | 3.0 | |
| Internal logic power supply | VCC | - | 4.75 | 5.0 | 5.25 | V |
| Logic input voltage | VIN (H) | Logic input high level | 2.0 | - | 5.5 | V |
| | VIN (L) | Logic input low level | 0 | - | 0.8 | V |
| Open drain pin voltage range | Vod (range) | ERR,ALM pin | 3.0 | - | 5.5 | V |
| Open drain pin inflow current range | Iod (range) | ERR,ALM pin | - | - | 10 | mA |

(Note): Please use the device with extra margin regarding the absolute maximum ratings.

12. Electrical characteristics

12-1. DC electrical specifications 1 (Ta=25°C, VM=24V, unless specified otherwise)

| Characteristics | | Symbol | Test condition | Min | Typ. | Max | Unit |
|--|------|-----------|---|-----|------|-----|------|
| Logic input voltage | | VIH | Logic input voltage High level | 2.0 | - | 5.5 | V |
| | | VIL | Logic input voltage Low level | GND | - | 0.8 | V |
| Input hysteresis | | VIN (HYS) | (Note 1) | 100 | - | 300 | mV |
| Logic input current | High | IIN (H) | Logic input voltage High level (VIN=3.3V) | - | 33 | 55 | μA |
| | Low | IIN (L) | Logic input voltage Low level | - | - | 1 | μA |
| IM consumption current | | IM1 | Output pins: open, VIN=VIL, Standby mode | - | 0.7 | 1.0 | mA |
| | | IM2 | Output pins: open, Normal operation Motor output steps: no operation | - | 1.3 | 2.0 | mA |
| Open drain logic output pin voltage | | VOL | IOL=5mA (output pins: Low) | | | 0.5 | V |
| Regenerative diode Forward voltage | | VFN | VM=24V, IOU=1.5A, Tj=25°C | | 1.2 | | V |
| Output transistor Drain-Source On-resistance | | RON (D-S) | IOU=1.5A Tj=25°C | - | 0.5 | 0.7 | Ω |

(Note 1): VIN (H) is defined as the VIN voltage that causes the outputs to change when the voltage of the test pin is gradually raised from 0 V. VIN (L) is defined as the VIN voltage that causes the outputs to change when the voltage of the pin is then gradually lowered. The difference between VIN (L) and VIN (H) is defined as the input hysteresis.

12-2. DC electrical specifications 2 (Ta=25°C, VM=24V, unless specified otherwise)

| Characteristics | Symbol | Test condition | Min | Typ. | Max | Unit |
|--|--------|----------------|-----|------|-----|------|
| Temperature threshold of thermal shutdown detection (TSD) (Note 1) | TjTSD | - | 140 | 160 | 170 | °C |
| VM recovery voltage | VMR | | 7.0 | 8.0 | 9.0 | V |
| Over current detection (ISD) threshold (Note 2) | ISD | Single | 1.6 | 3.0 | 4.0 | A |
| | | Large | 3.2 | 6.0 | 8.0 | |

Note1) About Thermal shutdown (TSD)

When the junction temperature of the IC reaches the TSD threshold, the TSD circuit operates and turns off the output transistors. Noise rejection blanking time is provided to avoid misdetection by switching. (As for details, refer to the section of "Blanking time of TSD".) The IC drives in the standby mode while TSD operates. Once the TSD circuit is triggered, the detect latch signal can be cleared by reasserting the VM power supply, or setting the device to standby mode. The TSD circuit is a backup function to detect a thermal error, therefore it is not recommended to be used aggressively.

Note2) About Over-current detection (ISD)

When the output current reaches the threshold, the ISD circuit operates and turns off the output transistors. Noise rejection blanking time is provided to avoid misdetection by switching. (As for details, refer to the section of "Blanking time of ISD".) While ISD operates, the IC drives in the standby mode. After ISD circuit is triggered, the detect latch signal can be cleared by reasserting the VM power supply, or setting the device to standby mode.

Back-EMF

While a motor is rotating, there is a timing at which power is fed back to the power supply. At that timing, the motor current recirculates back to the power supply due to the effect of the motor back-EMF. If the power supply does not have enough sink capability, the power supply and output pins of the device might rise above the rated voltages. The magnitude of the motor back-EMF varies with usage conditions and motor characteristics. It must be fully verified that there is no risk that the device or other components will be damaged or fail due to the motor back-EMF.

Cautions on Overcurrent Shutdown (ISD) and Thermal Shutdown (TSD)

The ISD and TSD circuits are only intended to provide temporary protection against irregular conditions such as an output short-circuits; they do not necessarily guarantee the complete IC safety. If the device is used beyond the specified operating ranges, these circuits may not operate properly: then the device may be damaged due to an output short-circuit. The ISD circuit is only intended to provide a temporary protection against an output short-circuit. If such condition persists for a long time, the device may be damaged due to overstress. Overcurrent conditions must be removed immediately by external hardware.

IC Mounting

Do not insert devices incorrectly or in the wrong orientation. Otherwise, it may cause breakdown, damage and/or deterioration of the device.

12-3. AC electrical specifications (Ta=25°C, VM=24V, unless specified otherwise)

| Characteristics | Symbol | Test condition | Min | Typ. | Max | Unit |
|--|-------------|----------------------------|-----|------|-----|------|
| Logic input frequency | fLogic | | 1.0 | - | 150 | kHz |
| Minimum clock pulse width | twp | - | 700 | - | - | ns |
| | twl | - | 700 | - | - | ns |
| Output transistor Switching characteristics | tr | - | 0.2 | 0.25 | 0.3 | μs |
| | tf | - | 0.2 | 0.25 | 0.3 | μs |
| | tpLH (CLK) | Between "Logic" and "OUT" | - | 1.2 | - | μs |
| | tpHL (CLK) | | - | 1.2 | - | μs |
| Over current detection (ISD) masking time | tISD (Mask) | Internal oscillation: 4MHz | - | 2.0 | - | μs |
| Over current detection (ISD) operating time | tISD | | 2.0 | - | 4.0 | |
| Thermal shutdown detection (TSD) masking time | tTSD (Mask) | Internal oscillation: 4MHz | | 8.0 | | μs |

Timing chart: Switching characteristics of output transistors

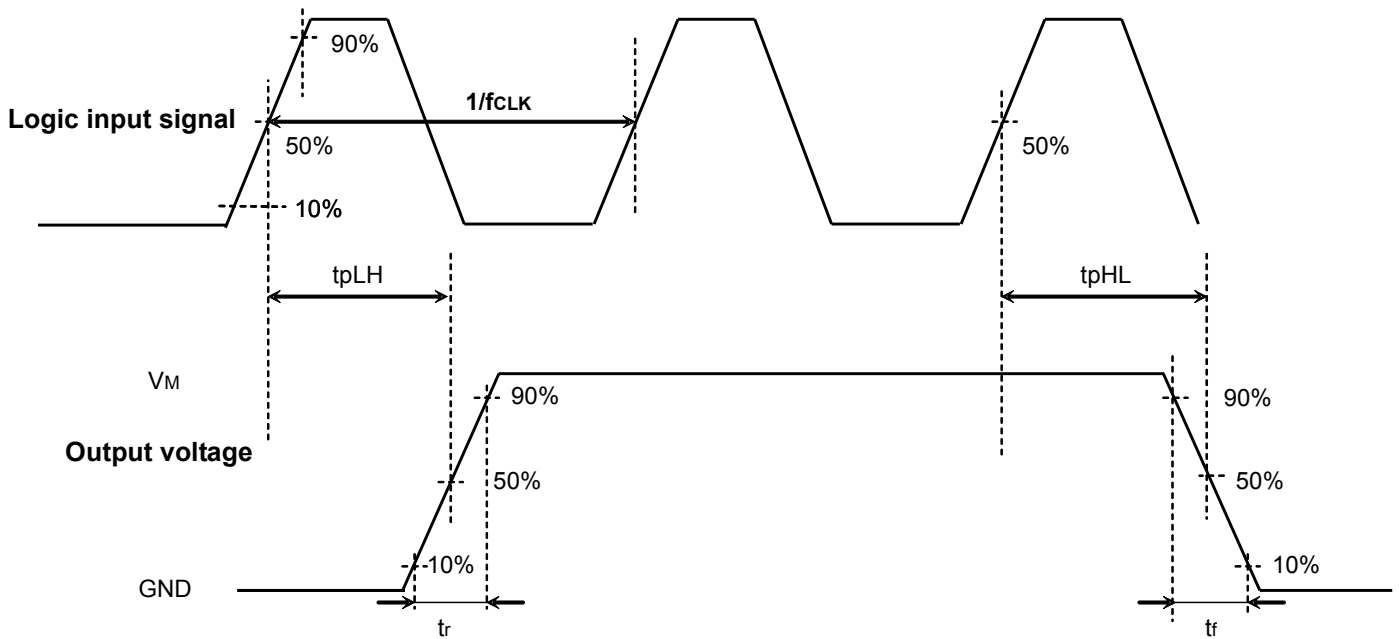

Figure 1 CLK input and switching characteristics of output transistors

Timing charts may be simplified for explanatory purposes.

12-4 AC electrical specifications [Serial/Parallel conversion]
(Ta = 25°C, VM = 24 V, 6.8 mH/5.7 Ω)

| Characteristics | Symbol | Electrical characteristics | Test condition | Min | Typ. | Max | Unit |
|---|--------|----------------------------|----------------|-----|------|-----|------|
| Minimum pulse width (SCK, RCK, and SI input signals) | tw (H) | AC | - | 250 | - | - | ns |
| | tw (L) | | - | 250 | - | - | ns |
| Minimum setting up time | tset1 | | CLR→CLK | 50 | - | - | ns |
| | tset2 | | DATA→CLK | 50 | - | - | ns |
| | tset3 | | CLK→LATCH | 50 | - | - | ns |
| Cycle time of minimum clock signal (SCK and RCK) | tcyc | | - | 500 | - | - | ns |
| Minimum hold time | thold1 | | CLK→DATA | 50 | - | - | ns |

Timing chart: Switching characteristics of output transistors

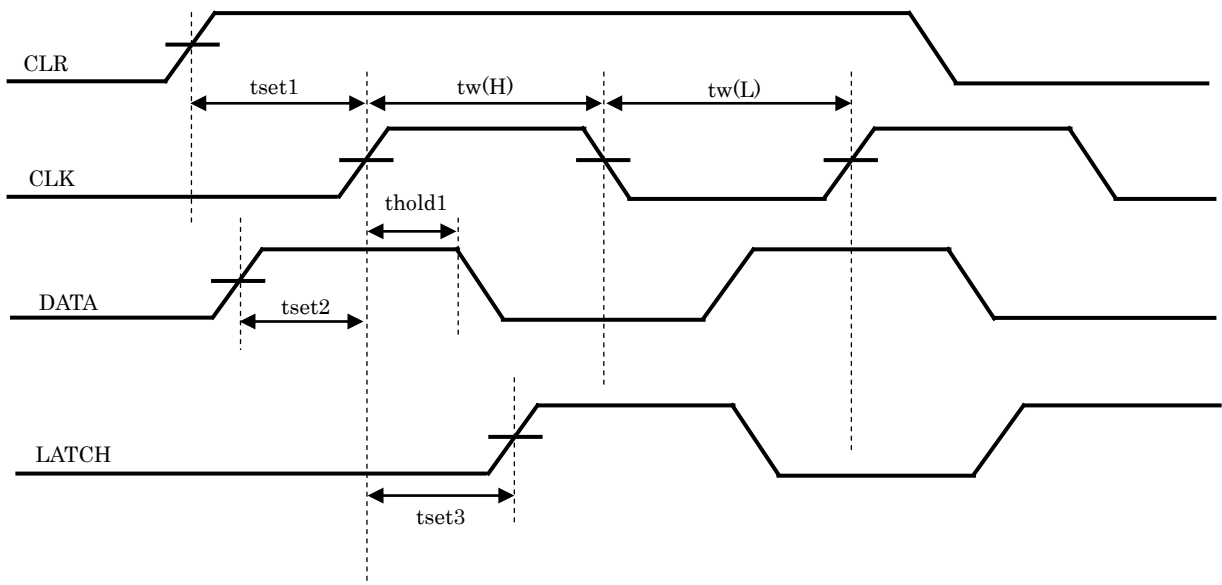

Timing charts may be simplified for explanatory purposes.

Power consumption of the IC

Power consumption of the IC is separated into two; consumed by output transistors and by logic transistors.

1. Power consumption of power transistors (when $R_{ON} (D-S) = 0.5 \Omega$)

Electrical power of output block is consumed by transistors.

Electrical power of the transistors in one motor drive is indicated as follows;

$$P (out) = 2 (\text{number of channels}) \times I_{out} (A)^2 \times R_{on} (\Omega) \dots\dots\dots (1)$$

When $R_{on} = 0.5 \Omega$ and $I_{out} = 1.0 A$,

$$P (out) = 2 (ch) \times 1.0(A)^2 \times 0.5 (\Omega) \dots\dots\dots (2)$$

$$= 1.0(W)$$

2. Power consumption of logic and IM system

It is calculated by separating the states into driving mode and turning off mode.

$$I (IM2) = 2 \text{ mA (max)}$$

Power consumption can be estimated from below formula.

$$P (IM) = 24 (V) \times 0.002 (A) \dots\dots\dots (3)$$

$$= 0.048 (W)$$

3. Power consumption

Whole power consumption (P) is calculated from the result of the calculations of (2) and (3).

$$P = P (out) + P (IM) = 1.048 (W)$$

As for thermal design for the board, take enough margin to design after evaluating the IC with the actual board.

Excitation drive (CW)

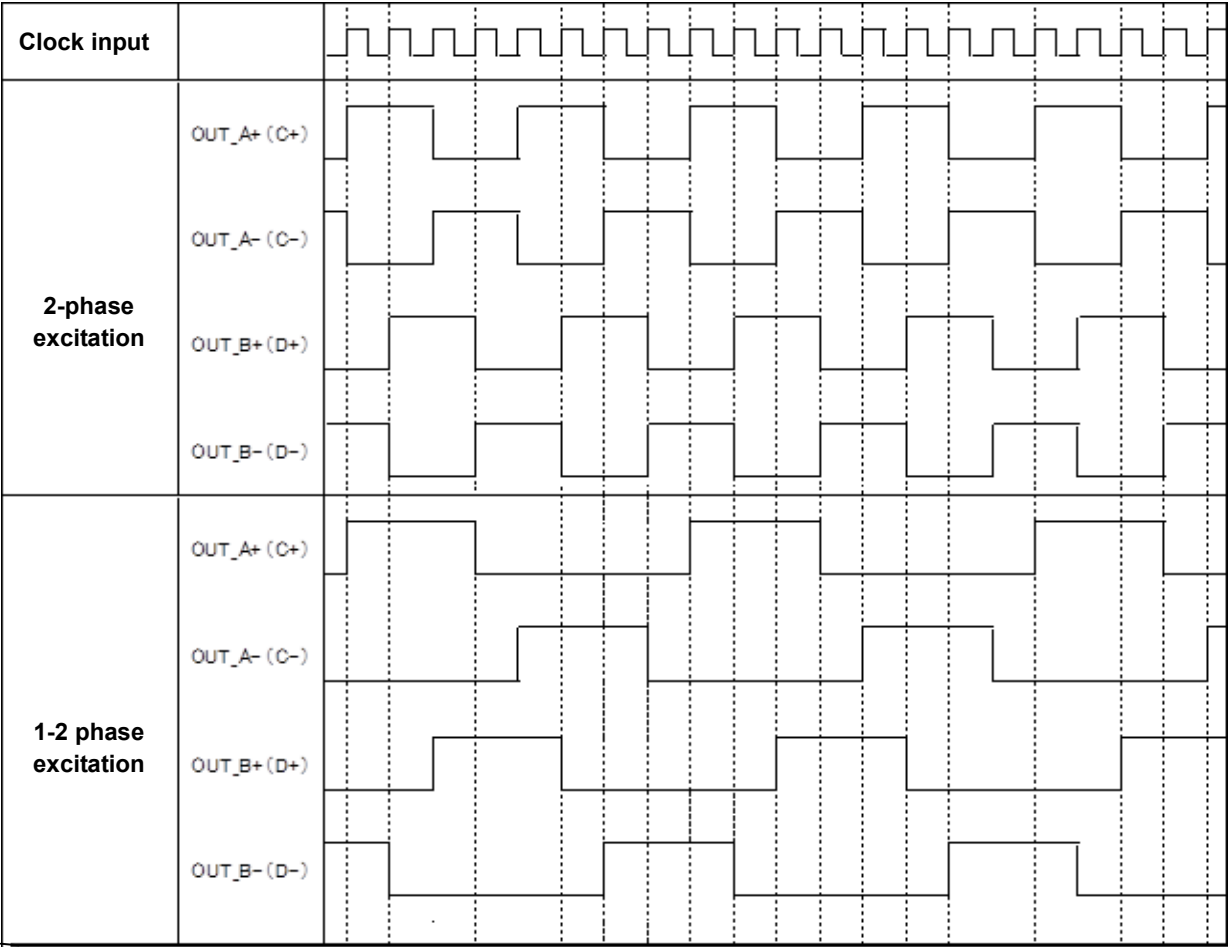

Timing charts may be simplified for explanatory purposes.

Notes on Contents

Block Diagrams

Some of the functional blocks, circuits, or constants in the block diagram may be omitted or simplified for explanatory purposes.

Equivalent Circuits

The equivalent circuit diagrams may be simplified or some parts of them may be omitted for explanatory purposes.

Timing Charts

Timing charts may be simplified for explanatory purposes.

Application Circuits

The application circuits shown in this document are provided for reference purposes only. Thorough evaluation is required, especially at the mass-production design stage.

Toshiba does not grant any license to any industrial property rights by providing these examples of application circuits.

Test Circuits

Components in the test circuits are used only to obtain and confirm the device characteristics. These components and circuits are not guaranteed to prevent malfunction or failure from occurring in the application equipment.

IC Usage Considerations

Notes on handling of ICs

- (1) The absolute maximum ratings of a semiconductor device are a set of ratings that must not be exceeded, even for a moment. Do not exceed any of these ratings. Exceeding the rating(s) may cause device breakdown, damage or deterioration, and may result in injury by explosion or combustion.
- (2) Use an appropriate power supply fuse to ensure that a large current does not continuously flow in the case of overcurrent and/or IC failure. The IC will fully break down when used under conditions that exceed its absolute maximum ratings, when the wiring is routed improperly or when an abnormal pulse noise occurs from the wiring or load, causing a large current to continuously flow and the breakdown can lead to smoke or ignition. To minimize the effects of the flow of a large current in the case of breakdown, appropriate settings, such as fuse capacity, fusing time and insertion circuit location, are required.
- (3) If your design includes an inductive load such as a motor coil, incorporate a protection circuit into the design to prevent device malfunction or breakdown caused by the current resulting from the inrush current at power ON or the negative current resulting from the back electromotive force at power OFF. IC breakdown may cause injury, smoke or ignition. Use a stable power supply with ICs with built-in protection functions. If the power supply is unstable, the protection function may not operate, causing IC breakdown. IC breakdown may cause injury, smoke or ignition.
- (4) Do not insert devices in the wrong orientation or incorrectly. Make sure that the positive and negative terminals of power supplies are connected properly. Otherwise, the current or power consumption may exceed the absolute maximum rating, and exceeding the rating(s) may cause device breakdown, damage or deterioration, and may result in injury by explosion or combustion. In addition, do not use any device inserted in the wrong orientation or incorrectly to which current is applied even just once.
- (5) Carefully select external components (such as inputs and negative feedback capacitors) and load components (such as speakers), for example, power amp and regulator. If there is a large amount of leakage current such as from input or negative feedback condenser, the IC output DC voltage will increase. If this output voltage is connected to a speaker with low input withstand voltage, overcurrent or IC failure may cause smoke or ignition. (The overcurrent may cause smoke or ignition from the IC itself.) In particular, please pay attention when using a Bridge Tied Load (BTL) connection-type IC that inputs output DC voltage to a speaker directly.

Points to remember on handling of ICs**Overcurrent detection Circuit**

Overcurrent detection circuits (referred to as current limiter circuits) do not necessarily protect ICs under all circumstances. If the overcurrent detection circuits operate against the overcurrent, clear the overcurrent status immediately.

Depending on the method of use and usage conditions, exceeding absolute maximum ratings may cause the overcurrent detection circuit to operate improperly or IC breakdown may occur before operation. In addition, depending on the method of use and usage conditions, if overcurrent continues to flow for a long time after operation, the IC may generate heat resulting in breakdown.

Thermal Shutdown Circuit

Thermal shutdown circuits do not necessarily protect ICs under all circumstances. If the thermal shutdown circuits operate against the over-temperature, clear the heat generation status immediately.

Depending on the method of use and usage conditions, exceeding absolute maximum ratings may cause the thermal shutdown circuit to operate improperly or IC breakdown to occur before operation.

Heat Radiation Design

When using an IC with large current flow such as power amp, regulator or driver, design the device so that heat is appropriately radiated, in order not to exceed the specified junction temperature (T_j) at any time or under any condition. These ICs generate heat even during normal use. An inadequate IC heat radiation design can lead to decrease in IC life, deterioration of IC characteristics or IC breakdown. In addition, when designing the device, take into consideration the effect of IC heat radiation with peripheral components.

Back-EMF

When a motor rotates in the reverse direction, stops or slows abruptly, current flows back to the motor's power supply owing to the effect of back-EMF. If the current sink capability of the power supply is small, the device's motor power supply and output pins might be exposed to conditions beyond the absolute maximum ratings. To avoid this problem, take the effect of back-EMF into consideration in system design.

RESTRICTIONS ON PRODUCT USE

- Toshiba Corporation, and its subsidiaries and affiliates (collectively "TOSHIBA"), reserve the right to make changes to the information in this document, and related hardware, software and systems (collectively "Product") without notice.
- This document and any information herein may not be reproduced without prior written permission from TOSHIBA. Even with TOSHIBA's written permission, reproduction is permissible only if reproduction is without alteration/omission.
- Though TOSHIBA works continually to improve Product's quality and reliability, Product can malfunction or fail. Customers are responsible for complying with safety standards and for providing adequate designs and safeguards for their hardware, software and systems which minimize risk and avoid situations in which a malfunction or failure of Product could cause loss of human life, bodily injury or damage to property, including data loss or corruption. Before customers use the Product, create designs including the Product, or incorporate the Product into their own applications, customers must also refer to and comply with (a) the latest versions of all relevant TOSHIBA information, including without limitation, this document, the specifications, the data sheets and application notes for Product and the precautions and conditions set forth in the "TOSHIBA Semiconductor Reliability Handbook" and (b) the instructions for the application with which the Product will be used with or for. Customers are solely responsible for all aspects of their own product design or applications, including but not limited to (a) determining the appropriateness of the use of this Product in such design or applications; (b) evaluating and determining the applicability of any information contained in this document, or in charts, diagrams, programs, algorithms, sample application circuits, or any other referenced documents; and (c) validating all operating parameters for such designs and applications. **TOSHIBA ASSUMES NO LIABILITY FOR CUSTOMERS' PRODUCT DESIGN OR APPLICATIONS.**
- **PRODUCT IS NEITHER INTENDED NOR WARRANTED FOR USE IN EQUIPMENTS OR SYSTEMS THAT REQUIRE EXTRAORDINARILY HIGH LEVELS OF QUALITY AND/OR RELIABILITY, AND/OR A MALFUNCTION OR FAILURE OF WHICH MAY CAUSE LOSS OF HUMAN LIFE, BODILY INJURY, SERIOUS PROPERTY DAMAGE AND/OR SERIOUS PUBLIC IMPACT ("UNINTENDED USE").** Except for specific applications as expressly stated in this document, Unintended Use includes, without limitation, equipment used in nuclear facilities, equipment used in the aerospace industry, medical equipment, equipment used for automobiles, trains, ships and other transportation, traffic signaling equipment, equipment used to control combustions or explosions, safety devices, elevators and escalators, devices related to electric power, and equipment used in finance-related fields. **IF YOU USE PRODUCT FOR UNINTENDED USE, TOSHIBA ASSUMES NO LIABILITY FOR PRODUCT.** For details, please contact your TOSHIBA sales representative.
- Do not disassemble, analyze, reverse-engineer, alter, modify, translate or copy Product, whether in whole or in part.
- Product shall not be used for or incorporated into any products or systems whose manufacture, use, or sale is prohibited under any applicable laws or regulations.
- The information contained herein is presented only as guidance for Product use. No responsibility is assumed by TOSHIBA for any infringement of patents or any other intellectual property rights of third parties that may result from the use of Product. No license to any intellectual property right is granted by this document, whether express or implied, by estoppel or otherwise.
- **ABSENT A WRITTEN SIGNED AGREEMENT, EXCEPT AS PROVIDED IN THE RELEVANT TERMS AND CONDITIONS OF SALE FOR PRODUCT, AND TO THE MAXIMUM EXTENT ALLOWABLE BY LAW, TOSHIBA (1) ASSUMES NO LIABILITY WHATSOEVER, INCLUDING WITHOUT LIMITATION, INDIRECT, CONSEQUENTIAL, SPECIAL, OR INCIDENTAL DAMAGES OR LOSS, INCLUDING WITHOUT LIMITATION, LOSS OF PROFITS, LOSS OF OPPORTUNITIES, BUSINESS INTERRUPTION AND LOSS OF DATA, AND (2) DISCLAIMS ANY AND ALL EXPRESS OR IMPLIED WARRANTIES AND CONDITIONS RELATED TO SALE, USE OF PRODUCT, OR INFORMATION, INCLUDING WARRANTIES OR CONDITIONS OF MERCHANTABILITY, FITNESS FOR A PARTICULAR PURPOSE, ACCURACY OF INFORMATION, OR NONINFRINGEMENT.**
- Do not use or otherwise make available Product or related software or technology for any military purposes, including without limitation, for the design, development, use, stockpiling or manufacturing of nuclear, chemical, or biological weapons or missile technology products (mass destruction weapons). Product and related software and technology may be controlled under the applicable export laws and regulations including, without limitation, the Japanese Foreign Exchange and Foreign Trade Law and the U.S. Export Administration Regulations. Export and re-export of Product or related software or technology are strictly prohibited except in compliance with all applicable export laws and regulations.
- Please contact your TOSHIBA sales representative for details as to environmental matters such as the RoHS compatibility of Product. Please use Product in compliance with all applicable laws and regulations that regulate the inclusion or use of controlled substances, including without limitation, the EU RoHS Directive. **TOSHIBA ASSUMES NO LIABILITY FOR DAMAGES OR LOSSES OCCURRING AS A RESULT OF NONCOMPLIANCE WITH APPLICABLE LAWS AND REGULATIONS.**

Mouser Electronics

Authorized Distributor

Click to View Pricing, Inventory, Delivery & Lifecycle Information:

[Toshiba:](#)

[TB67S158FTG,EL](#)



Компания «ЭлектроПласт» предлагает заключение долгосрочных отношений при поставках импортных электронных компонентов на взаимовыгодных условиях!

Наши преимущества:

- Оперативные поставки широкого спектра электронных компонентов отечественного и импортного производства напрямую от производителей и с крупнейших мировых складов;
- Поставка более 17-ти миллионов наименований электронных компонентов;
- Поставка сложных, дефицитных, либо снятых с производства позиций;
- Оперативные сроки поставки под заказ (от 5 рабочих дней);
- Экспресс доставка в любую точку России;
- Техническая поддержка проекта, помощь в подборе аналогов, поставка прототипов;
- Система менеджмента качества сертифицирована по Международному стандарту ISO 9001;
- Лицензия ФСБ на осуществление работ с использованием сведений, составляющих государственную тайну;
- Поставка специализированных компонентов (Xilinx, Altera, Analog Devices, Intersil, Interpoint, Microsemi, Aeroflex, Peregrine, Syfer, Eurofarad, Texas Instrument, Miteq, Cobham, E2V, MA-COM, Hittite, Mini-Circuits, General Dynamics и др.);

Помимо этого, одним из направлений компании «ЭлектроПласт» является направление «Источники питания». Мы предлагаем Вам помощь Конструкторского отдела:

- Подбор оптимального решения, техническое обоснование при выборе компонента;
- Подбор аналогов;
- Консультации по применению компонента;
- Поставка образцов и прототипов;
- Техническая поддержка проекта;
- Защита от снятия компонента с производства.



Как с нами связаться

Телефон: 8 (812) 309 58 32 (многоканальный)

Факс: 8 (812) 320-02-42

Электронная почта: org@eplast1.ru

Адрес: 198099, г. Санкт-Петербург, ул. Калинина, дом 2, корпус 4, литера А.