

# Small, Gauge Pressure Sensor

## SM5G-GG Series

### FEATURES

- Improved stability with integrated field shields
- Small SO8 surface-mount package
- 90 millivolt output
- Constant current or constant voltage drive
- Ported configuration
- Wide operating temperature range (-40° to +125°C)



### DESCRIPTION

The SM5G-GG Series is a small outline SO8 packaged pressure sensor that incorporates SMI's new SM30G MEMS piezoresistive pressure sensing die. The SM5G-GG Series has been optimized to provide the highest possible accuracy for a package of this size. Performance is achieved through careful resistor placement and mechanical configuration along with advanced MEMS processing.

The packaged sensor is intended for high volume applications where cost is a critical factor, such as industrial and medical products. Samples of the SM5G-GG Series are available as a gauge pressure sensors in several pressure ranges. It is designed to be surface-mounted on ceramic or PC board substrates by high-volume OEM manufacturers.

The SM5G-GG Series is in a ported package. It can be used to sense pressure in a manifold configuration with an O-ring seal.

The SM5G-GG Series is available in sticks or in tape & reel.

Industrial	Consumer	Medical
Handheld Meters	Sports Equipment	Wound Therapy
Pneumatic Gauges	Appliances	Health Monitoring
Pressure Switches		Blood Pressure
		Bioreactors

**ABSOLUTE MAXIMUM RATING TABLE**

All parameters are specified at  $V_{DD} = 5.00$  V DC SUPPLY at 25°C, unless otherwise noted.

No.	Characteristic	Symbol	Minimum	Typical	Maximum	Units
1	Supply Voltage <sup>(a)</sup>	$V_{DD}$	0.0		10	V
2	Operating Temperature Range	$T_{OP}$	-40		+125	°C
3	Storage Temperature Range	$T_{STG}$	-40	-	+125	°C

**Notes:**

- a. If driven with constant current, the maximum supply voltage must not exceed 10 V.

No.	Product	Operating Pressure	Proof Pressure ( $P_{PROOF}$ )	Burst Pressure ( $P_{BURST}$ )
4a	SM5G-005S	0-5 PSI	15 PSI	25 PSI
4b	SM5G-015S	0-15 PSI	45 PSI	75 PSI
4c	SM5G-030S <sup>(b)</sup>	0-30 PSI	TBD	TBD
4d	SM5G-080S <sup>(b)</sup>	0-80 PSI	TBD	TBD

**Notes:**

- b. This product is in development

**OPERATING CHARACTERISTICS TABLE**

All parameters are specified at  $V_{DD} = 5.0$  V DC SUPPLY at 25°C, unless otherwise noted.

No.	Characteristic		Symbol	Minimum	Typical	Maximum	Units
5	Span <sup>(c, d)</sup>	5, 15, 80 <sup>(b)</sup> PSI	$V_{SPAN}$	60	90	120	mV
		30 <sup>(b)</sup> PSI		55	80	105	mV
6	Zero Offset		$V_{ZERO}$	-25	10	45	mV
7	TC Span <sup>(c, e, f)</sup>		TCS	-0.240	-0.19	-0.155	%FS/°C
8	TC Zero Offset <sup>(c, e, f)</sup>		TCZ	-75	-	75	μV/°C
9	TC Resistance <sup>(c, e, f)</sup>		TCR	0.24	0.275	0.33	%R <sub>B</sub> /°C
10	Linearity <sup>(c, f)</sup>	5 PSI	NL	-0.35	-	0.35	%FS
		15, 30 <sup>(b)</sup> , 80 <sup>(b)</sup> PSI		-0.2	-	0.2	
11	Bridge Resistance		$R_B$	4.0	5.0	6.0	kOhm
12	Pressure Hysteresis <sup>(g)</sup>		Phys		0.1		%FS
13	Thermal Hysteresis <sup>(h)</sup>		Thys		0.15		%FS

**Notes:**

- b. This product is in development.
- c. Tested on a sample basis.
- d. The device can only be driven with the supply voltage connected to the pins as shown.
- e. Determined by measurements taken at -40°C and 125°C.
- f. Defined using best fit straight line.
- g. Pressure hysteresis describes a phenomenon whereby the same applied pressure results in different output signals, depending upon whether the pressure is approached from a lower or higher pressure. The values shown represent the maximum values over the specified operating pressure and temperature range.
- h. Temperature hysteresis describes a phenomenon whereby the same applied temperature results in different output signals depending upon whether the temperature is approached from a lower or higher temperature. The values shown represent the maximum change of zero offset at 25°C when the device is cycled over the specified operating temperature range.

Diagrams & Dimensions

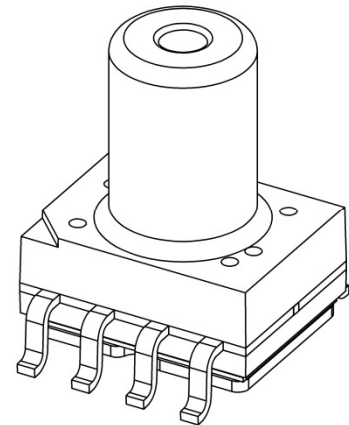
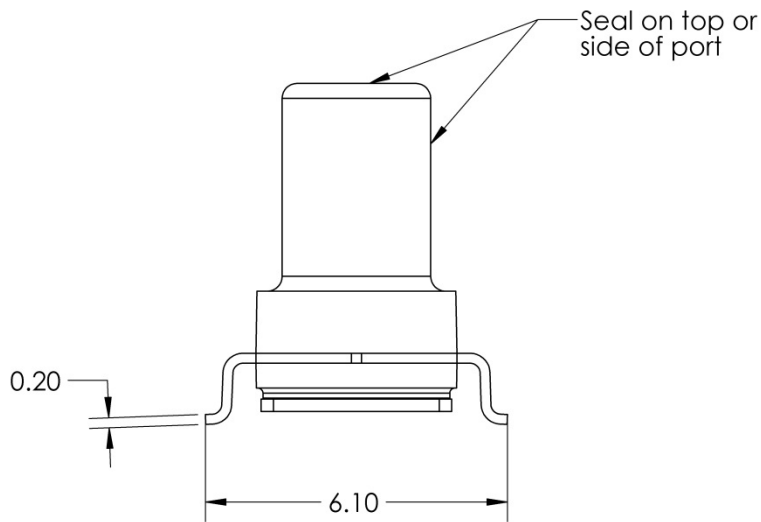
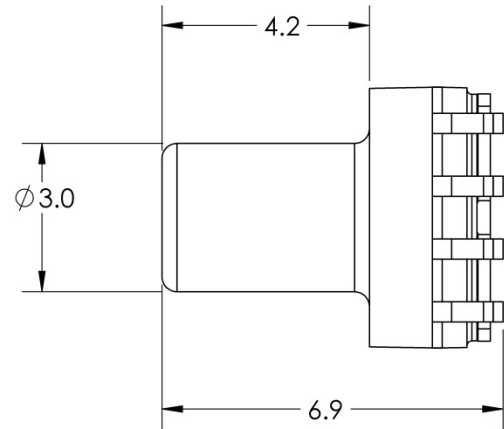
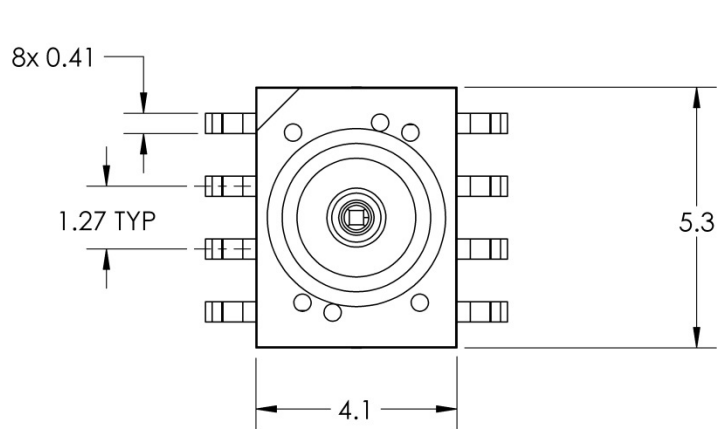

- All dimensions are for reference only
- All dimensions are in mm

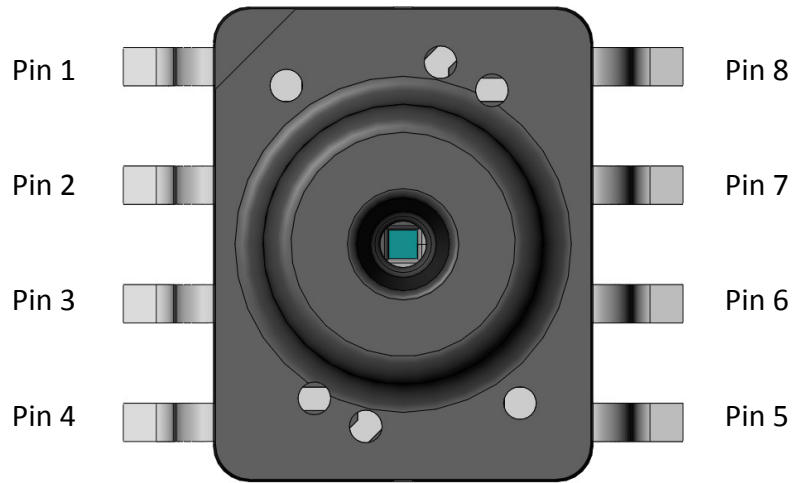

Pin-Out	PIN	Description
	1	NC
	2	+Sig
	3	NC
	4	Gnd
	5	NC
	6	-Sig
	7	NC
	8	+Vexc

Typical Operation			
Pin No.	Description	Type	Value
2	+Sig	Analog Out	-
4	Gnd	Gnd	0 V
6	-Sig	Analog Out	-
8	+Vexc	Power	+5 V

**Ordering Information**

Order Code	Pressure Type	Full-Scale Pressure Range	Cap Configuration	Shipping Configuration
SM5G-GGG-T-005S-000	Gauge	5 PSI	Port	Sticks or Tape & Reel
SM5G-GGG-T-015S-000		15 PSI		

**Part Number Legend**

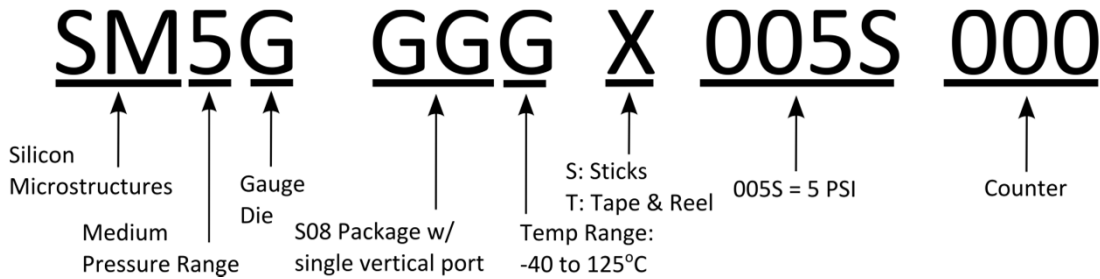

**Qualification Standards**

- REACH compliant
- RoHS compliant
- PFOS/PFOA compliant
- For qualification specifications please contact Sales at sales@si-micro.com



## Silicon Microstructures Warranty and Disclaimer:

Silicon Microstructures, Inc. reserves the right to make changes without further notice to any products herein and to amend the contents of this data sheet at any time and at its sole discretion.

Information in this document is provided solely to enable software and system implementers to use Silicon Microstructures, Inc. products and/or services. No express or implied copyright licenses are granted hereunder to design or fabricate any silicon-based microstructures based on the information in this document.

Silicon Microstructures, Inc. makes no warranty, representation, or guarantee regarding the suitability of its products for any particular purpose, nor does Silicon Microstructures, Inc. assume any liability arising out of the application or use of any product or silicon-based microstructure, and specifically disclaims any and all liability, including without limitation consequential or incidental damages. "Typical" parameters which may be provided in Silicon Microstructure's data sheets and/or specifications can and do vary in different applications and actual performance may vary over time. All operating parameters, including "Typicals", must be validated for each customer application by customer's technical experts. Silicon Microstructures, Inc. does not convey any license under its patent rights nor the rights of others. Silicon Microstructures, Inc. makes no representation that the circuits are free of patent infringement. Silicon Microstructures, Inc. products are not designed, intended, or authorized for use as components in systems intended for surgical implant into the body, or other applications intended to support or sustain life, or for any other application in which the failure of the Silicon Microstructures, Inc. product could create a situation where personal injury or death may occur. Should Buyer purchase or use Silicon Microstructures, Inc. products for any such unintended or unauthorized application, Buyer shall indemnify and hold Silicon Microstructures, Inc. and its officers, employees, subsidiaries, affiliates, and distributors harmless against all claims, costs, damages, and expenses, and reasonable attorney fees arising out of, directly or indirectly, any claim of personal injury or death associated with such unintended or unauthorized use, even if such claim alleges that Silicon Microstructures, Inc. was negligent regarding the design or manufacture of the part.

Silicon Microstructures, Inc. warrants goods of its manufacture as being free of defective materials and faulty workmanship. Silicon Microstructures, Inc. standard product warranty applies unless agreed to otherwise by Silicon Microstructures, Inc. in writing; please refer to your order acknowledgement or contact Silicon Microstructures, Inc. directly for specific warranty details. If warranted goods are returned to Silicon Microstructures, Inc. during the period of coverage, Silicon Microstructures, Inc. will repair or replace, at its option, without charge those items it finds defective. The foregoing is buyer's sole remedy and is in lieu of all warranties, expressed or implied, including those of merchantability and fitness for a particular purpose. In no event shall Silicon Microstructures, Inc. be liable for consequential, special, or indirect damages.

While Silicon Microstructures, Inc. provides application assistance personally, through its literature and the Silicon Microstructures, Inc. website, it is up to the customer to determine the suitability of the product for its specific application. The information supplied by Silicon Microstructures, Inc. is believed to be accurate and reliable as of this printing. However, Silicon Microstructures, Inc. assumes no responsibility for its use. Silicon Microstructures, Inc. assumes no responsibility for any inaccuracies and/or errors in this publication and reserves the right to make changes without further notice to any products or specifications herein

Silicon Microstructures, Inc.™ and the Silicon Microstructures, Inc. logo are trademarks of Silicon Microstructures, Inc. All other service or product names are the property of their respective owners.

© Silicon Microstructures, Inc. 2001-2016. All rights reserved.



Компания «ЭлектроПласт» предлагает заключение долгосрочных отношений при поставках импортных электронных компонентов на взаимовыгодных условиях!

Наши преимущества:

- Оперативные поставки широкого спектра электронных компонентов отечественного и импортного производства напрямую от производителей и с крупнейших мировых складов;
- Поставка более 17-ти миллионов наименований электронных компонентов;
- Поставка сложных, дефицитных, либо снятых с производства позиций;
- Оперативные сроки поставки под заказ (от 5 рабочих дней);
- Экспресс доставка в любую точку России;
- Техническая поддержка проекта, помощь в подборе аналогов, поставка прототипов;
- Система менеджмента качества сертифицирована по Международному стандарту ISO 9001;
- Лицензия ФСБ на осуществление работ с использованием сведений, составляющих государственную тайну;
- Поставка специализированных компонентов (Xilinx, Altera, Analog Devices, Intersil, Interpoint, Microsemi, Aeroflex, Peregrine, Syfer, Eurofarad, Texas Instrument, Miteq, Cobham, E2V, MA-COM, Hittite, Mini-Circuits, General Dynamics и др.);

Помимо этого, одним из направлений компании «ЭлектроПласт» является направление «Источники питания». Мы предлагаем Вам помощь Конструкторского отдела:

- Подбор оптимального решения, техническое обоснование при выборе компонента;
- Подбор аналогов;
- Консультации по применению компонента;
- Поставка образцов и прототипов;
- Техническая поддержка проекта;
- Защита от снятия компонента с производства.



#### Как с нами связаться

**Телефон:** 8 (812) 309 58 32 (многоканальный)

**Факс:** 8 (812) 320-02-42

**Электронная почта:** [org@eplast1.ru](mailto:org@eplast1.ru)

**Адрес:** 198099, г. Санкт-Петербург, ул. Калинина, дом 2, корпус 4, литера А.