



# R2005350L

## CATV Reverse Hybrid 200MHz 35dB

### Product Description

The R2005350L is a Hybrid Reverse amplifier. The part employs a Silicon die and is operated from 5 MHz to 200 MHz or 210 MHz. It provides excellent linearity and superior return loss performance with low noise and optimal reliability.



Package: SOT-115J

### Functional Block Diagram

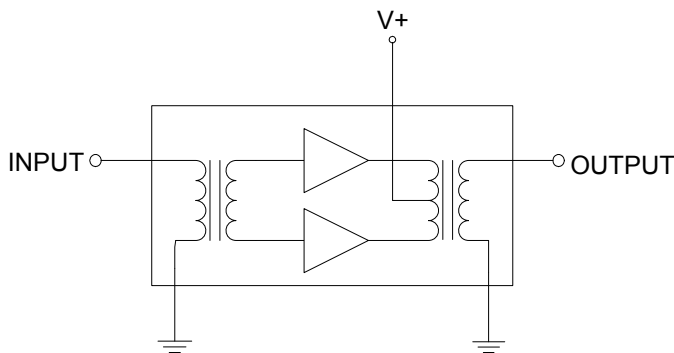

### Product Features

- Excellent Linearity
- Superior Return Loss Performance
- Extremely Low Distortion
- Optimal Reliability
- Low Noise
- Unconditionally Stable Under all Terminations
- 35.3 dB Typ. Gain at 210 MHz
- 160 mA Max. at 24 VDC

### Applications

- 5–200 MHz CATV Amplifier for Reverse Channel Systems

### Ordering Information

Part No.	Description
R2005350L	Box with 50 pcs

## R2005350L Absolute Maximum Ratings

Parameter	Value / Range
RF Input Voltage (single tone)	65 dBmV
DC Supply over-voltage (5 minutes)	+30 V
Storage Temperature	-40 to 100 °C
Operating Mounting Base Temperature	-30 to 100 °C

Operation of this device outside the parameter ranges given above may cause permanent damage.

## Electrical Specifications

Parameter	Test Conditions: V+=24V, T <sub>MB</sub> =30°C, Z <sub>S</sub> =Z <sub>L</sub> =75Ω	Min	Typ	Max	Unit
Operational Frequency Range	–	5	–	210	MHz
Gain	f <sub>o</sub> = 5 MHz	34.5	35.1	35.5	dB
Gain	f <sub>o</sub> = 200 MHz	34.5	35.3	36.0	
Gain	f <sub>o</sub> = 210 MHz	34.5	35.3	36.0	
Gain Slope	f <sub>o</sub> = 5 to 200 MHz <sup>[1]</sup>	-0.2	0.2	0.5	
Gain Slope	f <sub>o</sub> = 5 to 210 MHz <sup>[1]</sup>	-0.2	0.2	0.5	
Gain Flatness	f <sub>o</sub> = 5 to 200 MHz	-0.1		+0.5	
Gain Flatness	f <sub>o</sub> = 5 to 210 MHz	-0.1		+0.5	
Input Return Loss	f <sub>o</sub> = 5 to 200 MHz	20.0		–	
	f <sub>o</sub> = 200 to 210 MHz	20.0		–	
Output Return Loss	f <sub>o</sub> = 5 to 200 MHz	20.0		–	dB
	f <sub>o</sub> = 200 to 210 MHz	20.0		–	
Reverse Isolation	f <sub>o</sub> = 5 to 200 MHz			-42.0	dB
	f <sub>o</sub> = 200 to 210 MHz			-42.0	
Noise Figure	f <sub>o</sub> = 200 MHz	–	4.6	5.0	dB
	f <sub>o</sub> = 210 MHz	–	4.7	5.0	
IDC			157	160	mA
CTB				-72	dBc
XMOD	V <sub>O</sub> = 50.0dBmV, 7 channels flat <sup>[2]</sup>			-64	dBc
CSO				-72	dBc
CTB				-57	dBc
XMOD	V <sub>O</sub> = 50.0dBmV, 28 channels flat <sup>[3]</sup>			-50	dBc
CSO				-66	dBc
d2	<sup>[4]</sup>			-70	dBc
Vo	D <sub>IM</sub> = -60dB <sup>[5]</sup>	62			dBmV

- The slope is defined as the difference between the gain at the start frequency and the gain at the stop frequency.
- 7 analog channels, NTSC frequency raster: T7-T13 (7.00MHz to 43.00MHz), +50dBmV flat output level.
- 28 analog channels, NTSC frequency raster: T7-T13 plus 2-6 (55.25MHz to 83.25MHz) and A2-11 (109.25MHz to 199.25MHz), +50dBmV flat output level.
- f1 = 83.25MHz; V1 = 50dBmV; f2 = 109.25MHz; V2 = 50dBmV; f-TEST = f1 + f2 = 192.5MHz.
- f1 = 187.25MHz; V1 = 50dBmV; f2 = 149.25MHz; V2 = V1 - 6dB; f3 = 196.25MHz; V3 = V1 - 6dB; f-TEST = f1 + f2 - f3 = 185.25MHz according to DIN45004B.

- 
6. Composite Triple Beat (CTB) - The CTB parameter is defined by ANSI/SCTE 6.  
Composite Second Order (CSO) - The CSO parameter (both sum and difference products) is defined by ANSI/SCTE 6.  
Cross Modulation (XMOD) - Cross modulation (XMOD) is defined by ANSI/SCTE 58, measured at baseband (selective voltmeter method), referenced to 100% modulation of the carrier being tested.
-

Package Drawing (Dimensions in millimeters)

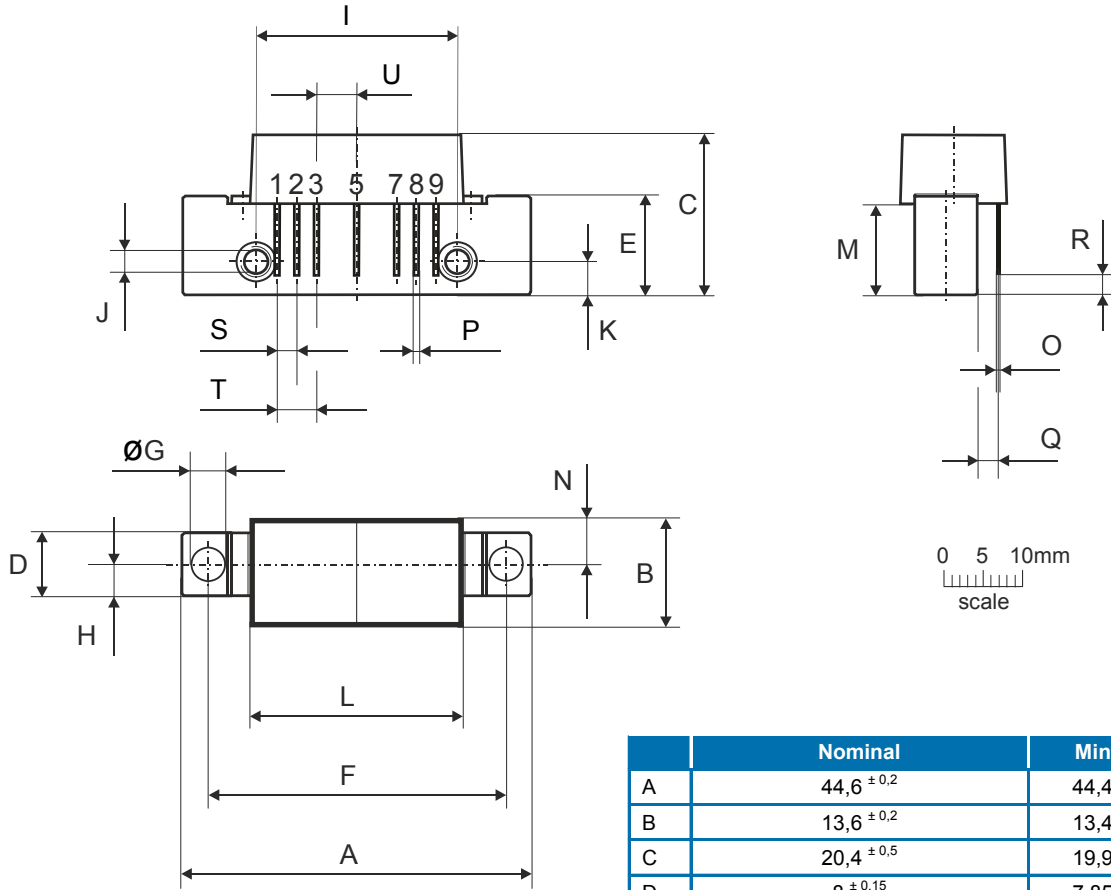

Notes:

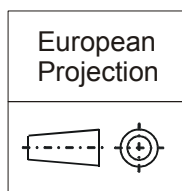

Pinning:

Pin	Name
1	Input
2-3	GND
4	
5	V+
6	
7-8	GND
9	Output

	Nominal	Min	Max
A	44,6 ± 0,2	44,4	44,8
B	13,6 ± 0,2	13,4	13,8
C	20,4 ± 0,5	19,9	20,9
D	8 ± 0,15	7,85	8,15
E	12,6 ± 0,15	12,45	12,75
F	38,1 ± 0,2	37,9	38,3
G	4 <sup>+0,2/-0,05</sup>	3,95	4,2
H	4 ± 0,2	3,8	4,2
I	25,4 ± 0,2	25,2	25,6
J	UNC 6-32	-	-
K	4,2 ± 0,2	4,0	4,4
L	27,2 ± 0,2	27,0	27,4
M	11,6 ± 0,5	11,1	12,1
N	5,8 ± 0,4	5,4	6,2
O	0,25 ± 0,02	0,23	0,27
P	0,45 ± 0,03	0,42	0,48
Q	2,54 ± 0,3	2,24	2,84
R	2,54 ± 0,5	2,04	3,04
S	2,54 ± 0,25	2,29	2,79
T	5,08 ± 0,25	4,83	5,33
U	5,08 ± 0,25	4,83	5,33

## Handling Precautions

Parameter	Rating	Standard
ESD – Human Body Model (HBM)	1C	ANSI/ESD/JEDEC JS-001-2012



Caution!  
ESD-Sensitive Device

## RoHS Compliance

This part is compliant with 2011/65/EU RoHS directive (Restrictions on the Use of Certain Hazardous Substances in Electrical and Electronic Equipment) as amended by Directive 2015/863/EU.

## Contact Information

For the latest specifications, additional product information, worldwide sales and distribution locations:

Web: [www.qorvo.com](http://www.qorvo.com)

Tel: 1-844-890-8163

Email: [customer.support@qorvo.com](mailto:customer.support@qorvo.com)

## Important Notice

The information contained herein is believed to be reliable; however, Qorvo makes no warranties regarding the information contained herein and assumes no responsibility or liability whatsoever for the use of the information contained herein. All information contained herein is subject to change without notice. Customers should obtain and verify the latest relevant information before placing orders for Qorvo products. The information contained herein or any use of such information does not grant, explicitly or implicitly, to any party any patent rights, licenses, or any other intellectual property rights, whether with regard to such information itself or anything described by such information. **THIS INFORMATION DOES NOT CONSTITUTE A WARRANTY WITH RESPECT TO THE PRODUCTS DESCRIBED HEREIN, AND QORVO HEREBY DISCLAIMS ANY AND ALL WARRANTIES WITH RESPECT TO SUCH PRODUCTS WHETHER EXPRESS OR IMPLIED BY LAW, COURSE OF DEALING, COURSE OF PERFORMANCE, USAGE OF TRADE OR OTHERWISE, INCLUDING THE IMPLIED WARRANTIES OF MERCHANTABILITY AND FITNESS FOR A PARTICULAR PURPOSE.**

Without limiting the generality of the foregoing, Qorvo products are not warranted or authorized for use as critical components in medical, life-saving, or life-sustaining applications, or other applications where a failure would reasonably be expected to cause severe personal injury or death.

Copyright 2016 © Qorvo, Inc. | Qorvo is a registered trademark of Qorvo, Inc.



Компания «ЭлектроПласт» предлагает заключение долгосрочных отношений при поставках импортных электронных компонентов на взаимовыгодных условиях!

Наши преимущества:

- Оперативные поставки широкого спектра электронных компонентов отечественного и импортного производства напрямую от производителей и с крупнейших мировых складов;
- Поставка более 17-ти миллионов наименований электронных компонентов;
- Поставка сложных, дефицитных, либо снятых с производства позиций;
- Оперативные сроки поставки под заказ (от 5 рабочих дней);
- Экспресс доставка в любую точку России;
- Техническая поддержка проекта, помощь в подборе аналогов, поставка прототипов;
- Система менеджмента качества сертифицирована по Международному стандарту ISO 9001;
- Лицензия ФСБ на осуществление работ с использованием сведений, составляющих государственную тайну;
- Поставка специализированных компонентов (Xilinx, Altera, Analog Devices, Intersil, Interpoint, Microsemi, Aeroflex, Peregrine, Syfer, Eurofarad, Texas Instrument, Miteq, Cobham, E2V, MA-COM, Hittite, Mini-Circuits, General Dynamics и др.);

Помимо этого, одним из направлений компании «ЭлектроПласт» является направление «Источники питания». Мы предлагаем Вам помощь Конструкторского отдела:

- Подбор оптимального решения, техническое обоснование при выборе компонента;
- Подбор аналогов;
- Консультации по применению компонента;
- Поставка образцов и прототипов;
- Техническая поддержка проекта;
- Защита от снятия компонента с производства.



#### Как с нами связаться

**Телефон:** 8 (812) 309 58 32 (многоканальный)

**Факс:** 8 (812) 320-02-42

**Электронная почта:** [org@eplast1.ru](mailto:org@eplast1.ru)

**Адрес:** 198099, г. Санкт-Петербург, ул. Калинина, дом 2, корпус 4, литера А.