

FEATURES

- *Guaranteed* Maximum 0.5mV Input Offset Voltage
- Input Protection Diodes
- Operates From Single 5V Supply
- 25mA Drive Capability
- 80ns Response Time

APPLICATIONS

- Window Detectors
- High Speed One Shot
- Relay/Lamp Drivers
- Voltage Controlled Oscillators

DESCRIPTION

The LT[®]119A is an improved version of the LM119 dual comparator. It features lower input offset voltage and offset current, higher voltage gain, guaranteed common mode rejection and input protection diodes.

The LT119A is capable of operation over a supply range from 5V to ± 15 V and can drive 25mA loads from each open collector output. A separate ground pin allows the LT119A to isolate system grounds.

Linear Technology Corporation's advanced processing, design techniques and reliability make the LT119A/LT319A an ideal choice over previous devices in most comparator applications.

LT, LT, LTC, LTM, Linear Technology and the Linear logo are registered trademarks of Linear Technology Corporation. All other trademarks are the property of their respective owners.

TYPICAL APPLICATION

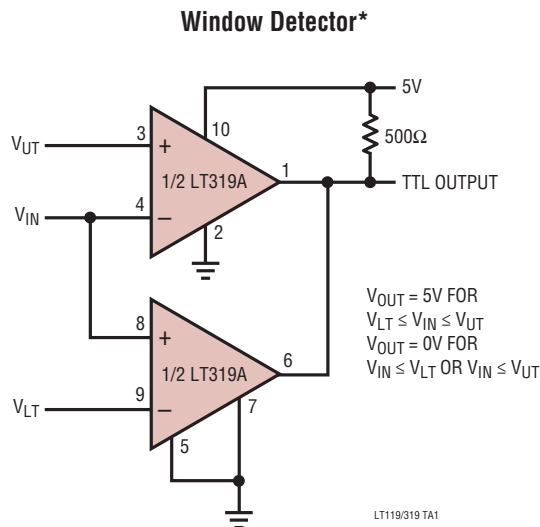

*ALLOWED WINDOW FOR SINGLE 5V SUPPLY IS 1.2V TO 3.8V

Response Time For Various Input Overdrives

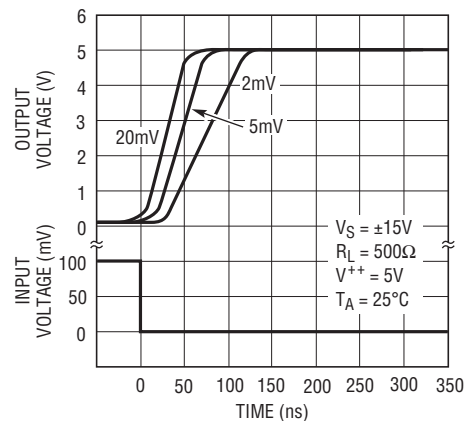

LT119/G19 TA2

LT119A/LT319A LM119/LM319

ABSOLUTE MAXIMUM RATINGS (Note 1)

Supply Voltage	36V	Output Short-Circuit Duration	10s
Output to Negative Supply Voltage	36V	Operating Temperature Range	
Ground to Negative Supply Voltage	25V	LT119A, LM119 OBSOLETE	-55°C to 125°C
Ground to Positive Supply Voltage.....	18V	LT319A, LM319.....	0°C to 70°C
Differential Input Voltage (Note 6)	±5V	Storage Temperature Range	-65°C to 150°C
Differential Input Current (Note 6)	±5mA	Lead Temperature (Soldering, 10 sec).....	300°C
Input Voltage (Note 2)			

PIN CONFIGURATION

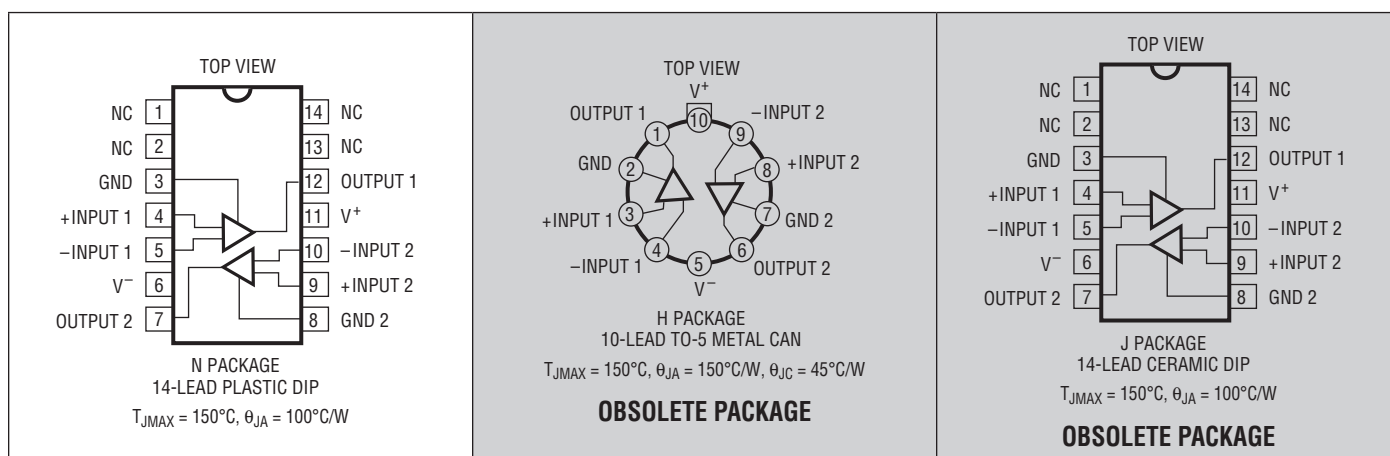

ORDER INFORMATION

LEAD FREE FINISH	PART MARKING	PACKAGE DESCRIPTION	SPECIFIED TEMPERATURE RANGE
LT319AN#PBF	LT319AN	14-Lead Plastic DIP	0°C to 70°C
LM319N#PBF	LM319N	14-Lead Plastic DIP	0°C to 70°C
OBSOLETE PACKAGES			
LT119AH#PBF	LT119AH	10-Lead TO-5 Metal Can	-55°C to 125°C
LM119H#PBF	LM119H	10-Lead TO-5 Metal Can	-55°C to 125°C
LT319AH#PBF	LT319AH	10-Lead TO-5 Metal Can	0°C to 70°C
LM319H#PBF	LM319H	10-Lead TO-5 Metal Can	0°C to 70°C
LT119AJ#PBF	LT119AJ	14-Lead Ceramic DIP	-55°C to 125°C
LM119J#PBF	LM119J	14-Lead Ceramic DIP	-55°C to 125°C
LT319AJ#PBF	LT319AJ	14-Lead Ceramic DIP	0°C to 70°C
LM319J#PBF	LM319J	14-Lead Ceramic DIP	0°C to 70°C

Consult LTC Marketing for parts specified with wider operating temperature ranges.
Consult LTC Marketing for information on nonstandard lead based finish parts.

For more information on lead free part markings, go to: <http://www.linear.com/leadfree/>

For more information on tape and reel specifications, go to: <http://www.linear.com/tapeandreeel/>

ELECTRICAL CHARACTERISTICS The ● denotes the specifications which apply over the full operating temperature range, otherwise specifications are at $T_A = 25^\circ\text{C}$. (Note 3)

SYMBOL	PARAMETER	CONDITIONS	LT119A			LM119			SYMBOL	
			MIN	TYP	MAX	MIN	TYP	MAX		
V_{OS}	Input Offset Voltage	$V_S = \pm 15\text{V}$, $V_{CM} = 0$		0.3	0.5			4	mV	
		(Note 4)	●	0.5 1.2	1.0 2.0		0.7 7	4	mV mV	
CMRR	Common Mode Rejection Ratio		90	106					dB	
I_{OS}	Input Offset Current	(Note 4)	●	20 75	40		30 100	75	nA nA	
I_B	Input Bias Current	(Note 4)	●	150	500 1000		150 1000	500	nA nA	
A_V	Voltage Gain		20	40		10	40		V/mV	
	Response Time	(Note 5)		80			80		ns	
V_{SAT}	Saturation Voltage	$V_{IN} \leq -5\text{mV}$, $I_O = 25\text{mA}$, $V^+ \geq 4.5\text{V}$, $V^- = 0\text{V}$		0.75	1.5		0.75	1.5	V	
		$V_{IN} \leq -6\text{mV}$, $I_{SINK} \leq 3.2\text{mA}$ $T_A \geq 0^\circ\text{C}$ $T_A \leq 0^\circ\text{C}$		0.23	0.4 0.6		0.23	0.4 0.6	V V	
	Output Leakage Current	$V_{IN} \geq 5\text{mV}$, V_{OUT} to $V^- = 35\text{V}$	●	0.2 1	2 10		0.2 1	2 10	μA μA	
	Input Voltage Range	$V_S = \pm 15\text{V}$	●	-12	± 13	12	-12	± 13	12	V
		$V^+ = 5\text{V}$, $V^- = 0\text{V}$	●	1		3	1		3	V
	Differential Input Voltage		●		± 5			± 5	V	
I_S	Supply Current	$V^+ = 5\text{V}$, $V^- = 0\text{V}$		4.3			4.3		mA	
	Positive Supply Current	$V_S = \pm 15\text{V}$		8	11.5		8	11.5	mA	
	Negative Supply Current	$V_S = \pm 15\text{V}$		3	4.5		3	4.5	mA	

The ● denotes the specifications which apply over the full operating temperature range, otherwise specifications are at $T_A = 25^\circ\text{C}$. (Note 3)

SYMBOL	PARAMETER	CONDITIONS	LT319A			LM319			SYMBOL
			MIN	TYP	MAX	MIN	TYP	MAX	
V_{OS}	Input Offset Voltage	$V_S = \pm 15\text{V}$, $V_{CM} = 0\text{V}$		0.3	0.5			8	mV
		$R_S \leq 5\text{k}$ (Note 4)	●	0.5 2	1		2 10	8	mV mV
CMRR	Common Mode Rejection Ratio		90	106					dB
I_{OS}	Input Offset Current	(Note 4)	●	30 60	40		80 300	200	nA nA
I_B	Input Bias Current	(Note 4)	●	150	500 1000		250 1200	1000	nA nA
A_V	Voltage Gain		20	40		8	40		V/mV
	Response Time	(Note 5)		80			80		ns
V_{SAT}	Saturation Voltage	$V_{IN} \leq -10\text{mV}$, $I_{SINK} = 25\text{mA}$		0.75	1.5		0.75	1.5	V
		$V^+ \geq 4.5\text{V}$, $V^- = 0\text{V}$, $V_{IN} \leq -10\text{mV}$, $I_{SINK} \leq 3.2\text{mA}$	●	0.3	0.4		0.3	0.4	V
	Output Leakage Current	$V_{IN} \geq 10\text{mV}$, V_{OUT} to $V^- = 35\text{V}$		0.2	10		0.2	10	μA
	Input Voltage Range	$V_S = \pm 15\text{V}$	●		± 13			± 13	V
		$V^+ = 5\text{V}$, $V^- = 0\text{V}$	●	1		3	1		3
	Differential Input Voltage		●		± 5			± 5	V
I_S	Supply Current	$V^+ = 5\text{V}$, $V^- = 0\text{V}$		4.3			4.3		mA
	Positive Supply Current	$V_S = \pm 15\text{V}$		8	12.5		8	12.5	mA
	Negative Supply Current	$V_S = \pm 15\text{V}$		3	5		3	5	mA

ELECTRICAL CHARACTERISTICS

Note 1: Stresses beyond those listed under Absolute Maximum Ratings may cause permanent damage to the device. Exposure to any Absolute Maximum Rating condition for extended periods may affect device reliability and lifetime.

Note 2: For supply voltages less than $\pm 15\text{V}$, the maximum input voltage is equal to the supply voltage.

Note 3: Unless otherwise noted, supply voltage equals $\pm 15\text{V}$ and $V_{CM} = 0\text{V}$, $T_A = 25^\circ\text{C}$. The ground pin is grounded. Note that the maximum voltage allowed between the ground pin and V^+ is 18V . Do not tie the ground pin to V^- when the power supply voltage exceeds $\pm 9\text{V}$. The offset voltage, offset current and bias current specifications apply for all supply voltages between $\pm 15\text{V}$ and 5V unless otherwise specified.

Note 4: The offset voltages and currents given are the maximum values required to drive the output within 1V of either supply with a 1mA load, thus these parameters define an error band and take into account the worst case effects of voltage gain and input impedance.

Note 5: Response time specified is for a 100mV input step with 5mV overdrive.

Note 6: Inputs are protected with back-to-back 5.6V zener diodes. This limits maximum differential input voltage to $\pm 5\text{V}$ if current is unlimited. Larger differential input drive is allowed if input current is limited to $\pm 5\text{mA}$ with external resistance.

TYPICAL PERFORMANCE CHARACTERISTICS

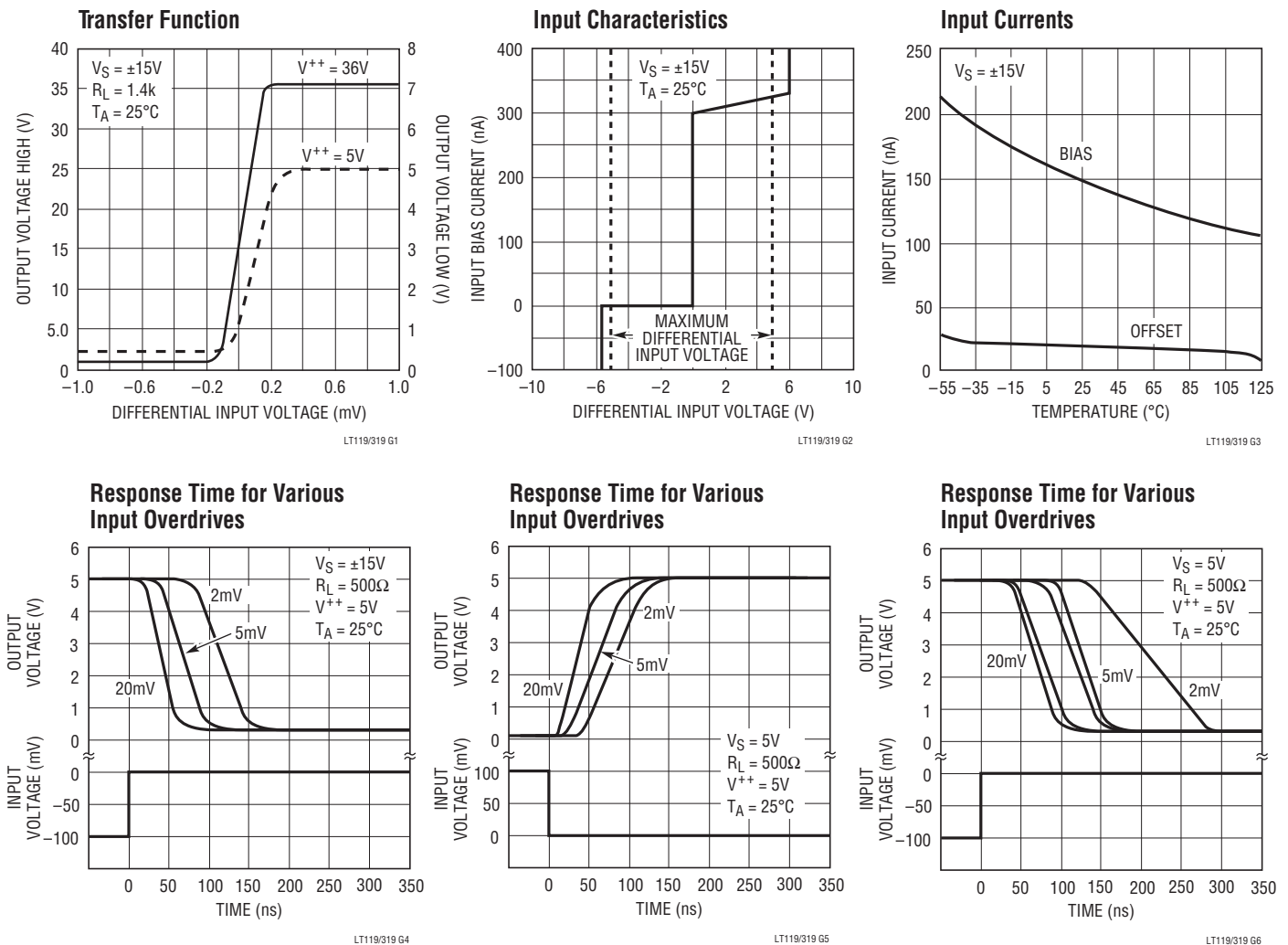

TYPICAL PERFORMANCE CHARACTERISTICS

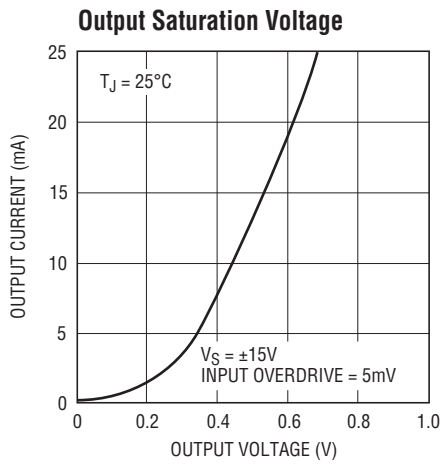

LT119/G19 G7

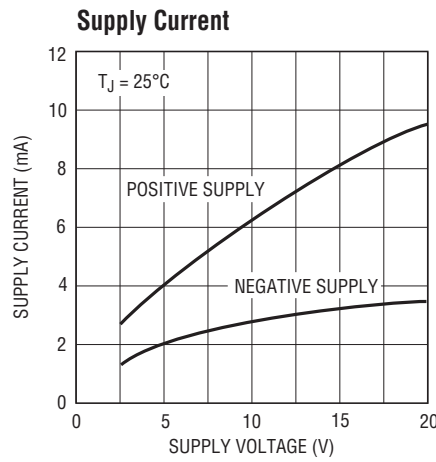

LT119/G19 G8

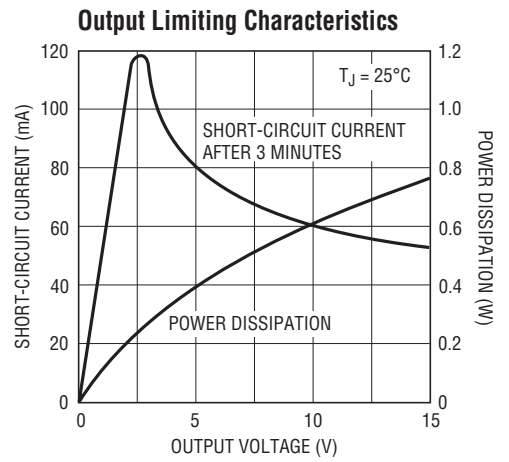

LT119/G19 G9

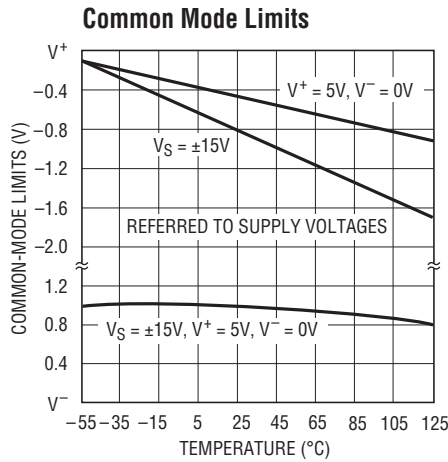

LT119/G19 G10

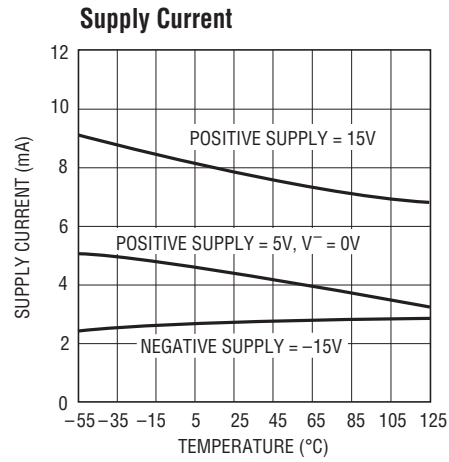

LT119/G19 G11

TYPICAL APPLICATIONS

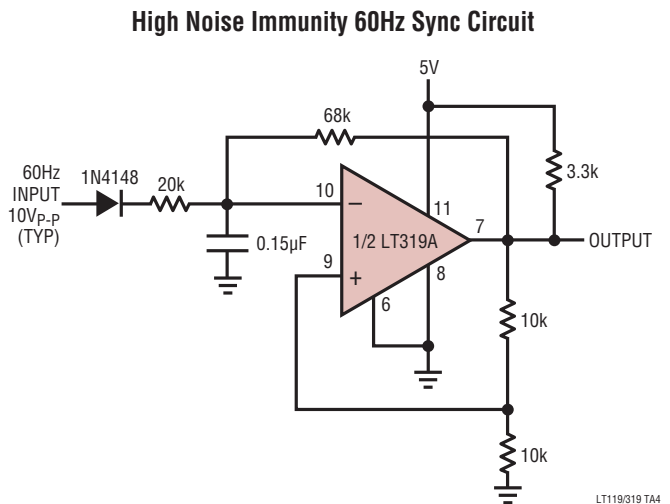
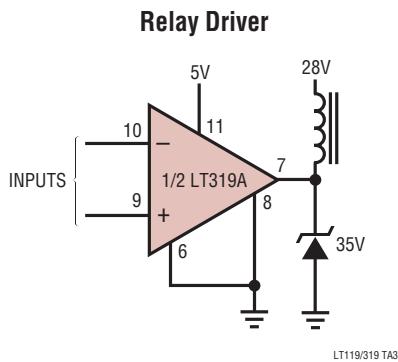

TYPICAL APPLICATIONS

**Voltage Controlled Crystal Oscillator
With 100ppm Trim Range**

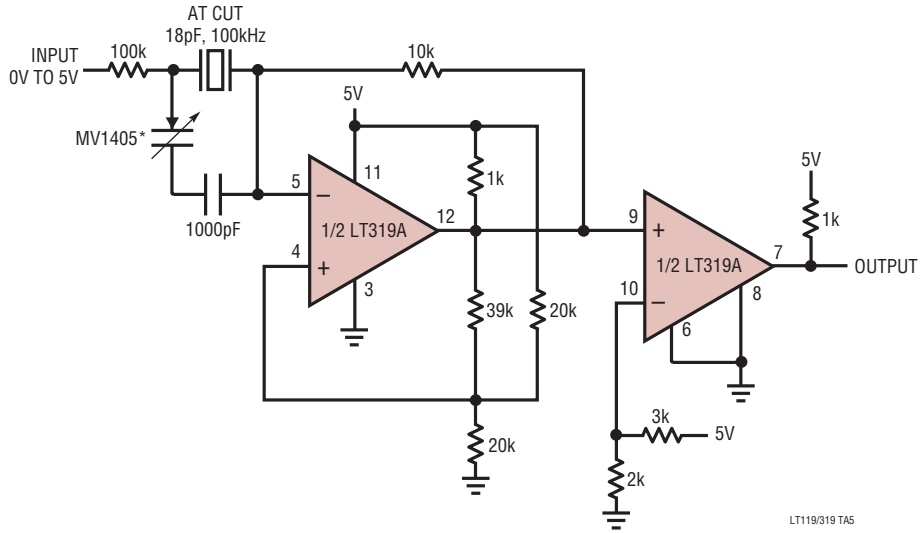

Voltage Controlled High Speed One Shot

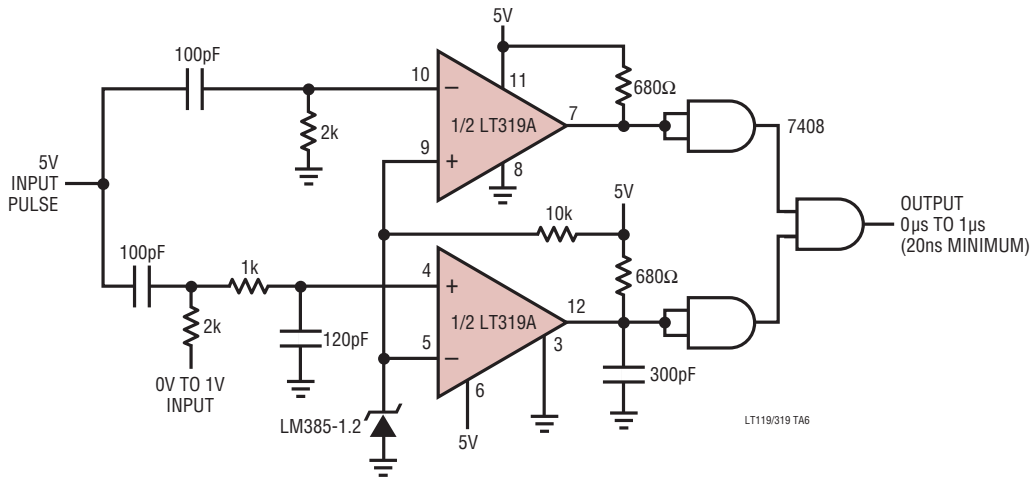

TYPICAL APPLICATIONS

10-Bit Serial Output A/D Converter

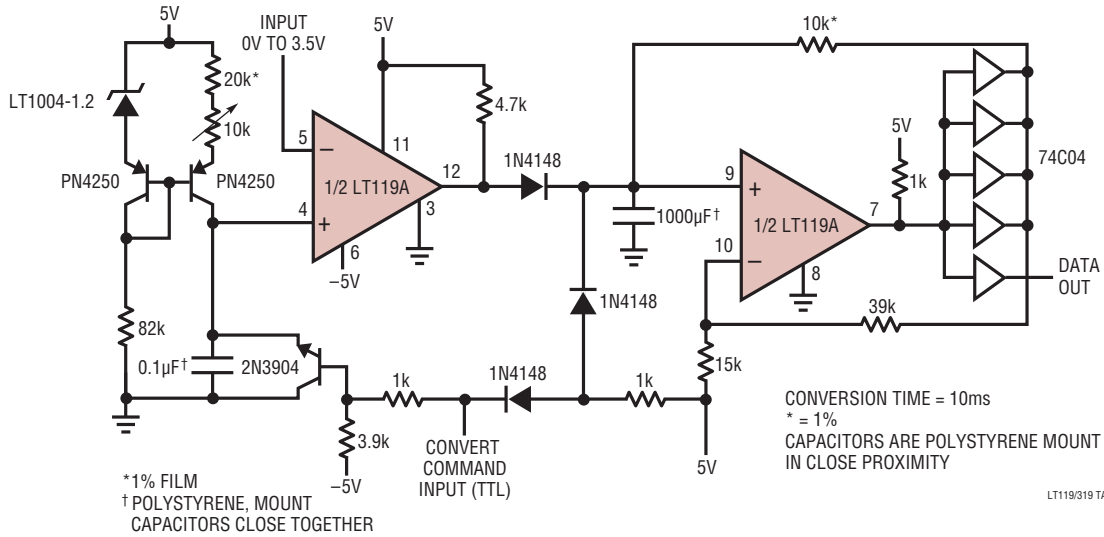

5 Microsecond Sample-and-Hold with Zero Hold Step

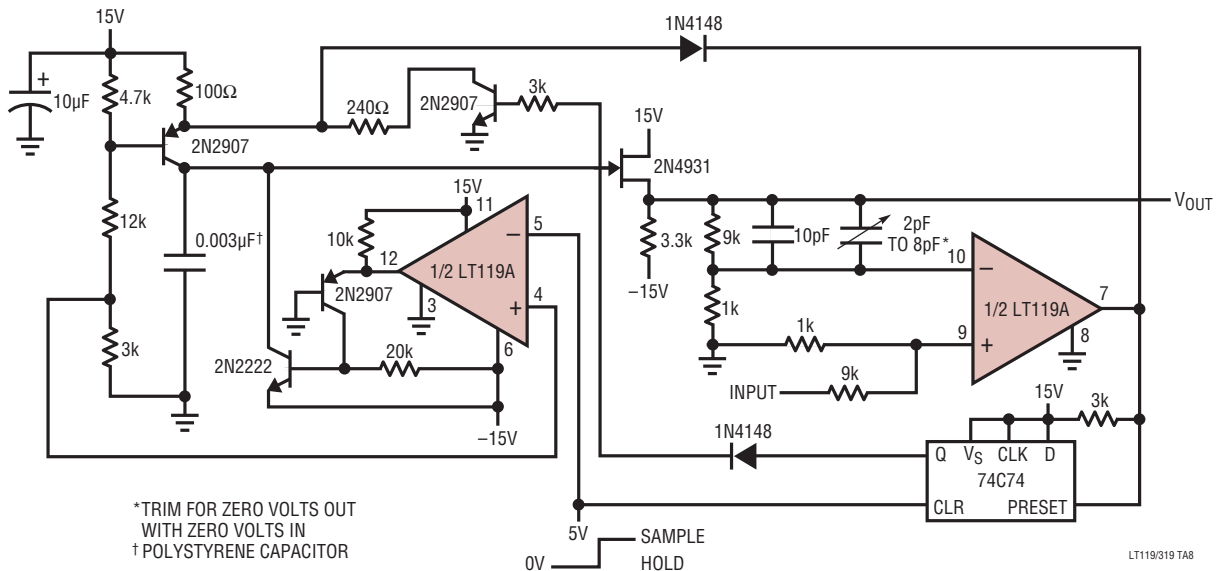

LT119A/LT319A LM119/LM319

SCHEMATIC DIAGRAM

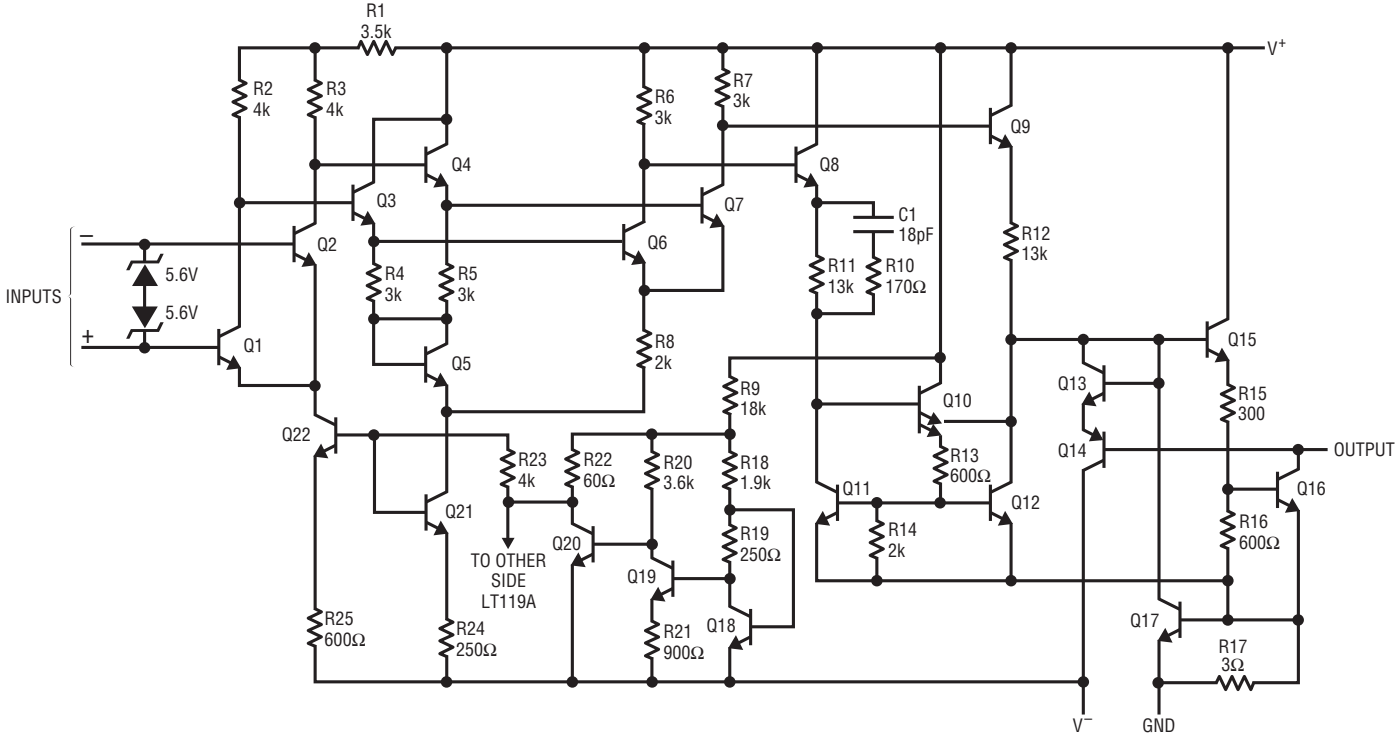

PACKAGE DESCRIPTION

Please refer to <http://www.linear.com/designtools/packaging/> for the most recent package drawings.

N Package
14-Lead PDIP (Narrow .300 Inch)
(Reference LTC DWG # 05-08-1510 Rev I)

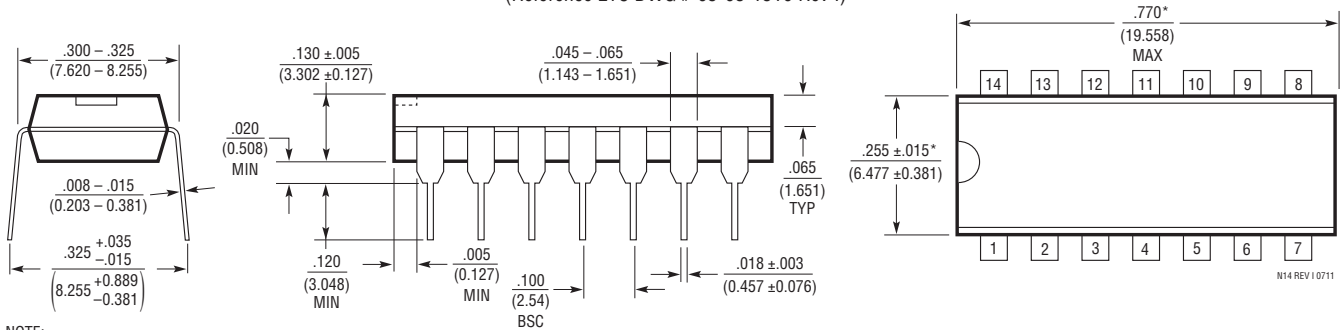

NOTE:
1. DIMENSIONS ARE $\frac{\text{INCHES}}{\text{MILLIMETERS}}$
*THESE DIMENSIONS DO NOT INCLUDE MOLD FLASH OR PROTRUSIONS.
MOLD FLASH OR PROTRUSIONS SHALL NOT EXCEED .010 INCH (0.254mm)

J Package
14-Lead CERDIP (Narrow .300 Inch, Hermetic)
(Reference LTC DWG # 05-08-1110)

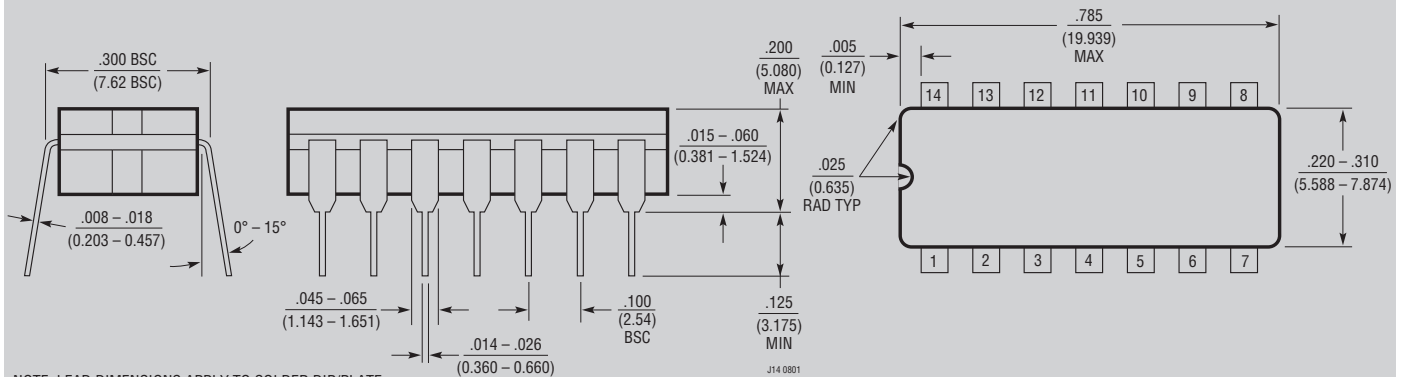

NOTE: LEAD DIMENSIONS APPLY TO SOLDER DIP/PLATE OR TIN PLATE LEADS

OBSOLETE PACKAGE

PACKAGE DESCRIPTION

Please refer to <http://www.linear.com/designtools/packaging/> for the most recent package drawings.

H Package
10-Lead TO-5 Metal Can
(Reference LTC DWG # 05-08-1322)

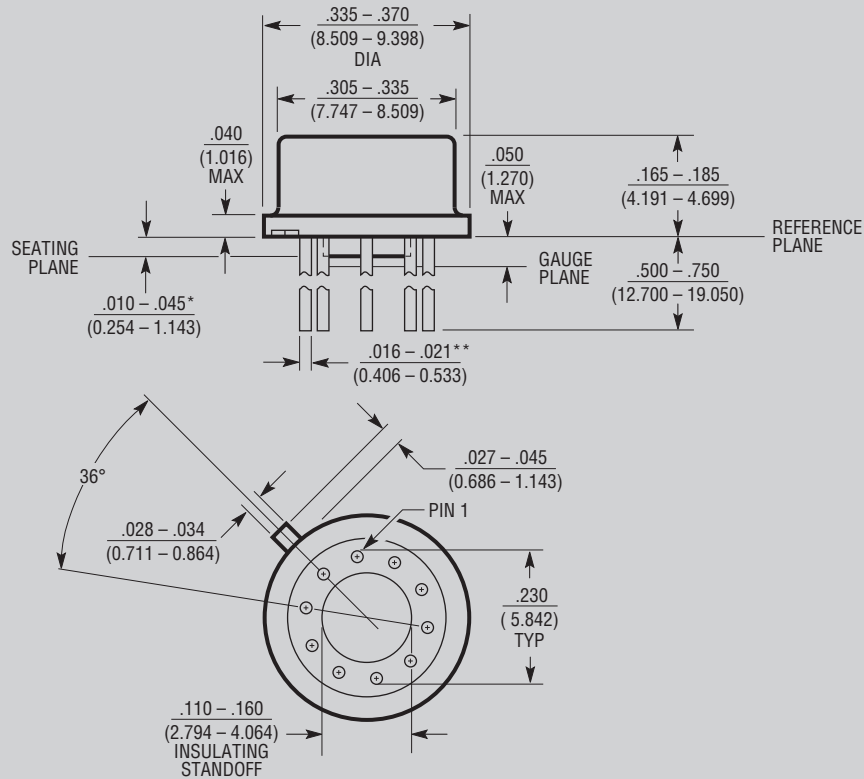

* LEAD DIAMETER IS UNCONTROLLED BETWEEN THE REFERENCE PLANE AND THE SEATING PLANE

** FOR SOLDER DIP LEAD FINISH, LEAD DIAMETER IS $.016 - .024$ (0.406 - 0.610) H10(TO-5) 0204

OBSOLETE PACKAGE

REVISION HISTORY (Revision history begins at Rev C)

REV	DATE	DESCRIPTION	PAGE NUMBER
C	3/12	V_{SAT} Conditions corrected from $V_{IN} \leq 6mA$ to $V_{IN} \leq 6mV$	3

LT119A/LT319A LM119/LM319

TYPICAL APPLICATION

5kHz to 2MHz V → F Converter

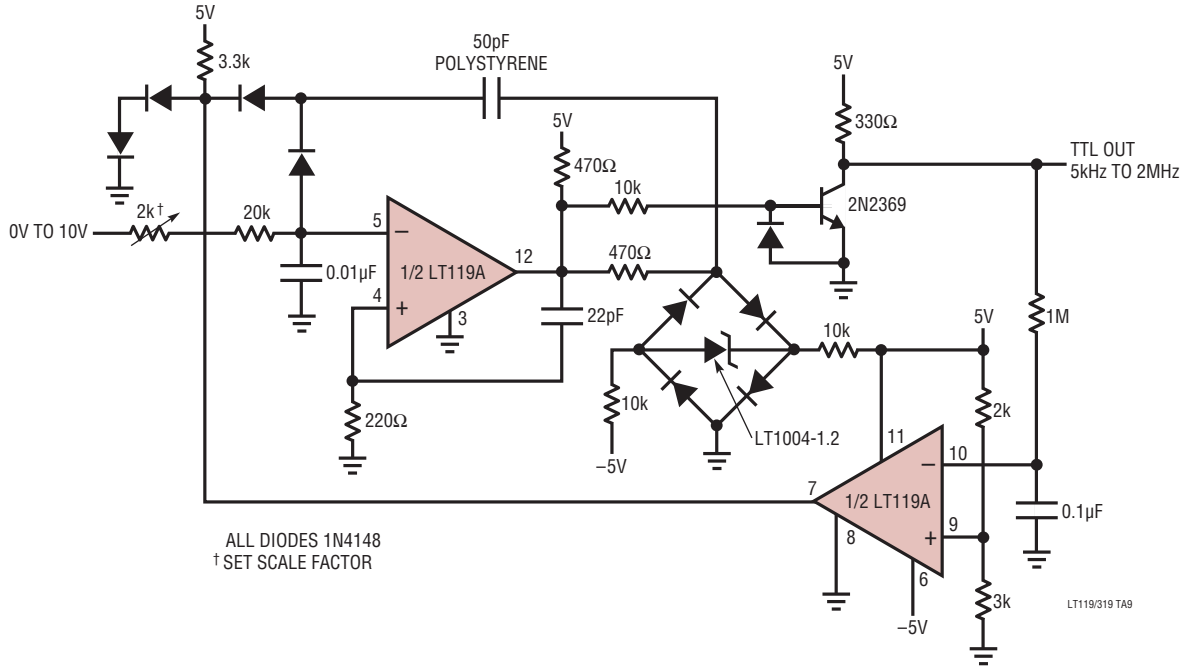



Компания «ЭлектроПласт» предлагает заключение долгосрочных отношений при поставках импортных электронных компонентов на взаимовыгодных условиях!

Наши преимущества:

- Оперативные поставки широкого спектра электронных компонентов отечественного и импортного производства напрямую от производителей и с крупнейших мировых складов;
- Поставка более 17-ти миллионов наименований электронных компонентов;
- Поставка сложных, дефицитных, либо снятых с производства позиций;
- Оперативные сроки поставки под заказ (от 5 рабочих дней);
- Экспресс доставка в любую точку России;
- Техническая поддержка проекта, помощь в подборе аналогов, поставка прототипов;
- Система менеджмента качества сертифицирована по Международному стандарту ISO 9001;
- Лицензия ФСБ на осуществление работ с использованием сведений, составляющих государственную тайну;
- Поставка специализированных компонентов (Xilinx, Altera, Analog Devices, Intersil, Interpoint, Microsemi, Aeroflex, Peregrine, Syfer, Eurofarad, Texas Instrument, Miteq, Cobham, E2V, MA-COM, Hittite, Mini-Circuits, General Dynamics и др.);

Помимо этого, одним из направлений компании «ЭлектроПласт» является направление «Источники питания». Мы предлагаем Вам помощь Конструкторского отдела:

- Подбор оптимального решения, техническое обоснование при выборе компонента;
- Подбор аналогов;
- Консультации по применению компонента;
- Поставка образцов и прототипов;
- Техническая поддержка проекта;
- Защита от снятия компонента с производства.



Как с нами связаться

Телефон: 8 (812) 309 58 32 (многоканальный)

Факс: 8 (812) 320-02-42

Электронная почта: org@eplast1.ru

Адрес: 198099, г. Санкт-Петербург, ул. Калинина, дом 2, корпус 4, литера А.