

Single Channel 16-bit CIS/CCD AFE with 4-bit Wide Output

DESCRIPTION

The WM8253 is a 16-bit analogue front end/digitiser IC which processes and digitises the analogue output signals from CCD sensors or Contact Image Sensors (CIS) at pixel sample rates of up to 6MSPS.

The device includes a complete signal processing channel containing Reset Level Clamping, Correlated Double Sampling, Programmable Gain and Offset adjust functions. Internal multiplexers allow fast switching of offset and gain for line-by-line colour processing. The output from this channel is time multiplexed into a high-speed 16-bit Analogue to Digital Converter. The digital output data is available in 4-bit wide multiplexed format.

An internal 4-bit DAC is supplied for internal reference level generation. This may be used during CDS to reference CIS signals or during Reset Level Clamping to clamp CCD signals. An external reference level may also be supplied. ADC references are generated internally, ensuring optimum performance from the device.

The device uses an analogue supply voltage of 3.3V and a digital interface supply of between 2.5V and 3.3V. The WM8253 typically only consumes 132mW when operating from a single 3.3V supply.

FEATURES

- 16-bit ADC
- 6MSPS conversion rate
- Low power - 132mW typical
- 3.3V single supply or 3.3V/2.5V dual supply operation
- Single channel operation
- Correlated double sampling
- Programmable gain (8-bit resolution)
- Programmable offset adjust (8-bit resolution)
- Programmable clamp voltage
- 4-bit wide multiplexed data output format
- Internally generated voltage references
- 20-lead SSOP package
- Serial control interface

APPLICATIONS

- Flatbed and sheetfeed scanners
- USB compatible scanners
- Multi-function peripherals
- High-performance CCD sensor interface

BLOCK DIAGRAM

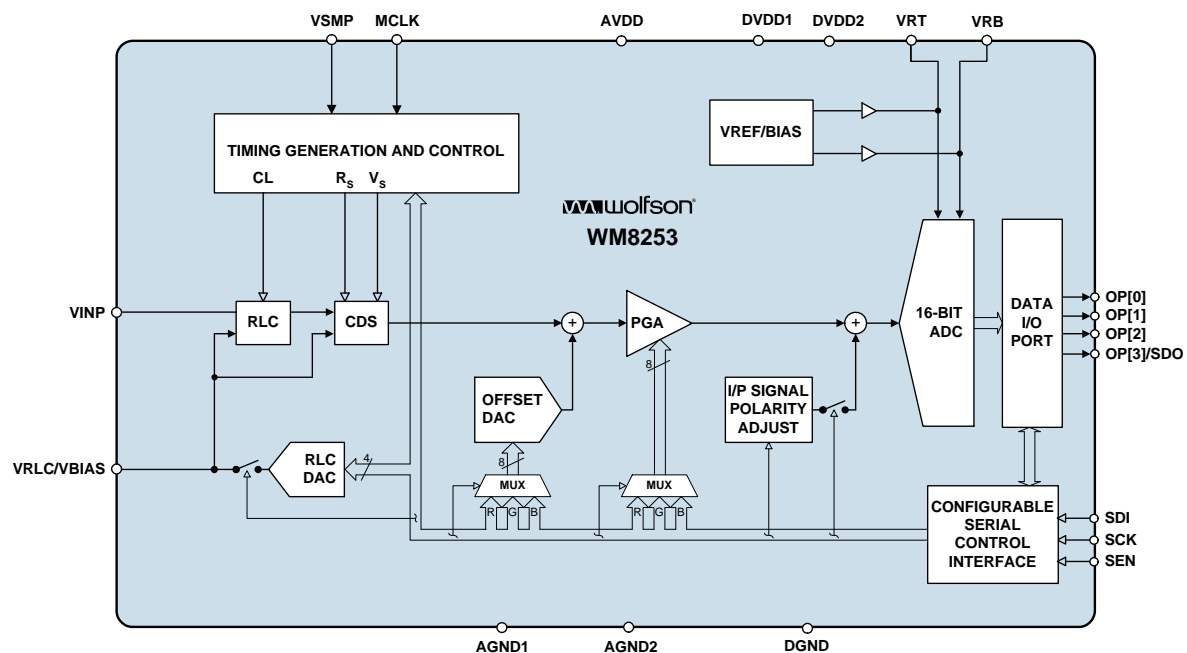
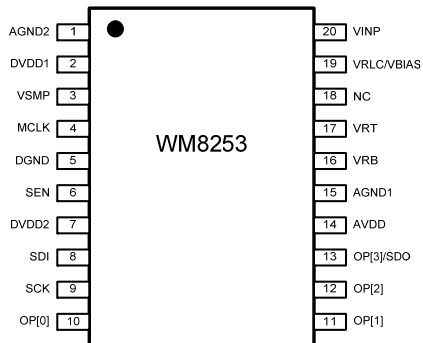

TABLE OF CONTENTS

DESCRIPTION	1
FEATURES	1
APPLICATIONS	1
BLOCK DIAGRAM	1
PIN CONFIGURATION	3
ORDERING INFORMATION	3
PIN DESCRIPTION	4
ABSOLUTE MAXIMUM RATINGS	5
RECOMMENDED OPERATING CONDITIONS	5
ELECTRICAL CHARACTERISTICS	6
INPUT VIDEO SAMPLING	8
OUTPUT DATA TIMING	8
SERIAL INTERFACE.....	9
DEVICE DESCRIPTION	10
INTRODUCTION	10
INPUT SAMPLING	10
RESET LEVEL CLAMPING (RLC)	10
CDS/NON-CDS PROCESSING.....	12
OFFSET ADJUST AND PROGRAMMABLE GAIN.....	12
ADC INPUT BLACK LEVEL ADJUST.....	13
OVERALL SIGNAL FLOW SUMMARY	13
CALCULATING OUTPUT FOR ANY GIVEN INPUT	14
OUTPUT DATA FORMAT	15
CONTROL INTERFACE.....	16
TIMING REQUIREMENTS	16
PROGRAMMABLE VSMP DETECT CIRCUIT	17
REFERENCES	18
POWER SUPPLY	18
POWER MANAGEMENT.....	18
OPERATING MODES	18
OPERATING MODE TIMING DIAGRAMS	19
DEVICE CONFIGURATION	21
REGISTER MAP	21
REGISTER MAP DESCRIPTION	22
RECOMMENDED EXTERNAL COMPONENTS	24
PACKAGE DIMENSIONS	25
IMPORTANT NOTICE	26
ADDRESS:	26
REVISION HISTORY	27

PIN CONFIGURATION



ORDERING INFORMATION

ORDER CODE	TEMPERATURE RANGE	PACKAGE	MOISTURE SENSITIVITY LEVEL	PEAK SOLDERING TEMPERATURE
WM8253SCDS/V	0 to 70°C	20-lead SSOP (Pb-free, drybagged)	MSL3	260°C
WM8253SCDS/RV	0 to 70°C	20-lead SSOP (Pb-free, drybagged, tape and reel)	MSL3	260°C

Note:

Reel quantity = 2,000

PIN DESCRIPTION

PIN NO	NAME	TYPE	DESCRIPTION																				
1	AGND2	Supply	Analogue ground pin (0V)																				
2	DVDD1	Supply	Digital Core supply (3.3V)																				
3	VSMP	Digital input	Video sample synchronisation pulse.																				
4	MCLK	Digital input	Master clock. This clock is applied at N times the input pixel rate (N = 2, 3, 6, 8 or any multiple of 2 thereafter depending on input sample mode).																				
5	DGND	Supply	Digital ground (0V).																				
6	SEN	Digital input	Enables the serial interface when high.																				
7	DVDD2	Supply	Digital I/O supply (2.5V-3.3V), all digital I/O pins.																				
8	SDI	Digital input	Serial data input.																				
9	SCK	Digital input	Serial clock.																				
			Digital multiplexed output data bus. ADC output data (d15:d0) is available in 4-bit multiplexed format as shown below.																				
			<table border="1"> <thead> <tr> <th>A</th> <th>B</th> <th>C</th> <th>D</th> </tr> </thead> <tbody> <tr> <td>d12</td> <td>d8</td> <td>d4</td> <td>d0</td> </tr> <tr> <td>d13</td> <td>d9</td> <td>d5</td> <td>d1</td> </tr> <tr> <td>d14</td> <td>d10</td> <td>d6</td> <td>d2</td> </tr> <tr> <td>d15</td> <td>d11</td> <td>d7</td> <td>d3</td> </tr> </tbody> </table>	A	B	C	D	d12	d8	d4	d0	d13	d9	d5	d1	d14	d10	d6	d2	d15	d11	d7	d3
A	B	C	D																				
d12	d8	d4	d0																				
d13	d9	d5	d1																				
d14	d10	d6	d2																				
d15	d11	d7	d3																				
10	OP[0]	Digital output																					
11	OP[1]	Digital output																					
12	OP[2]	Digital output																					
13	OP[3]/SDO	Digital output																					
			Alternatively, pin OP[3]/SDO may be used to output register read-back data when address bit 4=1 and SEN has been pulsed high. See Serial Interface description in Device Description section for further details.																				
14	AVDD	Supply	Analogue supply (3.3V)																				
15	AGND1	Supply	Analogue ground (0V).																				
16	VRB	Analogue output	Lower reference voltage. This pin must be connected to AGND via a decoupling capacitor.																				
17	VRT	Analogue output	Upper reference voltage. This pin must be connected to AGND via a decoupling capacitor.																				
18	NC	Not Connected																					
19	VRLC/VBIAS	Analogue I/O	Selectable analogue output voltage for RLC or single-ended bias reference. This pin would typically be connected to AGND via a decoupling capacitor. VRLC can be externally driven if programmed Hi-Z.																				
20	VINP	Analogue input	Video input pin.																				

ABSOLUTE MAXIMUM RATINGS

Absolute Maximum Ratings are stress ratings only. Permanent damage to the device may be caused by continuously operating at or beyond these limits. Device functional operating limits and guaranteed performance specifications are given under Electrical Characteristics at the test conditions specified.



ESD Sensitive Device. This device is manufactured on a CMOS process. It is therefore generically susceptible to damage from excessive static voltages. Proper ESD precautions must be taken during handling and storage of this device.

Wolfson tests its package types according to IPC/JEDEC J-STD-020B for Moisture Sensitivity to determine acceptable storage conditions prior to surface mount assembly. These levels are:

MSL1 = unlimited floor life at <math><30^{\circ}\text{C}</math> / 85% Relative Humidity. Not normally stored in moisture barrier bag.

MSL2 = out of bag storage for 1 year at <math><30^{\circ}\text{C}</math> / 60% Relative Humidity. Supplied in moisture barrier bag.

MSL3 = out of bag storage for 168 hours at <math><30^{\circ}\text{C}</math> / 60% Relative Humidity. Supplied in moisture barrier bag.

The Moisture Sensitivity Level for each package type is specified in Ordering Information.

CONDITION	MIN	MAX
Analogue supply voltage: AVDD	GND - 0.3V	GND + 4.2V
Digital core supply voltage: DVDD1	GND - 0.3V	GND + 4.2V
Digital IO supply voltage: DVDD2	GND - 0.3V	GND + 4.2V
Digital ground: DGND	GND - 0.3V	GND + 0.3V
Analogue grounds AGND	GND - 0.3V	GND + 0.3V
Digital inputs, digital outputs and digital I/O pins	GND - 0.3V	DVDD + 0.3V
Analogue input	GND - 0.3V	AVDD + 0.3V
Other pins	GND - 0.3V	AVDD + 0.3V
Operating temperature range: T_A	0°C	$+70^{\circ}\text{C}$

Notes:

1. GND denotes the voltage of any ground pin.
2. AGND and DGND pins are intended to be operated at the same potential. Differential voltages between these pins will degrade performance.
3. AVDD and DVDD1 pins are intended to be operated at the same potential. Differential voltages between these pins will degrade performance.

RECOMMENDED OPERATING CONDITIONS

CONDITION	SYMBOL	MIN	TYP	MAX	UNITS
Operating temperature range	T_A	0		70	$^{\circ}\text{C}$
Analogue supply voltage	AVDD	2.97	3.3	3.63	V
Digital Core supply voltage	DVDD1	2.97	3.3	3.63	V
Digital I/O supply voltage	DVDD2	2.5	3.3	3.63	V

ELECTRICAL CHARACTERISTICS

Test Conditions

AVDD = DVDD1 = DVDD2 = 3.3V, AGND = DGND = 0V, T_A = 25°C, MCLK = 36MHz, mode 1 unless otherwise stated.

PARAMETER	SYMBOL	TEST CONDITIONS	MIN	TYP	MAX	UNIT
Overall System Specification (including 16-bit ADC, PGA, Offset and CDS functions)						
Full-scale input voltage range (see Note 1)		Max Gain Min Gain		0.25 2.56		Vp-p Vp-p
Input signal limits (see Note 2)	V _{IN}		0		AVDD	V
Full-scale transition error		Gain = 0dB; PGA[7:0] = 07(hex)	-60	10	+60	mV
Zero-scale transition error		Gain = 0dB; PGA[7:0] = 07(hex)	-50	10	+50	mV
Differential non-linearity	DNL			2.4		LSB
Integral non-linearity	INL			17		LSB
Input referred noise				12		LSB rms
References						
Upper reference voltage	VRT			2.05		V
Lower reference voltage	VRB			1.05		V
Diff. reference voltage (VRT-VRB)	V _{RTB}		0.95	1.0	1.05	V
Output resistance VRT, VRB, VRX				1		Ω
VRLC/Reset-Level Clamp (RLC)						
RLC switching impedance			20	50	100	Ω
VRLC short-circuit current			1.6	2	4.5	mA
VRLC output resistance				2		Ω
VRLC Hi-Z leakage current		VRLC = 0 to AVDD			1	μA
RLCDAC resolution				4		bits
RLCDAC step size	V _{RLCSTEP}	RLCDACRNG = 0		0.18		V/step
		RLCDACRNG = 1		0.123		V/step
RLCDAC output voltage at code 0(hex)	V _{RLCBOT}	RLCDACRNG = 0		0.3		V
		RLCDACRNG = 1		0.2		V
RLCDAC output voltage at code F(hex)	V _{RLCTOP}	RLCDACRNG = 0		3.0		V
		RLCDACRNG = 1		2.05		V
Offset DAC, Monotonicity Guaranteed						
Resolution				8		bits
Differential non-linearity	DNL			0.2		LSB
Integral non-linearity	INL			0.6		LSB
Step size				2.03		mV/step
Output voltage		Code 00(hex)		-260		mV
		Code FF(hex)		+260		mV

Notes:

1. **Full-scale input voltage** denotes the peak input signal amplitude that can be gained to match the ADC input range.
2. **Input signal limits** are the limits within which the full-scale input voltage signal must lie.

Test ConditionsAVDD = DVDD1 = DVDD2 = 3.3V, AGND = DGND = 0V, T_A = 25°C, MCLK = 36MHz unless otherwise stated.

PARAMETER	SYMBOL	TEST CONDITIONS	MIN	TYP	MAX	UNIT
Programmable Gain Amplifier						
Resolution				8		bits
Gain equation				$0.78 + \frac{\text{PGA}[7:0] \times 7.57}{255}$		V/V
Max gain	G _{MAX}		8.2	8.35	8.8	V/V
Min gain	G _{MIN}		0.75	0.78	0.87	V/V
Internal channel offset	V _{OFF}			10		mV
Analogue to Digital Converter						
Resolution				16		bits
Maximum Speed					6	MSPS
Full-scale input range (2*(VRT-VRB))	V _{FS}			2.0		V
DIGITAL SPECIFICATIONS						
Digital Inputs						
High level input voltage	V _{IH}		0.8 * DVDD2			V
Low level input voltage	V _{IL}				0.2 * DVDD2	V
High level input current	I _{IH}				1	µA
Low level input current	I _{IL}				1	µA
Input capacitance	C _I			5		pF
Digital Outputs						
High level output voltage	V _{OH}	I _{OH} = 1mA	DVDD2 - 0.5			V
Low level output voltage	V _{OL}	I _{OL} = 1mA			0.5	V
Supply Currents						
Total supply current – active				45.9		mA
Total analogue AVDD, supply current – active	I _{AVDD}			39.6		mA
Total digital core, DVDD1, supply current – active	I _{DVDD1}			3		mA
Digital I/O supply current, DVDD2 – active (see note 3)	I _{DVDD2}			3.3		mA
Supply current – full power down mode				30	200	µA

Notes:

1. Digital I/O supply current depends on the capacitive load attached to the pin. The Digital I/O supply current is measured with approximately 50pF attached to the pin.

INPUT VIDEO SAMPLING

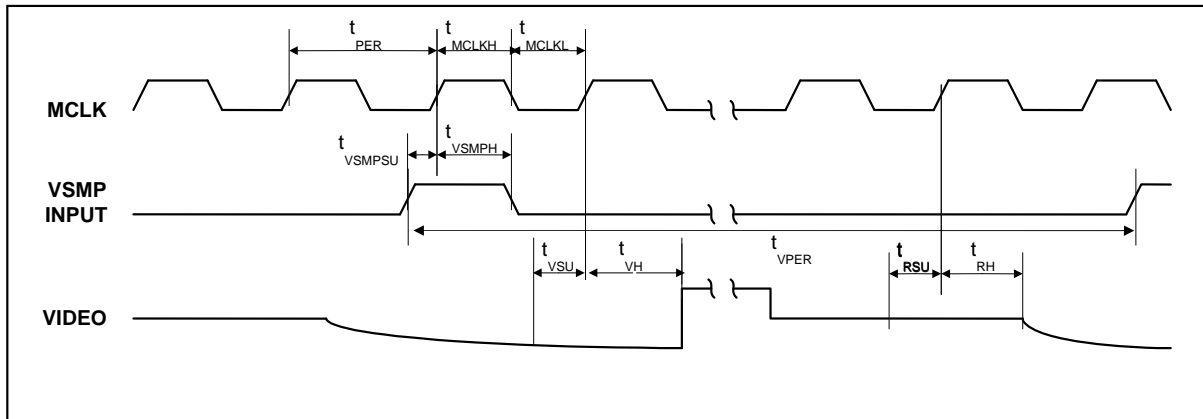

Figure 1 Input Video Timing

Note:

1. See Page 15 (Programmable VSMP Detect Circuit) for video sampling description.

Test Conditions

AVDD = DVDD1 = DVDD2 = 3.3V, AGND = DGND = 0V, $T_A = 25^\circ\text{C}$, MCLK = 36MHz unless otherwise stated.

PARAMETER	SYMBOL	TEST CONDITIONS	MIN	TYP	MAX	UNITS
MCLK period	t_{PER}		27.7			ns
MCLK high period	t_{MCLKH}		13.85			ns
MCLK low period	t_{MCLKL}		13.85			ns
VSMP period	t_{VPER}		300		1000	ns
VSMP set-up time	t_{VSMPH}		6			ns
VSMP hold time	t_{VSMPH}		3			ns
Video level set-up time	t_{VSU}		10			ns
Video level hold time	t_{VH}		3			ns
Reset level set-up time	t_{RSU}		10			ns
Reset level hold time	t_{RH}		3			ns

Notes:

1. t_{VSU} and t_{RSU} denote the set-up time required after the input video signal has settled.
2. Parameters are measured at 50% of the rising/falling edge.

OUTPUT DATA TIMING

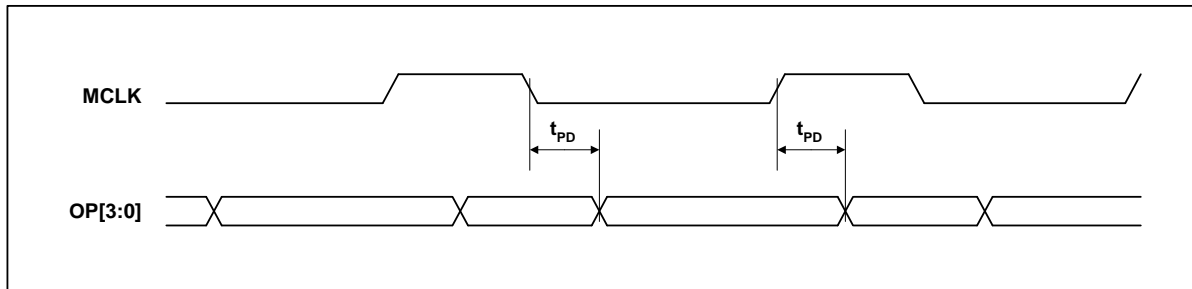

Figure 2 Output Data Timing

Test Conditions

AVDD = DVDD1 = DVDD2 = 3.3V, AGND = DGND = 0V, T_A = 25°C, MCLK = 36MHz unless otherwise stated.

PARAMETER	SYMBOL	TEST CONDITIONS	MIN	TYP	MAX	UNITS
Output propagation delay OPDLY = 00	t _{PD}	I _{OH} = 1mA, I _{OL} = 1mA	5	9	13	ns
Output propagation delay OPDLY = 01	t _{PD}	I _{OH} = 1mA, I _{OL} = 1mA	8	12	16	ns
Output propagation delay OPDLY = 10	t _{PD}	I _{OH} = 1mA, I _{OL} = 1mA	9	13	17	ns

SERIAL INTERFACE

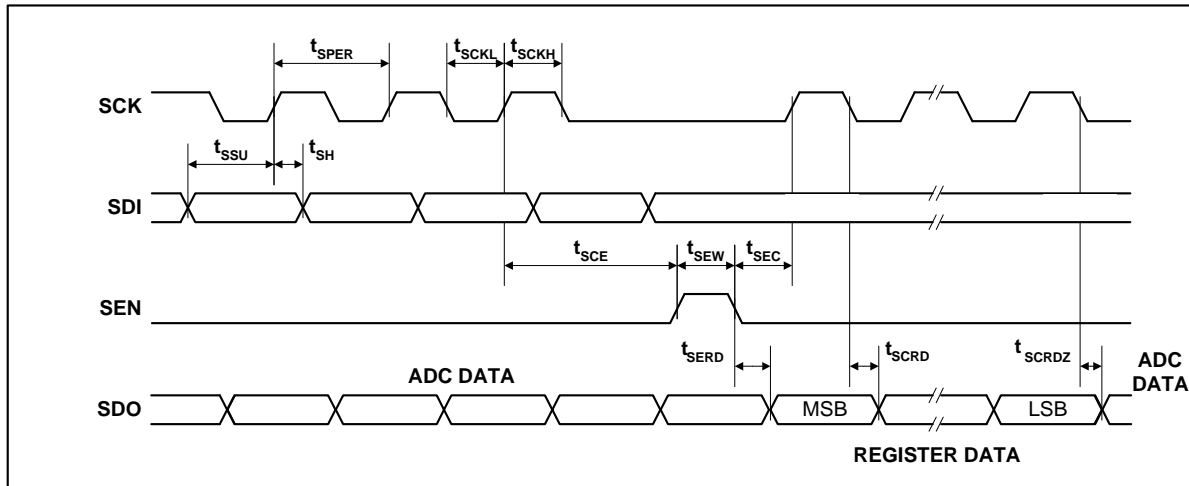

Figure 3 Serial Interface Timing

Test Conditions

AVDD = DVDD1 = DVDD2 = 3.3V, AGND = DGND = 0V, T_A = 25°C, MCLK = 36MHz unless otherwise stated.

PARAMETER	SYMBOL	TEST CONDITIONS	MIN	TYP	MAX	UNITS
SCK period	t _{SPER}		41.6			ns
SCK high	t _{SCKH}		18.8			ns
SCK low	t _{SCKL}		18.8			ns
SDI set-up time	t _{SSU}		6			ns
SDI hold time	t _{SH}		6			ns
SCK to SEN set-up time	t _{SCE}		12			ns
SEN to SCK set-up time	t _{SEC}		12			ns
SEN pulse width	t _{SEW}		25			ns
SEN low to SDO = Register data	t _{SERD}				30	ns
SCK low to SDO = Register data	t _{SCRD}				30	ns
SCK low to SDO = ADC data	t _{SCRDZ}				30	ns

Note:

- Parameters are measured at 50% of the rising/falling edge

DEVICE DESCRIPTION

INTRODUCTION

A block diagram of the device showing the signal path is presented on Page 1.

The WM8253 processes the sampled video signal on VINP with respect to the video-reset level or an internally/externally generated reference level through the analogue-processing channel.

This processing channel consists of an Input Sampling block with optional Reset Level Clamping (RLC) and Correlated Double Sampling (CDS), an 8-bit programmable offset DAC and an 8-bit Programmable Gain Amplifier (PGA).

The ADC then converts each resulting analogue signal to a 16-bit digital word. The digital output from the ADC is presented on a 4-bit wide bus.

On-chip control registers determine the configuration of the device, including the offsets and gains applied to each channel. These registers are programmable via a serial interface.

INPUT SAMPLING

The WM8253 has a single analogue processing channel and ADC, which can be used in a flexible manner to process both monochrome and line-by-line colour inputs.

Monochrome: The selected input (VINP) is sampled, processed by the analogue channel, and converted by the ADC. The same offset DAC and PGA register values are always applied.

Colour Line-by-Line: VINP is sampled and processed by the analogue channel before being converted by the ADC. The gains and offset register values applied to the PGA and offset DAC can be switched between the independent Red, Green and Blue digital registers (e.g. Red → Green → Blue → Red...) at the start of each line in order to facilitate line-by-line colour operation. The INTM[1:0] bits determine which register contents are applied (see Table 1) to the PGA and offset DAC. By using the INTM[1:0] bits to select the desired register values only one register write is required at the start of each new colour line.

RESET LEVEL CLAMPING (RLC)

To ensure that the signal applied to the WM8253 VINP pin lies within the valid input range (0V to AVDD) the CCD output signal is usually level shifted by coupling through a capacitor, C_{IN} . When active, the RLC circuit clamps the WM8253 side of this capacitor to a suitable voltage during the CCD reset period. The RLCINT register bit controls is used to activate the Reset Level Clamp circuit.

A typical input configuration is shown in Figure 4. The Timing Control Block generates a clamp pulse, CL, from MCLK and VSMP (when RLCINT is high). When CL is active the voltage on the WM8253 side of C_{IN} , at VINP, is forced to the VRLC/VBIAS voltage (V_{VRLC}) by switch 1. When the CL pulse turns off, the voltage at VINP initially remains at V_{VRLC} but any subsequent variation in sensor voltage (from reset to video level) will couple through C_{IN} to VINP.

RLC is compatible with both CDS and non-CDS operating modes, as selected by switch 2. Refer to the CDS/non-CDS Processing section.

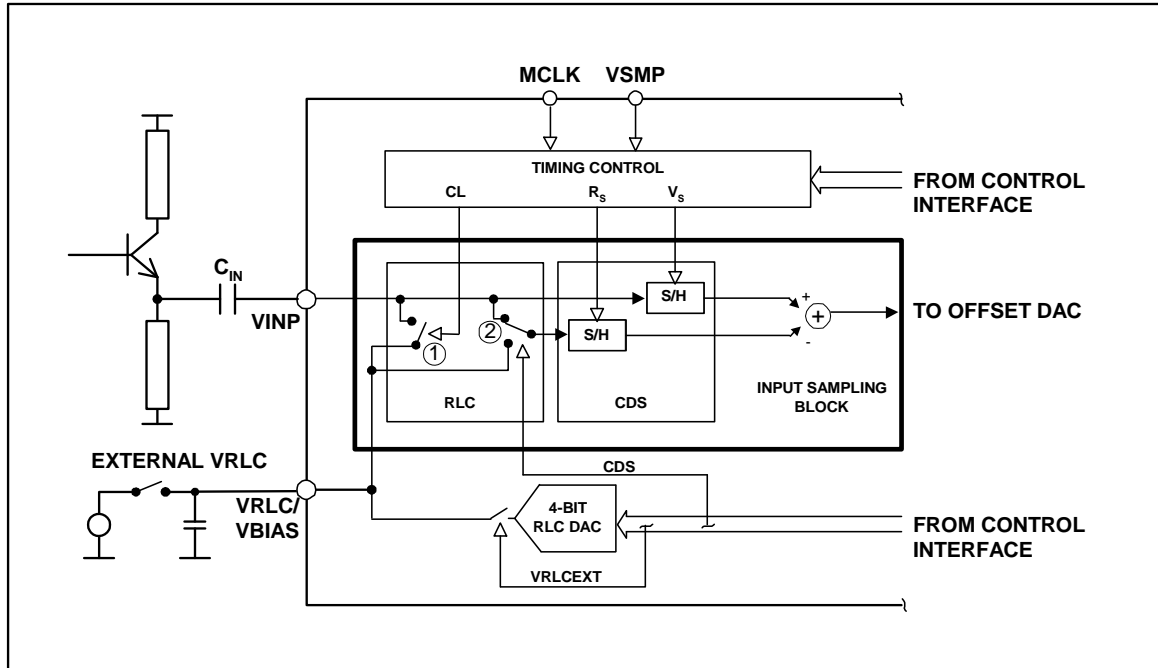

Figure 4 Reset Level Clamping and CDS Circuitry

Reset Level Clamping is controlled by register bit RLCINT. Figure 5 illustrates the effect of the RLCINT bit for a typical CCD waveform, with CL applied during the reset period.

The RLCINT register bit is sampled on the positive edge of MCLK that occurs during each VSMP pulse. The sampled level, high (or low) controls the presence (or absence) of the internal CL pulse on the next reset level. The position of CL can be adjusted by using control bits CDSREF[1:0] (Figure 6).

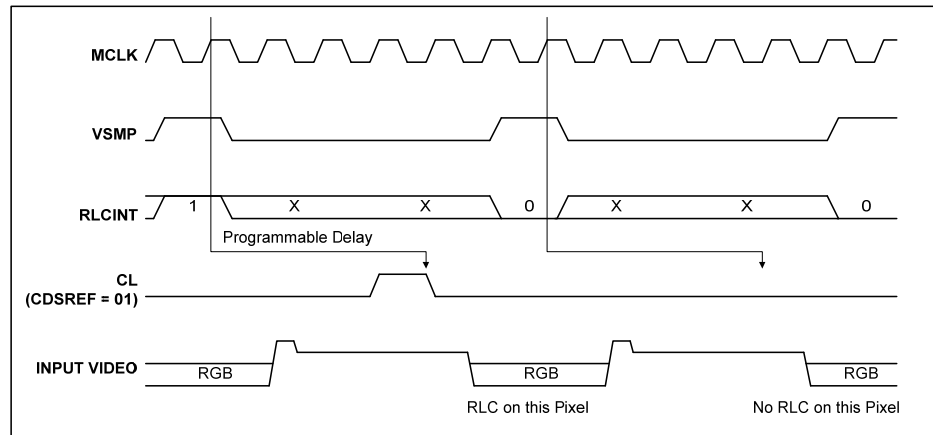

Figure 5 Relationship of RLCINT, MCLK and VSMP to Internal Clamp Pulse, CL

The VRLC/VBIAS pin can be driven internally by a 4-bit DAC (RLCDAC) by writing to control bits RLCV[3:0]. The RLCDAC range and step size may be increased by writing to control bit RLCDACRNG. Alternatively, the VRLC/VBIAS pin can be driven externally by writing to control bit VRLCEXT to disable the RLCDAC and then applying a d.c. voltage to the pin.

CDS/NON-CDS PROCESSING

For CCD type input signals, the signal may be processed using CDS, which will remove pixel-by-pixel common mode noise. For CDS operation, the video level is processed with respect to the video reset level, regardless of whether RLC has been performed. To sample using CDS, control bit CDS must be set to 1 (default), this controls switch 2 (Figure 4) and causes the signal reference to come from the video reset level. The time at which the reset level is sampled, by clock R_s/CL , is adjustable by programming control bits CDSREF[1:0], as shown in Figure 6.

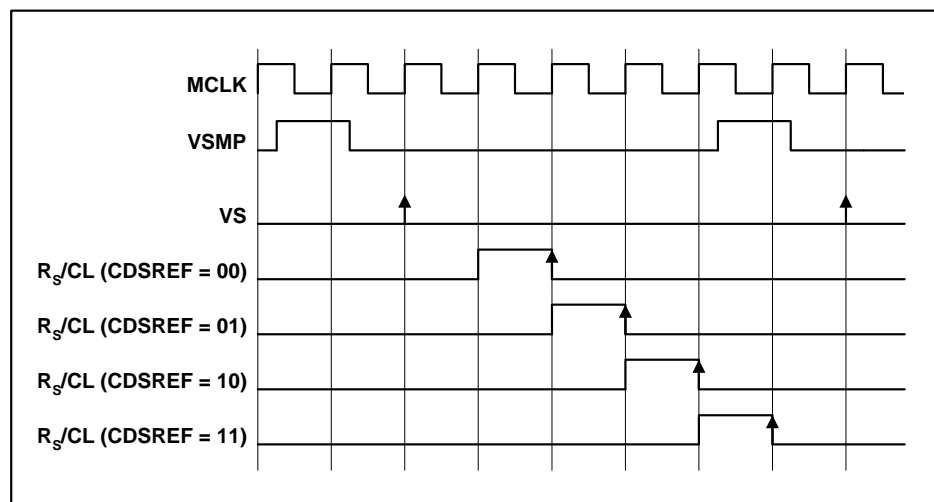

Figure 6 Reset Sample and Clamp Timing

For CIS type sensor signals, non-CDS processing is used. In this case, the video level is processed with respect to the voltage on pin VRLC/VBIAS, generated internally or externally as described above. The VRLC/VBIAS pin is sampled by R_s at the same time as V_s samples the video level in this mode.

OFFSET ADJUST AND PROGRAMMABLE GAIN

The output from the CDS block is a differential signal, which is added to the output of an 8-bit Offset DAC to compensate for offsets and then amplified by an 8-bit PGA. The gain and offset can be set for each of three colours by writing to control bits DACx[7:0] and PGAx[7:0] (where x can be R, G or B).

In colour line-by-line mode the gain and offset coefficients that are applied to the PGA and offset DAC can be multiplexed by control of the INTM[1:0] bits as shown in Table 1.

INTM[1:0]	DESCRIPTION
00	Red offset and gain registers are applied to offset DAC and PGA (DACR[7:0] and PGAR[7:0])
01	Green offset and gain registers applied to offset DAC and PGA (DACG[7:0] and PGAG[7:0])
10	Blue offset and gain registers applied to offset DAC and PGA (DACB[7:0] and PGAB[7:0])
11	Reserved.

Table 1 Offset DAC and PGA Register Control

The gain characteristic of the WM8253 PGA is shown in Figure 7. Figure 8 shows the maximum input voltage (at VINP) that can be gained up to match the ADC full-scale input range (2.0V).

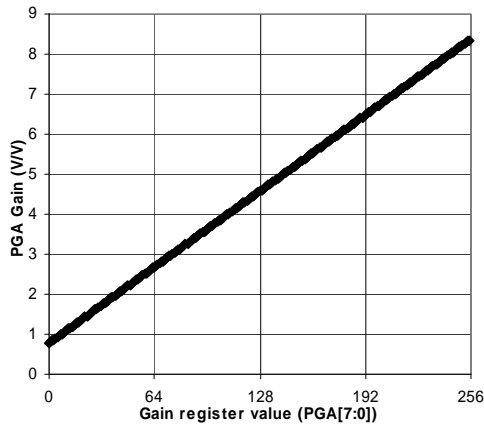

Figure 7 PGA Gain Characteristic

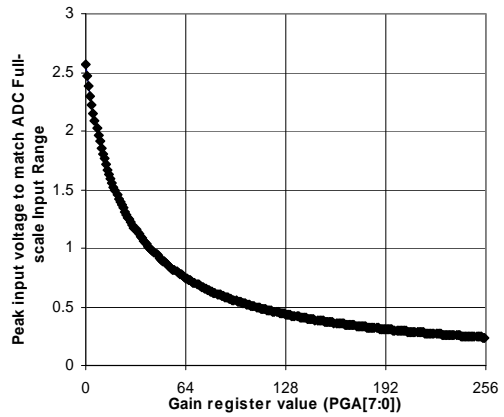

Figure 8 Peak Input Voltage to Match ADC Full-scale Range

ADC INPUT BLACK LEVEL ADJUST

The output from the PGA should be offset to match the full-scale range of the ADC ($V_{FS} = 2.0V$). For negative-going input video signals, a black level (zero differential) output from the PGA should be offset to the top of the ADC range by setting register bits $PGA_{AFS}[1:0]=10$. For positive going input signal the black level should be offset to the bottom of the ADC range by setting $PGA_{AFS}[1:0]=11$. Bipolar input video is accommodated by setting $PGA_{AFS}[1:0]=00$ or $PGA_{AFS}[1:0]=01$ (zero differential input voltage gives mid-range ADC output).

OVERALL SIGNAL FLOW SUMMARY

Figure 9 represents the processing of the video signal through the WM8253.

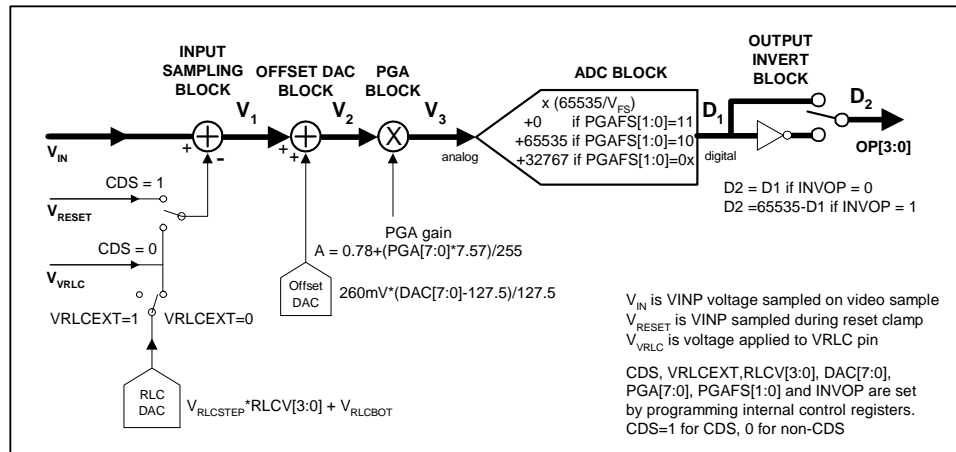

Figure 9 Overall Signal Flow

The **INPUT SAMPLING BLOCK** produces an effective input voltage V_1 . For CDS, this is the difference between the input video level V_{IN} and the input reset level V_{RESET} . For non-CDS this is the difference between the input video level V_{IN} and the voltage on the VRLC/VBIAS pin, V_{VRLC} , optionally set via the RLC DAC.

The **OFFSET DAC BLOCK** then adds the amount of fine offset adjustment required to move the black level of the input signal towards 0V, producing V_2 .

The **PGA BLOCK** then amplifies the white level of the input signal to maximise the ADC range, outputting voltage V_3 .

The **ADC BLOCK** then converts the analogue signal, V_3 , to a 16-bit unsigned digital output, D_1 .

The digital output is then inverted, if required, through the **OUTPUT INVERT BLOCK** to produce D_2 .

CALCULATING OUTPUT FOR ANY GIVEN INPUT

The following equations describe the processing of the video and reset level signals through the WM8253.

INPUT SAMPLING BLOCK: INPUT SAMPLING AND REFERENCING

If CDS = 1, (i.e. CDS operation) the previously sampled reset level, V_{RESET} , is subtracted from the input video.

$$V_1 = V_{\text{IN}} - V_{\text{RESET}} \dots\dots\dots \text{Eqn. 1}$$

If CDS = 0, (non-CDS operation) the simultaneously sampled voltage on pin VRLC is subtracted instead.

$$V_1 = V_{\text{IN}} - V_{\text{VRLC}} \dots\dots\dots \text{Eqn. 2}$$

If VRLCEXT = 1, V_{VRLC} is an externally applied voltage on pin VRLC/BIAS.

If VRLCEXT = 0, V_{VRLC} is the output from the internal RLC DAC.

$$V_{\text{VRLC}} = (V_{\text{RLCSTEP}} * \text{RLCV}[3:0]) + V_{\text{RLCBOT}} \dots\dots\dots \text{Eqn. 3}$$

V_{RLCSTEP} is the step size of the RLC DAC and V_{RLCBOT} is the minimum output of the RLC DAC.

OFFSET DAC BLOCK: OFFSET (BLACK-LEVEL) ADJUST

The resultant signal V_1 is added to the Offset DAC output.

$$V_2 = V_1 + \{260\text{mV} * (\text{DAC}[7:0] - 127.5)\} / 127.5 \dots\dots\dots \text{Eqn. 4}$$

PGA NODE: GAIN ADJUST

The signal is then multiplied by the PGA gain,

$$V_3 = V_2 * [0.78 + (\text{PGA}[7:0] * 7.57) / 255] \dots\dots\dots \text{Eqn. 5}$$

ADC BLOCK: ANALOGUE-DIGITAL CONVERSION

The analogue signal is then converted to a 16-bit unsigned number, with input range configured by PGAFS[1:0].

$$D_1[15:0] = \text{INT}\{ (V_3 / V_{\text{FS}}) * 65535\} + 32767 \quad \text{PGAFS}[1:0] = 00 \text{ or } 01 \dots\dots \text{Eqn. 6}$$

$$D_1[15:0] = \text{INT}\{ (V_3 / V_{\text{FS}}) * 65535\} \quad \text{PGAFS}[1:0] = 11 \dots\dots\dots \text{Eqn. 7}$$

$$D_1[15:0] = \text{INT}\{ (V_3 / V_{\text{FS}}) * 65535\} + 65535 \quad \text{PGAFS}[1:0] = 10 \dots\dots\dots \text{Eqn. 8}$$

where the ADC full-scale range, $V_{\text{FS}} = 2.0\text{V}$

$$\text{if } D_1[15:0] < 0 \quad D_1[15:0] = 0$$

$$\text{if } D_1[15:0] > 65535 \quad D_1[15:0] = 65535$$

OUTPUT INVERT BLOCK: POLARITY ADJUST

The polarity of the digital output may be inverted by control bit INVOP.

$$D_2[15:0] = D_1[15:0] \quad (\text{INVOP} = 0) \dots\dots\dots \text{Eqn. 9}$$

$$D_2[15:0] = 65535 - D_1[15:0] \quad (\text{INVOP} = 1) \dots\dots\dots \text{Eqn. 10}$$

OUTPUT DATA FORMAT

The digital data output from the ADC is available to the user in 4-bit wide multiplexed. Latency of valid output data with respect to VSMP is programmable by writing to control bits DEL[1:0]. The latency for each mode is shown in the Operating Mode Timing Diagrams section.

Figure 10 shows the output data formats for all modes. Table 2 summarises the output data obtained for each format.

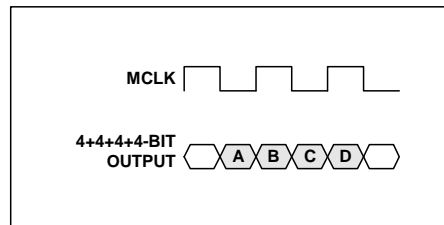

Figure 10 Output Data Formats (Modes 1, 3, 4)

OUTPUT FORMAT	OUTPUT PINS	OUTPUT
4+4+4+4-bit (nibble)	OP[3:0]	A = d15, d14, d13, d12 B = d11, d10, d9, d8 C = d7, d6, d5, d4 D = d3, d2, d1, d0

Table 2 Details of Output Data Shown in Figure 10

CONTROL INTERFACE

The internal control registers are programmable via the serial digital control interface. The register contents can be read back via the serial interface on pin OP[3]/SDO.

It is recommended that a software reset is carried out after the power-up sequence, before writing to any other register. This ensures that all registers are set to their default values (as shown in Table 4).

SERIAL INTERFACE: REGISTER WRITE

Figure 11 shows register writing in serial mode. Three pins, SCK, SDI and SEN are used. A six-bit address (a5, 0, a3, a2, a1, a0) is clocked in through SDI, MSB first, followed by an eight-bit data word (b7, b6, b5, b4, b3, b2, b1, b0), also MSB first. Each bit is latched on the rising edge of SCK. When the data has been shifted into the device, a pulse is applied to SEN to transfer the data to the appropriate internal register. Note all valid registers have address bit a4 equal to 0 in write mode.

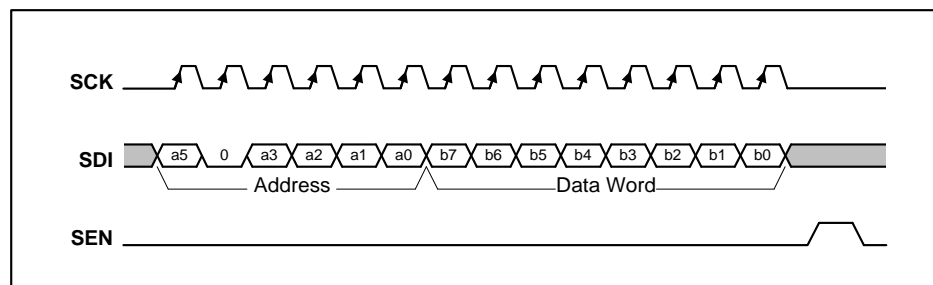

Figure 11 Serial Interface Register Write

A software reset is carried out by writing to Address "000100" with any value of data, (i.e. Data Word = XXXXXXXX).

SERIAL INTERFACE: REGISTER READ-BACK

Figure 12 shows register read-back in serial mode. Read-back is initiated by writing to the serial bus as described above but with address bit a4 set to 1, followed by an 8-bit dummy data word. Writing address (a5, 1, a3, a2, a1, a0) will cause the contents (d7, d6, d5, d4, d3, d2, d1, d0) of corresponding register (a5, 0, a3, a2, a1, a0) to be output MSB first on pin SDO (on the falling edge of SCK). Note that pin SDO is shared with an output pin, OP[3], so no data can be read when reading from a register. The next word may be read in to SDI while the previous word is still being output on SDO.

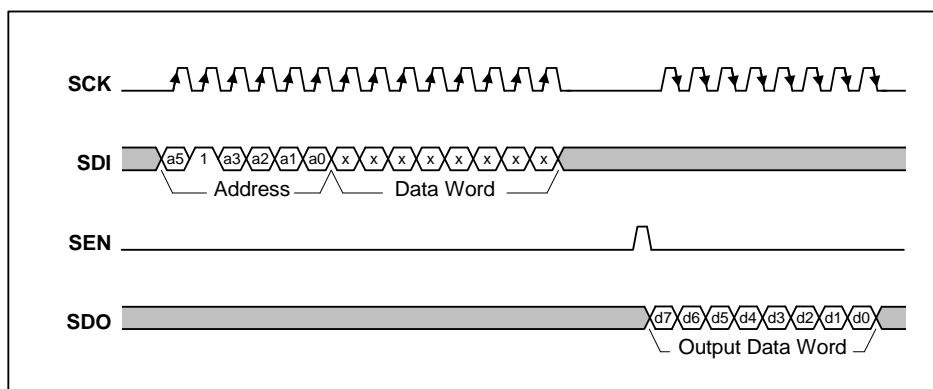

Figure 12 Serial Interface Register Read-back

TIMING REQUIREMENTS

To use this device a master clock (MCLK) of up to 36MHz and a per-pixel synchronisation clock (VSMP) of up to 6MHz are required. These clocks drive a timing control block, which produces internal signals to control the sampling of the video signal. MCLK to VSMP ratios and maximum sample rates for the various modes are shown in Table 3.

PROGRAMMABLE VSMP DETECT CIRCUIT

The VSMP input is used to determine the sampling point and frequency of the WM8253. Under normal operation a pulse of 1 MCLK period should be applied to VSMP at the desired sampling frequency (as shown in the Operating Mode Timing Diagrams) and the input sample will be taken on the first rising MCLK edge after VSMP has gone low. However, in certain applications such a signal may not be readily available. The programmable VSMP detect circuit in the WM8253 allows the sampling point to be derived from any signal of the correct frequency, such as a CCD shift register clock, when applied to the VSMP pin.

When enabled, by setting the VSMPDET control bit, the circuit detects either a rising or falling edge (determined by POSNNEG control bit) on the VSMP input pin and generates an internal VSMP pulse. This pulse can optionally be delayed by a number of MCLK periods, specified by the VDEL[2:0] bits. Figure 13 shows the internal VSMP pulses that can be generated by this circuit for a typical clock input signal. The internal VSMP pulse is then applied to the timing control block in place of the normal VSMP pulse provided from the input pin. The sampling point then occurs on the first rising MCLK edge after this internal VSMP pulse, as shown in the Operating Mode Timing Diagrams.

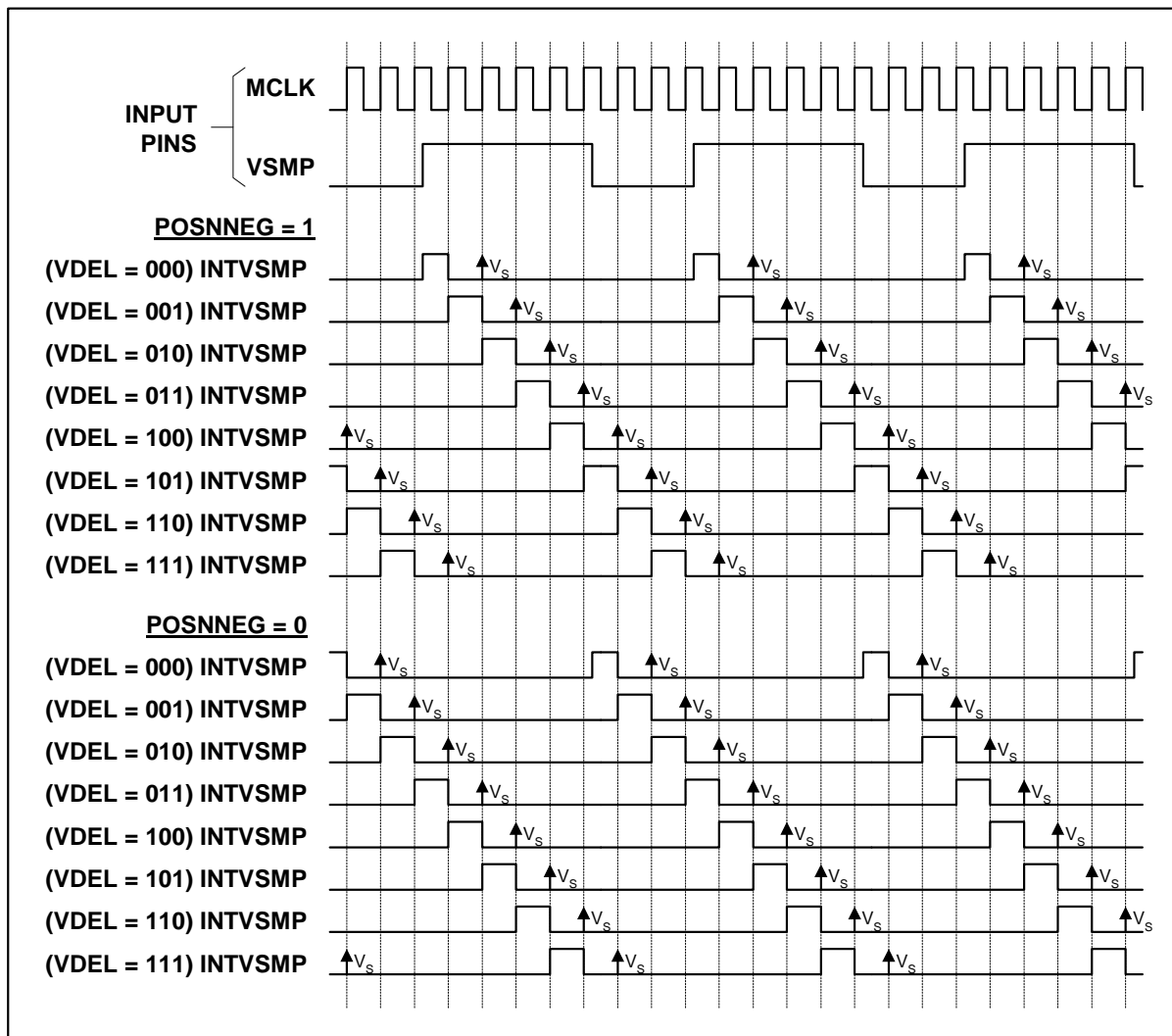

Figure 13 Internal VSMP Pulses Generated by Programmable VSMP Detect Circuit

REFERENCES

The ADC reference voltages are derived from an internal bandgap reference, and buffered to pins VRT and VRB, where they must be decoupled to ground. The output buffer from the RLCDAC also requires decoupling at pin VRLC/VBIAS when this is configured as an output.

POWER SUPPLY

The WM8253 runs from a 3.3V single supply.

POWER MANAGEMENT

Power management for the device is performed via the Control Interface. The device can be powered on or off completely by setting the EN bit low.

All the internal registers maintain their previously programmed value in power down mode and the Control Interface inputs remain active.

OPERATING MODES

Table 3 summarises the most commonly used modes, the clock waveforms required and the register contents required for CDS and non-CDS operation.

MODE	DESCRIPTION	CDS AVAILABLE	MAX SAMPLE RATE	TIMING REQUIREMENTS	REGISTER CONTENTS WITH CDS	REGISTER CONTENTS WITHOUT CDS
1	Monochrome/ Colour Line-by-Line	Yes	6MSPS	MCLK max = 36MHz MCLK:VSMP ratio is 6:1	SetReg1: 03(hex)	SetReg1: 01(hex)
2	Fast Monochrome/ Colour Line-by-Line	Yes	6MSPS	MCLK max = 18MHz MCLK:VSMP ratio is 3:1	Identical to Mode 1 plus SetReg3: bits 5:4 must be set to 0(hex)	Identical to Mode 1
3	Maximum speed Monochrome/ Colour Line-by-Line	No	6MSPS	MCLK max = 12MHz MCLK:VSMP ratio is 2:1	CDS not possible	SetReg1: 41(hex)
4	Slow Monochrome/ Colour Line-by-Line	Yes	4.5MSPS	MCLK max = 36MHz MCLK:VSMP ratio is 2^{n-1} , $n \geq 4$	Identical to Mode 1	Identical to Mode 1

Table 3 WM8253 Operating Modes

OPERATING MODE TIMING DIAGRAMS

The following diagrams show 4-bit multiplexed output data and MCLK, VSMP and input video requirements for operation of the most commonly used modes as shown in Table 3. The diagrams are identical for both CDS and non-CDS operation.

Note that for extended Mode 4 operation (MCLK:VSMP ratios of 2n:1 where n ≥ 4) the latency is given by:

$$\text{Latency (in MCLK periods)} = 16.5 + (n - 4) * 2$$

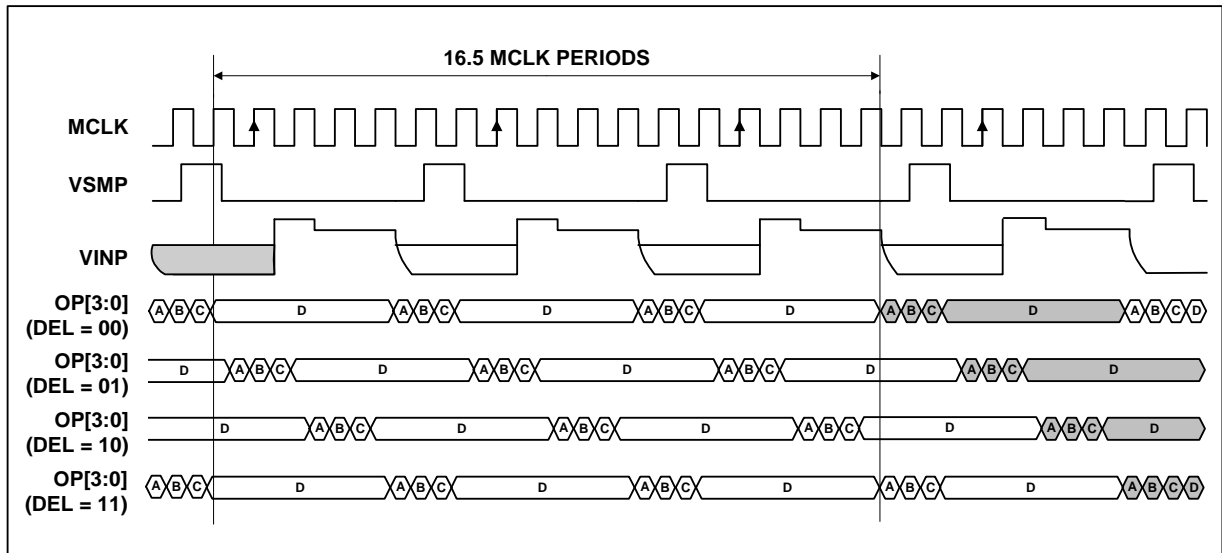

Figure 14 Mode 1 Operation

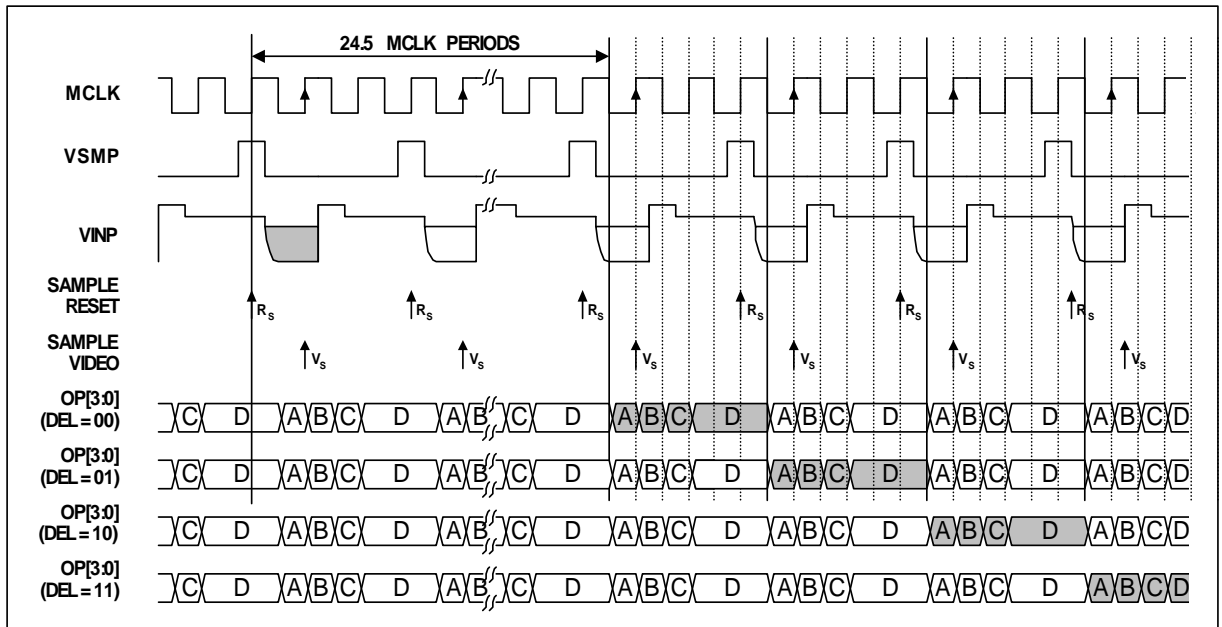

Figure 15 Mode 2 Operation

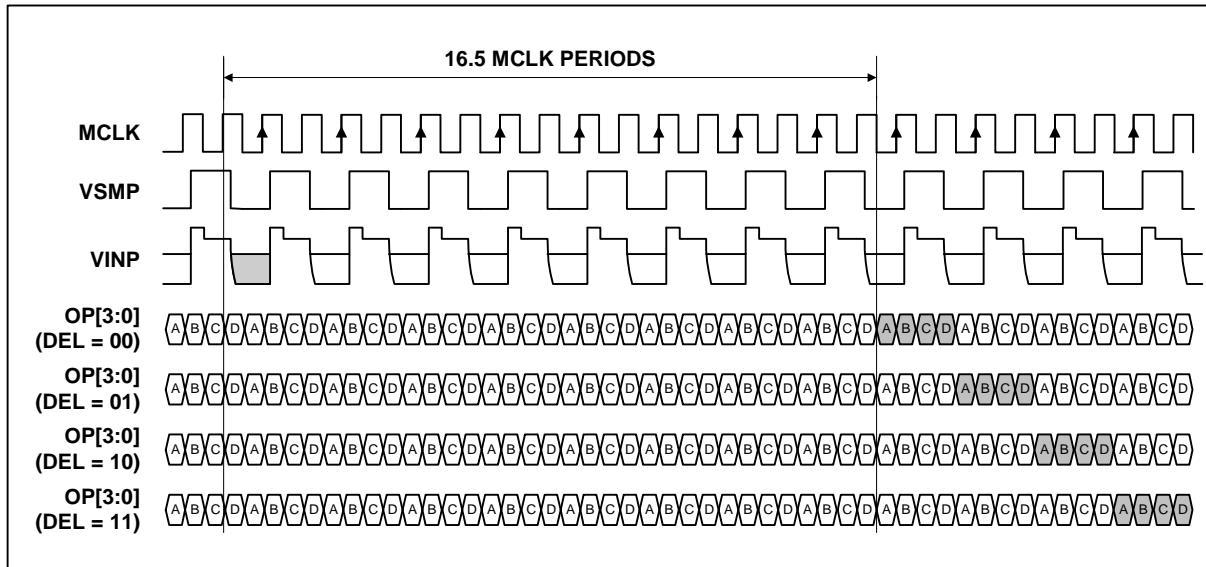

Figure 16 Mode 3 Operation

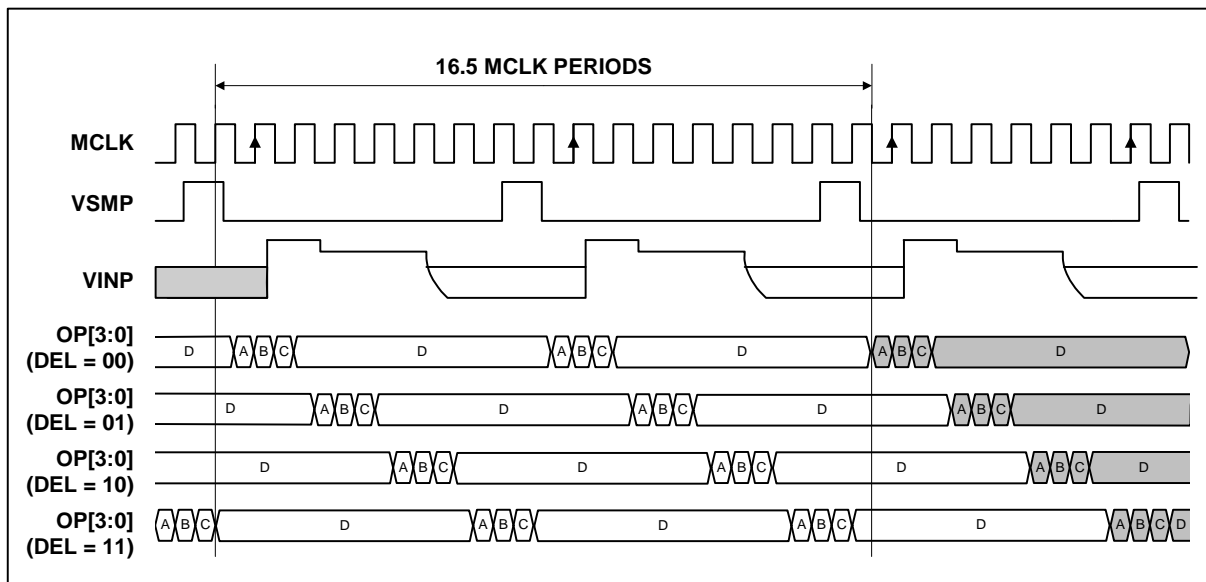

Figure 17 Mode 4 Operation (MCLK:VSMP Ratio = 8:1)

DEVICE CONFIGURATION

REGISTER MAP

The following table describes the location of each control bit used to determine the operation of the WM8253. The register map is programmed by writing the required codes to the appropriate addresses via the serial interface.

ADDRESS <a5:a0>	DESCRIPTION	DEF (hex)	RW	BIT							
				b7	b6	b5	b4	b3	b2	b1	b0
000001	Setup Reg 1	03	RW	0	MODE3	PGAFS[1]	PGAFS[0]	0	0	CDS	EN
000010	Setup Reg 2	23	RW	DEL[1]	DEL[0]	RLCDACRNG	0	VRLCEXT	INVOP	1	1
000011	Setup Reg 3	1F	RW	0	0	CDSREF [1]	CDSREF [0]	RLCV[3]	RLCV[2]	RLCV[1]	RLCV[0]
000100	Software Reset	00	W								
000110	Setup Reg 4	05	RW	0	0	INTM[1]	INTM[0]	INTRLC	1	0	1
001000	Setup Reg 5	00	RW	0	0	0	POSNEG	VDEL[2]	VDEL[1]	VDEL[0]	VSMPDET
001001	Setup Reg 6	16	RW	0	0	0	OPDLY[1]	OPDLY[0]	1	1	0
001010	Reserved	00	RW	0	0	0	0	0	0	0	0
001011	Reserved	00	RW	0	0	0	0	0	0	0	0
001100	Reserved	00	RW	0	0	0	0	0	0	0	0
001101	Reserved	00	RW	0	0	0	0	0	0	0	0
001110	Reserved	00	R	0	0	0	0	0	0	0	0
001111	Reserved	00	R	0	0	0	0	0	0	0	0
100000	DAC Value (Red)	80	RW	DACR[7]	DACR[6]	DACR[5]	DACR[4]	DACR[3]	DACR[2]	DACR[1]	DACR[0]
100001	DAC Value (Green)	80	RW	DACG[7]	DACG[6]	DACG[5]	DACG[4]	DACG[3]	DACG[2]	DACG[1]	DACG[0]
100010	DAC Value (Blue)	80	RW	DACB[7]	DACB[6]	DACB[5]	DACB[4]	DACB[3]	DACB[2]	DACB[1]	DACB[0]
100011	DAC Value (RGB)	80	W	DAC[7]	DAC[6]	DAC[5]	DAC[4]	DAC[3]	DAC[2]	DAC[1]	DAC[0]
101000	PGA Gain (Red)	00	RW	PGAR[7]	PGAR[6]	PGAR[5]	PGAR[4]	PGAR[3]	PGAR[2]	PGAR[1]	PGAR[0]
101001	PGA Gain (Green)	00	RW	PGAG[7]	PGAG[6]	PGAG[5]	PGAG[4]	PGAG[3]	PGAG[2]	PGAG[1]	PGAG[0]
101010	PGA Gain (Blue)	00	RW	PGAB[7]	PGAB[6]	PGAB[5]	PGAB[4]	PGAB[3]	PGAB[2]	PGAB[1]	PGAB[0]
101011	PGA Gain (RGB)	00	W	PGA[7]	PGA[6]	PGA[5]	PGA[4]	PGA[3]	PGA[2]	PGA[1]	PGA[0]

Table 4 Register Map

REGISTER MAP DESCRIPTION

The following table describes the function of each of the control bits shown in Table 4.

REGISTER	BIT NO	BIT NAME(S)	DEFAULT	DESCRIPTION
Setup Register 1	0	EN	1	0 = complete power down, 1 = fully active.
	1	CDS	1	Select correlated double sampling mode: 0 = single ended mode, 1 = CDS mode.
	2	Reserved	0	Must be set to zero
	3	Reserved	0	Must be set to Zero
	5:4	PGAFS[1:0]	00	Offsets PGA output to optimise the ADC range for different polarity sensor output signals. Zero differential PGA input signal gives: 00 = Zero output (use for bipolar video) 10 = Full-scale positive output (use for negative going video) 01 = Zero output (use for positive going video) 11 = Full-scale negative output (use for positive going video)
	6	MODE3	0	This bit must be set when operating in MODE3 (MCLK:VSMP=2:1) 0 = other modes, 1 = MODE3. NB, when in this mode the CDSREF bits should also be set to 01 to allow clamping to operate correctly.
	7	Reserved	0	Must be set to zero
Setup Register 2	1:0	Reserved	11	Must be set to One
	2	INVOP	0	Digitally inverts the polarity of output data. 0 = negative going video gives negative going output, 1 = negative-going video gives positive going output data.
	3	VRLCEXT	0	When set powers down the RLCDAC, changing its output to Hi-Z, allowing VRLC/VBIAS to be externally driven.
	4	Reserved	0	Must be set to Zero
	5	RLCDACRNG	1	Sets the output range of the RLCDAC. 0 = RLCDAC ranges from 0 to VDD (approximately), 1 = RLCDAC ranges from 0 to VRT (approximately).
	7:6	DEL[1:0]	00	Sets the output latency in ADC clock periods. 1 ADC clock period = 2 MCLK periods except in Mode 2 where 1 ADC clock period = 3 MCLK periods. 00 = Minimum latency 10 = Delay by two ADC clock periods 01 = Delay by one ADC clock 11 = Delay by three ADC clock periods period
Setup Register 3	3:0	RLCV[3:0]	1111	Controls RLCDAC driving VRLC pin to define single ended signal reference voltage or Reset Level Clamp voltage. See Electrical Characteristics section for ranges.
	5:4	CDSREF[1:0]	01	CDS mode reset timing adjust. 00 = Advance 1 MCLK period 10 = Retard 1 MCLK period 01 = Normal 11 = Retard 2 MCLK periods
	7:6	Reserved	00	Must be set to Zero
Software Reset				Any write to Software Reset causes all cells to be reset. It is recommended that a software reset be performed after a power-up before any other register writes.
Setup Register 4	2:0	Reserved	101	Must be set to '101'
	3	INTRLC	0	This bit is used to determine whether Reset Level Clamping is enabled. 0 = RLC disabled, 1 = RLC enabled.
	5:4	INTM[1:0]	00	Colour selection bits used in internal modes. 00 = Red, 01 = Green, 10 = Blue and 11 = Reserved. See Table 1 for details.
	7:6	Reserved	00	Must be set to Zero

REGISTER	BIT NO	BIT NAME(S)	DEFAULT	DESCRIPTION
Setup Register 5	0	VSMPDET	0	0 = Normal operation, signal on VSMP input pin is applied directly to Timing Control block. 1 = Programmable VSMP detect circuit is enabled. An internal synchronisation pulse is generated from signal applied to VSMP input pin and is applied to Timing Control block.
	3:1	VDEL[2:0]	000	When VSMPDET = 0 these bits have no effect. When VSMPDET = 1 these bits set a programmable delay from the detected edge of the signal applied to the VSMP pin. The internally generated pulse is delayed by VDEL MCLK periods from the detected edge. See Figure 13, Internal VSMP Pulses Generated for details.
	4	POSNEG	0	When VSMPDET = 0 this bit has no effect. When VSMPDET = 1 this bit controls whether positive or negative edges are detected: 0 = Negative edge on VSMP pin is detected and used to generate internal timing pulse. 1 = Positive edge on VSMP pin is detected and used to generate internal timing pulse. See Figure 13 for further details.
	7:5	Reserved	000	Must be set to Zero
Setup Register 6	0	Reserved	0	Must be set to Zero
	2:1	Reserved	11	Must be set to One
	4:3	OPDLY[1:0]	10	Programmable adjust on the output propagation time (t_{PD}) 00 = 8ns 01 = 12ns 10 = 14ns 11 = not valid
	7:5	Reserved	000	Must be set to zero
Offset DAC (Red)	7:0	DACR[7:0]	10000000	Red channel offset DAC value. Used under control of the INTM[1:0] control bits.
Offset DAC (Green)	7:0	DACG[7:0]	10000000	Green channel offset DAC value. Used under control of the INTM[1:0] control bits.
Offset DAC (Blue)	7:0	DACB[7:0]	10000000	Blue channel offset DAC value. Used under control of the INTM[1:0] control bits.
Offset DAC (RGB)	7:0	DAC[7:0]		A write to this register location causes the red, green and blue offset DAC registers to be overwritten by the new value
PGA gain (Red)	7:0	PGAR[7:0]	00000000	Determines the gain of the red channel PGA according to the equation: Red channel PGA gain = $[0.78+(PGAR[7:0]*7.57)/255]$. Used under control of the INTM[1:0] control bits.
PGA gain (Green)	7:0	PGAG[7:0]	00000000	Determines the gain of the green channel PGA according to the equation: Green channel PGA gain = $[0.78+(PGAG[7:0]*7.57)/255]$. Used under control of the INTM[1:0] control bits.
PGA gain (Blue)	7:0	PGAB[7:0]	00000000	Determines the gain of the blue channel PGA according to the equation: Blue channel PGA gain = $[0.78+(PGAB[7:0]*7.57)/255]$. Used under control of the INTM[1:0] control bits.
PGA gain (RGB)	7:0	PGA[7:0]		A write to this register location causes the red, green and blue PGA gain registers to be overwritten by the new value

Table 5 Register Control Bits

RECOMMENDED EXTERNAL COMPONENTS

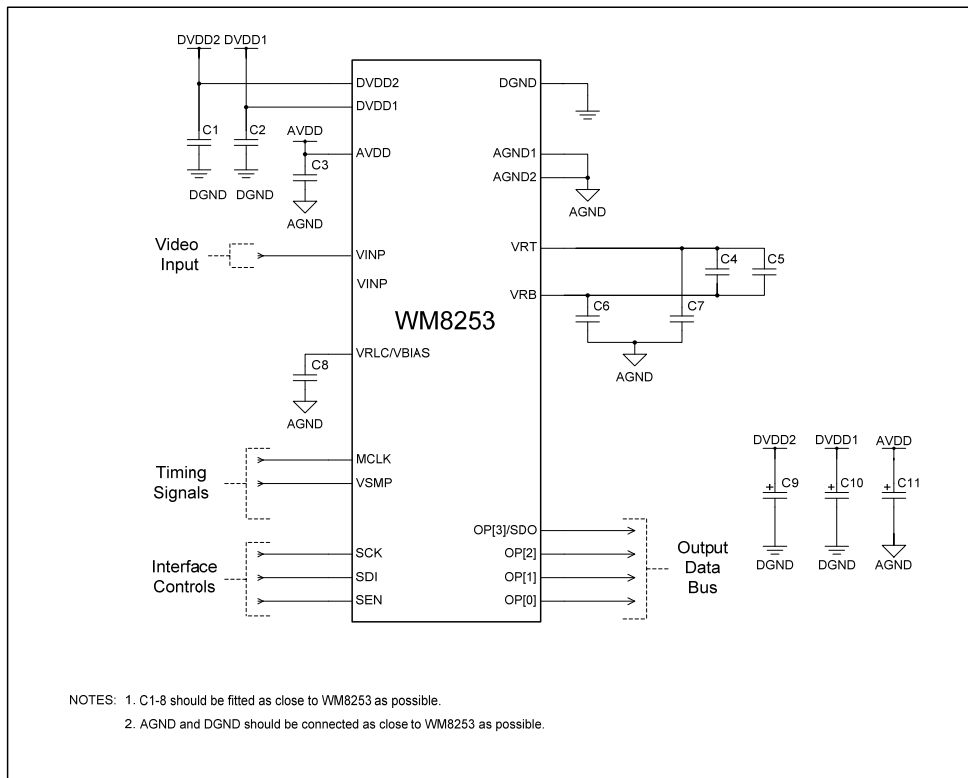
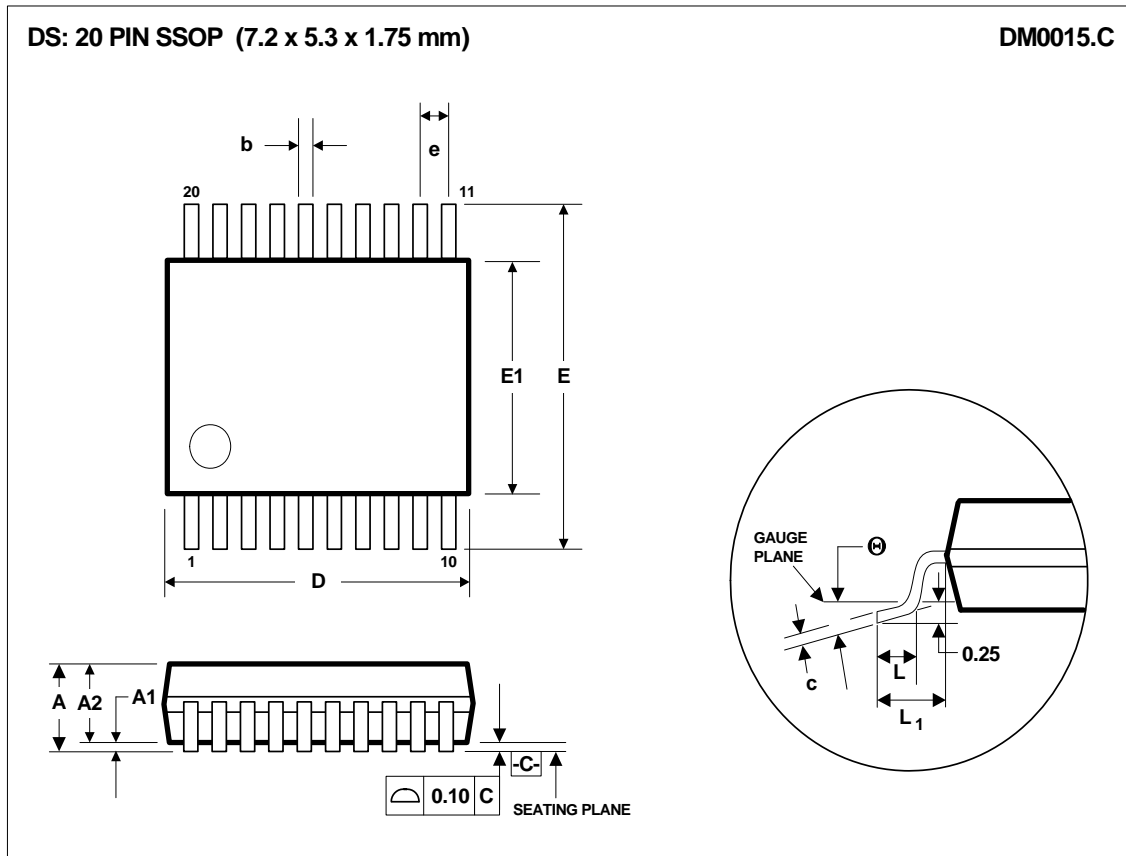

Figure 18 External Components Diagram

COMPONENT REFERENCE	SUGGESTED VALUE	DESCRIPTION
C1	100nF	De-coupling for DVDD2.
C2	100nF	De-coupling for DVDD1.
C3	100nF	De-coupling for AVDD.
C4	10nF	High frequency de-coupling between VRT and VRB.
C5	1µF	Low frequency de-coupling between VRT and VRB (non-polarised).
C6	100nF	De-coupling for VRB.
C7	100nF	De-coupling for VRT.
C8	100nF	De-coupling for VRLC.
C9	10µF	Reservoir capacitor for DVDD2.
C10	10µF	Reservoir capacitor for DVDD1.
C11	10µF	Reservoir capacitor for AVDD.
C12	200pF	Input coupling capacitor

Table 6 External Components Descriptions

PACKAGE DIMENSIONS



Symbols	Dimensions (mm)		
	MIN	NOM	MAX
A	-----	-----	2.0
A₁	0.05	-----	-----
A₂	1.65	1.75	1.85
b	0.22	0.30	0.38
c	0.09	-----	0.25
D	6.90	7.20	7.50
e	0.65 BSC		
E	7.40	7.80	8.20
E₁	5.00	5.30	5.60
L	0.55	0.75	0.95
L₁	1.25 REF		
θ	0°	4°	8°
REF:	JEDEC.95, MO-150		

- NOTES:
- A. ALL LINEAR DIMENSIONS ARE IN MILLIMETERS.
 - B. THIS DRAWING IS SUBJECT TO CHANGE WITHOUT NOTICE.
 - C. BODY DIMENSIONS DO NOT INCLUDE MOLD FLASH OR PROTRUSION, NOT TO EXCEED 0.20MM.
 - D. MEETS JEDEC.95 MO-150, VARIATION = AE. REFER TO THIS SPECIFICATION FOR FURTHER DETAILS.

IMPORTANT NOTICE

Wolfson Microelectronics plc ("Wolfson") products and services are sold subject to Wolfson's terms and conditions of sale, delivery and payment supplied at the time of order acknowledgement.

Wolfson warrants performance of its products to the specifications in effect at the date of shipment. Wolfson reserves the right to make changes to its products and specifications or to discontinue any product or service without notice. Customers should therefore obtain the latest version of relevant information from Wolfson to verify that the information is current.

Testing and other quality control techniques are utilised to the extent Wolfson deems necessary to support its warranty. Specific testing of all parameters of each device is not necessarily performed unless required by law or regulation.

In order to minimise risks associated with customer applications, the customer must use adequate design and operating safeguards to minimise inherent or procedural hazards. Wolfson is not liable for applications assistance or customer product design. The customer is solely responsible for its selection and use of Wolfson products. Wolfson is not liable for such selection or use nor for use of any circuitry other than circuitry entirely embodied in a Wolfson product.

Wolfson's products are not intended for use in life support systems, appliances, nuclear systems or systems where malfunction can reasonably be expected to result in personal injury, death or severe property or environmental damage. Any use of products by the customer for such purposes is at the customer's own risk.

Wolfson does not grant any licence (express or implied) under any patent right, copyright, mask work right or other intellectual property right of Wolfson covering or relating to any combination, machine, or process in which its products or services might be or are used. Any provision or publication of any third party's products or services does not constitute Wolfson's approval, licence, warranty or endorsement thereof. Any third party trade marks contained in this document belong to the respective third party owner.

Reproduction of information from Wolfson datasheets is permissible only if reproduction is without alteration and is accompanied by all associated copyright, proprietary and other notices (including this notice) and conditions. Wolfson is not liable for any unauthorised alteration of such information or for any reliance placed thereon.

Any representations made, warranties given, and/or liabilities accepted by any person which differ from those contained in this datasheet or in Wolfson's standard terms and conditions of sale, delivery and payment are made, given and/or accepted at that person's own risk. Wolfson is not liable for any such representations, warranties or liabilities or for any reliance placed thereon by any person.

ADDRESS:

Wolfson Microelectronics plc
Westfield House
26 Westfield Road
Edinburgh
EH11 2QB
United Kingdom

Tel :: +44 (0)131 272 7000

Fax :: +44 (0)131 272 7001

Email :: sales@wolfsonmicro.com

REVISION HISTORY

DATE	REV	ORIGINATOR	CHANGES
18/09/07	4.0	JP	Page 6 Changed minimum ADC Full-Scale Error from -50mV to -60mV Changed maximum ADC Full-Scale Error from +50mV to +60mV Changed the minimum value of PGA's maximum gain from 8.0 to 8.2 Changed the maximum value of PGA's maximum gain from 8.7 to 8.8 Changed the maximum value of PGA's minimum gain from 0.84 to 0.87
29/08/11	4.1	AA	Page 22 Register Map Description: Setup Register 1 (6) – deleted INTRLC =1 from description Setup Register 4 (3) – changed RLCINT to INTRLC

Mouser Electronics

Authorized Distributor

Click to View Pricing, Inventory, Delivery & Lifecycle Information:

[Cirrus Logic:](#)

[WM8253SCDS/V](#) [WM8253SCDS/RV](#)



Компания «ЭлектроПласт» предлагает заключение долгосрочных отношений при поставках импортных электронных компонентов на взаимовыгодных условиях!

Наши преимущества:

- Оперативные поставки широкого спектра электронных компонентов отечественного и импортного производства напрямую от производителей и с крупнейших мировых складов;
- Поставка более 17-ти миллионов наименований электронных компонентов;
- Поставка сложных, дефицитных, либо снятых с производства позиций;
- Оперативные сроки поставки под заказ (от 5 рабочих дней);
- Экспресс доставка в любую точку России;
- Техническая поддержка проекта, помощь в подборе аналогов, поставка прототипов;
- Система менеджмента качества сертифицирована по Международному стандарту ISO 9001;
- Лицензия ФСБ на осуществление работ с использованием сведений, составляющих государственную тайну;
- Поставка специализированных компонентов (Xilinx, Altera, Analog Devices, Intersil, Interpoint, Microsemi, Aeroflex, Peregrine, Syfer, Eurofarad, Texas Instrument, Miteq, Cobham, E2V, MA-COM, Hittite, Mini-Circuits, General Dynamics и др.);

Помимо этого, одним из направлений компании «ЭлектроПласт» является направление «Источники питания». Мы предлагаем Вам помощь Конструкторского отдела:

- Подбор оптимального решения, техническое обоснование при выборе компонента;
- Подбор аналогов;
- Консультации по применению компонента;
- Поставка образцов и прототипов;
- Техническая поддержка проекта;
- Защита от снятия компонента с производства.



Как с нами связаться

Телефон: 8 (812) 309 58 32 (многоканальный)

Факс: 8 (812) 320-02-42

Электронная почта: org@eplast1.ru

Адрес: 198099, г. Санкт-Петербург, ул. Калинина, дом 2, корпус 4, литера А.