

Features

- Serial Peripheral Interface (SPI) Compatible
- Supports SPI Modes 0 (0,0) and 3 (1,1)
 - Datasheet Describes Mode 0 Operation
- Low-voltage and standard-voltage Operation
 - 1.8V ($V_{CC} = 1.8V$ to 5.5V)
- 20MHz Clock Rate (5V)
- 32-byte Page Mode
- Block Write Protection
 - Protect 1/4, 1/2, or Entire Array
- Write Protect (\overline{WP}) Pin and Write Disable Instructions for Both Hardware and Software Data Protection
- Self-timed Write Cycle (5ms Max)
- High Reliability
 - Endurance: 1,000,000 Write Cycles
 - Data Retention: 100 Years
- Green (Pb/Halide-free/RoHS Compliant) Packaging Options
- Die Sales: Wafer Form, Tape and Reel, and Bumped Wafers

Description

The Atmel® AT25320B/640B provides 32,768-/65,536-bits of Serial Electrically-Erasable Programmable Read-Only Memory (EEPROM) organized as 4,096/8,192 words of 8 bits each. The device is optimized for use in many industrial and commercial applications where low-power and low-voltage operation are essential. The AT25320B/640B is available in space-saving 8-lead JEDEC SOIC, 8-lead TSSOP, 8-lead UDFN, 8-lead XDFN, and 8-ball VFBGA packages.

The AT25320B/640B is enabled through the Chip Select pin (\overline{CS}) and accessed via a 3-wire interface consisting of Serial Data Input (SI), Serial Data Output (SO), and Serial Clock (SCK). All programming cycles are completely self-timed, and no separate erase cycle is required before Write.

Block Write Protection is enabled by programming the status register with one of four blocks of write protection. Separate Program Enable and Program Disable instructions are provided for additional data protection. Hardware data protection is provided via the \overline{WP} pin to protect against inadvertent write attempts to the status register. The \overline{HOLD} pin may be used to suspend any serial communication without resetting the serial sequence.

1. Pin Configurations and Pinouts

Table 1-1. Pin Configurations

Pin Name	Function
$\overline{\text{CS}}$	Chip Select
SCK	Serial Data Clock
SI	Serial Data Input
SO	Serial Data Output
GND	Ground
V_{CC}	Power Supply
$\overline{\text{WP}}$	Write Protect
HOLD	Suspends Serial Input

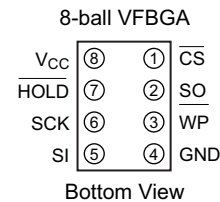
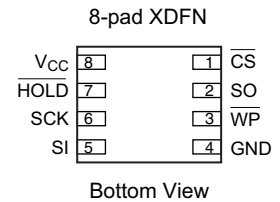
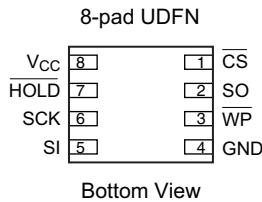
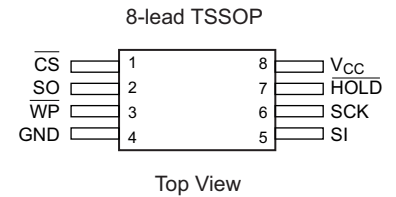
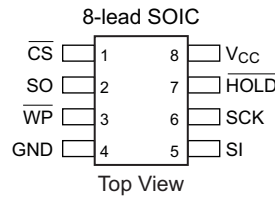

Note: Drawings are not to scale.

2. Absolute Maximum Ratings*

Operating Temperature	-55°C to +125°C
Storage Temperature	-65°C to +150°C
Voltage on Any Pin with Respect to Ground	-1.0V to +7.0V
Maximum Operating Voltage	6.25V
DC Output Current	5.0mA

*Notice: Stresses beyond those listed under “Absolute Maximum Ratings” may cause permanent damage to the device. This is a stress rating only and functional operation of the device at these or any other conditions beyond those indicated in the operational sections of this specification is not implied. Exposure to absolute maximum rating conditions for extended periods may affect device reliability.

3. Block Diagram

Figure 3-1. Block Diagram

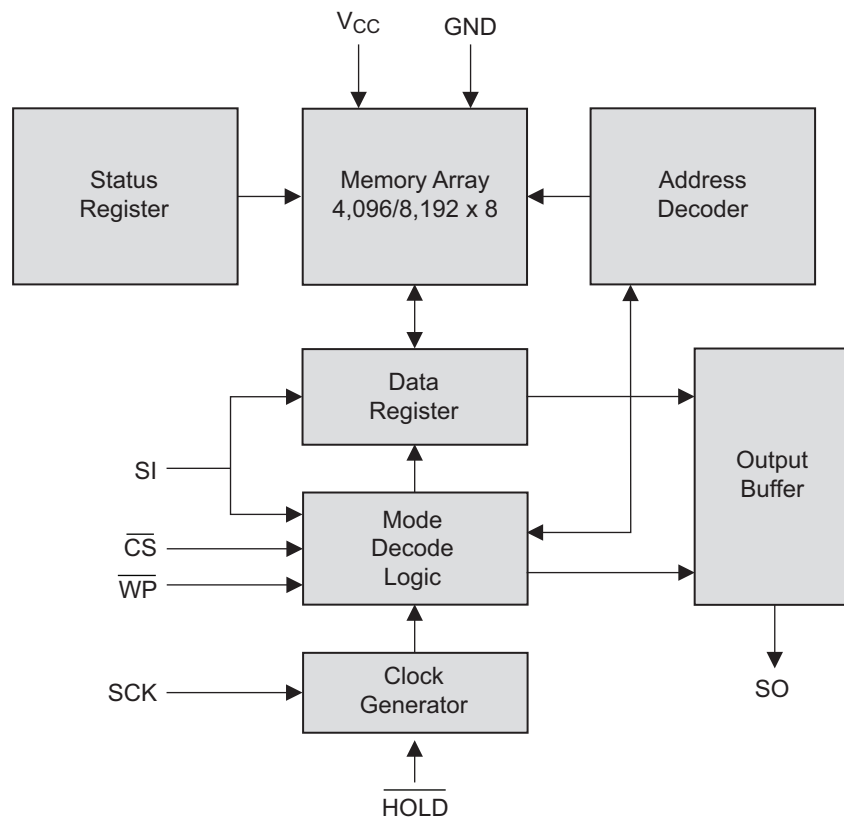

4. Electrical Characteristics

4.1 Pin Capacitance

Table 4-1. Pin Capacitance⁽¹⁾

Applicable over recommended operating range from $T_A = 25^\circ\text{C}$, $f = 1.0\text{MHz}$, $V_{CC} = 5.0\text{V}$ (unless otherwise noted).

Symbol	Test Conditions	Max	Units	Conditions
C_{OUT}	Output Capacitance (SO)	8	pF	$V_{OUT} = 0\text{V}$
C_{IN}	Input Capacitance (\overline{CS} , SCK, SI, \overline{WP} , \overline{HOLD})	6	pF	$V_{IN} = 0\text{V}$

Note: 1. This parameter is characterized and is not 100% tested.

4.2 DC Characteristics

Table 4-2. DC Characteristics

Applicable over recommended operating range from: $T_{AI} = -40^\circ\text{C}$ to $+85^\circ\text{C}$, $V_{CC} = 1.8\text{V}$ to 5.5V (unless otherwise noted).

Symbol	Parameter	Test Condition	Min	Typ	Max	Units
V_{CC1}	Supply Voltage		1.8		5.5	V
V_{CC2}	Supply Voltage		2.5		5.5	V
V_{CC3}	Supply Voltage		4.5		5.5	V
I_{CC1}	Supply Current	$V_{CC} = 5.0\text{V}$ at 20MHz, SO = Open, Read		7.5	10.0	mA
I_{CC2}	Supply Current	$V_{CC} = 5.0\text{V}$ at 20MHz, SO = Open, Read, Write		4.0	10.0	mA
I_{CC3}	Supply Current	$V_{CC} = 5.0\text{V}$ at 5MHz, SO = Open, Read, Write		4.0	6.0	mA
I_{SB1}	Standby Current	$V_{CC} = 1.8\text{V}$, $\overline{CS} = V_{CC}$		< 0.1	6.0 ⁽²⁾	μA
I_{SB2}	Standby Current	$V_{CC} = 2.5\text{V}$, $\overline{CS} = V_{CC}$		0.3	7.0 ⁽²⁾	μA
I_{SB3}	Standby Current	$V_{CC} = 5.0\text{V}$, $\overline{CS} = V_{CC}$		2.0	10.0 ⁽²⁾	μA
I_{IL}	Input Leakage	$V_{IN} = 0\text{V}$ to V_{CC}	-3.0		3.0	μA
I_{OL}	Output Leakage	$V_{IN} = 0\text{V}$ to V_{CC} , $T_{AC} = 0^\circ\text{C}$ to 70°C	-3.0		3.0	μA
$V_{IL}^{(1)}$	Input Low-voltage		-0.6		$V_{CC} \times 0.3$	V
$V_{IH}^{(1)}$	Input High-voltage		$V_{CC} \times 0.7$		$V_{CC} + 0.5$	V
V_{OL1}	Output Low-voltage	$3.6\text{V} \leq V_{CC} \leq 5.5\text{V}$			0.4	V
V_{OH1}	Output High-voltage			$I_{OH} = -1.6\text{mA}$	$V_{CC} - 0.8$	V
V_{OL2}	Output Low-voltage	$1.8\text{V} \leq V_{CC} \leq 3.6\text{V}$			0.2	V
V_{OH2}	Output High-voltage			$I_{OH} = -100\mu\text{A}$	$V_{CC} - 0.2$	V

Notes: 1. V_{IL} min and V_{IH} max are reference only and are not tested.
2. Worst case measured at 85°C .

4.3 AC Characteristics

Table 4-3. AC Characteristics

Applicable over recommended operating range from $T_{AI} = -40^{\circ}\text{C}$ to $+85^{\circ}\text{C}$, $V_{CC} = \text{As Specified}$, $CL = 1$ TTL Gate and 30pF (unless otherwise noted).

Symbol	Parameter	Voltage	Min	Max	Units
f_{SCK}	SCK Clock Frequency	4.5 – 5.5	0	20	MHz
		2.5 – 5.5	0	10	
		1.8 – 5.5	0	5	
t_{RI}	Input Rise Time	4.5 – 5.5		2	μs
		2.5 – 5.5		2	
		1.8 – 5.5		2	
t_{FI}	Input Fall Time	4.5 – 5.5		2	μs
		2.5 – 5.5		2	
		1.8 – 5.5		2	
t_{WH}	SCK High Time	4.5 – 5.5	20		ns
		2.5 – 5.5	40		
		1.8 – 5.5	80		
t_{WL}	SCK Low Time	4.5 – 5.5	20		ns
		2.5 – 5.5	40		
		1.8 – 5.5	80		
t_{CS}	$\overline{\text{CS}}$ High Time	4.5 – 5.5	25		ns
		2.5 – 5.5	50		
		1.8 – 5.5	100		
t_{CSS}	$\overline{\text{CS}}$ Setup Time	4.5 – 5.5	25		ns
		2.5 – 5.5	50		
		1.8 – 5.5	100		
t_{CSH}	$\overline{\text{CS}}$ Hold Time	4.5 – 5.5	25		ns
		2.5 – 5.5	50		
		1.8 – 5.5	100		
t_{SU}	Data In Setup Time	4.5 – 5.5	5		ns
		2.5 – 5.5	10		
		1.8 – 5.5	20		
t_{HI}	Data In Hold Time	4.5 – 5.5	5		ns
		2.5 – 5.5	10		
		1.8 – 5.5	20		
t_{HD}	$\overline{\text{HOLD}}$ Setup Time	4.5 – 5.5	5		
		2.5 – 5.5	10		
		1.8 – 5.5	20		
t_{CD}	$\overline{\text{HOLD}}$ Hold Time	4.5 – 5.5	5		ns
		2.5 – 5.5	10		
		1.8 – 5.5	20		
t_V	Output Valid	4.5 – 5.5	0	20	ns
		2.5 – 5.5	0	40	
		1.8 – 5.5	0	80	
t_{HO}	Output Hold Time	4.5 – 5.5	0		ns
		2.5 – 5.5	0		
		1.8 – 5.5	0		

Table 4-3. AC Characteristics (Continued)

Applicable over recommended operating range from $T_{AI} = -40^{\circ}\text{C}$ to $+85^{\circ}\text{C}$, $V_{CC} = \text{As Specified}$, $CL = 1$ TTL Gate and 30pF (unless otherwise noted).

Symbol	Parameter	Voltage	Min	Max	Units
t_{LZ}	$\overline{\text{HOLD}}$ to Output Low Z	4.5 – 5.5	0	25	ns
		2.5 – 5.5	0	50	
		1.8 – 5.5	0	100	
t_{HZ}	$\overline{\text{HOLD}}$ to Output High Z	4.5 – 5.5		40	ns
		2.5 – 5.5		80	
		1.8 – 5.5		200	
t_{DIS}	Output Disable Time	4.5 – 5.5		40	ns
		2.5 – 5.5		80	
		1.8 – 5.5		200	
t_{WC}	Write Cycle Time	4.5 – 5.5		5	ms
		2.5 – 5.5		5	
		1.8 – 5.5		5	
Endurance ⁽¹⁾	3.3V, 25°C, Page Mode	4.5 – 5.5 2.5 – 5.5 1.8 – 5.5	1,000,000		Write Cycles

Note: 1. This parameter is characterized and is not 100% tested.

5. Serial Interface Description

Master: The device that generates the serial clock.

Slave: Because the Serial Clock pin (SCK) is always an input, the AT25320B/640B always operates as a slave.

Transmitter/receiver: The AT25320B/640B has separate pins designated for data transmission (SO) and reception (SI).

MSB: The Most Significant Bit (MSB) is the first bit transmitted and received.

Serial Opcode: After the device is selected with $\overline{\text{CS}}$ going low, the first byte will be received. This byte contains the opcode that defines the operations to be performed.

Invalid Opcode: If an invalid opcode is received, no data will be shifted into the AT25320B/640B, and the Serial Output pin (SO) will remain in a high-impedance state until the falling edge of $\overline{\text{CS}}$ is detected again. This will reinitialize the serial communication.

Chip Select: The AT25320B/640B is selected when the $\overline{\text{CS}}$ pin is low. When the device is not selected, data will not be accepted via the SI pin, and the Serial Output pin (SO) will remain in a high-impedance state.

Hold: The $\overline{\text{HOLD}}$ pin is used in conjunction with the $\overline{\text{CS}}$ pin to pause the AT25320B/640B. When the device is selected and a serial sequence is underway, $\overline{\text{HOLD}}$ can be used to pause the serial communication with the master device without resetting the serial sequence. To pause, the $\overline{\text{HOLD}}$ pin must be brought low while the SCK pin is low. To resume serial communication, the $\overline{\text{HOLD}}$ pin is brought high while the SCK pin is low (SCK may still toggle during $\overline{\text{HOLD}}$). Inputs to the SI pin will be ignored while the SO pin is in the high-impedance state.

Write Protect: The Write Protect pin ($\overline{\text{WP}}$) will allow normal read/write operations when held high. When the WP pin is brought low and WPEN bit is one, all write operations to the status register are inhibited. $\overline{\text{WP}}$ going low while $\overline{\text{CS}}$ is still low will interrupt a Write to the status register. If the internal write cycle has already been initiated, $\overline{\text{WP}}$ going low will have no effect on any write operation to the status register. The $\overline{\text{WP}}$ pin function is blocked when the WPEN bit in the status register is zero. This will allow the user to install the AT25320B/640B in a system with the $\overline{\text{WP}}$ pin tied to ground and still be able to write to the status register. All $\overline{\text{WP}}$ pin functions are enabled when the WPEN bit is set to one.

Figure 5-1. SPI Serial Interface

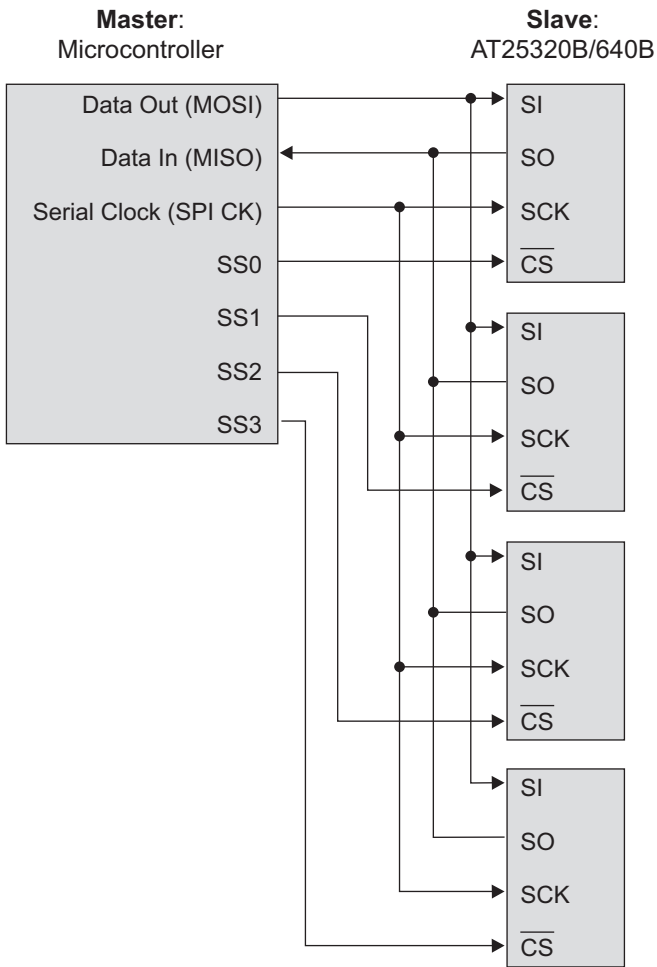

6. Functional Description

The AT25320B/640B is designed to interface directly with the synchronous Serial Peripheral Interface (SPI) of the 6805 and 68HC11 series of microcontrollers.

The AT25320B/640B utilizes an 8-bit instruction register. The list of instructions and their operation codes are contained in [Table 6-1](#). All instructions, addresses, and data are transferred with the MSB first and start with a high-to-low CS transition.

Table 6-1. Instruction Set

Instruction Name	Instruction Format	Operation
WREN	0000 X110	Set Write Enable Latch
WRDI	0000 X100	Reset Write Enable Latch
RDSR	0000 X101	Read Status Register
WRSR	0000 X001	Write Status Register
READ	0000 X011	Read Data from Memory Array
WRITE	0000 X010	Write Data to Memory Array

Write Enable (WREN): The device will power-up in the write disable state when V_{CC} is applied. All programming instructions must therefore be preceded by a Write Enable instruction.

Write Disable (WRDI): To protect the device against inadvertent writes, the Write Disable instruction disables all programming modes. The WRDI instruction is independent of the status of the \overline{WP} pin.

Read Status Register (RDSR): The Read Status Register instruction provides access to the status register. The Ready/Busy and Write Enable status of the device can be determined by the RDSR instruction. Similarly, the Block Write Protection Bits indicate the extent of protection employed. These bits are set by using the WRSR instruction.

Table 6-2. Status Register Format

Bit 7	Bit 6	Bit 5	Bit 4	Bit 3	Bit 2	Bit 1	Bit 0
WPEN	X	X	X	BP1	BP0	WEN	\overline{RDY}

Table 6-3. Read Status Register Bit Definition

Bit	Definition
Bit 0 (\overline{RDY})	Bit 0 = 0 (\overline{RDY}) indicates the device is READY. Bit 0 = 1 indicates the write cycle is in progress.
Bit 1 (WEN)	Bit 1 = 0 indicates the device is not WRITE ENABLED. Bit 1 = 1 indicates the device is write enabled.
Bit 2 (BP0)	See Table 6-4 on page 9 .
Bit 3 (BP1)	See Table 6-4 on page 9 .
Bits 4 – 6 are zeros when device is not in an internal write cycle.	
Bit 7 (WPEN)	See Table 6-5 on page 9 .
Bits 0 – 7 are ones during an internal write cycle.	

Write Status Register (WRSR): The WRSR instruction allows the user to select one of four levels of protection. The AT25320B/640B is divided into four array segments. One-quarter, one-half, or all of the memory segments can be protected. Any of the data within any selected segment will therefore be read-only. The Block Write Protection levels and corresponding status register control bits are shown in [Table 6-4](#).

The three bits BP0, BP1, and WPEN are nonvolatile cells that have the same properties and functions as the regular memory cells (e.g., WREN, t_{WC} , RDSR).

Table 6-4. Block Write Protect Bits

Level	Status Register Bits		Array Addresses Protected	
	BP1	BP0	AT25320B	AT25640B
0	0	0	None	None
1(1/4)	0	1	0C00–0FFF	1800–1FFF
2(1/2)	1	0	0800–0FFF	1000–1FFF
3(All)	1	1	0000–0FFF	0000–1FFF

The WRSR instruction also allows the user to enable or disable the Write Protect (\overline{WP}) pin through the use of the Write Protect Enable (WPEN) bit. Hardware Write Protection is enabled when the \overline{WP} pin is low and the WPEN bit is one. Hardware Write Protection is disabled when either the \overline{WP} pin is high or the WPEN bit is zero. When the device is hardware write protected, writes to the status register, including the Block Protect bits and the WPEN bit, and the block-protected sections in the memory array are disabled. Writes are only allowed to sections of the memory that are not block-protected.

Note: When the WPEN bit is Hardware Write Protected, it cannot be changed back to zero as long as the \overline{WP} pin is held low.

Table 6-5. WPEN Operation

WPEN	\overline{WP}	WEN	Protected Blocks	Unprotected Blocks	Status Register
0	X	0	Protected	Protected	Protected
0	X	1	Protected	Writeable	Writeable
1	Low	0	Protected	Protected	Protected
1	Low	1	Protected	Writeable	Protected
X	High	0	Protected	Protected	Protected
X	High	1	Protected	Writeable	Writeable

Read Sequence (READ): Reading the AT25320B/640B via the Serial Output (SO) pin requires the following sequence. After the \overline{CS} line is pulled low to select a device, the Read opcode is transmitted via the SI line followed by the byte address to be read (A15 – A0, see Table 6-6). Upon completion, any data on the SI line will be ignored. The data (D7 – D0) at the specified address is then shifted out onto the SO line. If only one byte is to be read, the \overline{CS} line should be driven high after the data comes out. The read sequence can be continued since the byte address is automatically incremented and data will continue to be shifted out. When the highest address is reached, the address counter will roll over to the lowest address allowing the entire memory to be read in one continuous read cycle.

Write Sequence (WRITE): In order to program the AT25320B/640B, two separate instructions must be executed. First, the device **must be write enabled** via the WREN instruction. Then a Write instruction may be executed. Also, the address of the memory location(s) to be programmed must be outside the protected address field location selected by the Block Write Protection level. During an internal write cycle, all commands will be ignored except the RDSR instruction.

A Write instruction requires the following sequence. After the \overline{CS} line is pulled low to select the device, the Write opcode is transmitted via the SI line followed by the byte address (A15 – A0) and the data (D7 – D0) to be programmed (see Table 6-6). Programming will start after the \overline{CS} pin is brought high. The low-to-high transition of the \overline{CS} pin must occur during the SCK low-time immediately after clocking in the D0 (LSB) data bit.

The Ready/Busy status of the device can be determined by initiating a Read Status Register (RDSR) instruction. If Bit 0 = 1, the write cycle is still in progress. If Bit 0 = 0, the write cycle has ended. Only the RDSR instruction is enabled during the write programming cycle.

The AT25320B/640B is capable of a 32-byte page write operation. After each byte of data is received, the five low-order address bits are internally incremented by one; the high-order bits of the address will remain constant. If more than 32-bytes of data are transmitted, the address counter will rollover and the previously written data will be overwritten. The AT25320B/640B is automatically returned to the write disable state at the completion of a write cycle.

Note: If the device is not Write-enabled (WREN), the device will ignore the write instruction and will return to the standby state, when \overline{CS} is brought high. A new \overline{CS} falling edge is required to reinitiate the serial communication.

Table 6-6. Address Key

Address	AT25320B	AT25640B
A_N	$A_{11}-A_0$	$A_{12}-A_0$
Don't Care Bits	$A_{15}-A_{12}$	$A_{15}-A_{13}$

7. Timing Diagrams

Figure 7-1. Synchronous Data Timing (for Mode 0)

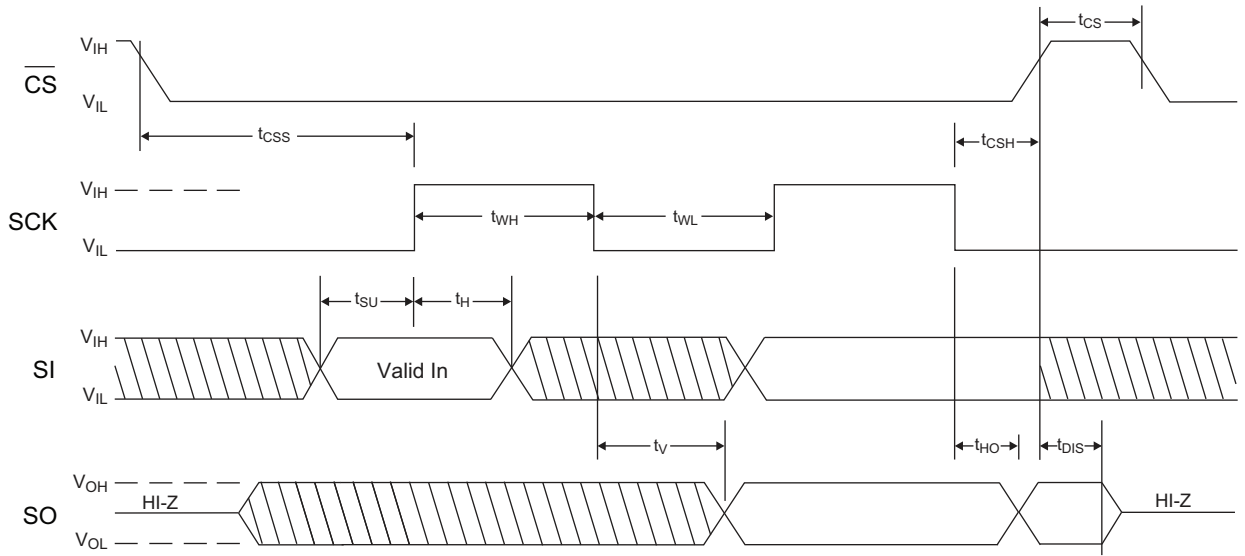

Figure 7-2. WREN Timing

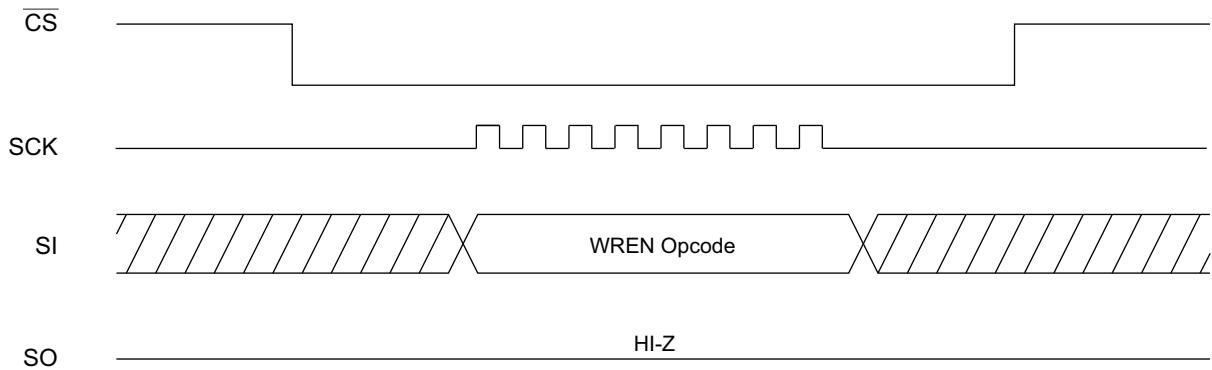

Figure 7-3. WRDI Timing

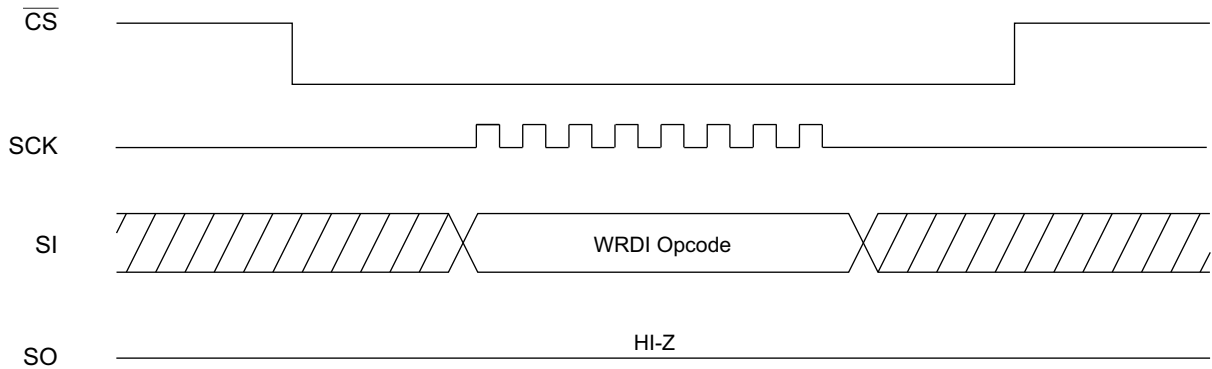

Figure 7-4. RDSR Timing

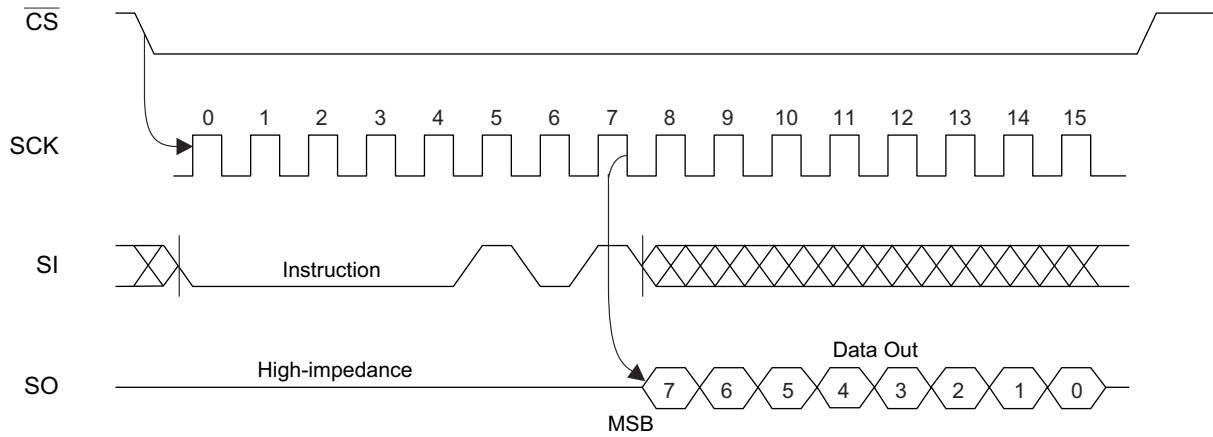

Figure 7-5. WRSR Timing

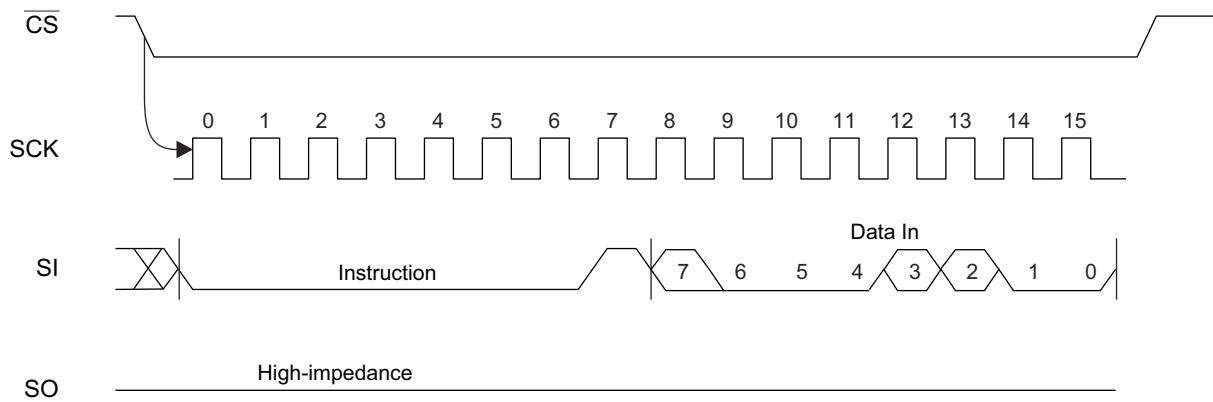

Figure 7-6. Read Timing

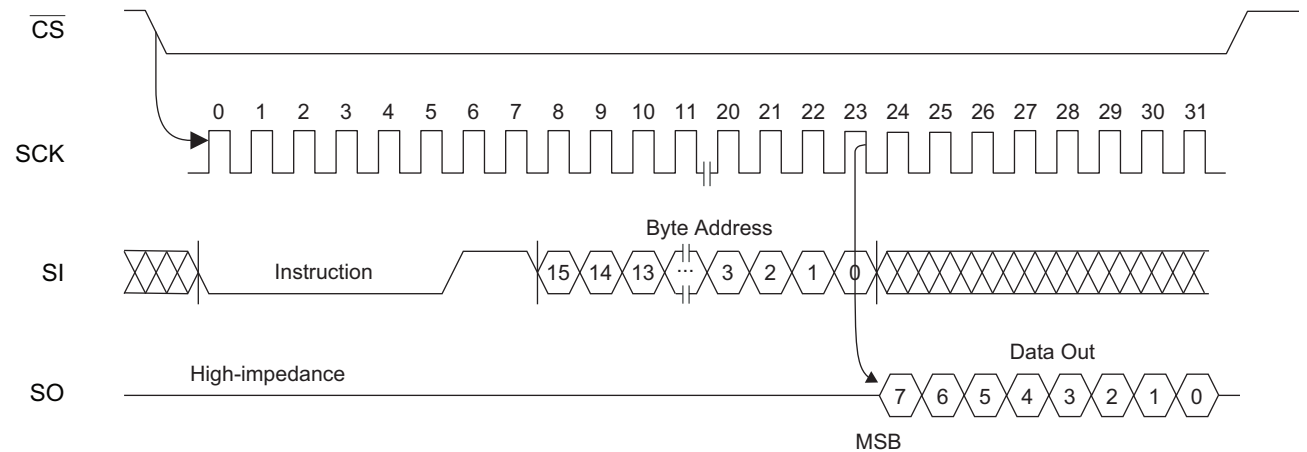

Figure 7-7. Write Timing

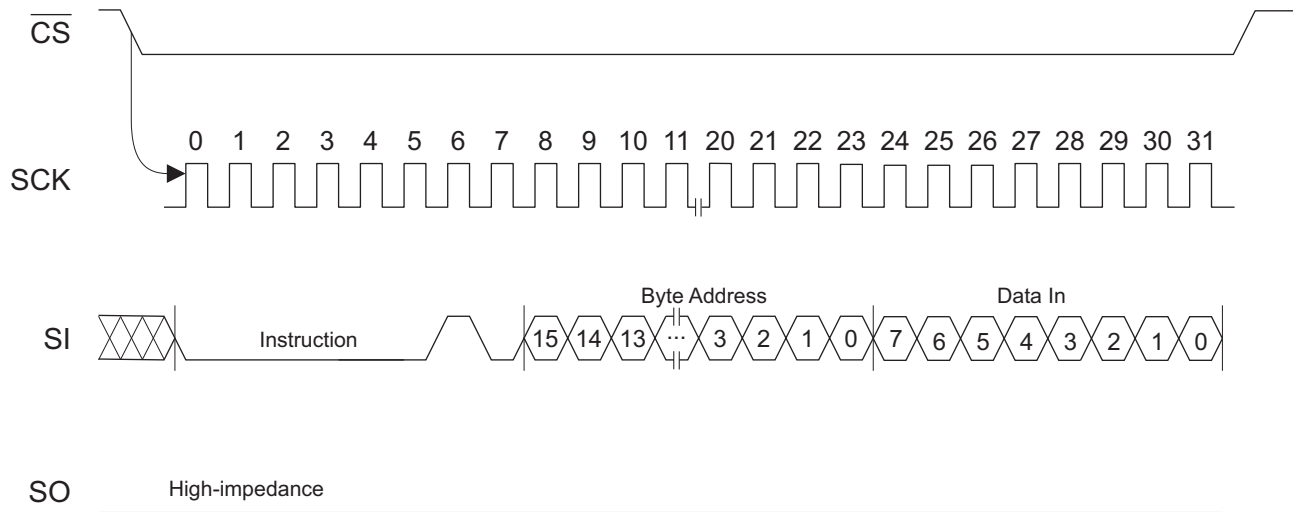
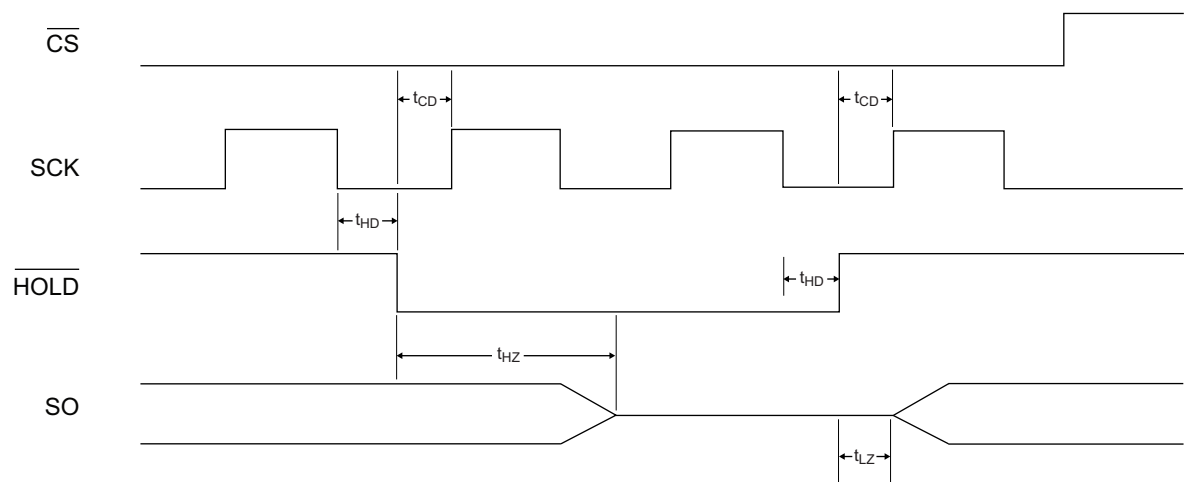
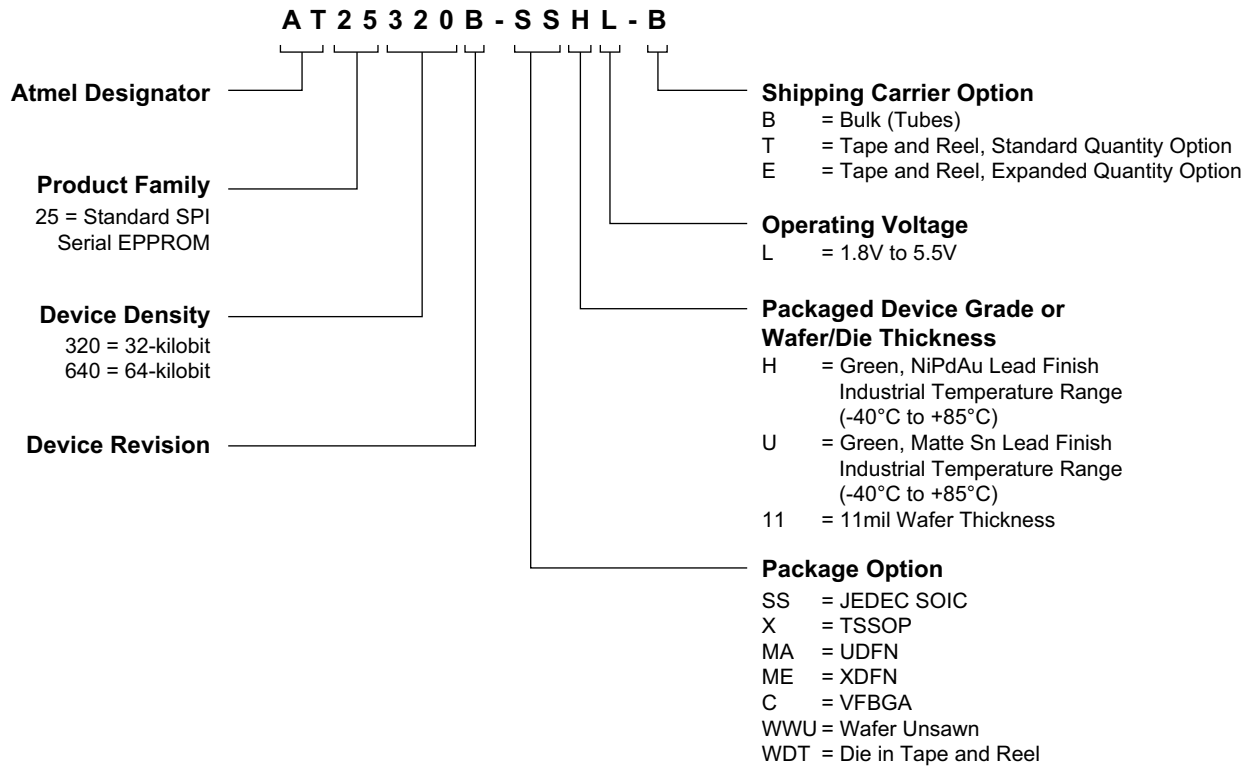

Figure 7-8. HOLD Timing





8. Ordering Code Detail

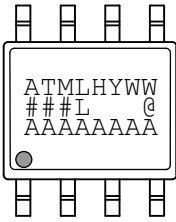
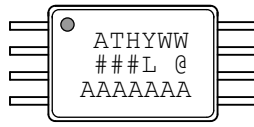
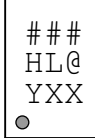
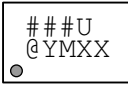

9. Part Markings

AT25320B and AT25640B: Package Marking Information

8-lead SOIC 	8-lead TSSOP 	8-lead UDFN 2.0 x 3.0 mm Body 
8-ball VFBGA 2.35 x 3.73 mm Body 	8-lead XDFN 1.8 x 2.2 mm Body 	

Note 1: ● designates pin 1

Note 2: Package drawings are not to scale

Catalog Number Truncation			
AT25320B		Truncation Code ###: 5BB	
AT25640B		Truncation Code ###: 5CB	
Date Codes			Voltages
Y = Year	M = Month	WW = Work Week of Assembly	L: 1.8V min
2: 2012 6: 2016	A: January	02: Week 2	
3: 2013 7: 2017	B: February	04: Week 4	
4: 2014 8: 2018	
5: 2015 9: 2019	L: December	52: Week 52	
Country of Assembly		Lot Number	Grade/Lead Finish Material
@ = Country of Assembly		AAA...A = Atmel Wafer Lot Number	U: Industrial/Matte Tin H: Industrial/NiPdAu
Trace Code			Atmel Truncation
XX = Trace Code (Atmel Lot Numbers Correspond to Code) Example: AA, AB.... YZ, ZZ			AT: Atmel ATM: Atmel ATML: Atmel

11/5/12

 Package Mark Contact: DL-CSO-Assy_eng@atmel.com	TITLE	DRAWING NO.	REV.
	25320-640BSM, AT25320B and AT25640B Package Marking Information	25320-640BSM	B

10. Ordering Information

Atmel Ordering Code	Lead Finish	Package	Delivery Information		Operation Range
			Form	Quantity	
AT25320B-SSHL-B	NiPdAu (Lead-free/Halogen-free)	8S1	Bulk (Tubes)	100 per Tube	Industrial Temperature (-40°C to 85°C)
AT25320B-SSHL-T			Tape and Reel	4,000 per Reel	
AT25320B-XHL-B		8X	Bulk (Tubes)	100 per Tube	
AT25320B-XHL-T			Tape and Reel	5,000 per Reel	
AT25320B-MAHL-T		8MA2	Tape and Reel	5,000 per Reel	
AT25320B-MAHL-E			Tape and Reel	15,000 per Reel	
AT25320B-MEHL-T		8ME1	Tape and Reel	5,000 per Reel	
AT25320B-CUL-T	SnAgCu (Lead-free/Halogen-free)	8U2-1	Tape and Reel	5,000 per Reel	
AT25320B-WWU11L ⁽¹⁾	N/A	Wafer Sale	Note 1		
AT25640B-SSHL-B	NiPdAu (Lead-free/Halogen-free)	8S1	Bulk (Tubes)	100 per Tube	Industrial Temperature (-40°C to 85°C)
AT25640B-SSHL-T			Tape and Reel	4,000 per Reel	
AT25640B-XHL-B		8X	Bulk (Tubes)	100 per Tube	
AT25640B-XHL-T			Tape and Reel	5,000 per Reel	
AT25640B-MAHL-T		8MA2	Tape and Reel	5,000 per Reel	
AT25640B-MAHL-E			Tape and Reel	15,000 per Reel	
AT25640B-MEHL-T		8ME1	Tape and Reel	5,000 per Reel	
AT25640B-CUL-T	SnAgCu (Lead-free/Halogen-free)	8U2-1	Tape and Reel	5,000 per Reel	
AT25640B-WWU11L ⁽¹⁾	N/A	Wafer Sale	Note 1		

Note: 1. Contact Atmel Sales for Wafer sales

Package Type	
8S1	8-lead, 0.15" wide, Plastic Gull Wing Small Outline (JEDEC SOIC)
8X	8-lead, 4.40mm body, Plastic Thin Shrink Small Outline Package (TSSOP)
8MA2	8-pad, 2.00mm x 3.00mm body, 0.50mm pitch, Ultra Thin, Dual No Lead (UDFN)
8ME1	8-pad, 1.80mm x 2.20mm body, Ultra Lead Frame Land Grid Array (XDFN)
8U2-1	8-ball, 2.35mm x 3.73mm body, 0.75mm pitch (VFBGA)

11. Packaging Information

11.1 8S1 — 8-lead JEDEC SOIC

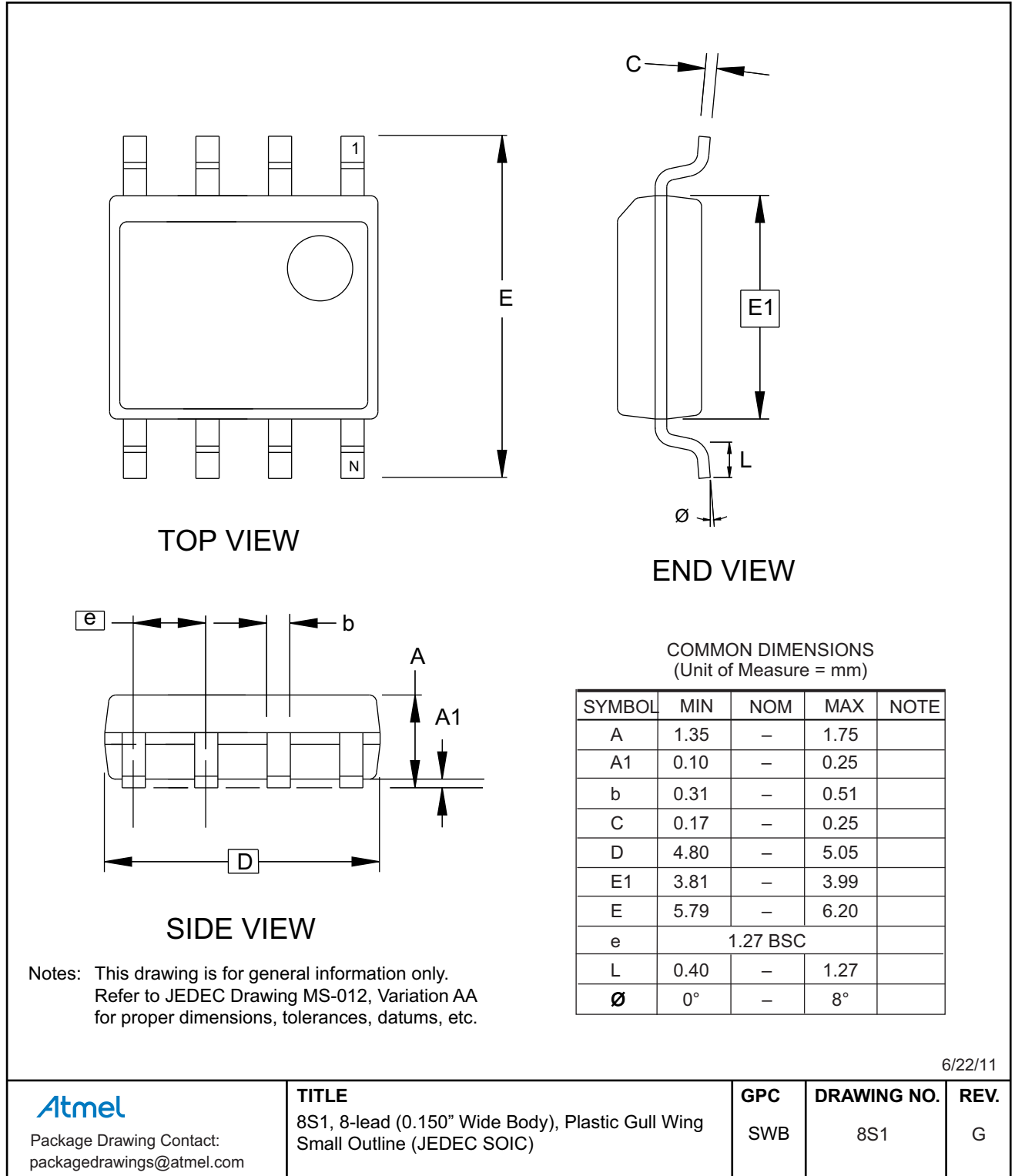

11.2 8X — 8-lead TSSOP



11.3 8MA2 — 8-pad UDFN

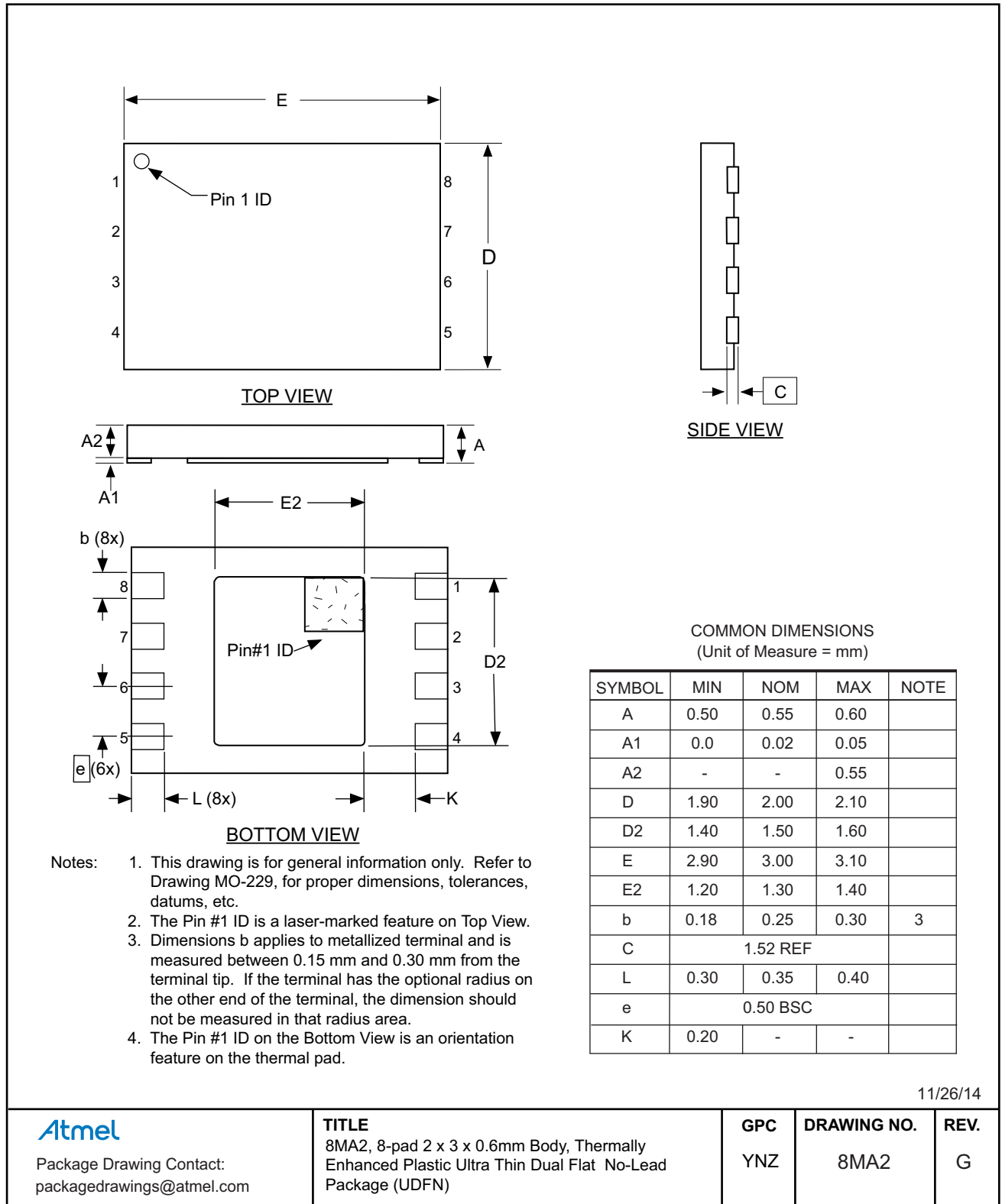

11/26/14

Atmel

Package Drawing Contact:
packagedrawings@atmel.com

TITLE

8MA2, 8-pad 2 x 3 x 0.6mm Body, Thermally Enhanced Plastic Ultra Thin Dual Flat No-Lead Package (UDFN)

GPC

YNZ

DRAWING NO.

8MA2

REV.

G

11.4 8ME1 — 8-pad XDFN

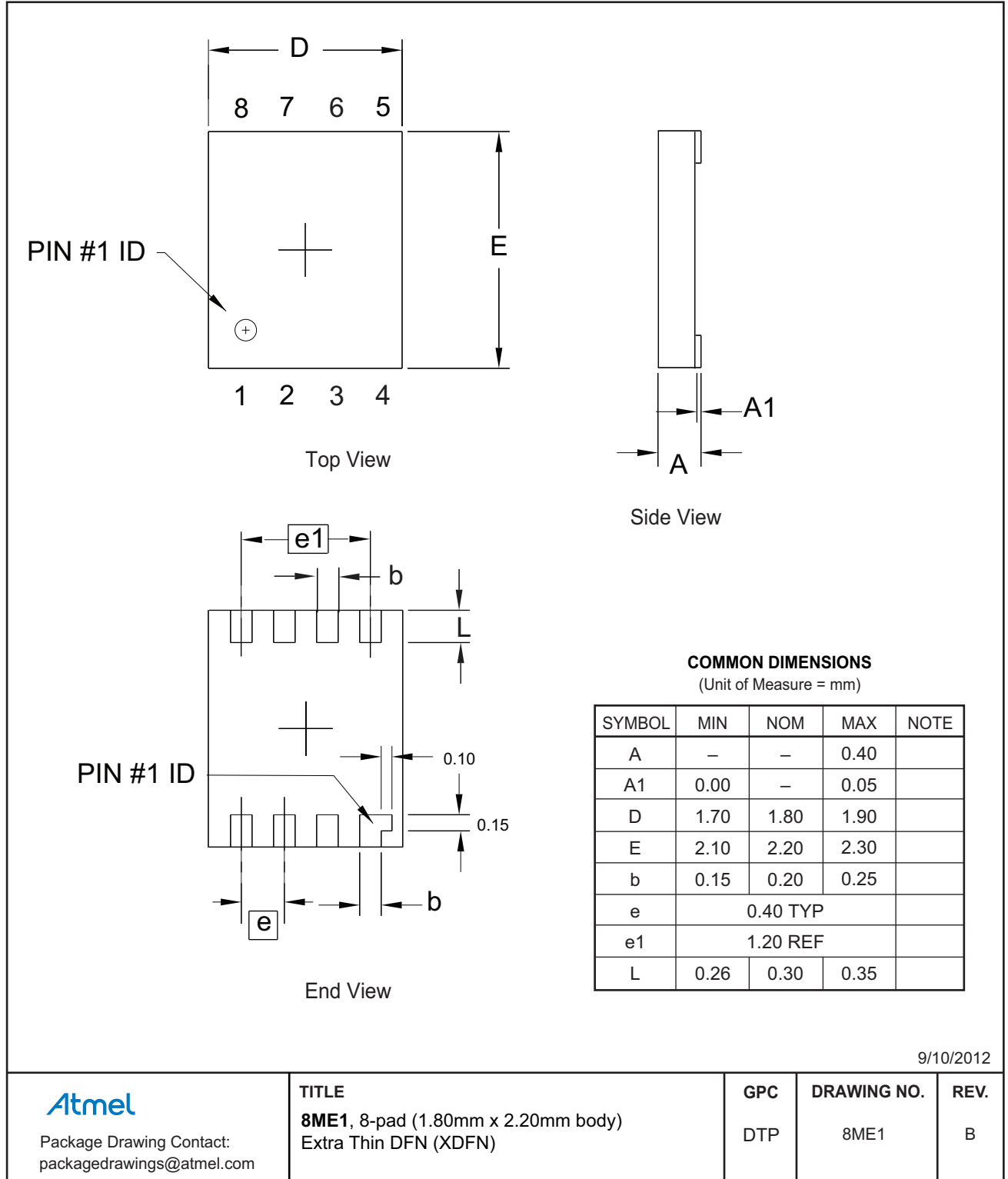

11.5 8U2-1 — 8-ball VFBGA

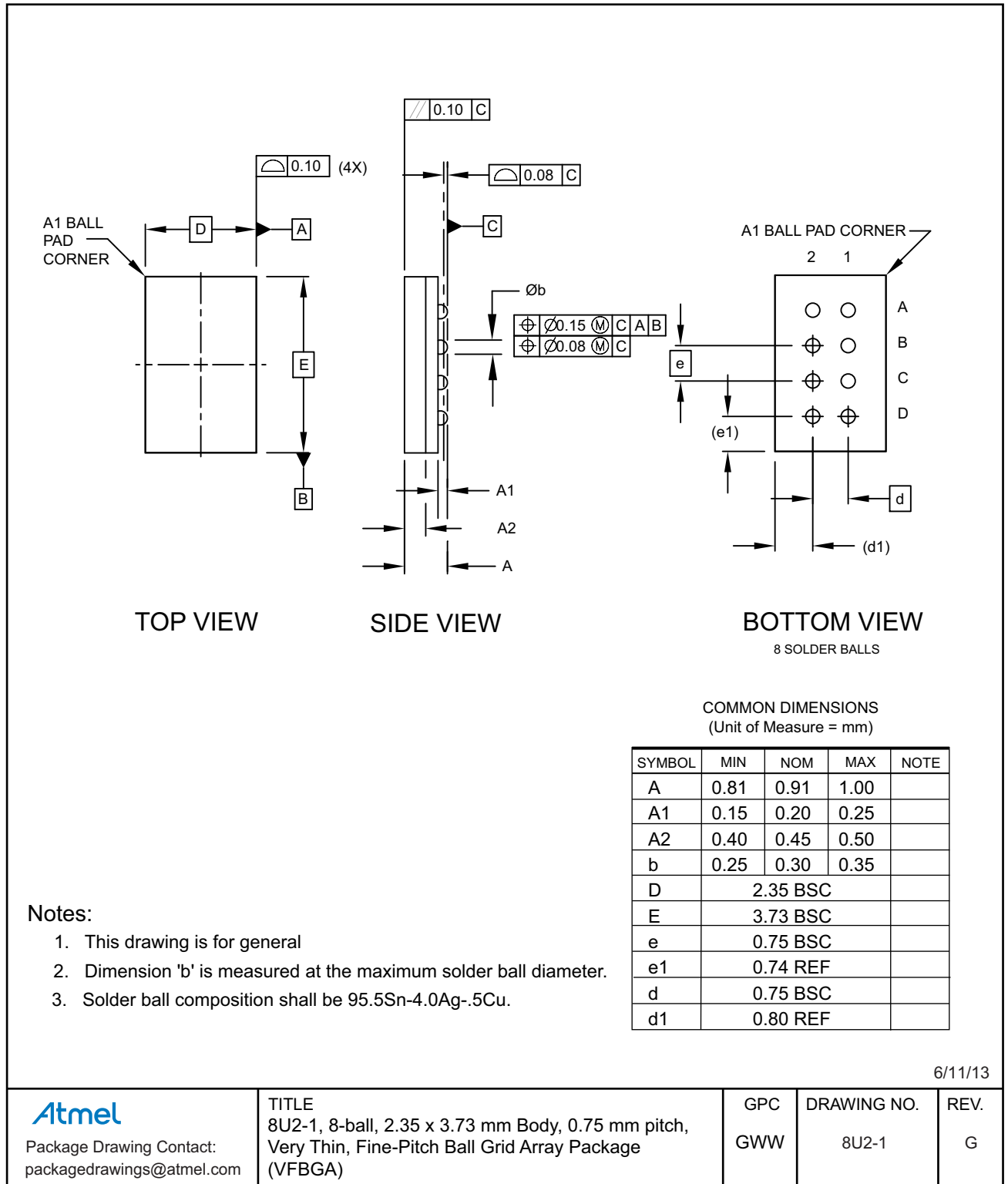

12. Revision History

Doc. Rev.	Date	Comments
8535H	01/2015	Add the UDFN Expanded Quantity Option. Update the 8X, 8MA2, and 8ME1 package outline drawings and the ordering information.
8535G	11/2012	Update part markings to single page part marking. Update package drawings. Replace 8A2 package with 8X package. Update template and Atmel logos.
8535F	06/2010	Update 8A2 and 8S1 package drawings. Remove Preliminary.
8535E	04/2010	Update Ordering Code Detail, Ordering Information, template.
8535D	08/2009	Change Catalog Numbering. Add new Part Marking Information.
8535C	05/2009	Add Part Marking information; changed to Preliminary status.
8535B	07/2008	Modify 'Endurance' parameter on page 6.
8535A	04/2008	Initial document release.



Atmel®, Atmel logo and combinations thereof, Enabling Unlimited Possibilities®, and others are registered trademarks or trademarks of Atmel Corporation in U.S. and other countries. Other terms and product names may be trademarks of others.

DISCLAIMER: The information in this document is provided in connection with Atmel products. No license, express or implied, by estoppel or otherwise, to any intellectual property right is granted by this document or in connection with the sale of Atmel products. EXCEPT AS SET FORTH IN THE ATMEL TERMS AND CONDITIONS OF SALES LOCATED ON THE ATMEL WEBSITE, ATMEL ASSUMES NO LIABILITY WHATSOEVER AND DISCLAIMS ANY EXPRESS, IMPLIED OR STATUTORY WARRANTY RELATING TO ITS PRODUCTS INCLUDING, BUT NOT LIMITED TO, THE IMPLIED WARRANTY OF MERCHANTABILITY, FITNESS FOR A PARTICULAR PURPOSE, OR NON-INFRINGEMENT. IN NO EVENT SHALL ATMEL BE LIABLE FOR ANY DIRECT, INDIRECT, CONSEQUENTIAL, PUNITIVE, SPECIAL OR INCIDENTAL DAMAGES (INCLUDING, WITHOUT LIMITATION, DAMAGES FOR LOSS AND PROFITS, BUSINESS INTERRUPTION, OR LOSS OF INFORMATION) ARISING OUT OF THE USE OR INABILITY TO USE THIS DOCUMENT, EVEN IF ATMEL HAS BEEN ADVISED OF THE POSSIBILITY OF SUCH DAMAGES. Atmel makes no representations or warranties with respect to the accuracy or completeness of the contents of this document and reserves the right to make changes to specifications and products descriptions at any time without notice. Atmel does not make any commitment to update the information contained herein. Unless specifically provided otherwise, Atmel products are not suitable for, and shall not be used in, automotive applications. Atmel products are not intended, authorized, or warranted for use as components in applications intended to support or sustain life.

SAFETY-CRITICAL, MILITARY, AND AUTOMOTIVE APPLICATIONS DISCLAIMER: Atmel products are not designed for and will not be used in connection with any applications where the failure of such products would reasonably be expected to result in significant personal injury or death ("Safety-Critical Applications") without an Atmel officer's specific written consent. Safety-Critical Applications include, without limitation, life support devices and systems, equipment or systems for the operation of nuclear facilities and weapons systems. Atmel products are not designed nor intended for use in military or aerospace applications or environments unless specifically designated by Atmel as military-grade. Atmel products are not designed nor intended for use in automotive applications unless specifically designated by Atmel as automotive-grade.



Компания «ЭлектроПласт» предлагает заключение долгосрочных отношений при поставках импортных электронных компонентов на взаимовыгодных условиях!

Наши преимущества:

- Оперативные поставки широкого спектра электронных компонентов отечественного и импортного производства напрямую от производителей и с крупнейших мировых складов;
- Поставка более 17-ти миллионов наименований электронных компонентов;
- Поставка сложных, дефицитных, либо снятых с производства позиций;
- Оперативные сроки поставки под заказ (от 5 рабочих дней);
- Экспресс доставка в любую точку России;
- Техническая поддержка проекта, помощь в подборе аналогов, поставка прототипов;
- Система менеджмента качества сертифицирована по Международному стандарту ISO 9001;
- Лицензия ФСБ на осуществление работ с использованием сведений, составляющих государственную тайну;
- Поставка специализированных компонентов (Xilinx, Altera, Analog Devices, Intersil, Interpoint, Microsemi, Aeroflex, Peregrine, Syfer, Eurofarad, Texas Instrument, Miteq, Cobham, E2V, MA-COM, Hittite, Mini-Circuits, General Dynamics и др.);

Помимо этого, одним из направлений компании «ЭлектроПласт» является направление «Источники питания». Мы предлагаем Вам помощь Конструкторского отдела:

- Подбор оптимального решения, техническое обоснование при выборе компонента;
- Подбор аналогов;
- Консультации по применению компонента;
- Поставка образцов и прототипов;
- Техническая поддержка проекта;
- Защита от снятия компонента с производства.



Как с нами связаться

Телефон: 8 (812) 309 58 32 (многоканальный)

Факс: 8 (812) 320-02-42

Электронная почта: org@eplast1.ru

Адрес: 198099, г. Санкт-Петербург, ул. Калинина, дом 2, корпус 4, литера А.