



MICROCHIP

**MCP1662
LED Driver
Evaluation Board
User's Guide**

Note the following details of the code protection feature on Microchip devices:

- Microchip products meet the specification contained in their particular Microchip Data Sheet.
- Microchip believes that its family of products is one of the most secure families of its kind on the market today, when used in the intended manner and under normal conditions.
- There are dishonest and possibly illegal methods used to breach the code protection feature. All of these methods, to our knowledge, require using the Microchip products in a manner outside the operating specifications contained in Microchip's Data Sheets. Most likely, the person doing so is engaged in theft of intellectual property.
- Microchip is willing to work with the customer who is concerned about the integrity of their code.
- Neither Microchip nor any other semiconductor manufacturer can guarantee the security of their code. Code protection does not mean that we are guaranteeing the product as "unbreakable."

Code protection is constantly evolving. We at Microchip are committed to continuously improving the code protection features of our products. Attempts to break Microchip's code protection feature may be a violation of the Digital Millennium Copyright Act. If such acts allow unauthorized access to your software or other copyrighted work, you may have a right to sue for relief under that Act.

Information contained in this publication regarding device applications and the like is provided only for your convenience and may be superseded by updates. It is your responsibility to ensure that your application meets with your specifications. MICROCHIP MAKES NO REPRESENTATIONS OR WARRANTIES OF ANY KIND WHETHER EXPRESS OR IMPLIED, WRITTEN OR ORAL, STATUTORY OR OTHERWISE, RELATED TO THE INFORMATION, INCLUDING BUT NOT LIMITED TO ITS CONDITION, QUALITY, PERFORMANCE, MERCHANTABILITY OR FITNESS FOR PURPOSE. Microchip disclaims all liability arising from this information and its use. Use of Microchip devices in life support and/or safety applications is entirely at the buyer's risk, and the buyer agrees to defend, indemnify and hold harmless Microchip from any and all damages, claims, suits, or expenses resulting from such use. No licenses are conveyed, implicitly or otherwise, under any Microchip intellectual property rights.

Trademarks

The Microchip name and logo, the Microchip logo, dsPIC, FlashFlex, flexPWR, JukeBlox, KEELOQ, KEELOQ logo, Kleer, LANCheck, MediaLB, MOST, MOST logo, MPLAB, OptoLyzer, PIC, PICSTART, PIC³² logo, RightTouch, SpyNIC, SST, SST Logo, SuperFlash and UNI/O are registered trademarks of Microchip Technology Incorporated in the U.S.A. and other countries.

The Embedded Control Solutions Company and mTouch are registered trademarks of Microchip Technology Incorporated in the U.S.A.

Analog-for-the-Digital Age, BodyCom, chipKIT, chipKIT logo, CodeGuard, dsPICDEM, dsPICDEM.net, ECAN, In-Circuit Serial Programming, ICSP, Inter-Chip Connectivity, KleerNet, KleerNet logo, MiWi, MPASM, MPF, MPLAB Certified logo, MPLIB, MPLINK, MultiTRAK, NetDetach, Omniscient Code Generation, PICDEM, PICDEM.net, PICkit, PICtail, RightTouch logo, REAL ICE, SQI, Serial Quad I/O, Total Endurance, TSHARC, USBCheck, VariSense, ViewSpan, WiperLock, Wireless DNA, and ZENA are trademarks of Microchip Technology Incorporated in the U.S.A. and other countries.

SQTP is a service mark of Microchip Technology Incorporated in the U.S.A.

Silicon Storage Technology is a registered trademark of Microchip Technology Inc. in other countries.

GestIC is a registered trademarks of Microchip Technology Germany II GmbH & Co. KG, a subsidiary of Microchip Technology Inc., in other countries.

All other trademarks mentioned herein are property of their respective companies.

© 2014, Microchip Technology Incorporated, Printed in the U.S.A., All Rights Reserved.

ISBN: 978-1-63276-351-8

**QUALITY MANAGEMENT SYSTEM
CERTIFIED BY DNV
= ISO/TS 16949 =**

Microchip received ISO/TS-16949:2009 certification for its worldwide headquarters, design and wafer fabrication facilities in Chandler and Tempe, Arizona; Gresham, Oregon and design centers in California and India. The Company's quality system processes and procedures are for its PIC[®] MCUs and dsPIC[®] DSCs, KEELOQ[®] code hopping devices, Serial EEPROMs, microperipherals, nonvolatile memory and analog products. In addition, Microchip's quality system for the design and manufacture of development systems is ISO 9001:2000 certified.

Object of Declaration: MCP1662 LED Driver Evaluation Board

EU Declaration of Conformity

This declaration of conformity is issued by the manufacturer.

The development/evaluation tool is designed to be used for research and development in a laboratory environment. This development/evaluation tool is not a Finished Appliance, nor is it intended for incorporation into Finished Appliances that are made commercially available as single functional units to end users under EU EMC Directive 2004/108/EC and as supported by the European Commission's Guide for the EMC Directive 2004/108/EC (8th February 2010).

This development/evaluation tool complies with EU RoHS2 Directive 2011/65/EU.

For information regarding the exclusive, limited warranties applicable to Microchip products, please see Microchip's standard terms and conditions of sale, which are printed on our sales documentation and available at www.microchip.com.

Signed for and on behalf of Microchip Technology Inc. at Chandler, Arizona, USA

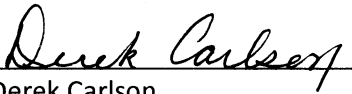

Derek Carlson

VP Development Tools

16-July-2013

Date

MCP1662 LED Driver Evaluation Board User's Guide

NOTES:

Table of Contents

Preface	7
Introduction.....	7
Document Layout	7
Conventions Used in this Guide	8
Recommended Reading.....	9
The Microchip Web Site	9
Customer Support	9
Document Revision History	9
 Chapter 1. Product Overview	
1.1 Introduction	11
1.2 MCP1662 Short Overview	11
1.3 What is the MCP1662 LED Driver Evaluation Board?	12
1.4 What the MCP1662 LED Driver Evaluation Board Kit Contains	12
 Chapter 2. Installation and Operation	
2.1 Introduction	13
2.2 Features	13
2.3 Getting Started	14
 Appendix A. Schematic and Layouts	
A.1 Introduction	17
A.2 Board – Schematic	18
A.3 Board – Top Silk	19
A.4 Board – Top Silk And Copper	19
A.5 Board – Bottom Copper	19
 Appendix B. Bill of Materials (BOM)	
Worldwide Sales and Service	22

MCP1662 LED Driver Evaluation Board User's Guide

Preface

NOTICE TO CUSTOMERS

All documentation becomes dated, and this manual is no exception. Microchip tools and documentation are constantly evolving to meet customer needs, so some actual dialogs and/or tool descriptions may differ from those in this document. Please refer to our web site (www.microchip.com) to obtain the latest documentation available.

Documents are identified with a “DS” number. This number is located on the bottom of each page, in front of the page number. The numbering convention for the DS number is “DSXXXXXXA”, where “XXXXXX” is the document number and “A” is the revision level of the document.

For the most up-to-date information on development tools, see the MPLAB® IDE online help. Select the Help menu, and then Topics to open a list of available online help files.

INTRODUCTION

This chapter contains general information that will be useful to know before using the MCP1662 LED Driver Evaluation Board. Items discussed in this chapter include:

- Document Layout
- Conventions Used in this Guide
- Recommended Reading
- The Microchip Web Site
- Customer Support
- Document Revision History

DOCUMENT LAYOUT

This document describes how to use the MCP1662 LED Driver Evaluation Board as a development tool. The manual layout is as follows:

- **Chapter 1. “Product Overview”** – Important information about the MCP1662 LED Driver Evaluation Board.
- **Chapter 2. “Installation and Operation”** – Includes instructions on how to get started with this user’s guide and a description of the user’s guide.
- **Appendix A. “Schematic and Layouts”** – Shows the schematic and layout diagrams for the MCP1662 LED Driver Evaluation Board.
- **Appendix B. “Bill of Materials (BOM)”** – Lists the parts used to build the MCP1662 LED Driver Evaluation Board.

MCP1662 LED Driver Evaluation Board User's Guide

CONVENTIONS USED IN THIS GUIDE

This manual uses the following documentation conventions:

DOCUMENTATION CONVENTIONS

Description	Represents	Examples
Arial font:		
Italic characters	Referenced books	<i>MPLAB[®] IDE User's Guide</i>
	Emphasized text	...is the <i>only</i> compiler...
Initial caps	A window	the Output window
	A dialog	the Settings dialog
	A menu selection	select Enable Programmer
Quotes	A field name in a window or dialog	"Save project before build"
Underlined, italic text with right angle bracket	A menu path	<u><i>File>Save</i></u>
Bold characters	A dialog button	Click OK
	A tab	Click the Power tab
N'Rnnnn	A number in verilog format, where N is the total number of digits, R is the radix and n is a digit.	4'b0010, 2'hF1
Text in angle brackets < >	A key on the keyboard	Press <Enter>, <F1>
Courier New font:		
Plain Courier New	Sample source code	#define START
	Filenames	autoexec.bat
	File paths	c:\mcc18\h
	Keywords	_asm, _endasm, static
	Command-line options	-Opa+, -Opa-
	Bit values	0, 1
	Constants	0xFF, 'A'
Italic Courier New	A variable argument	<i>file.o</i> , where <i>file</i> can be any valid filename
Square brackets []	Optional arguments	mcc18 [options] <i>file</i> [options]
Curly brackets and pipe character: { }	Choice of mutually exclusive arguments; an OR selection	errorlevel {0 1}
Ellipses...	Replaces repeated text	var_name [, var_name...]
	Represents code supplied by user	void main (void) { ... }

RECOMMENDED READING

This user's guide describes how to use MCP1662 LED Driver Evaluation Board. Other useful documents are listed below. The following Microchip documents are available and recommended as supplemental reference resources.

- **MCP1662 Data Sheet - “High-Voltage Step-Up LED Driver with UVLO and Open Load Protection” (DS20005316)**
- **MCP1661 Data Sheet - “High-Voltage Integrated Switch PWM Boost Regulator with UVLO” (DS20005315)**

THE MICROCHIP WEB SITE

Microchip provides online support via our web site at www.microchip.com. This web site is used as a means to make files and information easily available to customers. Accessible by using your favorite Internet browser, the web site contains the following information:

- **Product Support** – Data sheets and errata, application notes and sample programs, design resources, user's guides and hardware support documents, latest software releases and archived software
- **General Technical Support** – Frequently Asked Questions (FAQs), technical support requests, online discussion groups, Microchip consultant program member listing
- **Business of Microchip** – Product selector and ordering guides, latest Microchip press releases, listing of seminars and events, listings of Microchip sales offices, distributors and factory representatives

CUSTOMER SUPPORT

Users of Microchip products can receive assistance through several channels:

- Distributor or Representative
- Local Sales Office
- Field Application Engineer (FAE)
- Technical Support

Customers should contact their distributor, representative or field application engineer (FAE) for support. Local sales offices are also available to help customers. A listing of sales offices and locations is included in the back of this document.

Technical support is available through the web site at:
<http://www.microchip.com/support>.

DOCUMENT REVISION HISTORY

Revision A (June 2014)

- Initial Release of this Document.

MCP1662 LED Driver Evaluation Board User's Guide

NOTES:

Chapter 1. Product Overview

1.1 INTRODUCTION

This chapter provides an overview of the MCP1662 and covers the following topics:

- MCP1662 Short Overview
- What is the MCP1662 LED Driver Evaluation Board?
- What the MCP1662 LED Driver Evaluation Board Kit Contains

1.2 MCP1662 SHORT OVERVIEW

The MCP1662 is a compact, battery operated, fixed frequency, step-up DC/DC converter optimized as an LED constant current generator. This product provides an easy-to-use power supply solution for LEDs, with a minimum number of external components for applications powered by two-cell or three cell alkaline, NiCd or NiMH batteries, one-cell Li-Ion or Li-Polymer batteries.

The MCP1662 is a boost device with PWM-only functionality that operates at a fixed 500 kHz switching frequency. The device has an operating input voltage range from 2.4V to 5.5V (with a typical undervoltage of 2.3V to start and 1.85V to stop). Compared to its counterpart, the MCP1661, the reference voltage is only 300 mV in order to minimize the losses on the sense resistor and increase the overall efficiency of the application.

The LED can be turned on and off with a variable duty cycle applied to the EN pin for applications that require current dimming (variable lighting). Compared to its counterpart, the MCP1661, which is designed to be a voltage source, the start-up time for the MCP1662 has been decreased in order to obtain higher dimming frequencies.

The MCP1662 can supply up to 100 mA of current for a string of four white LEDs (LED forward voltage of 3.2V) from a 3V or higher input voltage source. More detailed information regarding the current capabilities of the MCP1662 are available in the data sheet.

In order to obtain a compact solution, the device is available in a small 5-Lead SOT-23 and an 8-Lead 2X3 TDFN package.

MCP1662 LED Driver Evaluation Board User's Guide

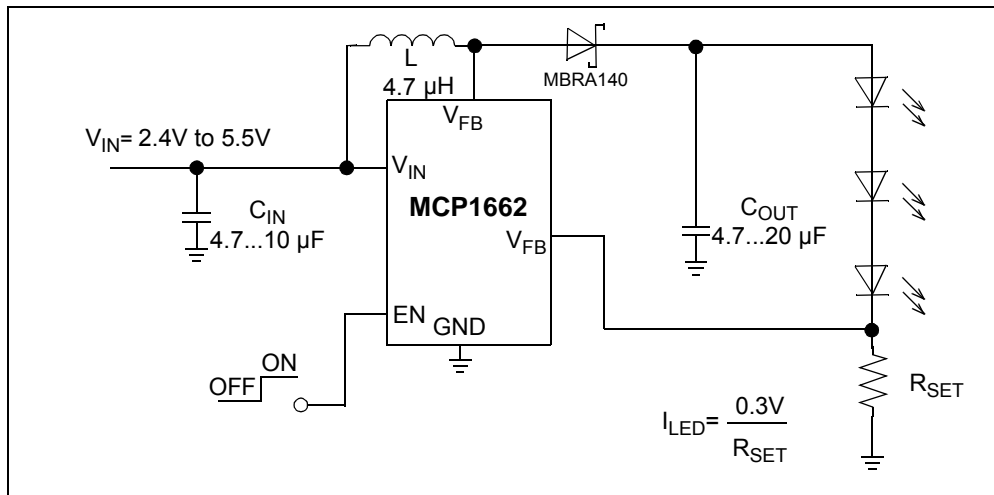

FIGURE 1-1: Typical MCP1662 LED Driver Boost Converter Application.

1.3 WHAT IS THE MCP1662 LED DRIVER EVALUATION BOARD?

The MCP1662 LED Driver Evaluation Board is used to evaluate and demonstrate Microchip Technology's MCP1662 product. This board demonstrates the MCP1662 in a boost-converter application supplied by two AA batteries, or from an external voltage source, which drives a string of LEDs with three selectable currents. The MCP1662 LED Driver Evaluation Board was developed to help engineers reduce the product design cycle time.

Three output currents can be selected: 30 mA, 60 mA and 90 mA. The output current can be changed with a dual switch that changes the external LED current sense equivalent resistance (R_{SET}).

An enable switch is used to enable and disable the converter. When enabled, the MCP1662 will regulate the output current; when disabled, the current consumed from the battery by the device is typically less than 20 nA.

1.4 WHAT THE MCP1662 LED DRIVER EVALUATION BOARD KIT CONTAINS

This MCP1662 LED Driver Evaluation Board kit includes:

- MCP1662 LED Driver Evaluation Board (ADM00555)
- Important Information Sheet

Chapter 2. Installation and Operation

2.1 INTRODUCTION

The MCP1662 has been developed for applications that require driving a string of LEDs from a low-voltage source. Using a peak current mode control the MCP1662 offers good line and load step responses over a wide output range (up to 32V total output voltage or 10 white LEDs). The integration of compensation and protection circuitry is an important feature that minimizes the required number of additional components.

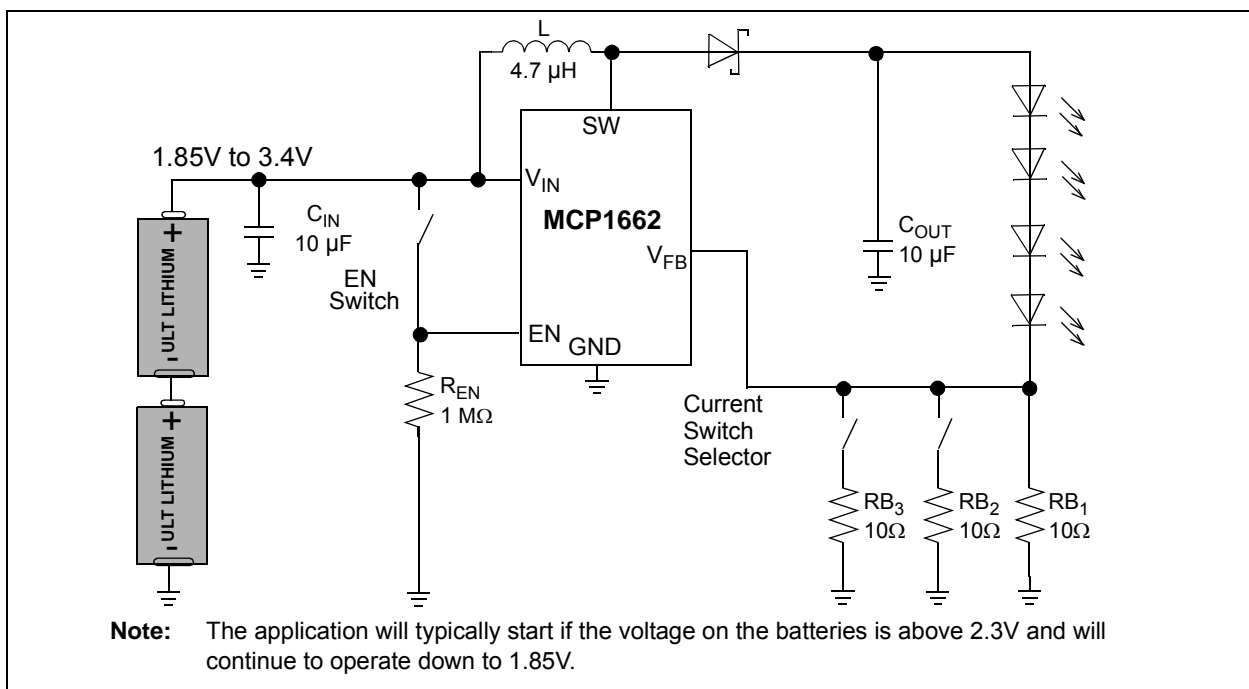

FIGURE 2-1: MCP1662 Boost 30, 60, 90 mA Constant Current Application.

2.2 FEATURES

The MCP1662 LED Driver Evaluation Board has the following features:

- It can be powered by two-cell Alkaline, NiCd, NiMH or Lithium AA cell batteries
- Input Voltage range (V_{IN}): 2.4V to 5.5V, with $V_{IN} < V_{OUT}$
- Undervoltage Lockout: 2.3V to Start; 1.85V to Stop
- Adjustable Output Current: 30 mA, 60 mA or 90 mA, selected using a dual switch on-board
- PWM Switching Frequency: 500 kHz
- Enable converter using switch on board
- 1.3A Peak Input Current Limit
- Overtemperature Protection (if the die temperature exceeds +150°C, with 15°C hysteresis)
- Open Load Protection in case of: LED fail or FB disconnected/fault

MCP1662 LED Driver Evaluation Board User's Guide

2.3 GETTING STARTED

The MCP1662 LED Driver Evaluation Board is fully assembled and tested to evaluate and demonstrate the MCP1662 product. This board requires the use of external lab supplies or two AA batteries.

2.3.1 Power Input and Output Connection

2.3.1.1 POWERING THE MCP1662 LED DRIVER EVALUATION BOARD

Soldered test points are available for input voltage connections. The maximum input voltage should not exceed 5.5V. The output current will not remain in regulation for input voltages that are greater than or equal to the forward voltage of the LEDs.

The MCP1662 LED Driver Evaluation Board was designed to help the engineer validate the MCP1662 device. The package selected for the MCP1662 LED Driver Evaluation Board is 5-Lead SOT-23.

SW1 is the enable switch, which gives the state of the converter, On or Off. A soldered test point is also available for the EN pin, that can be used for PWM dimming. The second switch is used to modify the value of the sense resistor, in order to modify the LED current and achieve analog dimming.

2.3.1.2 BOARD POWER UP PROCEDURE:

1. Connect input supply as shown in [Figure 2-2](#) or insert two AA batteries in the battery holder on the bottom side of the board. Respect the polarity of the batteries.
2. Using the EN switch, the state of the converter is changed from On to Off.
3. Change the value of the output current using the Current Switch Selector. There are three available currents: 30 mA, 60 mA and 90 mA. When changing the positions of the Current Switch Selector, the value of the sense resistor is modified and the brightness of the LEDs change.

Additional test points are available to visualize different signals (SW, output current, FB) or to modify the output current by dimming, using the EN pin.

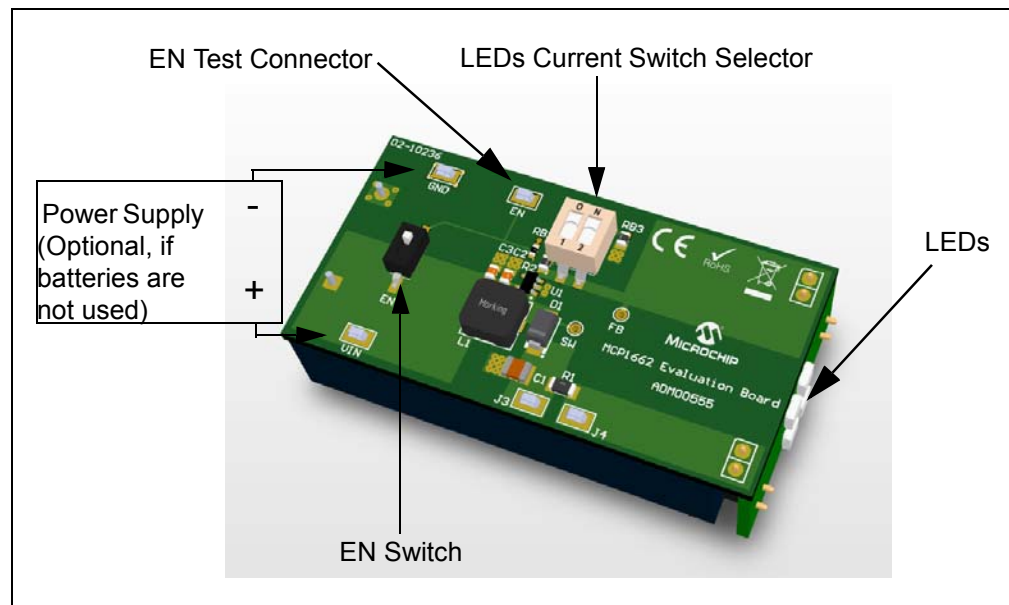

FIGURE 2-2: MCP1662 LED Driver Evaluation Board Setup.

2.3.1.3 ADJUSTABLE LED CURRENT BY RECALCULATING THE SENSE RESISTOR (ANALOG DIMMING)

The Sense Resistor (R_{SET}) is used to modify the value of the output current. The value for the resistor can be calculated using [Equation 2-1](#):

EQUATION 2-1:

$$R_{SET} = \left[\frac{V_{FB}}{I_{LED}} \right]$$

Where: $V_{FB} = 0.300V$

Note: If the Sense Resistor is recalculated, the Current Switch Selector will not have the same functionality, as the Sense Resistor will add a resistor in parallel with the calculated component and the value of the current will be different than the one specified in the User Guide. The Sense Resistor will be used in place of the RB_x resistors.

2.3.1.4 ADJUSTABLE LED CURRENT BY USING THE EN PIN (PWM DIMMING)

The MCP1662 allows PWM dimming by turning the LED on and off with a variable duty cycle PWM signal applied to the EN pin. The maximum frequency for dimming is limited by the start-up and the load. By varying the duty cycle of the PWM signal applied on the EN input, the LED current changes linearly. An example of PWM dimming can be observed in [Figure 2-3](#).

By removing the 0 Ohms R1 Resistor, the soldered connectors (J3 and J4) can be used to either insert a multimeter to measure the LED current or to create a loop through which, with the help of an oscilloscope current probe, the current through the LED can be visualized.

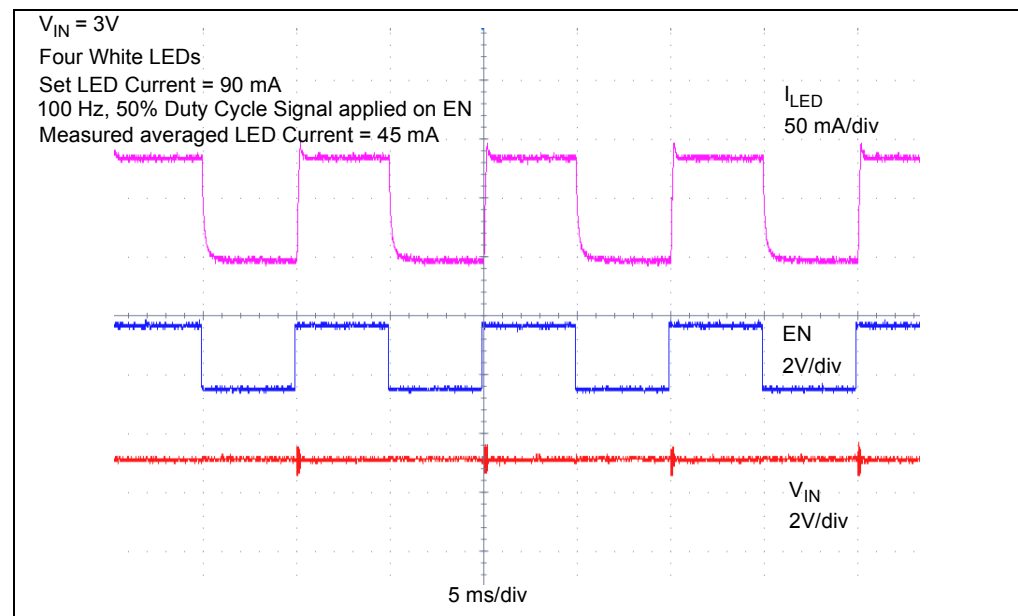

FIGURE 2-3: PWM Dimming with MCP1662.

MCP1662 LED Driver Evaluation Board User's Guide

NOTES:



MCP1662 LED DRIVER EVALUATION BOARD USER'S GUIDE

Appendix A. Schematic and Layouts

A.1 INTRODUCTION

This appendix contains the following schematics and layouts for the MCP1662 LED Driver Evaluation Board:

- Board – Schematic
- Board – Top Silk
- Board – Top Silk And Copper
- Board – Bottom Copper

A.2 BOARD - SCHEMATIC

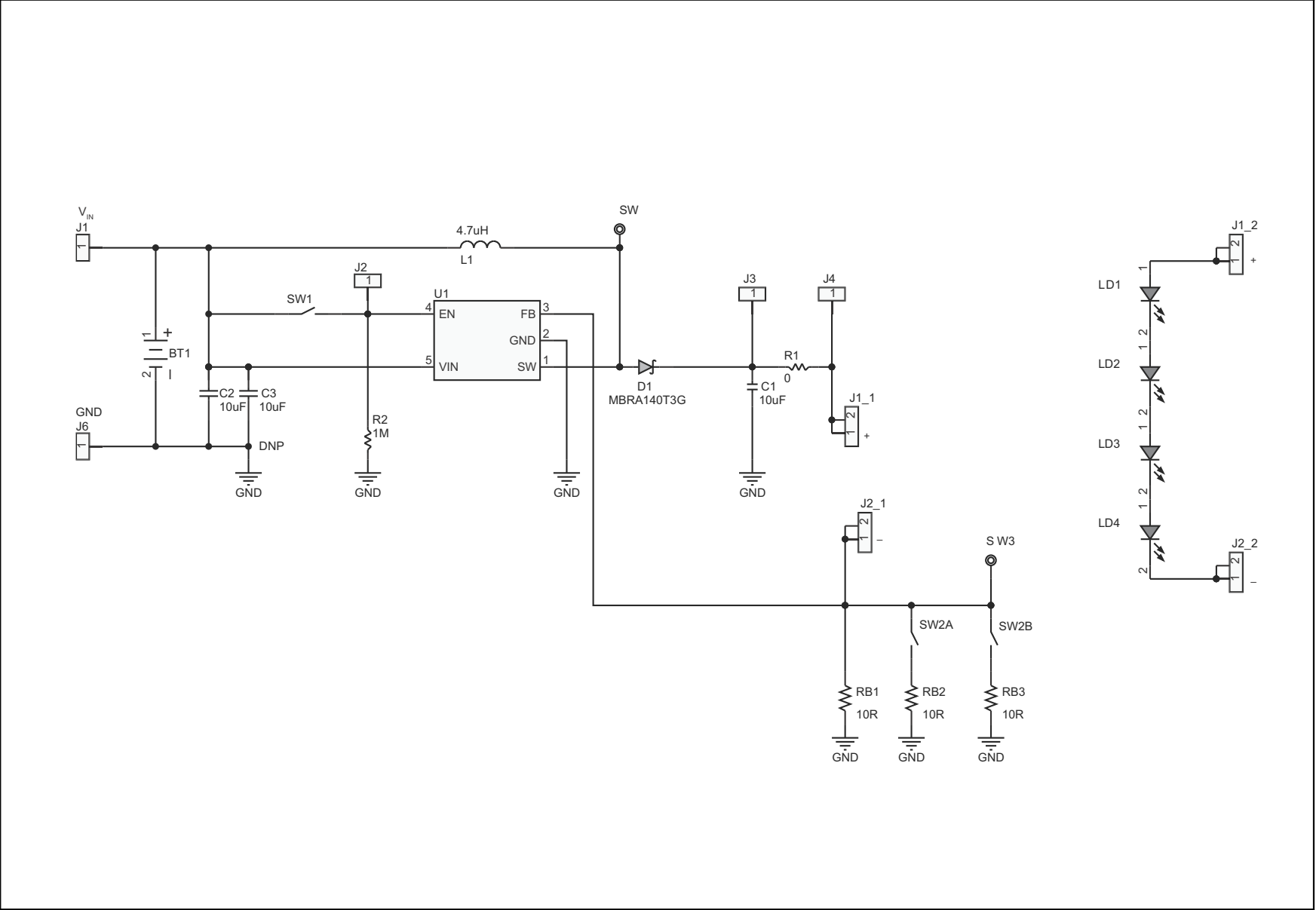

A.3 BOARD – TOP SILK

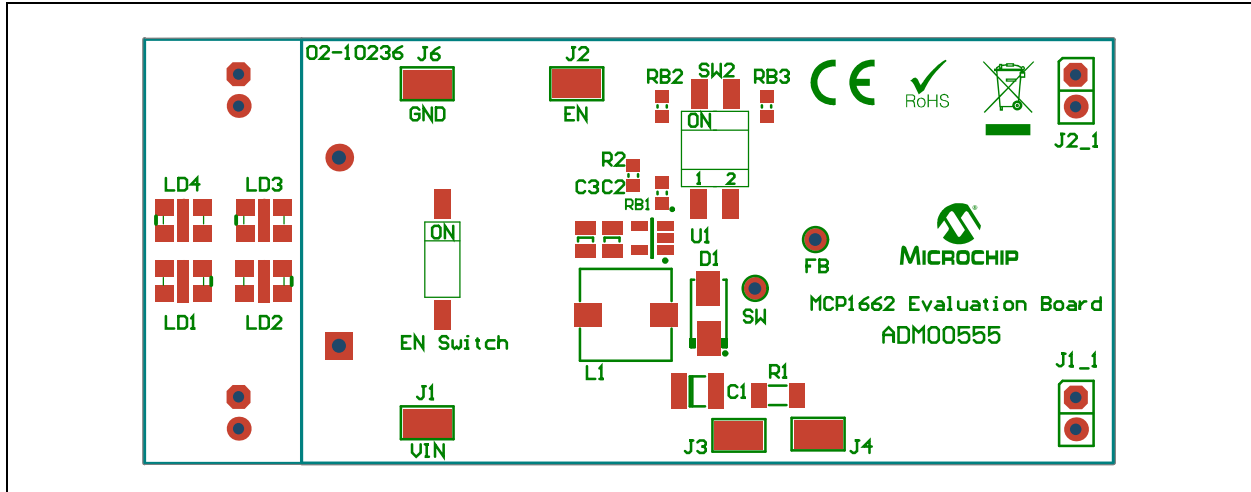

A.4 BOARD – TOP SILK AND COPPER

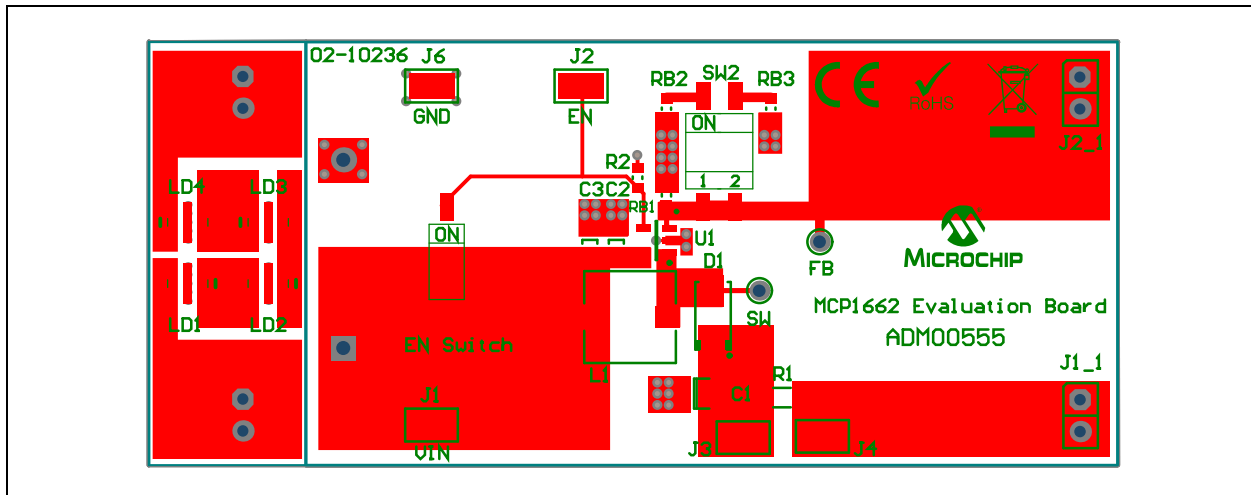

A.5 BOARD – BOTTOM COPPER

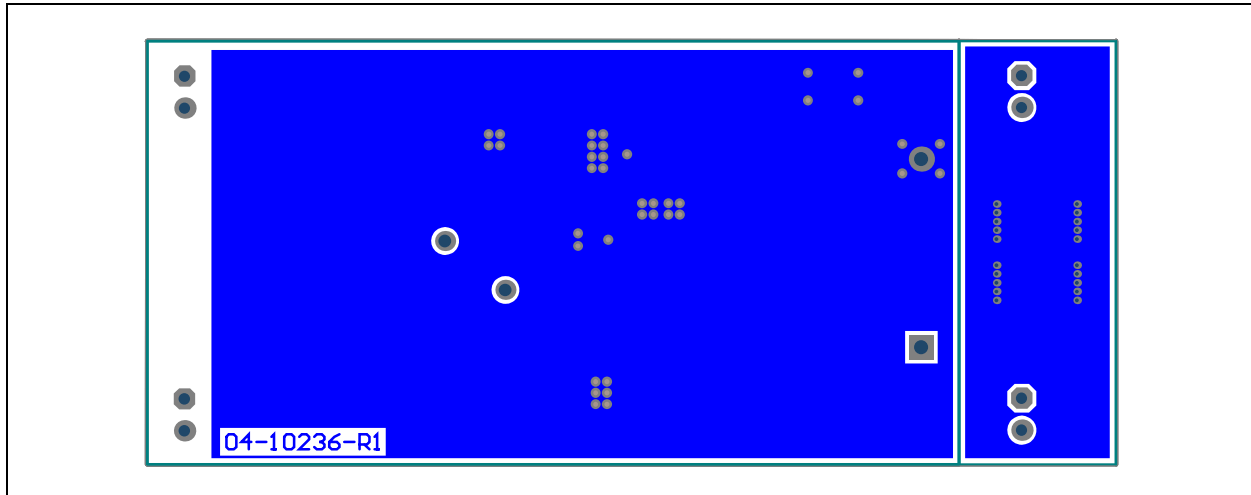

MCP1662 LED Driver Evaluation Board User's Guide

NOTES:

Appendix B. Bill of Materials (BOM)

TABLE B-1: BILL OF MATERIALS (BOM)

Qty.	Reference	Description	Manufacturer	Part Number
1	BT1	Battery Holder	Keystone Electronics Corp.	2462
1	C1	Cap. Ceramic 10 μ F 50V X7S 1210	TDK Corporation	C3225X7S1H106M
1	C2	Cap. Ceramic 10 μ F 10V 10% X7R SMD 0805	Murata Electronics®	GRM21BR71A106KE51L
1	C3	Cap. Ceramic 10 μ F 10V 10% X7R SMD 0805 - DO NOT POPULATE	Murata Electronics®	GRM21BR71A106KE51L
1	D1	Diode Schottky 40V 1A SMA	ON Semiconductor®	MBRA140T3G
2	J1_2, J2_2	Header 2.54 mm, Pin, THT, R/A, 2-Way	Würth Elektronik	61300211021
5	J1, J2, J3, J4, J6	Conn. TP Loop Tin SMD	Harwin Plc.	S1751-46R
1	L1	Choke, SMD, 4.7 μ H	Würth Elektronik	7447779004
4	LD1, LD2, LD3, LD4	LED, HI BRIGHT, 51.7LM, Warm White	Cree, Inc.	MLEAWT-A1-R250-0004E5
1	R1	Resistor, 1206 0R0	Welwyn Components	WCR1206-R005JI
1	R2	Resistor 1 M Ω 1/10W 1% 0603 SMD	Panasonic® - ECG	ERJ-3EKF1004V
3	RB1, RB2, RB3	Resistor TKF 10R 1% 1/10W SMD 0603	Stackpole Electronics, Inc.	RMCF0603FT10R0
1	SW1	2.54 mm SW_SMD_DIP X1	Würth Elektronik	418121270801
1	SW2	2.54mm SW_SMD_DIP X2	Würth Elektronik	418121270802
1	U1	Led Driver, Boost Converter	Microchip Technology Inc.	MCP1662T-E/OT

Note 1: The components listed in this Bill of Materials are representative of the PCB assembly. The released BOM used in manufacturing uses all RoHS-compliant components.



MICROCHIP

Worldwide Sales and Service

AMERICAS

Corporate Office
2355 West Chandler Blvd.
Chandler, AZ 85224-6199
Tel: 480-792-7200
Fax: 480-792-7277
Technical Support:
<http://www.microchip.com/support>
Web Address:
www.microchip.com

Atlanta
Duluth, GA
Tel: 678-957-9614
Fax: 678-957-1455

Austin, TX
Tel: 512-257-3370

Boston
Westborough, MA
Tel: 774-760-0087
Fax: 774-760-0088

Chicago
Itasca, IL
Tel: 630-285-0071
Fax: 630-285-0075

Cleveland
Independence, OH
Tel: 216-447-0464
Fax: 216-447-0643

Dallas
Addison, TX
Tel: 972-818-7423
Fax: 972-818-2924

Detroit
Novi, MI
Tel: 248-848-4000

Houston, TX
Tel: 281-894-5983

Indianapolis
Noblesville, IN
Tel: 317-773-8323
Fax: 317-773-5453

Los Angeles
Mission Viejo, CA
Tel: 949-462-9523
Fax: 949-462-9608

New York, NY
Tel: 631-435-6000

San Jose, CA
Tel: 408-735-9110

Canada - Toronto
Tel: 905-673-0699
Fax: 905-673-6509

ASIA/PACIFIC

Asia Pacific Office
Suites 3707-14, 37th Floor
Tower 6, The Gateway
Harbour City, Kowloon
Hong Kong
Tel: 852-2943-5100
Fax: 852-2401-3431

Australia - Sydney
Tel: 61-2-9868-6733
Fax: 61-2-9868-6755

China - Beijing
Tel: 86-10-8569-7000
Fax: 86-10-8528-2104

China - Chengdu
Tel: 86-28-8665-5511
Fax: 86-28-8665-7889

China - Chongqing
Tel: 86-23-8980-9588
Fax: 86-23-8980-9500

China - Hangzhou
Tel: 86-571-8792-8115
Fax: 86-571-8792-8116

China - Hong Kong SAR
Tel: 852-2943-5100
Fax: 852-2401-3431

China - Nanjing
Tel: 86-25-8473-2460
Fax: 86-25-8473-2470

China - Qingdao
Tel: 86-532-8502-7355
Fax: 86-532-8502-7205

China - Shanghai
Tel: 86-21-5407-5533
Fax: 86-21-5407-5066

China - Shenyang
Tel: 86-24-2334-2829
Fax: 86-24-2334-2393

China - Shenzhen
Tel: 86-755-8864-2200
Fax: 86-755-8203-1760

China - Wuhan
Tel: 86-27-5980-5300
Fax: 86-27-5980-5118

China - Xian
Tel: 86-29-8833-7252
Fax: 86-29-8833-7256

China - Xiamen
Tel: 86-592-2388138
Fax: 86-592-2388130

China - Zhuhai
Tel: 86-756-3210040
Fax: 86-756-3210049

ASIA/PACIFIC

India - Bangalore
Tel: 91-80-3090-4444
Fax: 91-80-3090-4123

India - New Delhi
Tel: 91-11-4160-8631
Fax: 91-11-4160-8632

India - Pune
Tel: 91-20-3019-1500

Japan - Osaka
Tel: 81-6-6152-7160
Fax: 81-6-6152-9310

Japan - Tokyo
Tel: 81-3-6880-3770
Fax: 81-3-6880-3771

Korea - Daegu
Tel: 82-53-744-4301
Fax: 82-53-744-4302

Korea - Seoul
Tel: 82-2-554-7200
Fax: 82-2-558-5932 or
82-2-558-5934

Malaysia - Kuala Lumpur
Tel: 60-3-6201-9857
Fax: 60-3-6201-9859

Malaysia - Penang
Tel: 60-4-227-8870
Fax: 60-4-227-4068

Philippines - Manila
Tel: 63-2-634-9065
Fax: 63-2-634-9069

Singapore
Tel: 65-6334-8870
Fax: 65-6334-8850

Taiwan - Hsin Chu
Tel: 886-3-5778-366
Fax: 886-3-5770-955

Taiwan - Kaohsiung
Tel: 886-7-213-7830

Taiwan - Taipei
Tel: 886-2-2508-8600
Fax: 886-2-2508-0102

Thailand - Bangkok
Tel: 66-2-694-1351
Fax: 66-2-694-1350

EUROPE

Austria - Wels
Tel: 43-7242-2244-39
Fax: 43-7242-2244-393

Denmark - Copenhagen
Tel: 45-4450-2828
Fax: 45-4485-2829

France - Paris
Tel: 33-1-69-53-63-20
Fax: 33-1-69-30-90-79

Germany - Dusseldorf
Tel: 49-2129-3766400

Germany - Munich
Tel: 49-89-627-144-0
Fax: 49-89-627-144-44

Germany - Pforzheim
Tel: 49-7231-424750

Italy - Milan
Tel: 39-0331-742611
Fax: 39-0331-466781

Italy - Venice
Tel: 39-049-7625286

Netherlands - Drunen
Tel: 31-416-690399
Fax: 31-416-690340

Poland - Warsaw
Tel: 48-22-3325737

Spain - Madrid
Tel: 34-91-708-08-90
Fax: 34-91-708-08-91

Sweden - Stockholm
Tel: 46-8-5090-4654

UK - Wokingham
Tel: 44-118-921-5800
Fax: 44-118-921-5820

03/25/14



Компания «ЭлектроПласт» предлагает заключение долгосрочных отношений при поставках импортных электронных компонентов на взаимовыгодных условиях!

Наши преимущества:

- Оперативные поставки широкого спектра электронных компонентов отечественного и импортного производства напрямую от производителей и с крупнейших мировых складов;
- Поставка более 17-ти миллионов наименований электронных компонентов;
- Поставка сложных, дефицитных, либо снятых с производства позиций;
- Оперативные сроки поставки под заказ (от 5 рабочих дней);
- Экспресс доставка в любую точку России;
- Техническая поддержка проекта, помощь в подборе аналогов, поставка прототипов;
- Система менеджмента качества сертифицирована по Международному стандарту ISO 9001;
- Лицензия ФСБ на осуществление работ с использованием сведений, составляющих государственную тайну;
- Поставка специализированных компонентов (Xilinx, Altera, Analog Devices, Intersil, Interpoint, Microsemi, Aeroflex, Peregrine, Syfer, Eurofarad, Texas Instrument, Miteq, Cobham, E2V, MA-COM, Hittite, Mini-Circuits, General Dynamics и др.);

Помимо этого, одним из направлений компании «ЭлектроПласт» является направление «Источники питания». Мы предлагаем Вам помощь Конструкторского отдела:

- Подбор оптимального решения, техническое обоснование при выборе компонента;
- Подбор аналогов;
- Консультации по применению компонента;
- Поставка образцов и прототипов;
- Техническая поддержка проекта;
- Защита от снятия компонента с производства.



Как с нами связаться

Телефон: 8 (812) 309 58 32 (многоканальный)

Факс: 8 (812) 320-02-42

Электронная почта: org@eplast1.ru

Адрес: 198099, г. Санкт-Петербург, ул. Калинина, дом 2, корпус 4, литера А.