

LPS350 Series

350 Watts

Total Power: 350 Watts
Input Voltage: 85-264 Vac
120 - 300 Vdc
of Outputs: Single



Special Features

- Active power factor correction
- IEC EN61000-3-2 compliance
- Remote sense on
- Power fail and remote inhibit
- Single wire current sharing
- Built-in EMI filter
- Adjustable floating 4th output
- 2 Supervisory output 5 V and 12 V
- Overvoltage protection
- Overload protection
- Thermal overload protection
- DC power good
- 130 KHz switching frequency
- Optional with fan cover -CF
- Cover -C
- Optional end-mounted fan -CEF

Safety

VDE	0805/EN60950 (IEC950) 21310-3336-0001
UL	UL1950 EI86249
CSA	CSA 22.2-234 Level 5 LR109492C
NEMKO	EN 60950/EMKO-TUE P98102115 (74-sec) 203
BABT	EN60950/BS7002 608857, 608858, 609097
CB	Certificate and report 5734, 6280, 6281
CE	Mark (LVD)

Electrical Specifications

Input

Input range	85 - 264 VAC; 120 - 300 VDC
Frequency	47 - 440 Hz
Inrush current	38 A max, cold start @ 25 °C
Efficiency	75% typical at full load
EMI filter	FCC Class B conducted and radiated CISPR 22 Class B conducted and radiated EN55022 Class B conducted and radiated VDE 0878 PT3 Class B conducted and radiated
Power factor	0.99 typical
Safety ground leakage current	0.5 mA @ 50/60 Hz, 264 VAC input

Output

Maximum power	With cover: 350 W with 30 CFM forced air, (-C) (-CF) (-CEF)
Adjustment range	2:1 wide ratio
Supervisory output	5 V @ 500 mA regulated, 12 @ 150 mA x2
Hold-up time	20 ms @ 350 W load, 115 VAC nominal line at factory voltage settings
Overload protection	Short circuit protection on all outputs. Case overload protected @ 110 - 145% above peak rating
Overvoltage protection	5 V output: 5.7 - 6.7 VDC. Other models 10% to 25% above nominal output



Logic Control

Power failure	TTL logic signal goes high 50 - 150 msec after 5 V output. It goes low at least 4 msec before loss of regulation
Remote on/off	Requires an external contact (N.O or N.C) to inhibit outputs
DC-OK	TTL logic goes high 50 - 150 msec after 5 V output. It goes low when there is loss of regulation
Remote sense	Compensates for 0.5 V lead drop min. Will operate without remote sense connected. Reverse connection protected

Environmental Specifications

Operating temperature:	0° to 50°C ambient; derate each output at 2.5% per degree from 50° to 70 °C
Storage temperature:	-40 °C to +85 °C
Temperature coefficient:	± 0.4% per °C
Electromagnetic susceptibility:	Designed to meet IEC 801, -2, -3, -4, -5, -6, Level 3
Humidity:	Operating; non-condensing 5% to 95%
Vibration:	Three orthogonal axes, sweep at 1 oct/min, 5 min. dwell at four major resonances 0.7 G peak 5Hz to 500Hz, operational
MTBF demonstrated:	> 550,000 hours at full load and 25 °C ambient conditions

Ordering Information

Model Number	Output Voltage	Minimum Load	Maximum Load with Convection Cooling	Peak Load 1	Regulation 2	Ripple P/P (PARD) ³
LPS352-C	5 V (3 - 6 V)	0 A	70 A	80 A	± 2%	50 mV
LPS353-C	12 V (6 - 12 V)	0 A	29.2 A	33 A	± 2%	120 mV
LPS354-C	15 V (12 - 24 V)	0 A	23.3 A	26 A	± 2%	150 mV
LPS355-C	24 V (24 - 48 V)	0 A	14.6 A	16 A	± 2%	240 mV

1. Peak current lasting < 30 seconds with a maximum 10% duty cycle.
2. At 25 °C including initial tolerance, line voltage, load currents and output voltages adjusted to factory settings.
3. Peak-to-peak with 20 MHz bandwidth and 10 µF in parallel with a 0.1 µF capacitor at rated line voltage and load ranges.
4. 4th output 3.3 - 24 V factory set at 5 V. If optional CF or CEF fans are not used, 30CFM forced air cooling needs to be provided and is required through the length of the power supply. Not convection rated.
5. Output voltage adjustment requires a 1A load.
6. Remote inhibit resets OVP latch.

Note: -CF suffix added to the model number indicates cover with fan,
-CEF suffix added to model number indicates end-mounted fan chassis.

Pin Assignments

SK1	PIN 1	Neutral
	PIN 2	Line
	PIN 3	Ground
SK3	PIN 1	N/C
	PIN 2	N/C
	PIN 3	+ Sense
	PIN 4	- Sense
	PIN 5	POK
	PIN 6	C. Share
	PIN 7	DC - OK
	PIN 8	Inhibit (N.O.)
	PIN 9	Inhibit (N.C.)
	PIN 10	COM
SK4	PIN 1	+ Fan 1 (12V@150mA)
	PIN 2	- Common
SK5	PIN 1	+ 5V aux (5V@100mA)
	PIN 2	- Common
SK6	PIN 1	+ Fan 2 (12V@150mA)
	PIN 2	- Common

Mating Connectors

SK3	Molex: 22-01-1104 PINS: 08-70-0057
SK4	Molex 22-01-3027 PINS: 08-50-0114
SK5	Molex 22-01-3027 PINS: 08-50-0114
SK6	Molex 22-01-3027 PINS: 08-50-0114

Astec Connector Kit #70-841-011, includes all of the above.

Mechanical Drawing

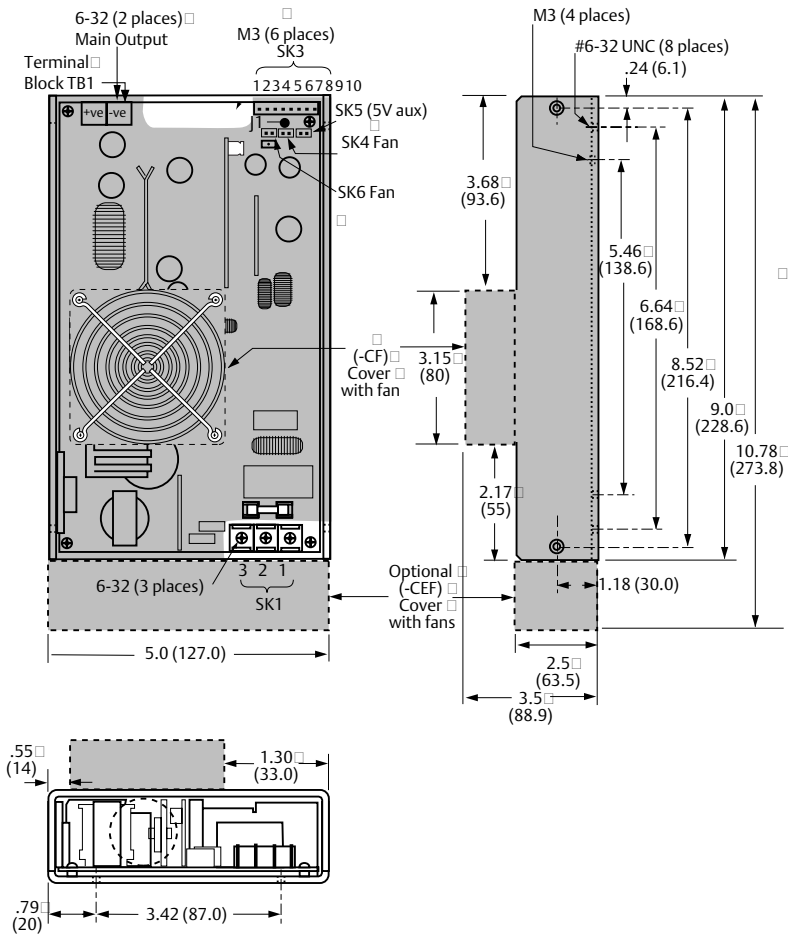

Notes:

1. Specifications subject to change without notice.
2. All dimensions in inches (mm), tolerance is $\pm .02$ ".
3. Specifications are at factory settings
4. To enable normally closed Remote Inhibit, cut jumper J1.
5. Mounting maximum insertion depth is 0.12".
6. Warranty: 2 year
7. Weight: 3.6 lb. / 1.64 kg.

Americas

5810 Van Allen Way
Carlsbad, CA 92008
USA
Telephone: +1 760 930 4600
Facsimile: +1 760 930 0698

Europe (UK)

Waterfront Business Park
Merry Hill, Dudley
West Midlands, DY5 1LX
United Kingdom
Telephone: +44 (0) 1384 842 211
Facsimile: +44 (0) 1384 843 355

Asia (HK)

14/F, Lu Plaza
2 Wing Yip Street
Kwun Tong, Kowloon
Hong Kong
Telephone: +852 2176 3333
Facsimile: +852 2176 3888

For global contact, visit:

www.Emerson.com/EmbeddedPower
techsupport.embeddedpower@emerson.com

While every precaution has been taken to ensure accuracy and completeness in this literature, Emerson Network Power assumes no responsibility, and disclaims all liability for damages resulting from use of this information or for any errors or omissions.

Emerson Network Power.

The global leader in enabling business-critical continuity.

- AC Power
- Connectivity
- DC Power
- Embedded Computing
- Embedded Power
- Monitoring
- Outside Plant
- Power Switching & Controls
- Precision Cooling
- Racks & Integrated Cabinets
- Services
- Surge Protection

EmersonNetworkPower.com

Emerson Network Power and the Emerson Network Power logo are trademarks and service marks of Emerson Electric Co.
©2010 Emerson Electric Co.



Компания «ЭлектроПласт» предлагает заключение долгосрочных отношений при поставках импортных электронных компонентов на взаимовыгодных условиях!

Наши преимущества:

- Оперативные поставки широкого спектра электронных компонентов отечественного и импортного производства напрямую от производителей и с крупнейших мировых складов;
- Поставка более 17-ти миллионов наименований электронных компонентов;
- Поставка сложных, дефицитных, либо снятых с производства позиций;
- Оперативные сроки поставки под заказ (от 5 рабочих дней);
- Экспресс доставка в любую точку России;
- Техническая поддержка проекта, помощь в подборе аналогов, поставка прототипов;
- Система менеджмента качества сертифицирована по Международному стандарту ISO 9001;
- Лицензия ФСБ на осуществление работ с использованием сведений, составляющих государственную тайну;
- Поставка специализированных компонентов (Xilinx, Altera, Analog Devices, Intersil, Interpoint, Microsemi, Aeroflex, Peregrine, Syfer, Eurofarad, Texas Instrument, Miteq, Cobham, E2V, MA-COM, Hittite, Mini-Circuits, General Dynamics и др.);

Помимо этого, одним из направлений компании «ЭлектроПласт» является направление «Источники питания». Мы предлагаем Вам помощь Конструкторского отдела:

- Подбор оптимального решения, техническое обоснование при выборе компонента;
- Подбор аналогов;
- Консультации по применению компонента;
- Поставка образцов и прототипов;
- Техническая поддержка проекта;
- Защита от снятия компонента с производства.



Как с нами связаться

Телефон: 8 (812) 309 58 32 (многоканальный)

Факс: 8 (812) 320-02-42

Электронная почта: org@eplast1.ru

Адрес: 198099, г. Санкт-Петербург, ул. Калинина, дом 2, корпус 4, литера А.