



Main

Range of product	OsiSense XU
Series name	Application material handling
Electronic sensor type	Photo-electric sensor
Sensor name	XUY
Sensor design	Compact 50 x 50
Detection system	Diffuse
Material	Plastic
Supply circuit type	DC
Wiring technique	4-wire
Analogue output range	0...10 V
Electrical connection	1 male connector M12, 4 pins
Product specific application	Measuring thickness of mechanical parts Position control of robot arm
Emission	Red laser, pulsed (class 1), wavelength: 650 nm conforming to IEC 825-1
[Sn] nominal sensing distance	45...85 mm

Complementary

Enclosure material	ABS, anti-shock
Pulse frequency	6 kHz
Linearity	< 1 %
Spot diameter	0.03 in (0.8 mm) at 65 mm
Spot dimension	Ø 0.8 mm at 65 mm
Resolution	20 µm
Status LED	1 LED (green) supply on 1 LED (red) dirty
[Us] rated supply voltage	24 V DC with reverse polarity protection
Supply voltage limits	18...28 V DC
Switching capacity in mA	3 mA (overload and short-circuit protection)
Switching frequency	< 40 Hz
Voltage drop	<= 2.4 V (closed state)
Current consumption	35 mA (no-load)
Delay response	30 ms output circuit
Setting-up	Parametering by buttons
Product weight	0.13 lb(US) (0.057 kg)

Environment

product certifications	CE
ambient air temperature for operation	32...113 °F (0...45 °C)
ambient air temperature for storage	-4...140 °F (-20...60 °C)
immunity to ambient light	5000 lux with natural light
vibration resistance	7 gn, amplitude = +/- 1.5 mm (f = 10...55 Hz) conforming to IEC 60068-2-6
shock resistance	30 gn (duration = 11 ms) conforming to IEC 60068-2-27
IP degree of protection	IP67 conforming to IEC 60529

Offer Sustainability

WARNING: This product can expose you to chemicals including:

WARNING: This product can expose you to chemicals including:

The information provided in this documentation contains general descriptions and/or technical characteristics of the products contained herein. This documentation is not intended as a substitute for and is not to be used for determining suitability or reliability of these products for specific user applications. It is the duty of any such user or integrator to perform the appropriate and complete risk analysis, evaluation and testing of the products with respect to the relevant specific application or use thereof. Neither Schneider Electric Industries SAS nor any of its affiliates or subsidiaries shall be responsible or liable for misuse of the information contained herein.

Diisononyl phthalate (DINP), which is known to the State of California to cause cancer, and Diisononyl phthalate (DINP), which is known to the State of California to cause cancer, and

Diisodecyl phthalate (DIDP), which is known to the State of California to cause birth defects or other reproductive harm. Diisodecyl phthalate (DIDP), which is known to the State of California to cause birth defects or other reproductive harm.

For more information go to www.p65warnings.ca.gov For more information go to www.p65warnings.ca.gov

Contractual warranty

Warranty period 18 months

Dimensions

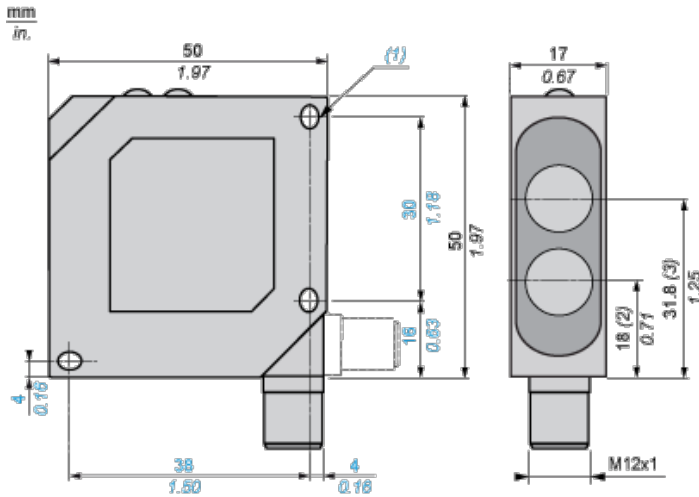

- (1) 2 elongated holes \varnothing 4.3 x 4
- (2) Transmitter optical axis
- (3) Receiver optical axis

Wiring Schemes

M12

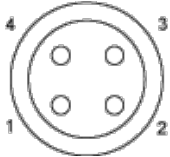

- 1 : Brown
- 2 : White
- 3 : Blue
- 4 : Black

PNP Output

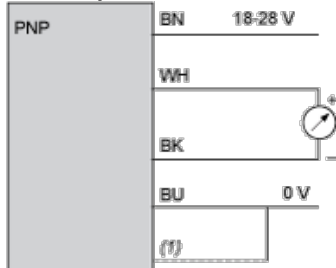

- (+) Brown
- BN :
- WH :White
- (-) Blue
- BU :
- BK : Black
- (1) Shielding

NOTE: Shielded cable recommended

Adjustment Curves

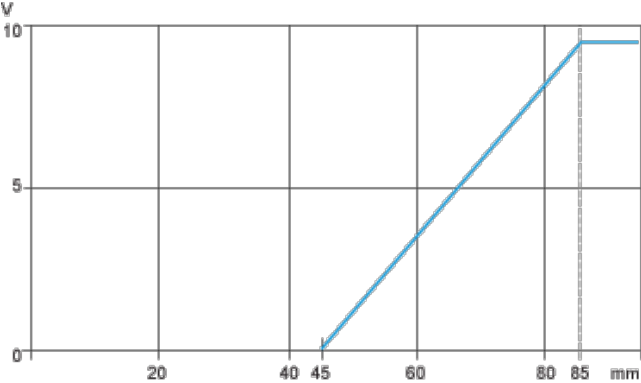



Компания «ЭлектроПласт» предлагает заключение долгосрочных отношений при поставках импортных электронных компонентов на взаимовыгодных условиях!

Наши преимущества:

- Оперативные поставки широкого спектра электронных компонентов отечественного и импортного производства напрямую от производителей и с крупнейших мировых складов;
- Поставка более 17-ти миллионов наименований электронных компонентов;
- Поставка сложных, дефицитных, либо снятых с производства позиций;
- Оперативные сроки поставки под заказ (от 5 рабочих дней);
- Экспресс доставка в любую точку России;
- Техническая поддержка проекта, помощь в подборе аналогов, поставка прототипов;
- Система менеджмента качества сертифицирована по Международному стандарту ISO 9001;
- Лицензия ФСБ на осуществление работ с использованием сведений, составляющих государственную тайну;
- Поставка специализированных компонентов (Xilinx, Altera, Analog Devices, Intersil, Interpoint, Microsemi, Aeroflex, Peregrine, Syfer, Eurofarad, Texas Instrument, Miteq, Cobham, E2V, MA-COM, Hittite, Mini-Circuits, General Dynamics и др.);

Помимо этого, одним из направлений компании «ЭлектроПласт» является направление «Источники питания». Мы предлагаем Вам помощь Конструкторского отдела:

- Подбор оптимального решения, техническое обоснование при выборе компонента;
- Подбор аналогов;
- Консультации по применению компонента;
- Поставка образцов и прототипов;
- Техническая поддержка проекта;
- Защита от снятия компонента с производства.



Как с нами связаться

Телефон: 8 (812) 309 58 32 (многоканальный)

Факс: 8 (812) 320-02-42

Электронная почта: org@eplast1.ru

Адрес: 198099, г. Санкт-Петербург, ул. Калинина, дом 2, корпус 4, литера А.