

**Pin Programmable  
Universal and Bandpass Filters**

**General Description**

**Features**

The MAX263/264 and MAX267/268 CMOS switched-capacitor active filters are designed for precision filtering applications. Center frequency, Q, and operating mode are all selected via pin-strapped inputs. The MAX263/264 uses no external components for a variety of bandpass, lowpass, highpass, notch and allpass filters. The MAX267/268 is dedicated to bandpass applications and includes an uncommitted op-amp. Two second-order filter sections are included in both devices.

- ◆ 32-Step Center Frequency Control
- ◆ 128-Step Q Control
- ◆ Independent Q and  $f_0$  Programming
- ◆ Guaranteed Clock to  $f_0$  Ratio—1% (A grade)
- ◆ 75kHz  $f_0$  Range (MAX264/268)
- ◆ Single +5V and  $\pm 5V$  Operation

An input clock and a 5-bit programming input precisely set the filter center/corner frequency. Q is also programmed from 0.5 to 64. Separate clock inputs for each filter half operate with either an external clock or a crystal.

**Ordering Information**

The MAX263 and 267 operate with center frequencies up to 57kHz while the MAX264 and 268 extend the  $f_0$  range to 140kHz by employing lower  $f_{CLK}/f_0$  ratios. The MAX263/264 is supplied in 28 pin wide DIP and small outline packages while the MAX267/268 is supplied in 24 pin narrow DIP and wide SO packages. All devices are available in commercial, extended, and military temperature ranges.

PART	TEMP. RANGE	PACKAGE*	ACCURACY
MAX263ACPI	0°C to +70°C	Plastic DIP	1%
MAX263BCPI	0°C to +70°C	Plastic DIP	2%
MAX263AEPI	-40°C to +85°C	Plastic DIP	1%
MAX263BEPI	-40°C to +85°C	Plastic DIP	2%
MAX263ACWI	0°C to +70°C	Wide SO	1%
MAX263BCWI	0°C to +70°C	Wide SO	2%
MAX263AMJI	-55°C to +125°C	CERDIP	1%
MAX263BMJI	-55°C to +125°C	CERDIP	2%
MAX264ACPI	0°C to +70°C	Plastic DIP	1%
MAX264BCPI	0°C to +70°C	Plastic DIP	2%

**Applications**

- Sonar and Avionics Instruments
- Anti-Aliasing Filters
- Digital Signal Processing
- Vibration and Audio Analysis
- Matched Tracking Filters

(Ordering Information continued at end of data sheet.)

\* MAX263/264 packages are 28-pin 0.6" wide DIP and 28-pin 0.3" wide SO (Small Outline).

MAX267/268 packages are 24-pin 0.3" narrow DIP and 24-pin 0.3" wide SO (Small Outline).

**Typical Application**

**Pin Configuration**



# MAX263/MAX264/MAX267/MAX268

## Pin Programmable Universal and Bandpass Filters

### ABSOLUTE MAXIMUM RATINGS

Total Supply Voltage ( $V^+$ to $V^-$ )	15V
Input Voltage, any pin	$V^- - 0.3V$ to $V^+ + 0.3V$
Input Current, any pin	$\pm 50mA$
Power Dissipation	
Plastic DIP (derate 8.33mW/°C above 70°C)	660mW
CERDIP (derate 12.5mW/°C above 70°C)	1000mW
Wide SO (derate 11.8mW/°C above 70°C)	944mW

Operating Temperature	
MAX26XXCXX	0°C to +70°C
MAX26XXEXX	-40°C to +85°C
MAX26XXMXX	-55°C to +125°C
Storage Temperature	-65°C to +160°C
Lead Temperature (Soldering, 10 seconds)	+300°C

Stresses above those listed under "Absolute Maximum Ratings" may cause permanent damage to the device. These are stress ratings only, and functional operation of the device at these or any other conditions above those indicated in the operational sections of the specification is not implied. Exposure to absolute Maximum ratings conditions for extended periods may affect the device reliability.

### ELECTRICAL CHARACTERISTICS

( $V^+ = +5V$ ,  $V^- = -5V$ ,  $CLK_A = CLK_B = \pm 5V$ , 1.5MHz,  $f_{CLK}/f_0 = 197.92$  for MAX263/67 and 138.23 for MAX264/68, Filter Mode 1, "1" =  $V^+$  and "0" =  $V^-$  on F and Q inputs,  $T_A = +25^\circ C$  unless otherwise noted.)

PARAMETER	CONDITIONS		MIN	TYP	MAX	UNITS
$f_0$ Center Frequency Range			See Table 1			
Maximum Clock Frequency			See Table 1			
$f_{CLK}/f_0$ Ratio Error (Note 1)	$T_A = T_{MIN}$ to $T_{MAX}$	MAX26XA MAX26XB		$\pm 0.2$ $\pm 0.2$	$\pm 1.0$ $\pm 2.0$	%
$f_0$ Temperature Coefficient				-5		ppm/°C
Q Accuracy (deviation from ideal continuous filter) (Note 2)	$T_A = T_{MIN}$ to $T_{MAX}$ Q = 0.5 to 8 Q = 0.5 to 8 Q = 16 to 32 Q = 16 to 32 Q = 64 Q = 64	MAX26XA MAX26XB MAX26XA MAX26XB MAX26XA MAX26XB		$\pm 1$ $\pm 1$ $\pm 2$ $\pm 2$ $\pm 4$ $\pm 4$	$\pm 6$ $\pm 10$ $\pm 10$ $\pm 15$ $\pm 20$ $\pm 25$	%
Q Temperature Coefficient				$\pm 20$		ppm/°C
DC Lowpass Gain Accuracy		MAX263/4		$\pm 0.1$	$\pm 0.5$	dB
Gain Temperature Coefficient	Lowpass (at D.C.) Bandpass (at $f_0$ )			-5 +20		ppm/°C
Output Offset Voltage (Note 3)	$T_A = T_{MIN}$ to $T_{MAX}$ , Q = 4 Mode 1 BP Output	MAX263/67A MAX263/67B MAX264/68A MAX264/68B		$\pm 0.05$ $\pm 0.05$ $\pm 0.05$ $\pm 0.05$	$\pm 0.20$ $\pm 0.30$ $\pm 0.20$ $\pm 0.30$	V
		MAX263A MAX263B MAX264A MAX264B		$\pm 0.40$ $\pm 0.80$ $\pm 0.40$ $\pm 0.80$	$\pm 1.00$ $\pm 1.60$ $\pm 1.20$ $\pm 1.60$	
		MAX263A MAX263B MAX264A MAX264B		$\pm 0.10$ $\pm 0.10$ $\pm 0.10$ $\pm 0.10$	$\pm 0.20$ $\pm 0.30$ $\pm 0.20$ $\pm 0.30$	
		MAX263A MAX263B MAX264A MAX264B		$\pm 0.50$ $\pm 0.90$ $\pm 0.50$ $\pm 0.90$	$\pm 1.10$ $\pm 1.60$ $\pm 1.30$ $\pm 1.60$	
Offset Voltage Temperature Coefficient	$f_{CLK}/f_0 = 100.53$ , Q = 4 $T_A = T_{MIN}$ to $T_{MAX}$			$\pm 0.75$		mV/°C
Clock Feedthrough				$\pm 4$		mV
Crosstalk				-70		dB
Wideband Noise (Note 4)	Q = 1, 2nd-Order, LP/BP 4th-Order LP 4th-Order BP		See Typ. Oper. Char. 90 100			$\mu V_{RMS}$

# MAX263/MAX264/MAX267/MAX268

## Pin Programmable Universal and Bandpass Filters

### ELECTRICAL CHARACTERISTICS (Continued)

( $V^+ = +5V$ ,  $V^- = -5V$ ,  $CLK_A = CLK_B = \pm 5V$ , 1.5MHz,  $f_{CLK}/f_0 = 197.92$  for MAX263/67 and 138.23 for MAX264/68, Filter Mode 1, "1" =  $V^+$  and "0" =  $V^-$  on F and Q inputs,  $T_A = +25^\circ C$  unless otherwise noted.)

PARAMETER	CONDITIONS	MIN	TYP	MAX	UNITS
Harmonic Distortion at $f_0$	$Q = 4$ , $V_{IN} = 1.5V_{PP}$		-67		dB
Supply Voltage Range	$T_A = T_{MIN}$ to $T_{MAX}$	$\pm 2.37$	$\pm 5$	$\pm 6.3$	V
Power Supply Current (Note 5)	$T_A = T_{MIN}$ to $T_{MAX}$		14 14	20 20	mA
Shutdown Supply Current (Note 5)	Q0-Q6 = all 0		2.5		mA
$f_0$ , Q Programming Inputs	$T_A = T_{MIN}$ to $T_{MAX}$ , F0-F4, Q0-Q6 High Threshold Low Threshold	$V^+ - 0.5$		$V^- + 0.5$	V
Clock Inputs	$T_A = T_{MIN}$ to $T_{MAX}$ , $CLK_A$ , $CLK_B$ High Threshold Low Threshold	2.4		0.8	V
Input Leakage Current	$T_A = T_{MIN}$ to $T_{MAX}$ $CLK_B = V^+$ or $V^-$ $CLK_A = V^+$ or $V^-$ M0, M1, F0-F4, Q0-Q6 = $V^+ - 0.5V$ or $V^- + 0.5V$ M0, M1, F0-F4, Q0-Q6 = $V^+$ or $V^-$		6 20 5	10 60 200	$\mu A$
<b>INTERNAL AMPLIFIERS</b>					
Output Signal Swing	$T_A = T_{MIN}$ to $T_{MAX}$ , 10k $\Omega$ load		$\pm 4.75$		V
Output Short Circuit Current	Source Sink		50 2		mA
Power Supply Rejection Ratio	0Hz to 10kHz		-70		dB
Gain Bandwidth Product			2.5		MHz
Slew Rate			6		V/ $\mu s$

### ELECTRICAL CHARACTERISTICS (for $V_{\pm} = \pm 2.5V \pm 5\%$ )

( $V^+ = +2.37V$ ,  $V^- = -2.37V$ ,  $CLK_A = CLK_B = \pm 2.5V$  1MHz  $f_{CLK}/f_0 = 197.92$  for the MAX263/67 and 138.23 for MAX264/68, Filter Mode 1,  $T_A = +25^\circ C$  unless otherwise noted.)

PARAMETER	CONDITIONS	MIN	TYP	MAX	UNITS
$f_0$ Center Frequency Range			(Note 6)		
Maximum Clock Frequency			(Note 6)		
$f_{CLK}/f_0$ Ratio Error (Notes 1, 7)	$Q = 8$		$\pm 0.1$ $\pm 0.1$	$\pm 1$ $\pm 2$	%
Q Accuracy (deviation from ideal continuous filter) (Notes 2, 7)	$Q = 8$ $f_{CLK}/f_0 = 197.92$ $f_{CLK}/f_0 = 138.23$		$\pm 2$ $\pm 2$ $\pm 2$	$\pm 6$ $\pm 10$ $\pm 6$ $\pm 10$	%
Output Signal Swing	All Outputs		$\pm 2$		V
Power Supply Current			7		mA
Shutdown Current			0.45		mA

**Note 1:**  $f_{CLK}/f_0$  accuracy is tested at 197.92 on the MAX263/67, and at 138.23 on the MAX264/68.

**Note 2:** Q accuracy tested at  $Q = 8, 32$ , and 64. Q of 32 and 64 tested at 1/2 stated clock frequency.

**Note 3:** The Offset Voltage is specified for the entire filter. Offset is virtually independent of Q and  $f_{CLK}/f_0$  ratio setting. The test clock frequency for Mode 3 is 750kHz.

**Note 4:** Output noise is measured with an RC output smoothing filter at  $4 \times f_0$  to remove clock feedthrough.

**Note 5:** TTL logic levels are: HIGH = 2.4V, LOW = 0.8V. Power supply current is typically 4mA higher with TTL clock input levels.

**Note 6:** At  $\pm 2.5V$  supplies, the  $f_0$  range and maximum clock frequency are typically 75% of values listed in Table 1.

**Note 7:**  $f_{CLK}/f_0$  and Q accuracy are a function of the accuracy of internal capacitor ratios. No increase in error is expected at  $\pm 2.5V$  as compared to  $\pm 5V$ , however these parameters are only tested to the extent indicated by the MIN or MAX limits.



# MAX263/MAX264/MAX267/MAX268

## Pin Programmable Universal and Bandpass Filters

### Typical Operating Characteristics

**IDD vs POWER SUPPLY VOLTAGE**

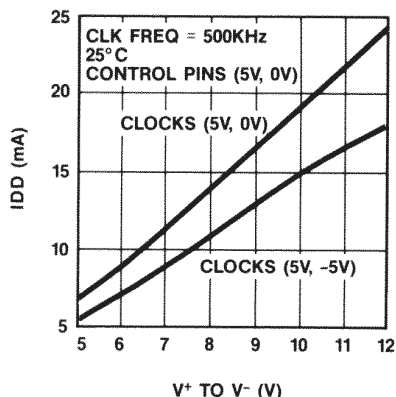

**IDD vs CLOCK FREQUENCY**



**Q vs CLOCK FREQUENCY**



**f<sub>CLK</sub>/f<sub>0</sub> vs CLOCK FREQUENCY**

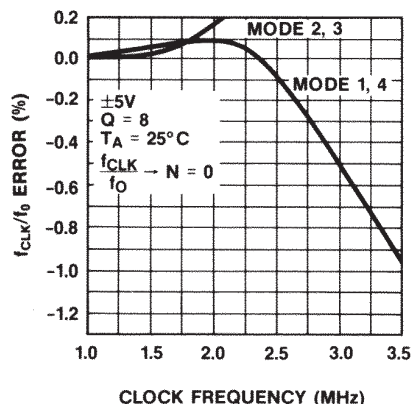

**ω<sub>0</sub> vs f<sub>0</sub>**

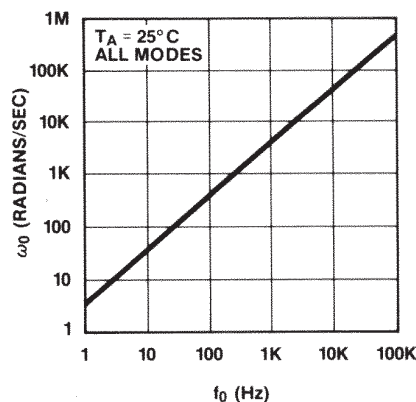

### Wideband RMS Noise (db ref. to 2.47V<sub>RMS</sub>, 7V<sub>p-p</sub>), ±5V Operation

Mode	Q = 1			Q = 8			Q = 64		
	LP	BP	HP/AP/N	LP	BP	HP/AP/N	LP	BP	HP/AP/N
1	-84	-90	-84	-80	-82	-85	-72	-73	-85
2	-88	-90	-88	-84	-82	-84	-77	-73	-76
3	-84	-90	-88	-80	-82	-82	-73	-73	-74
4	-83	-89	-84	-79	-81	-85	-71	-73	-85

#### Notes:

- f<sub>CLK</sub> = 1MHz
- f<sub>CLK</sub>/f<sub>0</sub> ratio programmed at N = 31 (see Table 2)
- Clock feedthrough is removed with an RC lowpass at 4f<sub>0</sub>, i.e. R = 3.9kΩ, C = 2000pF for MAX263.

### Noise Spectral Distribution

(MAX263/67, f<sub>CLK</sub> = 1 MHz, dB ref. to 2.47V<sub>RMS</sub>, 7V<sub>p-p</sub>)

Measurement Bandwidth	Q=1	Q=8	Q=64
Wideband	-84	-80	-72
3kHz	-87	-87	-86
C Message Weighted	-93	-93	-93

# MAX263/MAX264/MAX267/MAX268

## Pin Programmable Universal and Bandpass Filters

### Pin Description

MAX263 MAX264 PIN #	MAX267 MAX268 PIN #	NAME	FUNCTION
10	8	V <sup>+</sup>	Positive supply voltage
18	16	V <sup>-</sup>	Negative supply voltage
19	17	GND	Analog Ground. Connect to the system ground for dual supply operation or mid-supply for single supply operation. GND should be well bypassed in single supply applications.
13	11	CLK <sub>A</sub>	Input to the oscillator and clock input to section A. This clock is internally divided by 2.
14	12	CLK <sub>B</sub>	Clock input to filter B. This clock is internally divided by 2.
20	18	OSC OUT	Connects to crystal for self clocked operation
5, 1	5, 1	IN <sub>A</sub> , IN <sub>B</sub>	Filter inputs
3, 27	2, 24	BP <sub>A</sub> , BP <sub>B</sub>	Bandpass outputs
2, 28		LP <sub>A</sub> , LP <sub>B</sub>	Lowpass outputs (MAX263/264 only)
4, 26		HP <sub>A</sub> , HP <sub>B</sub>	Highpass/Notch/Allpass outputs (MAX263/264 only)
8, 7		M0, M1	Mode select inputs (MAX267/268 are fixed in Mode 1)
24, 17, 23 12, 11	22, 15, 21 10, 9	F0-F4	Clock/center frequency ratio ( $f_{CLK}/f_0$ ) programming inputs
15, 16, 21 22, 25, 6 9	13, 14, 19 20, 23, 6 7	Q0-Q6	Q programming inputs
	4	OP IN	Inverting input of uncommitted op-amp on MAX267/268 only. Noninverting input is internally connected to ground.
	3	OP OUT	Output of uncommitted op-amp on MAX267/268 only.



# MAX263/MAX264/MAX267/MAX268

## Pin Programmable Universal and Bandpass Filters

### **Detailed Description** **$f_0$ and Q Programming**

Figure 2 shows a block diagram of a complete filter. Each 2nd-order filter section has its own clock input, however, package pin limitations require that  $f_0$ , Q, and Mode control be shared by both sections. The actual center frequency is a function of the filter's clock rate, 5-bit  $f_0$  control word (see Table 2), and operating Mode.

For some filter designs, the MAX263/64/67/68 may require separate clocks for each second-order section since separate programming inputs are not provided. Such designs may be implemented with different clock inputs, or, in the case of bandpass filters, by

using multiple feedback and one clock (see "Description of Filter Functions"). When implementing two or more matched filters, however, the programming restrictions are easily overcome and one clock can still be used as demonstrated by the design example in Figure 21. Another alternative is to use the MAX260/261/262 microprocessor programmed filters or the MAX265/266 resistor programmed filters which allow independent programming of each filter section. Refer to the device data sheets for further details on those products.

# MAX263/MAX264/MAX267/MAX268

## Pin Programmable Universal and Bandpass Filters

Table 1. Typical Clock and Center Frequency Limits (MAX267/268 are operated in Mode 1 only.)

PART	Q	MODE	$f_{CLK}$	$f_0$
MAX263/ 267	1	1	40Hz-4.0MHz	0.4Hz-40kHz
	1	2	40Hz-4.0MHz	0.5Hz-57kHz
	1	3	40Hz-4.0MHz	0.4Hz-40kHz
	1	4	40Hz-4.0MHz	0.4Hz-40kHz
	8	1	40Hz-2.7MHz	0.4Hz-27kHz
	8	2	40Hz-2.1MHz	0.5Hz-30kHz
	8	3	40Hz-1.7MHz	0.4Hz-17kHz
	8	4	40Hz-2.7MHz	0.4Hz-27kHz
64	1	40Hz-2.0MHz	0.4Hz-20kHz	
90	2	40Hz-1.2MHz	0.4Hz-18kHz	
64	3	40Hz-1.2MHz	0.4Hz-12kHz	
64	4	40Hz-2.0MHz	0.4Hz-20kHz	

PART	Q	MODE	$f_{CLK}$	$f_0$
MAX264/ 268	1	1	40Hz-4.0MHz	1.0Hz-100kHz
	1	2	40Hz-4.0MHz	1.4Hz-140kHz
	1	3	40Hz-4.0MHz	1.0Hz-100kHz
	1	4	40Hz-4.0MHz	1.0Hz-100kHz
	8	1	40Hz-2.5MHz	1.0Hz-60kHz
	8	2	40Hz-1.4MHz	1.4Hz-50kHz
	8	3	40Hz-1.4MHz	1.0Hz-35kHz
	8	4	40Hz-2.5MHz	1.0Hz-60kHz
64	1	40Hz-1.5MHz	1.0Hz-37kHz	
90	2	40Hz-0.9MHz	1.4Hz-32kHz	
64	3	40Hz-0.9MHz	1.0Hz-22kHz	
64	4	40Hz-1.5MHz	1.0Hz-37kHz	



Figure 2. MAX263/264/267/268 Block Diagram



# MAX263/MAX264/MAX267/MAX268

## Pin Programmable Universal and Bandpass Filters

Table 2.  $f_{CLK}/f_0$  Program Selection Table

$f_{CLK}/f_0$ RATIO				PROGRAM CODE					
MAX263/67		MAX264/68		N	F4	F3	F2	F1	F0
MODE 1,3,4	MODE 2	MODE 1,3,4	MODE 2						
100.53	71.09	40.84	28.88	0	0	0	0	0	0
103.67	73.31	43.98	31.10	1	0	0	0	0	1
106.81	75.53	47.12	33.32	2	0	0	0	1	0
109.96	77.75	50.27	35.54	3	0	0	0	1	1
113.10	79.97	53.41	37.76	4	0	0	1	0	0
116.24	82.19	56.55	39.99	5	0	0	1	0	1
119.38	84.42	59.69	42.21	6	0	0	1	1	0
122.52	86.64	62.83	44.43	7	0	0	1	1	1
125.66	88.86	65.97	46.65	8	0	1	0	0	0
128.81	91.80	69.12	48.87	9	0	1	0	0	1
131.95	93.30	72.26	51.10	10	0	1	0	1	0
135.08	95.52	75.40	53.31	11	0	1	0	1	1
138.23	97.74	78.53	55.54	12	0	1	1	0	0
141.37	99.97	81.68	57.76	13	0	1	1	0	1
144.51	102.89	84.82	59.98	14	0	1	1	1	0
147.65	104.41	87.96	62.20	15	0	1	1	1	1
150.80	106.63	91.11	64.42	16	1	0	0	0	0
153.98	108.85	94.25	66.64	17	1	0	0	0	1
157.08	111.07	97.39	68.86	18	1	0	0	1	0
160.22	113.29	100.53	71.09	19	1	0	0	1	1
163.36	115.52	102.67	73.31	20	1	0	1	0	0
166.50	117.74	106.81	75.53	21	1	0	1	0	1
169.65	119.96	109.96	77.75	22	1	0	1	1	0
172.79	122.18	113.10	79.97	23	1	0	1	1	1
175.93	124.40	116.24	82.19	24	1	1	0	0	0
179.07	126.62	119.38	84.81	25	1	1	0	0	1
182.21	128.84	122.52	86.64	26	1	1	0	1	0
185.35	131.07	125.66	88.86	27	1	1	0	1	1
188.49	133.29	128.81	91.08	28	1	1	1	0	0
191.64	135.51	131.95	93.30	29	1	1	1	0	1
194.78	137.73	135.09	95.52	30	1	1	1	1	0
197.92	139.95	138.23	97.74	31	1	1	1	1	1

- Notes:**
- 1) For the MAX263/67,  $f_{CLK}/f_0 = \pi(N+32)$  in Mode 1, 3, and 4, where N varies from 0 to 31.
  - 2) For the MAX264/68,  $f_{CLK}/f_0 = \pi(N+13)$  in Mode 1, 3, and 4, where N varies 0 to 31.
  - 3) In Mode 2, all  $f_{CLK}/f_0$  ratios are divided by  $\sqrt{2}$ .

# MAX263/MAX264/MAX267/MAX268

## Pin Programmable Universal and Bandpass Filters

Table 3. Q Program Selection Table (Continued on following page)

PROGRAMMED Q		PROGRAM CODE							
MODE 1,3,4	MODE 2	N	Q6	Q5	Q4	Q3	Q2	Q1	Q0
Note 4	Note 4	0	0	0	0	0	0	0	0
0.504	0.713	1	0	0	0	0	0	0	1
0.508	0.718	2	0	0	0	0	0	1	0
0.512	0.724	3	0	0	0	0	0	1	1
0.516	0.730	4	0	0	0	0	1	0	0
0.520	0.736	5	0	0	0	0	1	0	1
0.525	0.742	6	0	0	0	0	1	1	0
0.529	0.748	7	0	0	0	0	1	1	1
0.533	0.754	8	0	0	0	1	0	0	0
0.538	0.761	9	0	0	0	1	0	0	1
0.542	0.767	10	0	0	0	1	0	1	0
0.547	0.774	11	0	0	0	1	0	1	1
0.552	0.780	12	0	0	0	1	1	0	0
0.556	0.787	13	0	0	0	1	1	0	1
0.561	0.794	14	0	0	0	1	1	1	0
0.566	0.801	15	0	0	0	1	1	1	1
0.571	0.808	16	0	0	1	0	0	0	0
0.577	0.815	17	0	0	1	0	0	0	1
0.582	0.823	18	0	0	1	0	0	1	0
0.587	0.830	19	0	0	1	0	0	1	1
0.593	0.838	20	0	0	1	0	1	0	0
0.598	0.846	21	0	0	1	0	1	0	1
0.604	0.854	22	0	0	1	0	1	1	0
0.609	0.862	23	0	0	1	0	1	1	1
0.615	0.870	24	0	0	1	1	0	0	0
0.621	0.879	25	0	0	1	1	0	0	1
0.627	0.887	26	0	0	1	1	0	1	0
0.634	0.896	27	0	0	1	1	0	1	1
0.640	0.905	28	0	0	1	1	1	0	0
0.646	0.914	29	0	0	1	1	1	0	1
0.653	0.924	30	0	0	1	1	1	1	0
0.660	0.933	31	0	0	1	1	1	1	1
0.667	0.943	32	0	1	0	0	0	0	0
0.674	0.953	33	0	1	0	0	0	0	1
0.681	0.963	34	0	1	0	0	0	1	0
0.688	0.973	35	0	1	0	0	0	1	1
0.696	0.984	36	0	1	0	0	1	0	0
0.703	0.995	37	0	1	0	0	1	0	1
0.711	1.01	38	0	1	0	0	1	1	0
0.719	1.02	39	0	1	0	0	1	1	1
0.727	1.03	40	0	1	0	1	0	0	0
0.736	1.04	41	0	1	0	1	0	0	1
0.744	1.05	42	0	1	0	1	0	1	0
0.753	1.06	43	0	1	0	1	0	1	1
0.762	1.08	44	0	1	0	1	1	0	0
0.771	1.09	45	0	1	0	1	1	0	1
0.780	1.10	46	0	1	0	1	1	1	0
0.790	1.12	47	0	1	0	1	1	1	1

PROGRAMMED Q		PROGRAM CODE							
MODE 1,3,4	MODE 2	N	Q6	Q5	Q4	Q3	Q2	Q1	Q0
0.800	1.13	48	0	1	1	0	0	0	0
0.810	1.15	49	0	1	1	0	0	0	1
0.821	1.16	50	0	1	1	0	0	1	0
0.831	1.18	51	0	1	1	0	0	1	1
0.842	1.19	52	0	1	1	0	1	0	0
0.853	1.21	53	0	1	1	0	1	0	1
0.865	1.22	54	0	1	1	0	1	1	0
0.877	1.24	55	0	1	1	0	1	1	1
0.889	1.26	56	0	1	1	1	0	0	0
0.901	1.27	57	0	1	1	1	0	0	1
0.914	1.29	58	0	1	1	1	0	1	0
0.928	1.31	59	0	1	1	1	0	1	1
0.941	1.33	60	0	1	1	1	1	0	0
0.955	1.35	61	0	1	1	1	1	0	1
0.969	1.37	62	0	1	1	1	1	1	0
0.985	1.39	63	0	1	1	1	1	1	1
1.00	1.41	64	1	0	0	0	0	0	0
1.02	1.44	65	1	0	0	0	0	0	1
1.03	1.46	66	1	0	0	0	0	1	0
1.05	1.48	67	1	0	0	0	0	1	1
1.07	1.51	68	1	0	0	0	1	0	0
1.08	1.53	69	1	0	0	0	1	0	1
1.10	1.56	70	1	0	0	0	1	1	0
1.12	1.59	71	1	0	0	0	1	1	1
1.14	1.62	72	1	0	0	1	0	0	0
1.16	1.65	73	1	0	0	1	0	0	1
1.19	1.68	74	1	0	0	1	0	1	0
1.21	1.71	75	1	0	0	1	0	1	1
1.23	1.74	76	1	0	0	1	1	0	0
1.25	1.77	77	1	0	0	1	1	0	1
1.28	1.81	78	1	0	0	1	1	1	0
1.31	1.85	79	1	0	0	1	1	1	1
1.33	1.89	80	1	0	1	0	0	0	0
1.36	1.93	81	1	0	1	0	0	0	1
1.39	1.97	82	1	0	1	0	0	1	0
1.42	2.01	83	1	0	1	0	0	1	1
1.45	2.06	84	1	0	1	0	1	0	0
1.49	2.10	85	1	0	1	0	1	0	1
1.52	2.16	86	1	0	1	0	1	1	0
1.56	2.21	87	1	0	1	0	1	1	1
1.60	2.26	88	1	0	1	1	0	0	0
1.64	2.32	89	1	0	1	1	0	0	1
1.68	2.40	90	1	0	1	1	0	1	0
1.73	2.45	91	1	0	1	1	0	1	1
1.78	2.51	92	1	0	1	1	1	0	0
1.83	2.59	93	1	0	1	1	1	0	1
1.88	2.66	94	1	0	1	1	1	1	0
1.94	2.74	95	1	0	1	1	1	1	1

Notes: 4) Writing all 0s into Q0-Q6 activates a low power shutdown mode. BOTH filter sections are deactivated. 0 = V-, 1 = V+.

# MAX263/MAX264/MAX267/MAX268

## Pin Programmable Universal and Bandpass Filters

Table 3. Q Program Selection Table (Continued)

PROGRAMMED Q		PROGRAM CODE							
MODE 1,3,4	MODE 2	N	Q6	Q5	Q4	Q3	Q2	Q1	Q0
2.00	2.83	96	1	1	0	0	0	0	0
2.06	2.92	97	1	1	0	0	0	0	1
2.13	3.02	98	1	1	0	0	0	1	0
2.21	3.12	99	1	1	0	0	0	1	1
2.29	3.23	100	1	1	0	0	1	0	0
2.37	3.35	101	1	1	0	0	1	0	1
2.46	3.48	102	1	1	0	0	1	1	0
2.56	3.62	103	1	1	0	0	1	1	1
2.67	3.77	104	1	1	0	1	0	0	0
2.78	3.96	105	1	1	0	1	0	0	1
2.91	4.11	106	1	1	0	1	0	1	0
3.05	4.31	107	1	1	0	1	0	1	1
3.20	4.53	108	1	1	0	1	1	0	0
3.37	4.76	109	1	1	0	1	1	0	1
3.56	5.03	110	1	1	0	1	1	1	0
3.76	5.32	111	1	1	0	1	1	1	1

PROGRAMMED Q		PROGRAM CODE							
MODE 1,3,4	MODE 2	N	Q6	Q5	Q4	Q3	Q2	Q1	Q0
4.00	5.66	112	1	1	1	0	0	0	0
4.27	6.03	113	1	1	1	0	0	0	1
4.57	6.46	114	1	1	1	0	0	1	0
4.92	6.96	115	1	1	1	0	0	1	1
5.33	7.54	116	1	1	1	0	1	0	0
5.82	8.23	117	1	1	1	0	1	0	1
6.40	9.05	118	1	1	1	0	1	1	0
7.11	10.1	119	1	1	1	0	1	1	1
8.00	11.3	120	1	1	1	1	0	0	0
9.14	12.9	121	1	1	1	1	0	0	1
10.7	15.1	122	1	1	1	1	0	1	0
12.8	18.1	123	1	1	1	1	0	1	1
16.0	22.6	124	1	1	1	1	1	0	0
21.3	30.2	125	1	1	1	1	1	0	1
32.0	45.3	126	1	1	1	1	1	1	0
64.0	90.5	127	1	1	1	1	1	1	1

Notes: 5) In Modes 1, 3, and 4:  $Q = 64/(128-N)$

6) In Mode 2, the listed Q values are those of Mode 1 multiplied by  $\sqrt{2}$ . Then  $Q = 90.51/(128-N)$

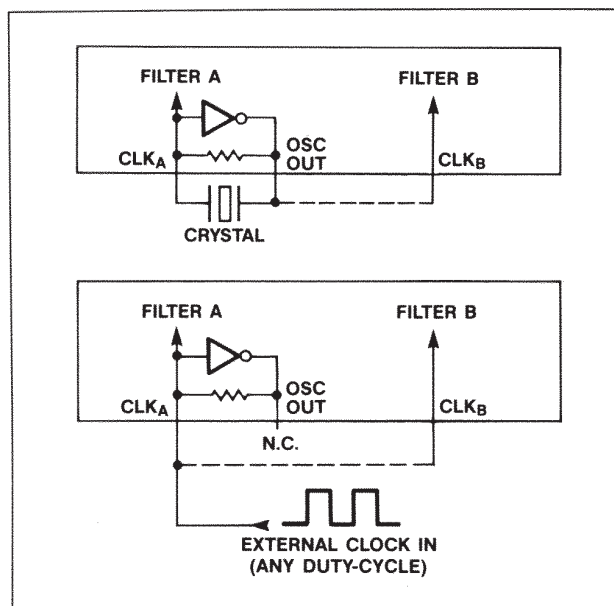

Figure 3. Clock Input Connections

### Oscillator and Clock Inputs

The clock circuitry of the MAX263/64/67/68 can operate with a crystal or an external clock generator as shown in Figure 3. The duty cycle of the clock at  $CLK_A$  and  $CLK_B$  is unimportant because the input is internally divided by two to generate the sampling clock for each filter section. It is important to note that this internal division also halves the sample rate when considering aliasing and other sampled system phenomenon.

### Shutdown Mode

The filter enters a shutdown mode when all Q inputs, Q0-Q6, are tied low. When shut down, power consumption with  $\pm 5V$  supplies typically drops to 25mW. When reactivating the filter after shutdown, allow 2ms to return to full operation.

### Filter Operating Modes (MAX263/264 Only)

The MAX263/264's filter sections can be configured in four basic "Modes" as selected by inputs M0 and M1 (see Table 4). The MAX267/68 operates only in Mode 1. A fifth mode, 3A, uses an external op amp and resistors but is selected the same way and uses the same internal configuration as Mode 3.

Figures 4 through 8 show symbolic representations of the MAX263/64 filter modes. Only one second-order section is shown in each case, however the  $f_0$ , Q, and Mode select inputs are common to both halves of the IC. The  $f_0$ ,  $f_N$  (notch), Q, and various output gains for each mode are shown in Table 4.

### Filter Mode Selection

All operating modes listed in this section can be used with the MAX263/64. The MAX267/68 bandpass filter operates only in Mode 1.

**MODE 1** (Figure 4) is useful when implementing all-pole lowpass and bandpass filters such as Butterworth, Chebyshev, Bessel, etc. It can also be used for notch filters, but only second-order notches because the relative pole and zero locations are fixed. Higher order notch filters require more latitude in  $f_0$  and  $f_N$ , which is why they are more easily implemented with Mode 3A.

# MAX263/MAX264/MAX267/MAX268

## Pin Programmable Universal and Bandpass Filters

Table 4. Filter Modes for Second-Order Functions—MAX263/264 (MAX267/268 = MODE 1, BP only)

MODE	M1, M0	FILTER FUNCTIONS	$f_0$	Q	$f_N$	$H_{OLP}$	$H_{OBP}$	$H_{ON1}$ ( $f \rightarrow 0$ )	$H_{ON2}$ ( $f \rightarrow f_{CLK}/4$ )	OTHER
1	0, 0	LP, BP, N	SEE TABLE 2	SEE TABLE 3	$f_0$	-1	-Q	-1	-1	
2	0, 1	LP, BP, N			$f_0\sqrt{2}$	-0.5	$-Q/\sqrt{2}$	-0.5	-1	
3	1, 0	LP, BP, HP				-1	-Q			$H_{OHP} = -1$
3A	1, 0	LP, BP, HP, N			$f_0\sqrt{\frac{R_H}{R_L}}$	-1	-Q	$+\frac{R_G}{R_L}$	$+\frac{R_G}{R_H}$	$H_{OHP} = -1$
4	1, 1	LP, BP, AP				-2	-2Q			$H_{OAP} = -1$ $f_Z = f_0, Q_Z = Q$

**Notes:**  $f_0$  = Center Frequency  
 $f_N$  = Notch Frequency  
 $H_{OLP}$  = Lowpass Gain at DC  
 $H_{OBP}$  = Bandpass Gain at  $f_0$   
 $H_{OHP}$  = Highpass Gain as  $f$  approaches  $f_{CLK}/4$

$H_{ON1}$  = Notch Gain as  $f$  approaches DC  
 $H_{ON2}$  = Notch Gain as  $f$  approaches  $f_{CLK}/4$   
 $H_{OAP}$  = Allpass Gain  
 $f_Z, Q_Z$  =  $f$  and  $Q$  of Complex Pole Pair

Mode 1, along with Mode 4, supports the highest clock frequencies (see Table 1) because the input summing amplifier is outside the filter's resonant loop (Figure 4). The gain of the lowpass and notch outputs is 1, while the bandpass gain at the center frequency is  $Q$ . For bandpass gains other than  $Q$ , the filter input or output can be scaled by a resistive divider or op amp. In multiple feedback filters, the gain is set by the feedback resistors.

creating a separate notch output. This output allows the notch to be set independently of  $f_0$  by adjusting the op amp's feedback resistor ratio ( $R_H, R_L$ ).  $R_H, R_L$ , and  $R_G$  are external resistors. Because the notch can be independently set, Mode 3A is also useful when designing pole-zero filters such as elliptics.



Figure 4. Filter Mode 1: Second-Order Bandpass, Lowpass and Notch

**MODE 2** (Figure 5) is used for all-pole lowpass and bandpass filters. Key advantages compared to Mode 1 are higher available  $Q$ s (see Table 3) and lower output noise. Mode 2's available  $f_{CLK}/f_0$  ratios are  $\sqrt{2}$  less than with Mode 1 (see Table 2) so a wider overall range of  $f_0$ s can be selected from a single clock when both modes are used together.

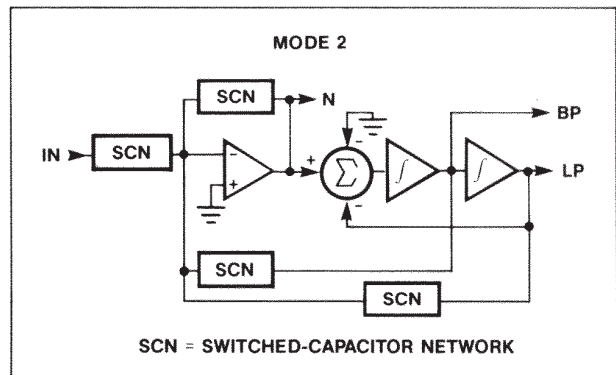

Figure 5. Filter Mode 2: Second-Order Bandpass, Lowpass and Notch

**MODE 3** (Figure 6) is the only mode which produces high-pass filters. The maximum clock frequency is somewhat less than with Mode 1 (see Table 1).



Figure 6. Filter Mode 3: Second-Order Bandpass, Lowpass and Highpass

**MODE 3A** (Figure 7) uses a separate op amp to sum the highpass and lowpass outputs of Mode 3,



# MAX263/MAX264/MAX267/MAX268

## Pin Programmable Universal and Bandpass Filters



Figure 7. Filter Mode 3A: Second-Order Bandpass, Lowpass, Highpass and Notch. For elliptic LP, BP, HP and Notch, the N output is used.

**MODE 4** (Figure 8) is the only mode that provides an allpass output. This is useful when implementing group delay equalization. In addition to this, Mode 4 can also be used in all pole lowpass and bandpass filters. Along with Mode 1, it is the fastest operating mode for the filter, although the gains are different than in Mode 1. When the allpass function is used, note that some amplitude peaking occurs (approximately 0.3dB when  $Q = 8$ ) at  $f_0$ . Also note that  $f_0$  and  $Q$  sampling errors are highest in Mode 4 (see Figure 17).



Figure 8. Filter Mode 4: Second-Order Bandpass, Lowpass and Allpass

### Description of Filter Functions

The MAX263/64 performs all filter functions listed in this section. The MAX267/68 operates only as a bandpass filter.

### BANDPASS (Figure 9)

For all pole bandpass and lowpass filters (Butterworth, Bessel, Chebyshev) use Mode 1 if possible. If appropriate  $f_{CLK}/f_0$  or  $Q$  values are not available in Mode 1, Mode 2 may provide a selection that is closer to the required values. Mode 1 however has the highest bandwidth (see Table 1). For pole-zero filters such as elliptics see Mode 3A.

$$G(s) = H_{OBP} \frac{s(\omega_0/Q)}{s^2 + s(\omega_0/Q) + \omega_0^2}$$

$H_{OBP}$  = Bandpass output gain at  $\omega = \omega_0$

$f_0 = \omega_0/2\pi$  = The center frequency of the complex pole pair. Input-output phase shift is  $-180^\circ$  at  $f_0$ .

$Q$  = The quality factor of the complex pole pair. Also the ratio of  $f_0$  to  $-3\text{dB}$  bandwidth of the second-order bandpass response.

### LOWPASS See Bandpass text. (Figure 10)

$$G(s) = H_{OLP} \frac{\omega_0^2}{s^2 + s(\omega_0/Q) + \omega_0^2}$$

$H_{OLP}$  = Lowpass output gain at DC

$f_0 = \omega_0/2\pi$

### HIGHPASS (Figure 11)

Mode 3 is the only mode with a highpass output. It will work for all pole filter types such as Butterworth, Bessel and Chebyshev. Use mode 3A for filters employing both poles and zeros such as elliptics.

$$G(s) = H_{OHP} \frac{s^2}{s^2 + s(\omega_0/Q) + \omega_0^2}$$

$H_{OHP}$  = Highpass output gain as  $f$  approaches  $f_{CLK}/4$

$f_0 = \omega_0/2\pi$



Figure 9. Second-Order Bandpass Characteristics

# MAX263/MAX264/MAX267/MAX268

## Pin Programmable Universal and Bandpass Filters



Figure 10. Second-Order Lowpass Characteristics



Figure 11. Second-Order Highpass Characteristics

### NOTCH (Figure 12)

Mode 3A is recommended for multi-pole notch filters. In 2nd order filters, Mode 1 can also be used. The advantages of Mode 1 are higher bandwidth compared

to mode 3 (Higher  $f_N$  can be implemented) and no need for external components as required in Mode 3A.

$$G(s) = H_{ON2} \frac{s^2 + \omega_n^2}{s^2 + s(\omega_0/Q) + \omega_0^2}$$

$H_{ON2}$  = Notch output gain as  $f$  approaches  $f_{CLK}/4$

$H_{ON1}$  = Notch output gain as  $f$  approaches DC

$$f_n = \omega_n/2\pi$$



Figure 12. Second-Order Notch Characteristics

### ALL PASS

Mode 4 is the only configuration in which an allpass function can be realized.

$$G(s) = H_{OAP} \frac{s^2 - s(\omega_0/Q) + \omega_0^2}{s^2 + s(\omega_0/Q) + \omega_0^2}$$

$H_{OAP}$  = All pass output gain for  $DC < f < f_{CLK}/4$

$$f_0 = \omega_0/2\pi$$

### Filter Design Procedure

The procedure for most filter designs is to first convert the required frequency response specifications to  $f_0$ s and  $Q$ s for the appropriate number of second-order sections that implement the filter. This can be done by using design equations or tables in available literature, or can be conveniently calculated using Maxim's filter design software. Once the  $f_0$  and  $Q$ s have been found, the next step is to turn them into the digital program coefficients required by the filter. An operating Mode and clock frequency (or clock/center frequency ratio) must also be selected.

Next, if the sample rate ( $f_{CLK}/2$ ) is low enough to cause significant errors, the selected  $f_0$ s and  $Q$ s should be corrected to account for sampling effects by using Figure 17 or Maxim's design software. In most cases, the sampling errors are small enough to require no correction, i.e. less than 1%. In any case, with or without correction, the required  $f_0$ s and  $Q$ s can then be selected from Tables 2 and 3. Maxim's filter design software can also perform this last step. The desired  $f_0$ s and  $Q$ s are stated, and the appropriate digital coefficients are supplied.

# MAX263/MAX264/MAX267/MAX268

## Pin Programmable Universal and Bandpass Filters

### Multiple Feedback Bandpass Filters

An alternate implementation of all-pole bandpass filters (i.e. Butterworth, Chebyshev) requires only one clock and common programming for all second-order sections. This can be useful with MAX26X pin-programmed filters since the two second-order halves must be programmed with the same  $f_{CLK}/f_0$  ratio and Q (although they may use different clocks).

As shown in Figure 13, external resistors connect the outputs of cascaded filter sections to a summing op-amp at the input. Since each 2nd-order section inverts (gain = -Q) the output from odd numbered sections (except for the first) must be inverted before being fed back as in the 8th-order example in Figure 13. The MAX267/68 has an on-chip amplifier for this purpose but the MAX263/64 requires external op-amp(s).

In multiple feedback filters, the bandpass response is a function of the clock,  $f_{CLK}/f_0$  ratio, Q, and feedback resistor ratios. In Table 5, constants for calculating resistor ratios in common bandpass configurations are listed. Maxim's filter design program "BP" also selects resistors for multiple feedback bandpass designs. A 4th-order design example (Figure 13) best illustrates how Table 5 is used.

### Multiple Feedback Example

Requirements: 4th-order Chebyshev with 1 dB pass-band ripple,  $f_0 = 10\text{kHz}$ , and bandwidth (BW) = 2kHz.

1) The overall filter Q is  $Q_F = f_0/BW = 10\text{kHz}/2\text{kHz} = 5$

2) From Table 5:  $K_Q = 1.8219$

3) The Q of each 2nd-order section is  $Q_R = Q_F \times K_Q = 5 \times 1.8219 = 9.09$

4)  $R_F$  is selected, 10k $\Omega$  is a convenient value.

5)  $R_2 = K_2 R_F (Q_R/2)^2 = 1.5039 \times 10\text{k} \times (9.109/2)^2 = 312\text{k}$

In higher order filters, the general equation is:  
 $R_N = K_N R_F (Q_R/2)^N$

6)  $R_0$  sets the overall gain, A:  $R_0 = K_0 R_F (Q_R/2)^2/A$ , so for a gain of 1:  $R_0 = 1.0930 \times 10\text{k} \times (9.109/2)^2/1 = 226.8\text{k}$ . In higher order filters the general equation is  $R_0 = K_0 R_F (Q_R/2)^M$  where M = (order of filter)/2.

7) The filter  $f_0$  can be programmed using a wide range of clock frequencies and  $f_{CLK}/f_0$  ratios. If  $f_{CLK} = 1\text{MHz}$ , then  $f_{CLK}/f_0 = 100$  (code 00000 = 100.53) results in  $f_0 = 10\text{kHz}$ .

8) A 2.5pF to 10pF capacitor may be required across  $R_2$  to prevent response peaking.

### Cascading Filters

In some designs, such as very narrow band filters, several second-order sections with identical center frequency may be cascaded without multiple feedback. The total Q of the resultant filter is:

$$\text{Total } Q_T = \frac{Q}{\sqrt{(2^{1/N} - 1)}}$$

Q is the Q of each individual filter section, and N is the number of sections. In Table 6, the Total Q and

Table 5. Multiple Feedback Bandpass Filter Constants

TYPE (RIPPLE)	ORDER	K0	K2	K3	K4	KQ
Butterworth (3.0 dB)	4	2.0000	4.0000			1.4142
	6	2.3704	2.6667	9.1429		1.5000
	8	2.9142	2.000	5.8284	14.315	1.5307
Chebyshev (0.1 dB)	4	1.6983	2.9512			0.8430
	6	1.3183	1.2137	4.5125		1.5473
	8	0.7986	0.5782	1.8809	2.0343	2.2176
Chebyshev (0.2 dB)	4	1.5757	2.5998			1.0378
	6	1.1128	0.9894	3.7271		1.8413
	8	0.5891	0.4551	1.4954	1.3309	2.6057
Chebyshev (0.5 dB)	4	1.3405	2.0161			1.4029
	6	0.8143	0.6897	2.6447		2.3944
	8	0.3389	0.3040	1.0114	0.6365	3.3406
Chebyshev (1.0 dB)	4	1.0930	1.5039			1.8219
	6	0.5822	0.4756	1.8475		3.0354
	8	0.1869	0.2038	0.6840	0.3002	4.1981
Chebyshev (1.5 dB)	4	0.9192	1.1934			2.1688
	6	0.4515	0.3616	1.4145		3.5705
Chebyshev (2.0 dB)	4	0.7850	0.9767			2.4881
	6	0.3641	0.2878	1.1308		4.0660
Chebyshev (2.5 dB)	4	0.6769	0.8148			2.7962
	6	0.3005	0.2353	0.9275		4.5462
Chebyshev (3.0 dB)	4	0.5875	0.6886			3.1013
	6	0.2519	0.1959	0.7739		5.0231

# MAX263/MAX264/MAX267/MAX268

## Pin Programmable Universal and Bandpass Filters

**Table 6. Cascading Identical Bandpass Filter Sections**

Total Sections	Total B.W.	Total Q
1	1.000 B	1.00 Q
2	0.644 B	1.55 Q
3	0.510 B	1.96 Q
4	0.435 B	2.30 Q
5	0.386 B	2.60 Q

**Note:** B = individual stage bandwidth, Q = individual stage Q. bandwidth are listed for up to five identical second-order sections. B is the bandwidth of each section.

In high order bandpass filters that do not use multiple feedback, stages with different  $f_0$ s and Qs may also be cascaded. When this happens the overall filter gain at the bandpass center frequency is not simply the product of the individual gains because  $f_0$ s, the frequency where each section's gain is specified, is different for each second-order section. The gain of each section at the cascaded filter's center frequency must be determined to obtain the total gain.

For all-pole filters the gain,  $H(f_0)$ , at each second-order section's  $f_0$  is divided by an adjustment factor, G, to obtain that section's gain,  $H(f_{0BP})$ , at the overall center frequency:

$$H_1(f_{0BP}) = H(f_{01})/G_1 = \text{Section 1's Gain at } f_{0BP}$$

$$G_1 = \frac{Q_1[(F_1^2 - 1)^2 + (F_1/Q_1)^2]^{1/2}}{F_1}$$

where  $F_1 = f_{01}/f_{0BP}$

$G_1$ ,  $Q_1$ , and  $f_{01}$  are the gain adjustment factor, Q, and  $f_0$  for the first of the cascaded second-order sections. The gain of the other sections (2, 3 etc.) at  $f_{0BP}$  is determined the same way. The overall gain is:

$$H(f_{0BP}) = H_1(f_{0BP}) \times H_2(f_{0BP}) \times \text{etc.}$$

For cascaded filters with zeros ( $f_z$ ) such as elliptics, the gain adjustment factor for each stage is:

$$G_1 = \frac{Q_1[F_{Z1}^2 - F_1^2][(F_1^2 - 1)^2 + (F_1/Q_1)^2]^{1/2}}{F_1^2(F_{Z1}^2 - 1)}$$

where  $F_{Z1} = f_{z1}/f_{0BP}$ , and  $F_1$  is the same as above.

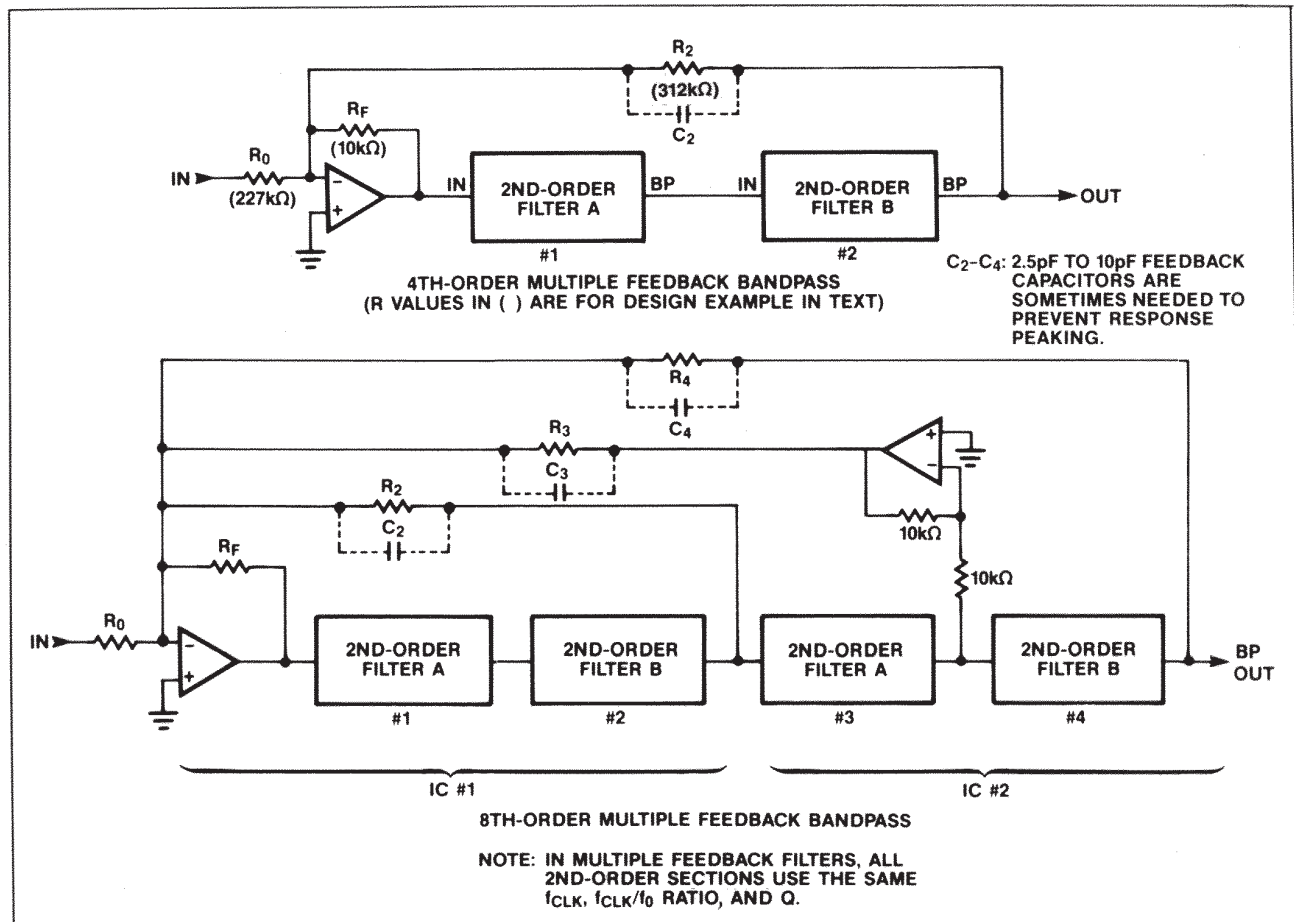

Figure 13. Multiple Feedback Bandpass Block Diagram (See Text for R Values)



# MAX263/MAX264/MAX267/MAX268

## Pin Programmable Universal and Bandpass Filters

### Application Hints

#### Power Supplies

The MAX263/64/67/68 can be operated with a variety of power supply configurations including +5V to +12V single supply, or  $\pm 2.5V$  to  $\pm 6V$  dual supplies. When a single supply is used,  $V^-$  is connected to system ground and the filter's GND pin should be biased at  $V^+/2$ . The input signal is then either capacitively coupled to the filter input or biased to  $V^+/2$ . Figure 14 shows circuit connections for single supply operation.

Power consumption at  $\pm 5V$  is reduced if  $CLK_A$  and  $CLK_B$  are driven with  $\pm 5V$ , rather than TTL or 0 to 5V levels. Operation with +5V or  $\pm 2.5V$  power lowers power consumption but also reduces bandwidth by approximately 25% compared to +12V or  $\pm 5V$  supplies.

Best performance is achieved if  $V^+$  and  $V^-$  are bypassed to ground with  $4.7\mu F$  electrolytic (Tantalum is preferred.) and  $0.1\mu F$  ceramic capacitors. These should be located as close to the supply pins as possible. The lead length of the bypass capacitors should be shortest at the  $V^+$  and  $V^-$  pins. When using a single supply  $V^+$  and GND should be bypassed to  $V^-$  as shown in Figure 14.

#### Output Swing and Clipping

MAX26X outputs are designed to swing to within 0.15V of each supply rail with a  $10k\Omega$  load.

To ensure that the outputs are not driven beyond their maximum range (output clipping), the peak amplitude response, individual section gains ( $H_{OHP}$ ,  $H_{OLP}$ ,  $H_{OHP}$ ), input signal level, and filter offset voltages must be carefully considered. It is especially important to check UNUSED outputs for clipping (i.e. the lowpass output in a bandpass hookup) because overload at ANY filter stage severely distorts the overall response. The maximum signal swing with  $\pm 4.75V$  supplies and a 1.0V filter offset is approximately  $\pm 3.5V$ .

For example let's assume a fourth-order lowpass filter is being implemented with a Q of 2 using Mode 1. With a single 5V supply (i.e.  $\pm 2.5V$  with respect to chip GND) the maximum output signal is  $\pm 2V$  (w.r.t. GND). Since in Mode 1 the maximum signal is Q times the input signal, the input should not exceed  $\pm(2/Q)V$ , or  $\pm 1V$  in this case.



Figure 14. Power Supply and Input Connections for Single Supply Operation

# MAX263/MAX264/MAX267/MAX268

## Pin Programmable Universal and Bandpass Filters



Figure 15. MAX263 Bandpass Output Clock Noise

### Clock Feedthrough and Noise

Typical wideband noise for MAX26X series devices is  $0.5\text{mV}_{\text{pp}}$  from DC to 100kHz. The noise is virtually independent of clock frequency. In multistage filters, the section with the highest Q should be placed first for lower output noise.

The output waveform of the MAX26X series and other switched capacitor filters appears as a sampled signal with stepping or “staircasing” of the output waveform occurring at the internal sample rate ( $f_{\text{CLK}}/2$ ). This stepping, if objectionable, can be removed by adding a single pole RC filter. With no input signal, clock related feedthrough is approximately  $8\text{mV}_{\text{pp}}$ . This can also be attenuated with an RC smoothing filter as shown with the MAX263 in Figure 15.

### Input Impedance

The filter input model is shown in Figure 16. Input capacitor  $C_A$  is shunted by  $C_B$  which is switched at one half the input clock frequency ( $f_{\text{CLK}}/2$ ). The input impedance is described by:  $R_{\text{IN}} = 2/(C_A \times f_{\text{CLK}})$ . There is also a fixed stray capacitance of about 5pF to ground.

### Digital Inputs

Filter programming is accomplished by tying input pins M0, M1, F0-F4, and Q0-Q6 to high or low voltage levels, typically  $V^+$  and  $V^-$ . Inputs are not internally pulled up or down, so these inputs must not be left unconnected. Input thresholds are guaranteed to be no higher than  $V^+ - 0.5\text{V}$  and no lower than  $V^- + 0.5\text{V}$ . When driving the digital inputs (i.e., the digital inputs



Figure 16. MAX263/64/67/68 Input Model

are tied to microprocessor I/O lines), additional protection is provided by placing a  $1\text{k}\Omega$  resistor in series with the programming pins. If pull-up resistors are used with switches at the programming inputs, as might be the case in prototype breadboards, the pull-up resistors should be no more than  $3.3\text{k}\Omega$ .

### $f_0$ and Q at Low Sample Rates

When low  $f_{\text{CLK}}/f_0$  ratios and low Q settings are selected, deviation from ideal continuous filter response may be noticeable in some designs. This is due to interaction between Q, and  $f_0$  at low  $f_{\text{CLK}}/f_0$  ratios and Qs. The data in Figure 17 quantifies these differences. Since the errors are predictable, the graphs can be used to correct the selected  $f_0$  and Q so that the actual realized parameters are on target. These predicted errors are not unique to MAX26X series devices and in fact occur with all sampled filters. Consequently, these corrections can be applied to other switched-capacitor filters. In the majority of cases, the errors are not significant, i.e. less than 1%, and correction is not needed. However, the MAX264/68 does employ a lower range of  $f_{\text{CLK}}/f_0$  ratios than the MAX263/67 and is more prone to sampling errors as the tables show.

Maxim’s filter design software applies the previous corrections automatically as a function of desired  $f_{\text{CLK}}/f_0$ , and Q. Therefore, Figure 17 should NOT be used when Maxim’s software determines  $f_0$  and Q. This results in overcompensation of the sampling errors since the correction factors are then counted twice.

The data plotted in Figure 17 applies for Modes 1 and 3. When using Figure 17 for Mode 4, the  $f_0$  error obtained from the graph should be multiplied by 1.5 and the Q error should be multiplied by 3.0. In Mode 2 the value of  $f_{\text{CLK}}/f_0$  should be multiplied by  $\sqrt{2}$  and the programmed Q should be divided by  $\sqrt{2}$  before using the graphs.

# MAX263/MAX264/MAX267/MAX268

## Pin Programmable Universal and Bandpass Filters



Figure 17. Sampling Errors in  $f_{CLK}/f_0$  and Q at Low  $f_{CLK}/f_0$  and Q Settings

### Aliasing

As with all sampled systems, frequency components of the input signal above one half the sampling rate will be aliased. In particular, input signal components near the sampling rate generate difference frequencies that often fall within the passband of the filter. Such aliased signals, when they appear at the output, are indistinguishable from real input information. For example, the aliased output signal generated when a 99kHz waveform is applied to a filter sampling at 100kHz, ( $f_{CLK} = 200\text{kHz}$ ) is 1kHz. This waveform is an attenuated version of the output that would result from a true 1kHz input. Remember that with the MAX26X series filters, the nyquist rate (one half the sample rate) is in fact  $f_{CLK}/4$  because  $f_{CLK}$  is internally divided by two.

A simple passive RC lowpass input filter is usually sufficient to remove input frequencies that can cause aliasing. In many cases the input signal itself may be band limited and require no special anti-alias filtering. The wideband MAX264/68 uses lower  $f_{CLK}/f_0$  ratios than the MAX263/67 and for this reason is more likely to require input filtering than the MAX263 or MAX267.

### Trimming DC Offset

The DC offset voltage at the LP or Notch output can be adjusted with the circuit in Figure 18. This circuit also uses the input op-amp to implement a single pole anti-alias filter. Note that the total offset will generally be less in multistage filters than when only one section is used since each offset is typically negative and each section inverts. When the HP or BP outputs are used, the offset can be removed with capacitor coupling.



Figure 18. Circuit for DC Offset Adjustment

## Design Examples

### 4th-Order Multiple Feedback Bandpass—MAX268

In Figure 19, a pin-programmed MAX268 operates as a 4th-order 50kHz Chebyshev bandpass. The specifications are:

- Center frequency ( $f_0$ ) = 50kHz
- Pass bandwidth = 10kHz
- Max. passband ripple = 0.1dB
- Gain at center freq. = 1V/V

Two identical 2nd-order sections and the internal op amp are used with multiple feedback. The general form is as in Figure 13. Maxim's design program, BP, generates the programming codes and feedback resistor values. With a 2.5MHz crystal clock the realized parameters are:

- Center frequency = 50.305kHz
- Pass Bandwidth = 10.07kHz
- Programmed  $f_{CLK}/f_0$  ratio = 50.27 (N = 3)
- Programmed Q = 4.27 (N = 113)
- (desired Q = 4.215)
- Actual Q (with error correction) = 4.21
- Resistors:  $R_2 = 131\text{k}\Omega$ ,  $R_0 = 75\text{k}\Omega$ ,  $R_F = 10\text{k}\Omega$



# MAX263/MAX264/MAX267/MAX268

## Pin Programmable Universal and Bandpass Filters



Figure 19. 4th-Order 50kHz Chebyshev Bandpass Using Multiple Feedback

Other clock rates and  $f_{CLK}/f_0$  ratios can be chosen to implement the same filter, but larger  $f_{CLK}/f_0$  ratios provide performance closer to the ideal. Capacitor  $C_2$  may be needed to prevent response peaking at the passband edge. In this example  $C_2 = 2.5\text{pF}$ .

Multiple feedback can also be extended to 8th-order designs while still using one clock by adding a second MAX268 and 2 additional feedback resistors. These can also be calculated with the design program, BP. Note that for filter order above 4, the feedback signal from odd filter sections is inverted before it is summed (see Figure 13).



Figure 20. 4th-Order 50kHz Chebyshev Bandpass Using No External Resistors

### 4th-Order Bandpass (No Multiple Feedback)—MAX268

Without multiple feedback, the previous example can be implemented with no external components, however separate clocks are required for  $CLK_A$  and  $CLK_B$  (Figure 20). The target specifications are the same as before. The realized parameters are now:

- $CLK_A = 1.89\text{MHz}$ ,  $CLK_B = 2.5\text{MHz}$
- Center frequency = 50kHz
- Pass bandwidth = 10kHz
- Programmed  $f_{CLK}/f_0$  ratio = 43.98 ( $N = 1$ )
- Programmed  $Q = 4.27$  ( $N = 113$ ) (desired  $Q = 4.215$ )
- Actual  $Q$  (with error correction) = 4.2

With the chosen  $f_{CLK}/f_0$  ratio, a crystal may be used at  $CLK_A$  while a divided system clock, if available (2.5, 5, 10, or 20MHz), drives  $CLK_B$ . This is suggested because  $CLK_A$  has internal circuitry to drive a crystal while  $CLK_B$  does not. Other clock sources may be used with a different programmed  $f_{CLK}/f_0$  as long as the ratio between  $CLK_A$  and  $CLK_B$  remains the same as above. Another advantage of this circuit is that higher center frequencies can be achieved relative to equivalent multiple feedback designs because lower  $Q$  sections are used compared to multiple feedback.



# MAX263/MAX264/MAX267/MAX268

## Pin Programmable Universal and Bandpass Filters



Figure 21. Dual Tracking 3kHz 4th-Order Lowpass

### Dual 4th-Order Tracking Lowpass—MAX263

In Figure 21, two Butterworth lowpass filters are set up to accurately track each other. By “splitting” two MAX263s only one clock is needed. The specifications are:

$$\begin{aligned} \text{Cutoff frequency} &= 3\text{kHz} \\ f_{0A} = f_{0B} &= 3\text{kHz} \\ Q_A = 1.307, Q_B &= 0.541 \end{aligned}$$

These values can be programmed directly into the filter. However, since the Qs are low, sampling errors may be large enough to deserve attention. From Figure 17, if  $f_{\text{CLK}}/f_0$  is near 130 ( $f_{\text{CLK}}$  is 400kHz),  $f_{0A}$  and  $f_{0B}$  will be about 4% and 1.5% high respectively.  $Q_A$  and  $Q_B$  will be 1.2% and 0.5% low. These errors may not be large enough to worry about but are corrected here (within the programming resolution of the MAX263)

by the filter design programs PZ and MPP.  $f_{0A}$  and  $f_{0B}$  are programmed to different values ( $N_A = 11$ ,  $N_B = 12$ ) for this reason.

$$\begin{aligned} \text{Mode 1, } \text{CLK}_A = \text{CLK}_B &= 400\text{kHz} \\ f_{\text{CLK}}/f_{0A} &= 135.08, N = 11 \\ &(\text{target } f_{0A} = 2961\text{Hz, actual} = 3008\text{Hz}) \\ f_{\text{CLK}}/f_{0B} &= 138.23, N = 12 \\ &(\text{target } f_{0B} = 2894\text{Hz, actual} = 3015\text{Hz}) \\ Q_A = 1.31, N = 79 &(\text{actual } Q_A = 1.30) \\ Q_B = 0.547, N = 11 &(\text{actual } Q_B = 0.542) \end{aligned}$$

# MAX263/MAX264/MAX267/MAX268

## Pin Programmable Universal and Bandpass Filters

### Ordering Information (continued)

### Chip Topography

PART	TEMP. RANGE	PACKAGE*	ACCURACY
MAX264AEPI	-40°C to +85°C	Plastic DIP	1%
MAX264BEPI	-40°C to +85°C	Plastic DIP	2%
MAX264ACWI	0°C to +70°C	Wide SO	1%
MAX264BCWI	0°C to +70°C	Wide SO	2%
MAX264AMJI	-55°C to +125°C	CERDIP	1%
MAX264MBJI	-55°C to +125°C	CERDIP	2%
MAX267ACNG	0°C to +70°C	Plastic DIP	1%
MAX267BCNG	0°C to +70°C	Plastic DIP	2%
MAX267AENG	-40°C to +85°C	Plastic DIP	1%
MAX267BENG	-40°C to +85°C	Plastic DIP	2%
MAX267ACWG	0°C to +70°C	Wide SO	1%
MAX267BCWG	0°C to +70°C	Wide SO	2%
MAX267AMRG	-55°C to +125°C	CERDIP	1%
MAX267BMRG	-55°C to +125°C	CERDIP	2%
MAX268ACNG	0°C to +70°C	Plastic DIP	1%
MAX268BCNG	0°C to +70°C	Plastic DIP	2%
MAX268AENG	-40°C to +85°C	Plastic DIP	1%
MAX268BENG	-40°C to +85°C	Plastic DIP	2%
MAX268ACWG	0°C to +70°C	Wide SO	1%
MAX268BCWG	0°C to +70°C	Wide SO	2%
MAX268AMRG	-55°C to +125°C	CERDIP	1%
MAX268BMRG	-55°C to +125°C	CERDIP	2%

\* MAX263/264 packages are 28-pin 0.6" wide DIP and 28-pin 0.3" wide SO (Small Outline).

MAX267/268 packages are 24-pin 0.3" narrow DIP and 24-pin 0.3" wide SO (Small Outline).



NOTE: LABELS IN PARENTHESES ( ) ARE FOR MAX 267/268 ONLY

# MAX263/MAX264/MAX267/MAX268

## Pin Programmable Universal and Bandwidth Filters

### Package Information

(The package drawing(s) in this data sheet may not reflect the most current specifications. For the latest package outline information go to [www.maxim-ic.com/packages](http://www.maxim-ic.com/packages).)



# MAX263/MAX264/MAX267/MAX268

## Pin Programmable Universal and Bandwidth Filters

### Package Information (continued)

(The package drawing(s) in this data sheet may not reflect the most current specifications. For the latest package outline information go to [www.maxim-ic.com/packages](http://www.maxim-ic.com/packages).)



TOP VIEW



FRONT VIEW



SIDE VIEW

DIM	INCHES		MILLIMETERS	
	MIN	MAX	MIN	MAX
A	-	0.200	-	5.08
A1	0.015	-	0.39	-
A2	0.125	0.175	3.18	4.45
A3	0.055	0.080	1.40	2.03
B	0.016	0.020	0.41	0.51
B1	0.045	0.065	1.14	1.65
C	0.008	0.012	0.21	0.30
D1	0.005	0.009	0.13	0.22
E	0.600	0.625	15.24	15.87
E1	0.525	0.575	13.34	14.61
e	0.100 BSC		2.54 BSC	
eA	0.600 BSC		15.24 BSC	
eB	-	0.700	-	17.78
L	0.120	0.150	3.05	3.81

VARIATIONS:

DIM	INCHES		MILLIMETERS		N	MS011
	MIN	MAX	MIN	MAX		
D	1.230	1.270	31.24	32.26	24	AA
D	1.430	1.470	36.32	37.34	28	AB
D	2.025	2.075	51.44	52.71	40	AC

**NOTES:**

1. D&E DO NOT INCLUDE MOLD FLASH.
2. MOLD FLASH OR PROTRUSIONS NOT TO EXCEED 0.15mm (.006").
3. CONTROLLING DIMENSION: MILLIMETERS.
4. MEETS JEDEC MS011.
5. N = NUMBER OF PINS.

PROPRIETARY INFORMATION

TITLE:  
PACKAGE OUTLINE, .600" PDIP

APPROVAL	DOCUMENT CONTROL NO. 21-0044	REV. B	1/1
----------	---------------------------------	-----------	-----

PDIPWEP5



# MAX263/MAX264/MAX267/MAX268

## Pin Programmable Universal and Bandwidth Filters

### Package Information (continued)

(The package drawing(s) in this data sheet may not reflect the most current specifications. For the latest package outline information go to [www.maxim-ic.com/packages](http://www.maxim-ic.com/packages).)



SOICWEPs

# MAX263/MAX264/MAX267/MAX268

## Pin Programmable Universal and Bandwidth Filters

### Package Information (continued)

(The package drawing(s) in this data sheet may not reflect the most current specifications. For the latest package outline information go to [www.maxim-ic.com/packages](http://www.maxim-ic.com/packages).)



TOP VIEW



FRONT VIEW



SIDE VIEW

**NOTES:**  
 1. D&E DO NOT INCLUDE MOLD FLASH.  
 2. MOLD FLASH OR PROTRUSIONS NOT TO EXCEED 0.15mm (.006").  
 3. LEADS TO BE COPLANAR WITHIN 0.10mm (.004").  
 4. CONTROLLING DIMENSION: MILLIMETERS.  
 5. MEETS JEDEC MS013.  
 6. N = NUMBER OF PINS.

DIM	INCHES		MILLIMETERS	
	MIN	MAX	MIN	MAX
A	0.093	0.104	2.35	2.65
A1	0.004	0.012	0.10	0.30
B	0.014	0.019	0.35	0.49
C	0.009	0.013	0.23	0.32
e	0.050		1.27	
E	0.291	0.299	7.40	7.60
H	0.394	0.419	10.00	10.65
L	0.016	0.050	0.40	1.27

VARIATIONS:

DIM	INCHES		MILLIMETERS		N	MS013
	MIN	MAX	MIN	MAX		
D	0.398	0.413	10.10	10.50	16	AA
D	0.447	0.463	11.35	11.75	18	AB
D	0.496	0.512	12.60	13.00	20	AC
D	0.598	0.614	15.20	15.60	24	AD
D	0.697	0.713	17.70	18.10	28	AE

SOICWEP5

PROPRIETARY INFORMATION			
TITLE: <b>PACKAGE OUTLINE, .300" SOIC</b>			
APPROVAL	DOCUMENT CONTROL NO. <b>21-0042</b>	REV.	<b>B</b> 1/1

# MAX263/MAX264/MAX267/MAX268

## Pin Programmable Universal and Bandwidth Filters

### Package Information (continued)

(The package drawing(s) in this data sheet may not reflect the most current specifications. For the latest package outline information go to [www.maxim-ic.com/packages](http://www.maxim-ic.com/packages).)



# MAX263/MAX264/MAX267/MAX268

## Pin Programmable Universal and Bandwidth Filters

### Revision History

REVISION NUMBER	REVISION DATE	DESCRIPTION	PAGES CHANGED
4	12/07	Removed information related to available design software	1, 6, 7, 24



Maxim cannot assume responsibility for use of any circuitry other than circuitry entirely embodied in a Maxim product. No circuit patent licenses are implied. Maxim reserves the right to change the circuitry and specifications without notice at any time. The parametric values (min and max limits) shown in the Electrical Characteristics table are guaranteed. Other parametric values quoted in this data sheet are provided for guidance.





Компания «ЭлектроПласт» предлагает заключение долгосрочных отношений при поставках импортных электронных компонентов на взаимовыгодных условиях!

Наши преимущества:

- Оперативные поставки широкого спектра электронных компонентов отечественного и импортного производства напрямую от производителей и с крупнейших мировых складов;
- Поставка более 17-ти миллионов наименований электронных компонентов;
- Поставка сложных, дефицитных, либо снятых с производства позиций;
- Оперативные сроки поставки под заказ (от 5 рабочих дней);
- Экспресс доставка в любую точку России;
- Техническая поддержка проекта, помощь в подборе аналогов, поставка прототипов;
- Система менеджмента качества сертифицирована по Международному стандарту ISO 9001;
- Лицензия ФСБ на осуществление работ с использованием сведений, составляющих государственную тайну;
- Поставка специализированных компонентов (Xilinx, Altera, Analog Devices, Intersil, Interpoint, Microsemi, Aeroflex, Peregrine, Syfer, Eurofarad, Texas Instrument, Miteq, Cobham, E2V, MA-COM, Hittite, Mini-Circuits, General Dynamics и др.);

Помимо этого, одним из направлений компании «ЭлектроПласт» является направление «Источники питания». Мы предлагаем Вам помощь Конструкторского отдела:

- Подбор оптимального решения, техническое обоснование при выборе компонента;
- Подбор аналогов;
- Консультации по применению компонента;
- Поставка образцов и прототипов;
- Техническая поддержка проекта;
- Защита от снятия компонента с производства.



#### Как с нами связаться

**Телефон:** 8 (812) 309 58 32 (многоканальный)

**Факс:** 8 (812) 320-02-42

**Электронная почта:** [org@eplast1.ru](mailto:org@eplast1.ru)

**Адрес:** 198099, г. Санкт-Петербург, ул. Калинина, дом 2, корпус 4, литера А.