

NCV898032

2 MHz Automotive Grade Non-Synchronous Boost Controller

The NCV898032 is an adjustable output non-synchronous boost controller which drives an external N-channel MOSFET. The device uses peak current mode control with internal slope compensation. The IC incorporates an internal regulator that supplies charge to the gate driver.

Protection features include internally-set soft-start, undervoltage lockout, cycle-by-cycle current limiting and thermal shutdown.

Additional features include low quiescent current sleep mode and microprocessor compatible input pin.

Features

- Peak Current Mode Control with Internal Slope Compensation
- 0.2 V \pm 3% Reference Voltage for Constant Current Loads
- 2 MHz Fixed Frequency Operation
- Wide Input Voltage Range of 3.2 V to 40 V, 45 V Load Dump
- Input Undervoltage Lockout (UVLO)
- Internal Soft-Start
- Low Quiescent Current in Sleep Mode (< 10 μ A Typical)
- Cycle-by-Cycle Current Limit Protection
- Hiccup-Mode Overcurrent Protection (OCP)
- Thermal Shutdown (TSD)
- NCV Prefix for Automotive and Other Applications Requiring Unique Site and Control Change Requirements; AEC-Q100 Qualified and PPAP Capable
- These Devices are Pb-Free, Halogen Free/BFR Free and are RoHS Compliant

Typical Applications

- LED Lighting
- Headlamps
- Backlighting



ON Semiconductor®

www.onsemi.com



8980xx = Specific Device Code
xx = 32
A = Assembly Location
L = Wafer Lot
Y = Year
W = Work Week
▪ = Pb-Free Package

PIN CONNECTIONS

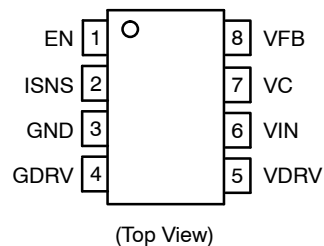

ORDERING INFORMATION

Device	Package	Shipping†
NCV898032D1R2G	SOIC-8 (Pb-Free)	2500 / Tape & Reel

†For information on tape and reel specifications, including part orientation and tape sizes, please refer to our Tape and Reel Packaging Specification Brochure, BRD8011/D.

NCV898032

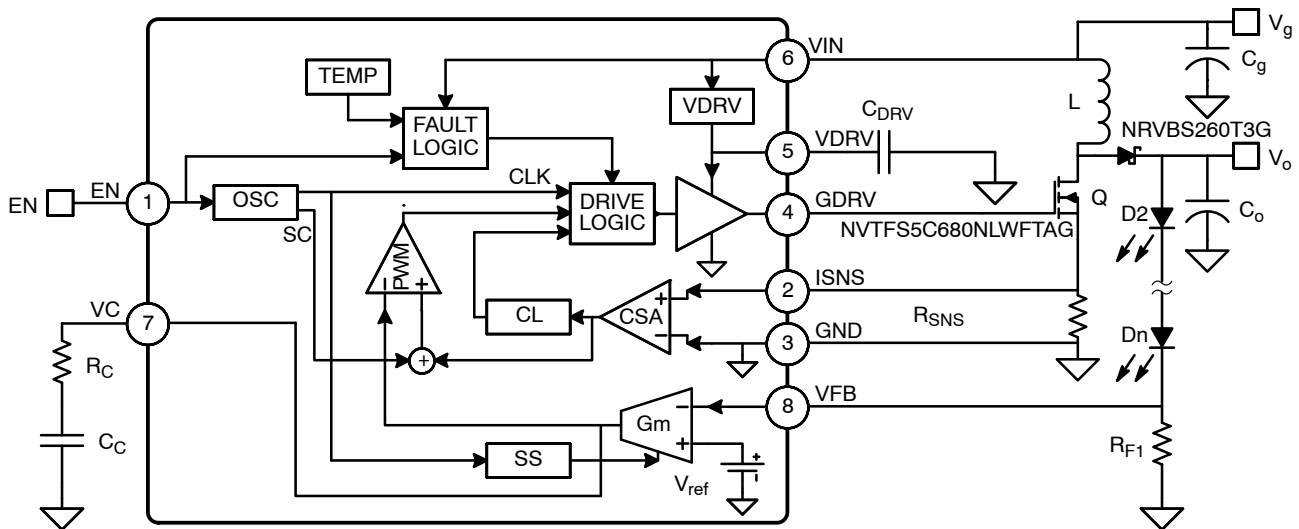

Figure 1. Simplified Block Diagram and Application Schematic

PACKAGE PIN DESCRIPTIONS

Pin No.	Pin Symbol	Function
1	EN	Enable input. The part is disabled into sleep mode when this pin is brought low for longer than the enable time-out period.
2	ISNS	Current sense input. Connect this pin to the source of the external N-MOSFET, through a current-sense resistor to ground to sense the switching current for regulation and current limiting.
3	GND	Ground reference.
4	GDRV	Gate driver output. Connect to gate of the external N-MOSFET. A series resistance can be added from GDRV to the gate to tailor EMC performance in addition to the internal.
5	VDRV	Driving voltage. Internally-regulated supply for driving the external N-MOSFET, sourced from VIN. Bypass with a 1.0 μ F ceramic capacitor to ground.
6	VIN	Input voltage. If bootstrapping operation is desired, connect a diode from the input supply to VIN, in addition to a diode from the output voltage to VDRV and/or VIN.
7	VC	Output of the voltage error amplifier. An external compensator network from VC to GND is used to stabilize the converter.
8	VFB	Output voltage feedback. A resistor from the output voltage to VFB with another resistor from VFB to GND creates a voltage divider for regulation and programming of the output voltage.

NCV898032

ABSOLUTE MAXIMUM RATINGS (Voltages are with respect to GND, unless otherwise indicated)

Rating	Value	Unit
Dc Supply Voltage (VIN)	-0.3 to 40	V
Peak Transient Voltage (Load Dump on VIN)	45	V
Dc Supply Voltage (VDRV, GDRV)	12	V
Peak Transient Voltage (VFB)	-0.3 to 6	V
Dc Voltage (VC, VFB, ISNS)	-0.3 to 3.6	V
Dc Voltage (EN)	-0.3 to 6	V
Dc Voltage Stress (VIN - VDRV)*	-0.7 to 40	V
Operating Junction Temperature	-40 to 150	°C
Storage Temperature Range	-65 to 150	°C
Peak Reflow Soldering Temperature: Pb-Free, 60 to 150 seconds at 217°C	265 peak	°C

Stresses exceeding those listed in the Maximum Ratings table may damage the device. If any of these limits are exceeded, device functionality should not be assumed, damage may occur and reliability may be affected.

*An external diode from the input to the VIN pin is required if bootstrapping VDRV and VIN off of the output voltage.

PACKAGE CAPABILITIES

Characteristic	Value	Unit	
ESD Capability (All Pins)	Human Body Model Machine Model	≥ 2.0 ≥ 200	KV V
Moisture Sensitivity Level	1		
Package Thermal Resistance	Junction-to-Ambient, $R_{\theta JA}$ (Note 1)	100	°C/W

1. 1 in², 1 oz copper area used for heatsinking.

Ordering Options

The NCV898032 features several variants to better fit a multitude of applications. The table below shows the typical

values of parameters for the parts that are currently available.

TYPICAL VALUES

YY	D _{max}	SCE	t _{ss}	S _a	V _{cl}	I _{src}	I _{sink}	V _{DRV}
NCV898032	88%	No	800 μ s	204 mV/ μ s	200 mV	800 mA	600 mA	6.3 V

DEFINITIONS

Symbol	Characteristic	Symbol	Characteristic	Symbol	Characteristic
D _{max}	Maximum duty cycle			t _{ss}	Soft-start time
S _a	Slope compensating ramp	V _{cl}	Current limit trip voltage	I _{src}	Gate drive sourcing current
I _{sink}	Gate drive sinking current	V _{DRV}	Drive voltage	SCE	Short Circuit Enable

NCV898032

ELECTRICAL CHARACTERISTICS ($-40^{\circ}\text{C} < T_J < 150^{\circ}\text{C}$, $3.2\text{ V} < V_{IN} < 40\text{ V}$, unless otherwise specified) Min/Max values are guaranteed by test, design or statistical correlation.

Characteristic	Symbol	Conditions	Min	Typ	Max	Unit
----------------	--------	------------	-----	-----	-----	------

GENERAL

Quiescent Current, Sleep Mode	$I_{q,sleep}$	$V_{IN} = 13.2\text{ V}$, $EN = 0$, $T_J = 25^{\circ}\text{C}$	–	2.0	–	μA
Quiescent Current, Sleep Mode	$I_{q,sleep}$	$V_{IN} = 13.2\text{ V}$, $EN = 0$, $-40^{\circ}\text{C} < T_J < 125^{\circ}\text{C}$	–	2.0	6.0	μA
Quiescent Current, No switching	$I_{q,off}$	Into V_{IN} pin, $EN = 1$, No switching	–	1.9	2.9	mA
Quiescent Current, Switching, normal operation	$I_{q,on}$	Into V_{IN} pin, $EN = 1$, Switching	–	7.5	10	mA

OSCILLATOR

Minimum pulse width	$t_{on,min}$		30	65	90	ns
Maximum duty cycle	D_{max}	$YY = 32$	85	87.5	91	%
Switching frequency	f_s	$YY = 32$	1.8	2.0	2.2	MHz
Soft-start time	t_{ss}	From start of switching with $V_{FB} = 0$ until reference voltage = V_{REF} $YY = 32$	650	800	950	μs
Soft-start delay	$t_{ss,dly}$	From $EN \rightarrow 1$ until start of switching with $V_{FB} = 0$ with floating V_C pin	80	100	280	μs
Slope compensating ramp	S_a	$YY = 32$	179	204	240	$\text{mV}/\mu\text{s}$

ENABLE

EN pull-down current	I_{EN}	$V_{EN} = 5\text{ V}$	–	5.0	10	μA
EN input high voltage	$V_{s,ih}$	$V_{IN} > V_{UVLO}$	2.0	–	5.0	V
EN input low voltage	$V_{s,il}$		0	–	800	mV
EN time-out ratio	$\%t_{en}$	From EN falling edge, to oscillator control (EN high) or shutdown (EN low), Percent of typical switching frequency	–	–	350	%

CURRENT SENSE AMPLIFIER

Low-frequency gain	A_{csa}	Input-to-output gain at dc, $ISNS \leq 1\text{ V}$	0.9	1.0	1.1	V/V
Bandwidth	BW_{csa}	Gain of $A_{csa} - 3\text{ dB}$	2.5	–	–	MHz
ISNS input bias current	$I_{sns,bias}$	Out of ISNS pin	–	30	50	μA
Current limit threshold voltage	V_{cl}	Voltage on ISNS pin $YY = 32$	180	200	220	mV
Current limit, Response time	t_{cl}	CL tripped until GDRV falling edge, $V_{ISNS} = V_{cl}(typ) + 60\text{ mV}$	–	80	125	ns
Overcurrent protection, Threshold voltage	$\%V_{ocp}$	Percent of V_{cl}	125	150	175	%
Overcurrent protection, Response Time	t_{ocp}	From overcurrent event, Until switching stops, $V_{ISNS} = V_{OCP} + 40\text{ mV}$	–	80	125	ns

VOLTAGE ERROR OPERATIONAL TRANSCONDUCTANCE AMPLIFIER

Transconductance	$g_{m,vea}$	$V_{FB} - V_{ref} = \pm 20\text{ mV}$	0.80	1.20	1.63	mS
VEA output resistance	$R_{o,vea}$		2.0	–	–	$\text{M}\Omega$
VFB input bias current	$I_{vfb,bias}$	Current out of VFB pin	–	0.5	2.0	μA
Reference voltage	V_{ref}		0.194	0.200	0.206	V
VEA maximum output voltage	$V_{c,max}$		2.5	–	–	V
VEA minimum output voltage	$V_{c,min}$		–	–	0.3	V
VEA sourcing current	$I_{src,vea}$	VEA output current, $V_c = 2.0\text{ V}$	80	100	–	μA
VEA sinking current	$I_{snk,vea}$	VEA output current, $V_c = 0.7\text{ V}$	80	100	–	μA

NCV898032

ELECTRICAL CHARACTERISTICS ($-40^{\circ}\text{C} < T_J < 150^{\circ}\text{C}$, $3.2\text{ V} < V_{\text{IN}} < 40\text{ V}$, unless otherwise specified) Min/Max values are guaranteed by test, design or statistical correlation.

Characteristic	Symbol	Conditions	Min	Typ	Max	Unit
----------------	--------	------------	-----	-----	-----	------

GATE DRIVER

Sourcing current	I_{src}	$V_{\text{DRV}} \geq 6\text{ V}$, $V_{\text{DRV}} - V_{\text{GDRV}} = 2\text{ V}$ YY = 32	600	800	–	mA
Sinking current	I_{sink}	$V_{\text{GDRV}} \geq 2\text{ V}$ YY = 32	500	600	–	mA
Driving voltage dropout	$V_{\text{drv,do}}$	$V_{\text{IN}} - V_{\text{DRV}}$, $I_{\text{DRV}} = 25\text{ mA}$	–	0.3	0.6	V
Driving voltage source current	I_{drv}	$V_{\text{IN}} - V_{\text{DRV}} = 1\text{ V}$	35	45	–	mA
Backdrive diode voltage drop	$V_{\text{d,bd}}$	$V_{\text{DRV}} - V_{\text{IN}}$, $I_{\text{d,bd}} = 5\text{ mA}$	–	–	0.7	V
Driving voltage	V_{DRV}	$V_{\text{IN}} = 12\text{ V}$, $I_{\text{DRV}} = 0.1 - 25\text{ mA}$ YY = 32	6.0	6.3	6.6	V
Pull-down resistance	R_{pd}		–	15	–	k Ω

UVLO

Undervoltage lock-out, Threshold voltage	V_{uvlo}	V_{IN} falling	2.95	3.05	3.15	V
Undervoltage lock-out, Hysteresis	$V_{\text{uvlo,hys}}$	V_{IN} rising	50	150	250	mV

THERMAL SHUTDOWN

Thermal shutdown threshold	T_{sd}	T_J rising	160	170	180	$^{\circ}\text{C}$
Thermal shutdown hysteresis	$T_{\text{sd,hys}}$	T_J falling	10	15	20	$^{\circ}\text{C}$
Thermal shutdown delay	$t_{\text{sd,dly}}$	From $T_J > T_{\text{sd}}$ to stop switching	–	–	100	ns

TYPICAL PERFORMANCE CHARACTERISTICS

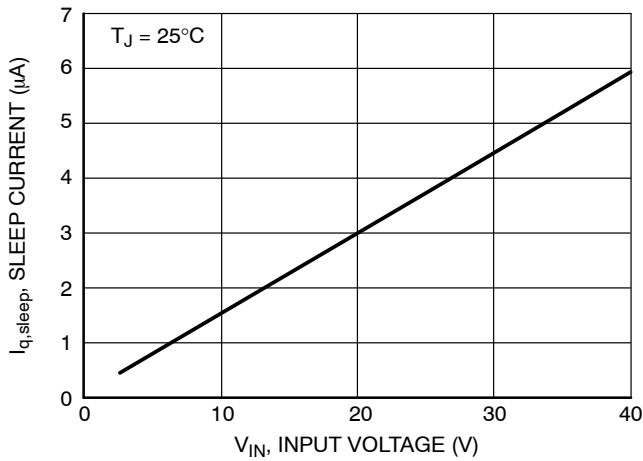

Figure 2. Sleep Current vs. Input Voltage

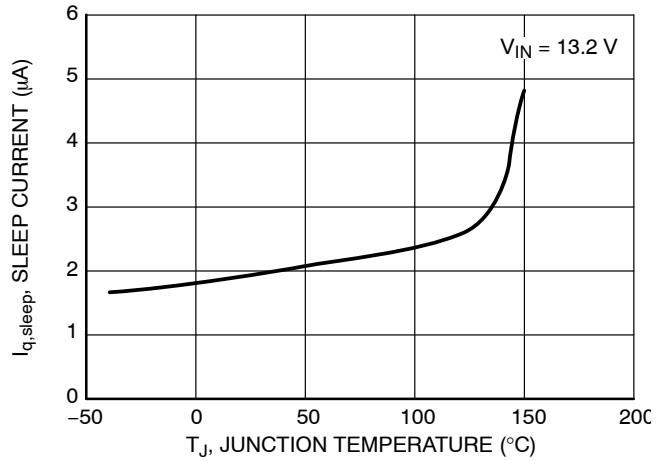

Figure 3. Sleep Current vs. Temperature

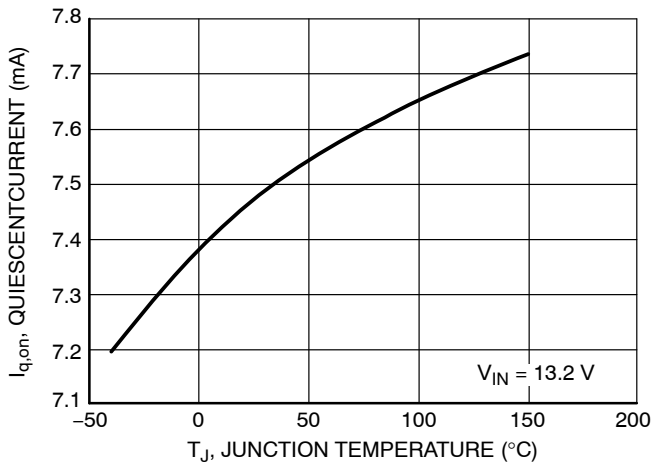

Figure 4. Quiescent Current vs. Temperature

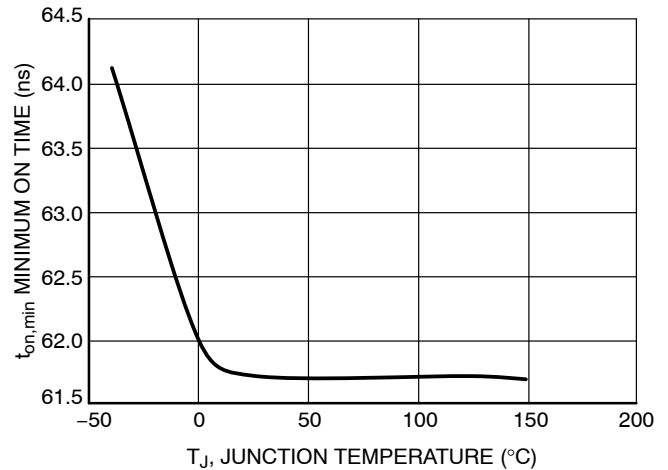

Figure 5. Minimum On Time vs. Temperature

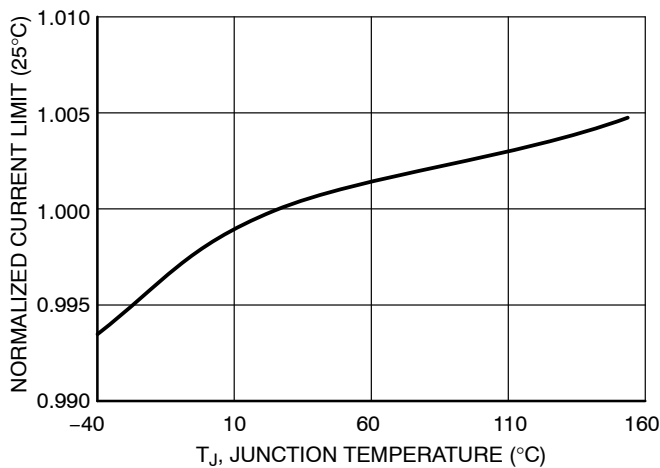

Figure 6. Normalized Current Limit vs. Temperature

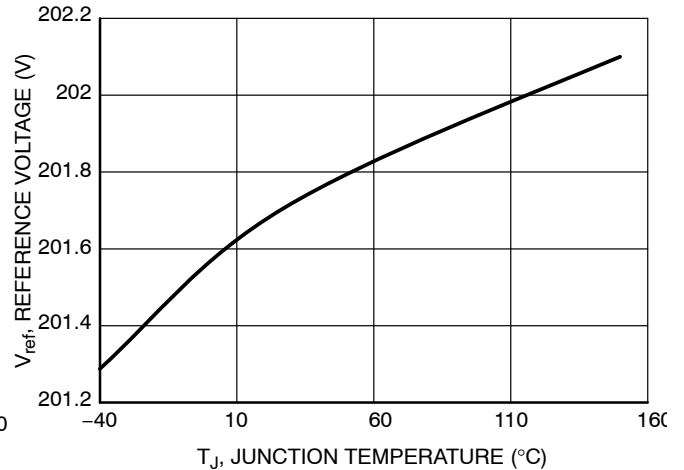

Figure 7. Reference Voltage vs. Temperature

TYPICAL PERFORMANCE CHARACTERISTICS

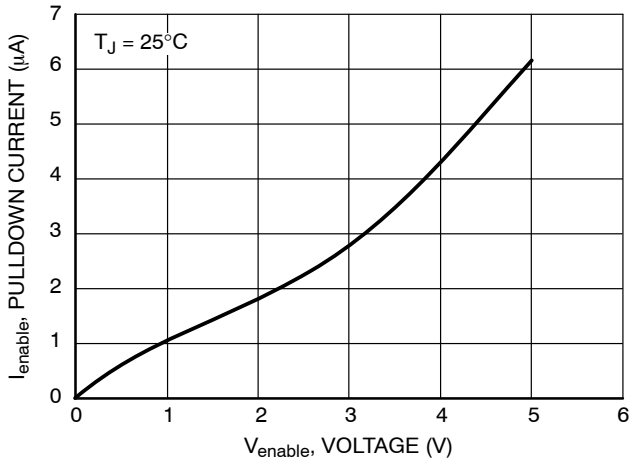

Figure 8. Enable Pulldown Current vs. Voltage

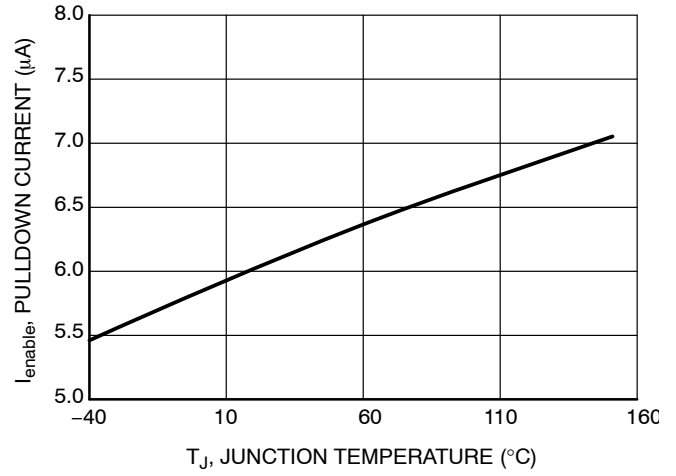

Figure 9. Enable Pulldown Current vs. Temperature

THEORY OF OPERATION

Current Mode Control

The NCV898032 incorporates a current mode control scheme, in which the PWM ramp signal is derived from the power switch current. This ramp signal is compared to the output of the error amplifier to control the on-time of the power switch. The oscillator is used as a fixed-frequency clock to ensure a constant operational frequency. The resulting control scheme features several advantages over conventional voltage mode control. First, derived directly from the inductor, the ramp signal responds immediately to line voltage changes. This eliminates the delay caused by the output filter and error amplifier, which is commonly found in voltage mode controllers. The second benefit comes from inherent pulse-by-pulse current limiting by merely clamping the peak switching current. Finally, since current mode commands an output current rather than voltage, the filter offers only a single pole to the feedback loop. This allows for a simpler compensation.

The NCV898032 also includes a slope compensation scheme in which a fixed ramp generated by the oscillator is added to the current ramp. A proper slope rate is provided to improve circuit stability without sacrificing the advantages of current mode control.

Current Limit

The NCV898032 features a peak current-mode current limit protection. When the current sense amplifier detects a voltage above the peak current limit between ISNS and GND after the current limit leading edge blanking time, the peak current limit causes the power switch to turn off for the remainder of the cycle. Set the current limit with a resistor from ISNS to GND, with $R = V_{CL} / I_{limit}$.

If the voltage across the current sense resistor exceeds the over current threshold voltage the part enters over current hiccup mode. The part will remain off for the hiccup time and then go through the soft-start procedure.

EN

This pin has two modes. When a dc logic high (CMOS/TTL compatible) voltage is applied to this pin the NCV898032 operates at the programmed frequency. When a dc logic low voltage is applied to this pin the NCV898032 enters a low quiescent current sleep mode. If an Enable command is received during normal operation, the minimum duration of the Enable low-state must be greater than 7 clock cycles. The NCV898032 requires 2 clock cycles after the falling edge of the Enable signal to stop switching.

UVLO

Input Undervoltage Lockout (UVLO) is provided to ensure that unexpected behavior does not occur when VIN is too low to support the internal rails and power the controller. The IC will start up when enabled and VIN surpasses the UVLO threshold plus the UVLO hysteresis and will shut down when VIN drops below the UVLO threshold or the part is disabled.

It is highly recommended to keep EN pin voltage at a lower amplitude than the VIN pin voltage during a UVLO event.

Internal Soft-Start

To insure moderate inrush current and reduce output overshoot, the NCV898032 features a soft start which charges a capacitor with a fixed current to ramp up the reference voltage.

APPLICATION INFORMATION

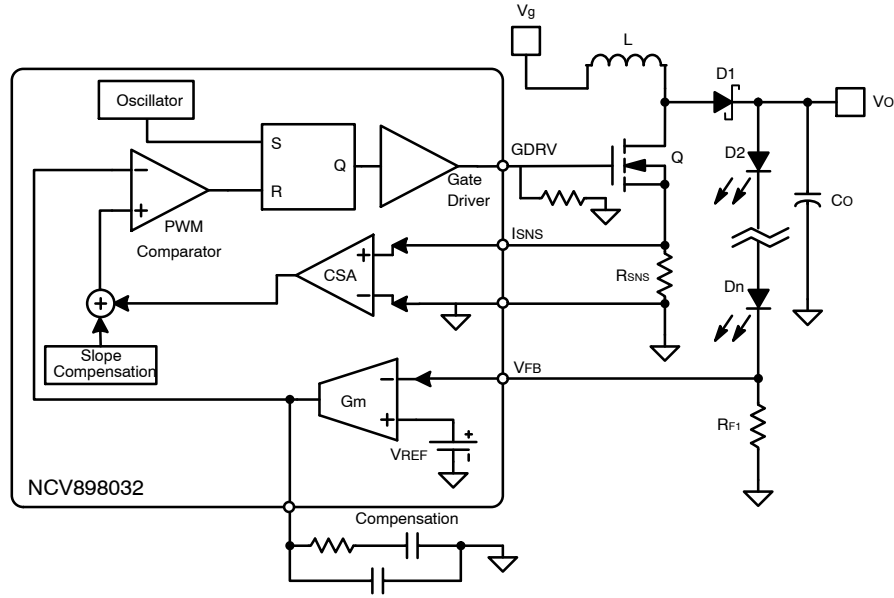

Figure 10. Current Mode Control Schematic

Boost LED Design Methodology

This section details an overview of the component selection process for the NCV898032 in discontinuous conduction mode (DCM) Boost converter operation with a high brightness LED (100–150 mA typical) string as a load. LED current is used for the feedback signal. It is intended to assist with the design process but does not remove all engineering design work. Many of the equations make use of the small ripple approximation. This process entails the following steps:

1. Define Operational Parameters
2. Select Current Sense Resistor
3. Select Output Inductor
4. Select Output Capacitors
5. Select Input Capacitors
6. Select Feedback Resistors
7. Select Compensator Components
8. Select MOSFET(s)
9. Select Diode

1. Define Operational Parameters

Before beginning the design, define the operating parameters of the application. These include:

- $V_{IN(min)}$: minimum input voltage [V]
- $V_{IN(max)}$: maximum input voltage [V]
- V_{OUT} : output voltage [V]
- I_{LED} : LED current [A]
- I_{CL} : desired typical cycle-by-cycle current limit [A]
- V_{ref} : NCV898032 feedback reference voltage = 0.2 V
- I_L : inductor current [A]

From this the ideal minimum and maximum duty cycles can be calculated as follows:

$$M_{min} = \frac{V_{out}}{V_{in(max)}}$$

$$M_{max} = \frac{V_{out}}{V_{in(min)}}$$

$$R_{out} = \frac{V_{out}}{I_{LED}}$$

$$D_{min} = \sqrt{\frac{L_f s}{2R_{out}} \left[(2M_{min} - 1)^2 - 1 \right]}$$

$$D_{max} = \sqrt{\frac{L_f s}{2R_{out}} \left[(2M_{max} - 1)^2 - 1 \right]}$$

$$\delta = \frac{2V_{out}^2}{V_{in} R_{out} I_{L,peak}} - D ,$$

Where: $(D + \delta) < 1$ for DCM operation IL.

Both duty cycles will actually be slightly higher due to power loss in the conversion. The exact duty cycles depend on conduction and switching losses. If the maximum input voltage is higher than the output voltage, the minimum duty cycle will be a complex value. This is because a Boost converter cannot have an output voltage lower than the input voltage. In situations where the input voltage is higher than the output, the output will follow the input (minus the diode drop of the Boost diode) and the converter will not attempt to switch.

If the inductor value is too large, continuous conduction mode (CCM) operation will occur and a right-half-plane (RHP) zero appears which can result in operation instability.

If the calculated D_{max} is higher than the D_{max} of the NCV898032, the conversion will not be possible. It is important for a Boost converter to have a restricted D_{max} , because while the ideal conversion ration of a Boost converter goes up to infinity as D approaches 1, a real converter's conversion ratio starts to decrease as losses

overtake the increased power transfer. If the converter is in this range it will not be able to maintain output regulation.

If the following equation is not satisfied, the device will skip pulses at high V_{IN} :

$$\frac{D_{min}}{f_s} \geq t_{on(min)}$$

Where: f_s : switching frequency [Hz]

$t_{on(min)}$: minimum on time [s]

2. Select Current Sense Resistor

Current sensing for peak current mode control and current limit relies on the MOSFET current signal, which is measured with a ground referenced amplifier. The easiest method of generating this signal is to use a current sense resistor between the MOSFET source and ground. The sense resistor should be selected as follows:

$$R_{SNS} = \frac{V_{CL}}{I_{CL}}$$

Where: R_{SNS} : sense resistor [Ω]

V_{CL} : current limit threshold voltage [V]

I_{CL} : desired current limit [A]

3. Select the Boost Inductor

The Boost inductor controls the current ripple that occurs over a switching period. A discontinuous current ripple will result in superior transient response and lower switching noise at the expense of higher transistor conduction losses and operating ripple current requirements. A low current ripple will result in CCM operation having a slower response current slew rate in case of load steps (e.g. introducing an LED series dimming circuit). A good starting point is to select components for DCM operation at $V_{in(min)}$, but operation should be verified empirically. Calculate the maximum inductor value as follows:

$$L_{max} = \frac{\left(1 - \frac{1}{M_{max}}\right) V_{in(min)}^2 \left(\frac{V_{out}}{I_{LED}}\right)}{2f_s V_{out}^2}$$

The maximum average inductor current can be calculated as follows:

$$I_{L,avg} = \frac{V_{OUT} I_{OUT(max)}}{V_{IN(min)}}$$

The peak inductor current can be calculated as follows:

$$I_{L,peak} = \frac{V_{IN(min)} D_{max}}{L f_s}$$

Where: $I_{L,peak}$: Peak inductor current value [A]

4. Select Output Capacitor

The output capacitor smoothes the output voltage and reduces the overshoot and undershoot associated with line transients. The steady state output ripple associated with the output capacitors can be calculated as follows:

$$V_{OUT(ripple)} = \frac{I_{LED}(1 - \delta(M_{max}))}{f_s C_{OUT}}$$

The capacitors must withstand an RMS ripple current as follows:

$$I_{Cout(RMS)} = \sqrt{I_{LED}^2 + \delta(M_{max}) \left(\frac{I_{L,pk}^2}{3} - I_{L,pk} I_{LED} \right)}$$

A 1–2.2 μ F ceramic capacitor is usually sufficient for high brightness LED applications for $f_s = 2$ MHz.

5. Select Input Capacitors

The input capacitor reduces voltage ripple on the input to the module associated with the ac component of the input current.

$$I_{Cin(RMS)} = \sqrt{\left(\frac{D(M_{max}) + \delta(M_{max})}{3} \right) I_{L,pk}^2 - I_{L,avg}^2}$$

6. Select Feedback Resistors

The feedback resistor provides LED current sensing for the feedback signal. It may be calculated as follows:

$$R_{F1} = \frac{V_{ref}}{I_{LED}}$$

7. Select Compensator Components

Current Mode control method employed by the NCV898032 allows the use of a simple Type II compensation to optimize the dynamic response according to system requirements. A transconductance amplifier is used, so compensation components must be connected between the compensation pin and ground.

8. Select MOSFET(s)

In order to ensure the gate drive voltage does not drop out, the selected MOSFET must not violate the following inequality:

$$Q_{g(total)} \leq \frac{I_{drv}}{f_s}$$

Where: $Q_{g(total)}$: Total Gate Charge of MOSFET(s) [C]

I_{drv} : Drive voltage current [A]

f_s : Switching Frequency [Hz]

The maximum RMS Current can be calculated as follows:

$$I_{Q(max)} = I_{L,peak} \sqrt{\frac{D(M_{max})}{3}}$$

The maximum voltage across the MOSFET will be the maximum output voltage, which is the higher of the maximum input voltage and the regulated output voltage:

$$V_{Q(max)} = V_{OUT(max)}$$

9. Select Diode

The output diode rectifies the output current. The average current through diode will be equal to the output current:

$$I_{D(\text{avg})} = I_{\text{OUT}(\text{max})}$$

Additionally, the diode must block voltage equal to the higher of the output voltage or the maximum input voltage:

$$V_{D(\text{max})} = V_{\text{OUT}}$$

The maximum power dissipation in the diode can be calculated as follows:

$$P_D = V_{f(\text{max})} I_{\text{OUT}(\text{max})}$$

Where: P_d : Power dissipation in the diode [W]

$V_{f(\text{max})}$: Maximum forward voltage of the diode [V]

Low Voltage Operation

If the input voltage drops below the UVLO or MOSFET threshold voltage, another voltage may be used to power the device. Simply connect the voltage you would like to boost to the inductor and connect the stable voltage to the VIN pin of the device. In Boost configuration, the output of the converter can be used to power the device. In some cases it may be desirable to connect 2 sources to VIN pin, which can be accomplished simply by connecting each of the sources through a diode to the VIN pin.

SEPIC TOPOLOGY APPLICATION INFORMATION

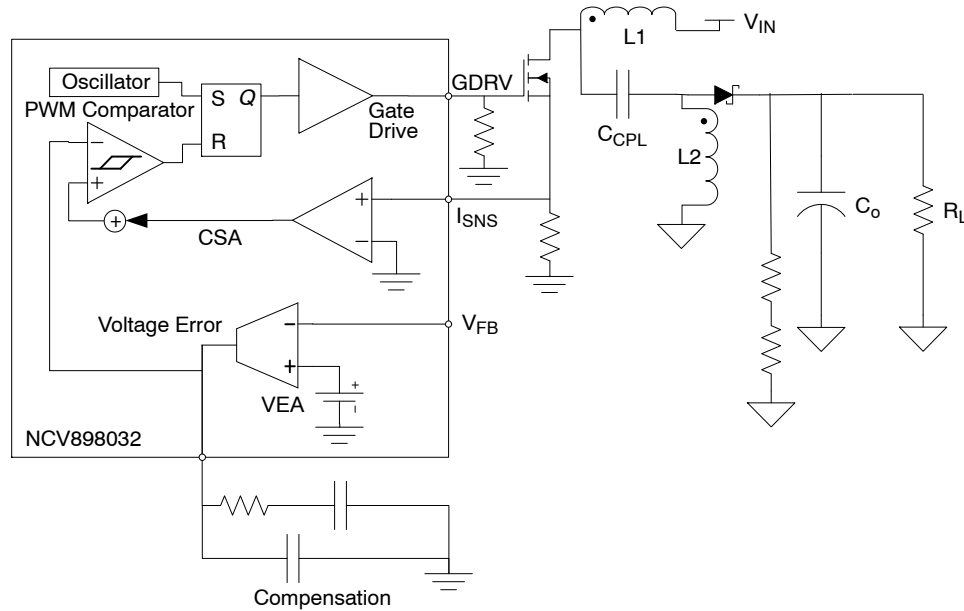

Figure 11. SEPIC Current Mode Schematic

SEPIC Design Methodology

This section details an overview of the component selection process for the NCV898032 in continuous conduction mode SEPIC. It is intended to assist with the design process but does not remove all engineering design work. Many of the equations make heavy use of the small ripple approximation. This process entails the following steps:

1. Define Operational Parameters
2. Select Current Sense Resistor
3. Select SEPIC Inductors
4. Select Coupling Capacitor
5. Select Output Capacitors
6. Select Input Capacitors
7. Select Feedback Resistors
8. Select Compensator Components
9. Select MOSFET(s)
10. Select Diode

1. Define Operational Parameters

Before beginning the design, define the operating parameters of the application. These include:

- $V_{IN(min)}$: minimum input voltage [V]
- $V_{IN(max)}$: maximum input voltage [V]
- V_{OUT} : output voltage [V]
- $I_{OUT(max)}$: maximum output current [A]
- I_{CL} : desired typical cycle-by-cycle current limit [A]

From this the ideal minimum and maximum duty cycles can be calculated as follows:

$$D_{min} = \frac{V_{OUT}}{V_{IN(max)} + V_{OUT}}$$

$$D_{max} = \frac{V_{OUT}}{V_{IN(min)} + V_{OUT}}$$

Both duty cycles will actually be higher due to power loss in the conversion. The exact duty cycles will depend on conduction and switching losses.

If the calculated D_{WC} (worst case) is higher than the D_{max} limit of the NCV898032, the conversion will not be possible. It is important for a SEPIC converter to have a restricted D_{max} , because while the ideal conversion ratio of a SEPIC converter goes up to infinity as D approaches 1, a real converter's conversion ratio starts to decrease as losses overtake the increased power transfer. If the converter is in this range it will not be able to regulate properly.

If the following equation is not satisfied, the device will skip pulses at high V_{IN} :

$$\frac{D_{min}}{f_s} \geq t_{on(min)}$$

Where: f_s : switching frequency [Hz]
 $t_{on(min)}$: minimum on time [s]

2. Select Current Sense Resistor

Current sensing for peak current mode control and current limit relies on the MOSFET current signal, which is measured with a ground referenced amplifier. Note that the I_{CL} equals the sum of the currents from both inductors. The easiest method of generating this signal is to use a current sense resistor from the source of the MOSFET to device ground. The sense resistor should be selected as follows:

$$R_S = \frac{V_{CL}}{I_{CL}}$$

Where: R_S : sense resistor [Ω]

V_{CL} : current limit threshold voltage [V]

I_{CL} : desire current limit [A]

3. Select SEPIC Inductors

The output inductor controls the current ripple that occurs over a switching period. A high current ripple will result in excessive power loss and ripple current requirements. A low current ripple will result in a poor control signal and a slow current slew rate in case of load steps. A good starting point for peak to peak ripple is around 20–40% of the inductor current at the maximum load at the worst case V_{IN} , but operation should be verified empirically. The worst case V_{IN} is the minimum input voltage. After choosing a peak current ripple value, calculate the inductor value as follows:

$$L = \frac{V_{IN(WC)} D_{WC}}{\Delta I_{L,max} f_s}$$

Where: $V_{IN(WC)}$: V_{IN} value as close as possible to half of V_{OUT} [V]

D_{WC} : duty cycle at $V_{IN(WC)}$

$\Delta I_{L,max}$: maximum peak to peak ripple [A]

The maximum average inductor current can be calculated as follows:

$$I_{L,AVG} = \frac{V_{OUT} I_{OUT(max)}}{V_{IN(min)} \eta}$$

The Peak Inductor current can be calculated as follows:

$$I_{L1,peak} = I_{L1,avg} + \frac{\Delta I_{L1}}{2}$$

$$I_{L2,peak} = I_{OUT(max)} + \frac{\Delta I_{L2}}{2}$$

Where (if $L1 = L2$): $\Delta I_{L1} = \Delta I_{L2}$

4. Select Coupling Capacitor

Coupling capacitor RMS current is significant. A low ESR ceramic capacitor is required as a coupling capacitor. Selecting a capacitor value too low will result in high capacitor ripple voltage which will distort ripple current and diminish input line regulation capability. Budgeting 2–5% coupling capacitor ripple voltage is a reasonable guideline.

$$\Delta V_{coupling} = \frac{I_{out} D_{WC}}{C_{coupling} f_s}$$

Current mode control helps resolve some of the resonant frequencies that create issues in voltage mode SEPIC converter designs, but some resonance issues may occur. A resonant frequency exists at

$$f_{resonance} = \frac{1}{2\pi \sqrt{(L1 + L2)C_{coupling}}}$$

It may become necessary to place an RC damping network in parallel with the coupling capacitor if the resonance is within ~ 1 decade of the closed-loop crossover frequency. The capacitance of the damping capacitor should be ~ 5 times that of the coupling capacitor. The optimal damping resistance (including the ESR of the damping capacitor) is calculated as

$$R_{damping} = \sqrt{\frac{L1 + L2}{C_{coupling}}}$$

5. Select Output Capacitors

The output capacitors smooth the output voltage and reduce the overshoot and undershoot associated with line transients. The steady state output ripple associated with the output capacitors can be calculated as follows:

$$V_{OUT(ripple)} = \frac{I_{OUT(max)} D_{WC}}{C_{OUT} f_s} + \left(\frac{I_{OUT(max)}}{1 - D_{WC}} + \frac{D_{WC} V_{IN(min)}}{2 f_s L_2} \right) R_{esr}$$

The capacitors need to survive an RMS ripple current as follows:

$$I_{Cout(RMS)} = \sqrt{I_{OUT(max)}^2 D_{WC} + \left(I_a^2 + \frac{I_r^2}{3} - I_a I_r \right) D'_{WC}}$$

where

$$I_a = I_{L1,peak} + I_{L2,peak} - I_{out}$$

$$I_r = \Delta I_{L1} + \Delta I_{L2}$$

The use of parallel ceramic bypass capacitors is strongly encouraged to help with the transient response.

6. Select Input Capacitors

The input capacitor reduces voltage ripple on the input to the module associated with the ac component of the input current.

$$I_{Cin(RMS)} = \frac{\Delta I_{L1}}{\sqrt{12}}$$

7. Select Feedback Resistors

The feedback resistors form a resistor divider from the output of the converter to ground, with a tap to the feedback pin. During regulation, the divided voltage will equal V_{ref} . The lower feedback resistor can be chosen, and the upper feedback resistor value is calculated as follows:

$$R_{upper} = R_{lower} \frac{(V_{out} - V_{ref})}{V_{ref}}$$

The total feedback resistance ($R_{upper} + R_{lower}$) should be in the range of 1 k Ω – 100 k Ω .

8. Select Compensator Components

Current Mode control method employed by the NCV898032 allows the use of a simple, Type II compensation to optimize the dynamic response according to system requirements.

The maximum RMS Current can be calculated as follows:

$$I_{D(max)} = \sqrt{D_{WC} \left(I_{Q(peak)}^2 + \frac{(\Delta I_{L1} + \Delta I_{L2})^2}{3} - I_{Q(peak)}(\Delta I_{L1} + \Delta I_{L2}) \right)}$$

where

$$I_{Q(peak)} = I_{L1_peak} + I_{L2_peak}$$

The maximum voltage across the MOSFET will be the maximum output voltage, which is the higher of the maximum input voltage and the regulated output voltage:

$$V_{Q(max)} = V_{OUT(max)} + V_{IN(max)}$$

9. Select MOSFET(s)

In order to ensure the gate drive voltage does not drop out the MOSFET(s) chosen must not violate the following inequality:

$$Q_{g(total)} \leq \frac{I_{drv}}{f_s}$$

Where: $Q_{g(total)}$: Total Gate Charge of MOSFET(s) [C]

I_{drv} : Drive voltage current [A]

f_s : Switching Frequency [Hz]

10. Select Diode

The output diode rectifies the output current. The average current through diode will be equal to the output current:

$$I_{D(avg)} = I_{OUT(max)}$$

Additionally, the diode must block voltage equal to the higher of the output voltage and the maximum input voltage:

$$V_{D(max)} = V_{OUT(max)} + V_{IN(max)}$$

The maximum power dissipation in the diode can be calculated as follows:

$$P_D = V_{f(max)} I_{OUT(max)}$$

Where: P_d : Power dissipation in the diode [W]

$V_{f(max)}$: Maximum forward voltage of the diode [V]

BOOST TOPOLOGY APPLICATION INFORMATION

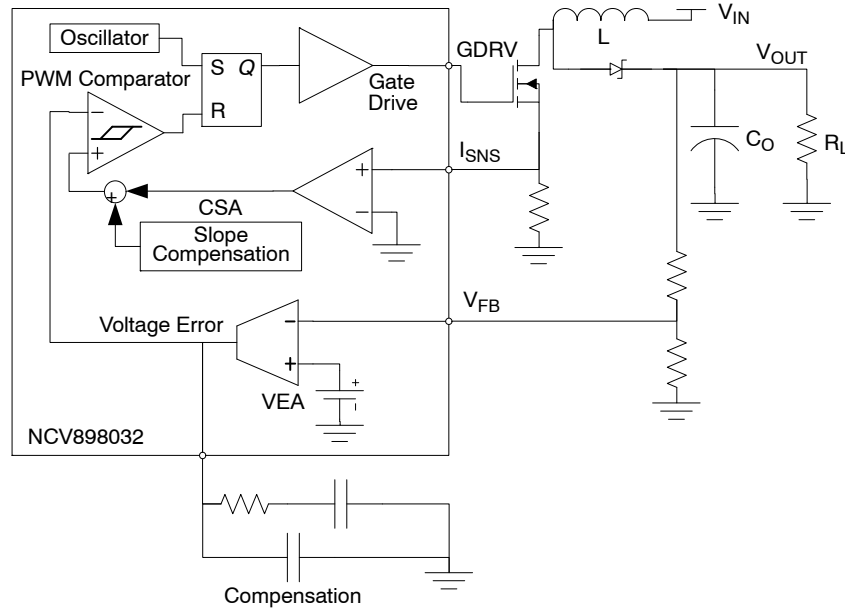

Figure 12. Boost Current Mode Schematic

Boost Converter Design Methodology

This section details an overview of the component selection process for the NCV898032 in continuous conduction mode boost. It is intended to assist with the design process but does not remove all engineering design work. Many of the equations make heavy use of the small ripple approximation. This process entails the following steps:

1. Define Operational Parameters
2. Select Current Sense Resistor
3. Select Output Inductor
4. Select Output Capacitors
5. Select Input Capacitors
6. Select Feedback Resistors
7. Select Compensator Components
8. Select MOSFET(s)
9. Select Diode
10. Determine Feedback Loop Compensation Network

1. Define Operational Parameters

Before beginning the design, define the operating parameters of the application. These include:

- $V_{IN(min)}$: minimum input voltage [V]
- $V_{IN(max)}$: maximum input voltage [V]
- V_{OUT} : output voltage [V]
- $I_{OUT(max)}$: maximum output current [A]
- I_{CL} : desired typical cycle-by-cycle current limit [A]

From this the ideal minimum and maximum duty cycles can be calculated as follows:

$$D_{min} = 1 - \frac{V_{IN(max)}}{V_{OUT}}$$

$$D_{WC} = 1 - \frac{V_{IN(WC)}}{V_{OUT}}$$

Both duty cycles will actually be higher due to power loss in the conversion. The exact duty cycles will depend on conduction and switching losses. If the maximum input voltage is higher than the output voltage, the minimum duty cycle will be negative. This is because a boost converter cannot have an output lower than the input. In situations where the input is higher than the output, the output will follow the input, minus the diode drop of the output diode and the converter will not attempt to switch.

If the calculated D_{WC} is higher than the D_{max} limit of the NCV898032, the conversion will not be possible. It is important for a boost converter to have a restricted D_{max} , because while the ideal conversion ratio of a boost converter goes up to infinity as D approaches 1, a real converter's conversion ratio starts to decrease as losses overtake the increased power transfer. If the converter is in this range it will not be able to regulate properly.

If the following equation is not satisfied, the device will skip pulses at high V_{IN} :

$$\frac{D_{min}}{f_s} \geq t_{on(min)}$$

Where: f_s : switching frequency [Hz]

$t_{on(min)}$: minimum on time [s]

2. Select Current Sense Resistor

Current sensing for peak current mode control and current limit relies on the MOSFET current signal, which is measured with a ground referenced amplifier. The easiest method of generating this signal is to use a current sense resistor from the source of the MOSFET to device ground. The sense resistor should be selected as follows:

$$R_S = \frac{V_{CL}}{I_{CL}}$$

Where: R_S : sense resistor [Ω]

V_{CL} : current limit threshold voltage [V]

I_{CL} : desire current limit [A]

3. Select Output Inductor

The output inductor controls the current ripple that occurs over a switching period. A high current ripple will result in excessive power loss and ripple current requirements. A low current ripple will result in a poor control signal and a slow current slew rate in case of load steps. A good starting point for peak to peak ripple is around 20–40% of the inductor current at the maximum load at the worst case V_{IN} , but operation should be verified empirically. The worst case V_{IN} is half of V_{OUT} , or whatever V_{IN} is closest to half of V_{IN} . After choosing a peak current ripple value, calculate the inductor value as follows:

$$L = \frac{V_{IN(WC)}^2 D_{WC}}{\Delta I_{L,max} f_s V_{OUT}}$$

Where: $V_{IN(WC)}$: V_{IN} value as close as possible to half of V_{OUT} [V]

D_{WC} : duty cycle at $V_{IN(WC)}$

$\Delta I_{L,max}$: maximum peak to peak ripple [A]

The maximum average inductor current can be calculated as follows:

$$I_{L,avg} = \frac{V_{OUT} I_{OUT(max)}}{V_{IN(min)}}$$

The Peak Inductor current can be calculated as follows:

$$I_{L,peak} = I_{L,avg} + \frac{V_{IN(min)}^2 D_{WC}}{L f_s V_{OUT}}$$

Where: $I_{L,peak}$: Peak inductor current value [A]

4. Select Output Capacitors

The output capacitors smooth the output voltage and reduce the overshoot and undershoot associated with line transients. The steady state output ripple associated with the output capacitors can be calculated as follows:

$$V_{OUT(ripple)} = \frac{D I_{OUT(max)}}{f C_{OUT}} + \left(\frac{I_{OUT(max)}}{1 - D} + \frac{V_{IN(min)} D}{2 f L} \right) R_{ESR}$$

The capacitors need to survive an RMS ripple current as follows:

$$I_{Cout(RMS)} = I_{OUT} \sqrt{\frac{D_{WC}}{D'_{WC}} + \frac{D_{WC}}{12} \left(\frac{D'_{WC}}{\frac{L}{R_{OUT} \times T_{SW}}} \right)^2}$$

The use of parallel ceramic bypass capacitors is strongly encouraged to help with the transient response.

5. Select Input Capacitors

The input capacitor reduces voltage ripple on the input to the module associated with the ac component of the input current.

$$I_{Cin(RMS)} = \frac{V_{IN(WC)}^2 D_{WC}}{L f_s V_{OUT} 2 \sqrt{3}}$$

6. Select Feedback Resistors

The feedback resistors form a resistor divider from the output of the converter to ground, with a tap to the feedback pin. During regulation, the divided voltage will equal V_{ref} . The lower feedback resistor can be chosen, and the upper feedback resistor value is calculated as follows:

$$R_{upper} = R_{lower} \frac{(V_{out} - V_{ref})}{V_{ref}}$$

The total feedback resistance ($R_{upper} + R_{lower}$) should be in the range of 1 k Ω – 100 k Ω .

7. Select Compensator Components

Current Mode control method employed by the NCV898032 allows the use of a simple, Type II compensation to optimize the dynamic response according to system requirements.

8. Select MOSFET(s)

In order to ensure the gate drive voltage does not drop out the MOSFET(s) chosen must not violate the following inequality:

$$Q_{g(total)} \leq \frac{I_{drv}}{f_s}$$

Where: $Q_{g(total)}$: Total Gate Charge of MOSFET(s) [C]

I_{drv} : Drive voltage current [A]

f_s : Switching Frequency [Hz]

The maximum RMS Current can be calculated as follows:

$$I_{Q(max)} = I_{out} \frac{\sqrt{D_{WC}}}{D'_{WC}}$$

The maximum voltage across the MOSFET will be the maximum output voltage, which is the higher of the maximum input voltage and the regulated output voltage:

$$V_{Q(max)} = V_{OUT(WC)}$$

9. Select Diode

The output diode rectifies the output current. The average current through diode will be equal to the output current:

$$I_{D(avg)} = I_{OUT(max)}$$

Additionally, the diode must block voltage equal to the higher of the output voltage and the maximum input voltage:

$$V_{D(max)} = V_{OUT(max)}$$

The maximum power dissipation in the diode can be calculated as follows:

$$P_D = V_{f(max)} I_{OUT(max)}$$

Where: P_d : Power dissipation in the diode [W]

$V_{f(max)}$: Maximum forward voltage of the diode [V]

10. Determine Feedback Loop Compensation Network

The purpose of a compensation network is to stabilize the dynamic response of the converter. By optimizing the compensation network, stable regulation response is achieved for input line and load transients.

Compensator design involves the placement of poles and zeros in the closed loop transfer function. Losses from the boost inductor, MOSFET, current sensing and boost diode losses also influence the gain and compensation expressions. The OTA has an ESD protection structure ($R_{ESD} \approx 502 \Omega$, data not provided in the datasheet) located on the die between the OTA output and the IC package

compensation pin (VC). The information from the OTA PWM feedback control signal (V_{CTRL}) may differ from the IC-VC signal if R_2 is of similar order of magnitude as R_{ESD} . The compensation and gain expressions which follow take influence from the OTA output impedance elements into account.

Type-I compensation is not possible due to the presence of R_{ESD} . The Figures 13 and 14 compensation networks correspond to a Type-II network in series with R_{ESD} . The resulting control-output transfer function is an accurate mathematical model of the IC in a boost converter topology. The model does have limitations and a more accurate SPICE model should be considered for a more detailed analysis:

- The attenuating effect of large value ceramic capacitors in parallel with output electrolytic capacitor ESR is not considered in the equations.
- The CCM Boost control-output transfer function includes operating efficiency as a correction factor to improve modeling accuracy under low input voltage and high output current operating conditions where operating losses becomes significant.

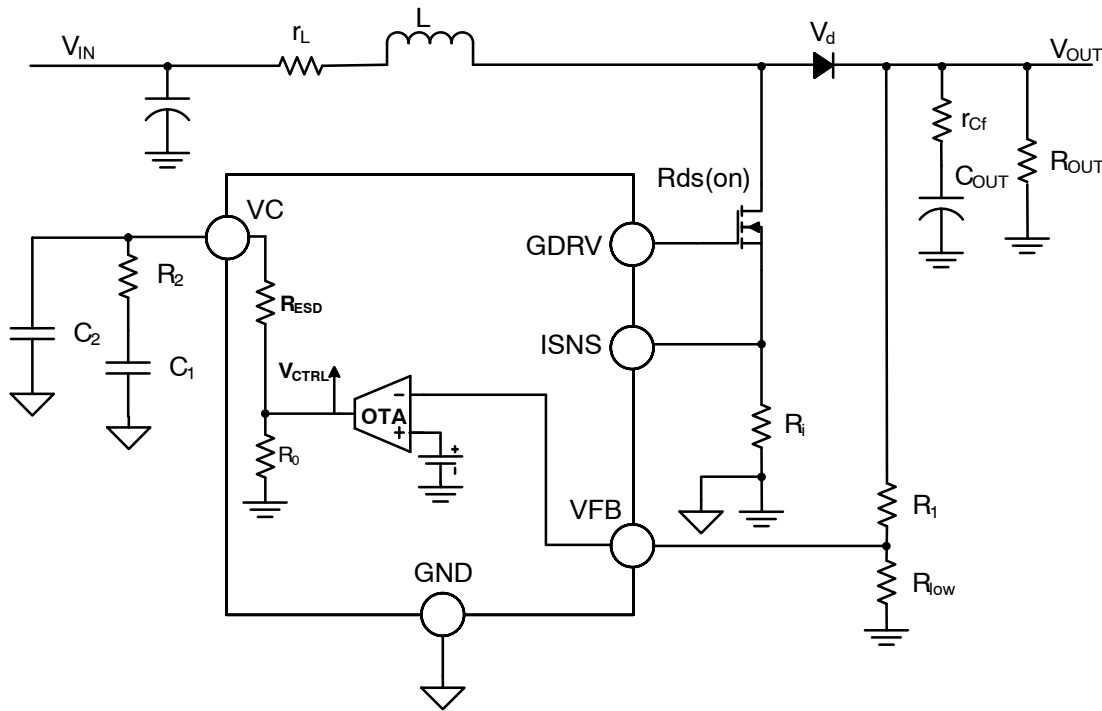

Figure 13. NCV898032 Boost Converter OTA and Compensation

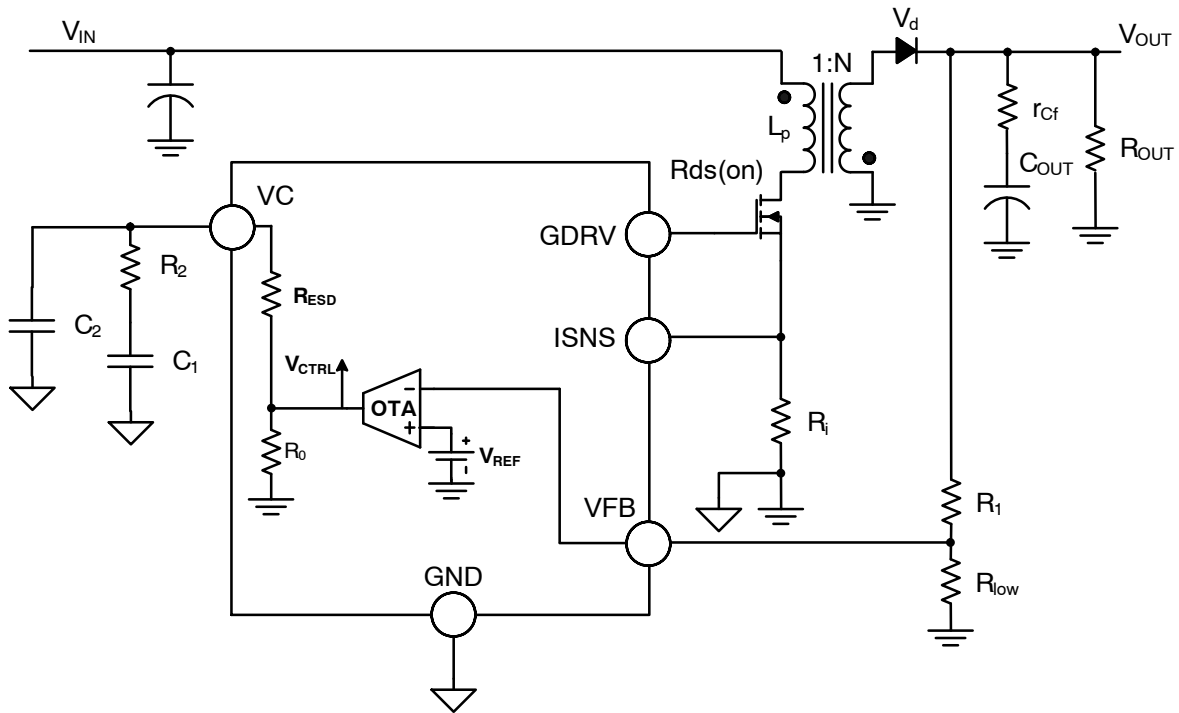

Figure 14. NCV898032 Flyback Converter OTA and Compensation

The following equations may be used to select compensation components R_2 , C_1 , C_2 for Figures 13 & 14 power supply. Required input design parameters for analysis are:

V_d = Output diode V_f (V)

V_{IN} = Power supply input voltage (V)

$N = N_s/N_p$ (Flyback transformer turns ratio)

R_i = Current sense resistor (Ω)

$R_{DS(on)}$ = MOSFET $R_{DS(on)}$ (Ω)

$(R_{sw_eq} = R_{DS(on)} + R_i$ for the boost continuous conduction mode (CCM) expressions)

C_{OUT} = Bulk output capacitor value (F)

r_{CF} = Bulk output capacitor ESR (Ω)

R_{OUT} = Equivalent resistance of output load (Ω)

P_{out} = Output Power (W)

L = Boost inductor value or flyback transformer primary side inductance (H)

r_L = Boost inductor ESR (Ω)

$T_s = 1/f_s$, where $f_s = 2$ MHz clock frequency

R_1 and R_{low} = Feedback resistor divider values used to set the output voltage (Ω)

V_{OUT} = Device specific output voltage (defined by R_1 and R_{low} values) (V)

R_0 = OTA output resistance = 3 M Ω

S_a = IC slope compensation (e.g. 34 mV/ μ s for NCV898032)

g_m = OTA transconductance = 1.2 mS

D = Controller duty ratio

D' = 1 - D

Necessary equations for describing the modulator gain (V_{ctrl} -to- V_{out} gain) $H_{ctrl_output}(f)$ are described next. Boost continuous conduction mode (CCM) and discontinuous conduction mode (DCM) transfer function expressions are summarized in Table 1. Flyback CCM and DCM transfer function expressions are summarized in Table 2.

Table 1. BOOST CCM AND DCM TRANSFER FUNCTION EXPRESSIONS

	CCM	DCM
Duty Ratio (D)	$\frac{2R_{OUT}V_dV_{IN} - \left[R_{sw_eq} + R_{OUT} \left(\frac{V_{IN}}{V_{OUT}} - 2 \right) \right] V_{OUT}^2}{-V_{OUT} \sqrt{R_{OUT} \left(R_{OUT}V_{IN}^2 + 2R_{sw_eq}V_{IN}V_{OUT} - 4V_dR_{sw_eq}V_{IN} \right) - 4R_{sw_eq}V_{OUT}^2 - 4r_LV_dV_{IN} - 4r_LV_{OUT}^2} + R_{sw_eq}^2V_{OUT}^2}$ $2R_{OUT}(V_{OUT}^2 + V_dV_{IN})$	$\sqrt{2\tau_L M(M-1)}$ <p>Where: $\tau_L = \frac{L}{R_{OUT}T_s}$</p>
V_{OUT}/V_{IN} DC Conversion Ratio (M)	$\frac{1}{1-D} \left[1 - \frac{(1-D)V_d}{V_{OUT}} \right] \left[\frac{1}{1 + \frac{1}{(1-D)^2 \left(\frac{r_L + DR_{sw_eq}}{R_{OUT}} \right)}} \right]$	$\frac{1}{2} \left(1 + \sqrt{1 + \frac{2D^2}{\tau_L}} \right)$
Inductor On-slope (S_n), V/s	$\frac{V_{IN} - I_{Lave}(r_L + R_{sw_eq})}{L} R_i$ <p>Where average inductor current: $I_{Lave} = \frac{P_{out}}{V_{IN}\eta}$</p>	$\frac{V_{IN}}{L} R_i$
Compensation Ramp (m_c)	$1 + \frac{S_a}{S_n}$	$1 + \frac{S_a}{S_n}$
C _{out} ESR Zero (ω_{z1})	$\frac{1}{r_{CF} C_{OUT}}$	$\frac{1}{r_{CF} C_{OUT}}$
Right-Half-Plane Zero (ω_{z2})	$\frac{(1-D)^2}{L} \left(R_{OUT} - \frac{r_{CF} R_{OUT}}{r_{CF} + R_{OUT}} \right) - \frac{r_L}{L}$	$\frac{R_{OUT}}{M^2 L}$
Low Frequency Modulator Pole (ω_{p1})	$\frac{\frac{2}{R_{OUT}} + \frac{T_s}{LM^3} m_c}{C_{OUT}}$	$\frac{1}{R_{CF} C_{OUT}} \cdot \frac{2M-1}{M-1}$
High Frequency Modulator Pole (ω_{p2})	-	$2F_{SW} \left(\frac{1 - \frac{1}{M}}{D} \right)^2$
Sampling Double Pole (ω_n)	$\frac{\pi}{T_s}$	-
Sampling Quality Coefficient (Q_p)	$\frac{1}{\pi(m_c(1-D) - 0.5)}$	-
F_m	$\frac{1}{2M + \frac{R_{OUT}T_s}{LM^2} \left(\frac{1}{2} + \frac{S_a}{S_n} \right)}$	$\frac{1}{S_n m_c T_s}$
H_d	$\frac{\eta R_{OUT}}{R_i}$	$\frac{2V_{OUT}}{D} \cdot \frac{M-1}{2M-1}$
Control-Output Transfer Function (H_{ctrl_output}(f))	$F_m H_d \frac{\left(1 + j \frac{2\pi f}{\omega_{z1}} \right) \left(1 - j \frac{2\pi f}{\omega_{z2}} \right)}{\left(1 + j \frac{2\pi f}{\omega_{p1}} \right) \left(1 + j \frac{2\pi f}{\omega_{nQp}} + \left(j \frac{2\pi f}{\omega_n} \right)^2 \right)}$	$F_m H_d \frac{\left(1 + j \frac{2\pi f}{\omega_{z1}} \right) \left(1 - j \frac{2\pi f}{\omega_{z2}} \right)}{\left(1 + j \frac{2\pi f}{\omega_{p1}} \right) \left(1 + j \frac{2\pi f}{\omega_{p2}} \right)}$

Table 2. FLYBACK CCM AND DCM TRANSFER FUNCTION EXPRESSIONS

	CCM	DCM
Duty ratio (D)	$\frac{V_{OUT}}{V_{OUT} + NV_{IN}}$	$\frac{V_{OUT}}{NV_{IN}} \sqrt{2\tau_L}$ Where: $\tau_L = \frac{N^2 L_p}{T_s R_{OUT}}$
V_{OUT}/V_{IN} DC Conversion Ratio (M)	$\frac{N \cdot D}{1 - D}$	$\frac{N \cdot D}{\sqrt{2 \cdot \tau_L}}$
Inductor On-slope (S_n), V/s	$\frac{V_{IN}}{L_p} R_i$	$\frac{V_{IN}}{L_p} R_i$
Compensation Ramp (m_c)	$1 + \frac{S_a}{S_n}$	$1 + \frac{S_a}{S_n}$
C _{out} ESR Zero (ω_{z1})	$\frac{1}{r_{CF} C_{OUT}}$	$\frac{1}{r_{CF} C_{OUT}}$
Right-Half-Plane Zero (ω_{z2})	$\frac{(1 - D)^2 R_{OUT}}{D L_p N^2}$	$\frac{R_{OUT}}{N^2 L_p} \cdot \frac{1}{M(M + 1)}$
Modulator Pole (ω_{p1})	$\frac{\frac{D'^3}{2\tau_L} \left(1 + 2 \frac{S_a}{S_n}\right) + 1 + D}{R_{OUT} C_{OUT}}$	$\frac{2}{R_{OUT} C_{OUT}}$
ω_{p2}	-	$2F_{SW} \left(\frac{\frac{1}{D}}{1 + \frac{1}{M}}\right)^2$
F_m	$\frac{1}{\frac{D'^2}{\tau_L} \left(1 + 2 \frac{S_a}{S_n}\right) + 2M + 1}$	$\frac{1}{S_n m_c T_s}$
H_d	$\frac{R_{OUT}}{R_i N}$	$V_{IN} \sqrt{\frac{1}{2\tau_L}}$
Control-output Transfer Function (H_{ctrl_output}(f))	$F_m H_d \frac{\left(1 + j \frac{2\pi f}{\omega_{z1}}\right) \left(1 - j \frac{2\pi f}{\omega_{z2}}\right)}{\left(1 + j \frac{2\pi f}{\omega_{p1}}\right)}$	$F_m H_d \frac{\left(1 + j \frac{2\pi f}{\omega_{z1}}\right) \left(1 - j \frac{2\pi f}{\omega_{z2}}\right)}{\left(1 + j \frac{2\pi f}{\omega_{p1}}\right) \left(1 + j \frac{2\pi f}{\omega_{p2}}\right)}$

Once the desired cross-over frequency (*f_c*) gain adjustment and necessary phase boost are determined from the *H_{ctrl_output}(f)* gain and phase plots, the Table 3 equations may be used. It should be noted that minor compensation

component value adjustments may become necessary when $R_2 \leq \sim 10 \cdot R_{esd}$ as a result of approximations for determining components *R₂*, *C₁*, *C₂*.

Table 3. OTA COMPENSATION TRANSFER FUNCTION AND COMPENSATION VALUES

Desired OTA Gain at Cross-over Frequency f_c (G)	$\frac{\text{desired } G_{f_c, \text{gain, db}}}{10 \frac{20}{20}}$
Desired Phase Boost at Cross-over Frequency f_c (boost)	$\left(\theta_{\text{margin}} - \arg\left(H_{\text{ctrl_output}}(f_c)\right) \frac{180^\circ}{\pi} - 90^\circ \right) \frac{\pi}{180^\circ}$
Select OTA Compensation Zero to Coincide with Modulator Pole at f_{p1} (f_z)	$\frac{\omega_{p1e}}{2\pi}$
Resulting OTA High Frequency Pole Placement (f_p)	$\frac{f_z f_c + f_c^2 \tan(\text{boost})}{f_c - f_z \tan(\text{boost})}$
Compensation Resistor R_2	$\frac{f_p G}{f_p - f_z} \frac{V_{\text{OUT}}}{1.2 g_m} \frac{\sqrt{1 + \left(\frac{f_c}{f_p}\right)^2}}{\sqrt{1 + \left(\frac{f_z}{f_p}\right)^2}}$
Compensation Capacitor C_1	$\frac{1}{2\pi f_z R_2}$
Compensation Capacitor C_2	$\frac{1}{2\pi f_p G} \cdot \frac{R_{\text{low}} g_m}{R_{\text{low}} + R_1}$
OTA DC Gain (G_{0_OTA})	$\frac{R_{\text{low}}}{R_{\text{low}} + R_1} \cdot g_m \cdot R_0$
Low Frequency Zero (ω_{z1e})	$\frac{1}{2} \frac{(R_2 + R_{\text{esd}})}{R_2 R_{\text{esd}} C_2} \left[1 - \sqrt{1 - 4 \frac{R_2 R_{\text{esd}} C_2}{(R_2 + R_{\text{esd}})^2 C_1}} \right]$
High Frequency Zero (ω_{z2e})	$\frac{1}{2} \frac{(R_2 + R_{\text{esd}})}{R_2 R_{\text{esd}} C_2} \left[1 + \sqrt{1 - 4 \frac{R_2 R_{\text{esd}} C_2}{(R_2 + R_{\text{esd}})^2 C_1}} \right]$
Low Frequency Pole (ω_{p1e})	$\frac{1}{2} \frac{(R_0 + R_2 + R_{\text{esd}})}{R_2 (R_0 + R_{\text{esd}}) C_2} \left[1 - \sqrt{1 - 4 \frac{R_2 (R_0 + R_{\text{esd}}) C_2}{(R_0 + R_2 + R_{\text{esd}})^2 C_1}} \right]$
High Frequency Pole (ω_{p2e})	$\frac{1}{2} \frac{(R_0 + R_2 + R_{\text{esd}})}{R_2 (R_0 + R_{\text{esd}}) C_2} \left[1 + \sqrt{1 - 4 \frac{R_2 (R_0 + R_{\text{esd}}) C_2}{(R_0 + R_2 + R_{\text{esd}})^2 C_1}} \right]$
OTA Transfer Function ($G_{OTA}(f)$)	$-G_{0_OTA} \frac{\left(1 + j \frac{2\pi f}{\omega_{z1e}}\right) \left(1 + j \frac{2\pi f}{\omega_{z2e}}\right)}{\left(1 + j \frac{2\pi f}{\omega_{p1e}}\right) \left(1 + j \frac{2\pi f}{\omega_{p2e}}\right)}$

The open-loop-response in closed-loop form to verify the gain/phase margins may be obtained from the following expression.

$$T(f) = G_{OTA}(f) H_{\text{ctrl_output}}(f)$$

Low Voltage Operation

If the input voltage drops below the UVLO or MOSFET threshold voltage, another voltage may be used to power the

device. Simply connect the voltage you would like to boost to the inductor and connect the stable voltage to the VIN pin of the device. In boost configuration, the output of the converter can be used to power the device. In some cases it may be desirable to connect 2 sources to VIN pin, which can be accomplished simply by connecting each of the sources through a diode to the VIN pin.

PACKAGE DIMENSIONS

SOIC-8 NB
CASE 751-07
ISSUE AK

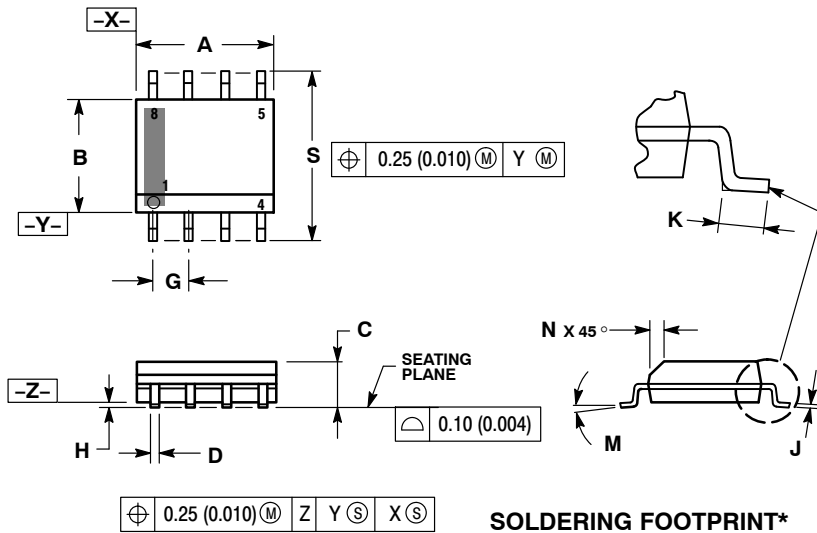

- NOTES:
1. DIMENSIONING AND TOLERANCING PER ANSI Y14.5M, 1982.
 2. CONTROLLING DIMENSION: MILLIMETER.
 3. DIMENSION A AND B DO NOT INCLUDE MOLD PROTRUSION.
 4. MAXIMUM MOLD PROTRUSION 0.15 (0.006) PER SIDE.
 5. DIMENSION D DOES NOT INCLUDE DAMBAR PROTRUSION. ALLOWABLE DAMBAR PROTRUSION SHALL BE 0.127 (0.005) TOTAL IN EXCESS OF THE D DIMENSION AT MAXIMUM MATERIAL CONDITION.
 6. 751-01 THRU 751-06 ARE OBSOLETE. NEW STANDARD IS 751-07.

DIM	MILLIMETERS		INCHES	
	MIN	MAX	MIN	MAX
A	4.80	5.00	0.189	0.197
B	3.80	4.00	0.150	0.157
C	1.35	1.75	0.053	0.069
D	0.33	0.51	0.013	0.020
G	1.27 BSC		0.050 BSC	
H	0.10	0.25	0.004	0.010
J	0.19	0.25	0.007	0.010
K	0.40	1.27	0.016	0.050
M	0°	8°	0°	8°
N	0.25	0.50	0.010	0.020
S	5.80	6.20	0.228	0.244

SOLDERING FOOTPRINT*

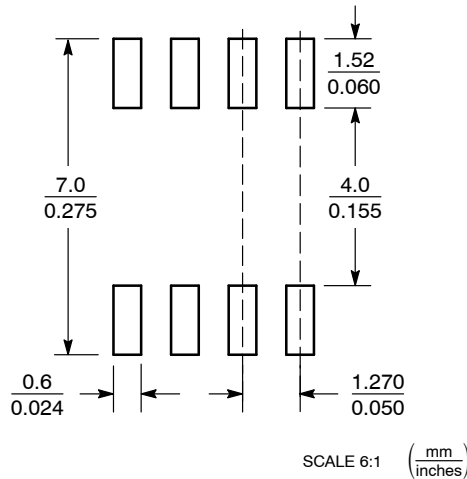

*For additional information on our Pb-Free strategy and soldering details, please download the ON Semiconductor Soldering and Mounting Techniques Reference Manual, SOLDERRM/D.

ON Semiconductor and are trademarks of Semiconductor Components Industries, LLC dba ON Semiconductor or its subsidiaries in the United States and/or other countries. ON Semiconductor owns the rights to a number of patents, trademarks, copyrights, trade secrets, and other intellectual property. A listing of ON Semiconductor's product/patent coverage may be accessed at www.onsemi.com/site/pdf/Patent-Marking.pdf. ON Semiconductor reserves the right to make changes without further notice to any products herein. ON Semiconductor makes no warranty, representation or guarantee regarding the suitability of its products for any particular purpose, nor does ON Semiconductor assume any liability arising out of the application or use of any product or circuit, and specifically disclaims any and all liability, including without limitation special, consequential or incidental damages. Buyer is responsible for its products and applications using ON Semiconductor products, including compliance with all laws, regulations and safety requirements or standards, regardless of any support or applications information provided by ON Semiconductor. "Typical" parameters which may be provided in ON Semiconductor data sheets and/or specifications can and do vary in different applications and actual performance may vary over time. All operating parameters, including "Typicals" must be validated for each customer application by customer's technical experts. ON Semiconductor does not convey any license under its patent rights nor the rights of others. ON Semiconductor products are not designed, intended, or authorized for use as a critical component in life support systems or any FDA Class 3 medical devices or medical devices with a same or similar classification in a foreign jurisdiction or any devices intended for implantation in the human body. Should Buyer purchase or use ON Semiconductor products for any such unintended or unauthorized application, Buyer shall indemnify and hold ON Semiconductor and its officers, employees, subsidiaries, affiliates, and distributors harmless against all claims, costs, damages, and expenses, and reasonable attorney fees arising out of, directly or indirectly, any claim of personal injury or death associated with such unintended or unauthorized use, even if such claim alleges that ON Semiconductor was negligent regarding the design or manufacture of the part. ON Semiconductor is an Equal Opportunity/Affirmative Action Employer. This literature is subject to all applicable copyright laws and is not for resale in any manner.

PUBLICATION ORDERING INFORMATION

LITERATURE FULFILLMENT:
Literature Distribution Center for ON Semiconductor
P.O. Box 5163, Denver, Colorado 80217 USA
Phone: 303-675-2175 or 800-344-3860 Toll Free USA/Canada
Fax: 303-675-2176 or 800-344-3867 Toll Free USA/Canada
Email: orderlit@onsemi.com

N. American Technical Support: 800-282-9855 Toll Free
USA/Canada
Europe, Middle East and Africa Technical Support:
Phone: 421 33 790 2910

ON Semiconductor Website: www.onsemi.com
Order Literature: <http://www.onsemi.com/orderlit>

For additional information, please contact your local Sales Representative



Компания «ЭлектроПласт» предлагает заключение долгосрочных отношений при поставках импортных электронных компонентов на взаимовыгодных условиях!

Наши преимущества:

- Оперативные поставки широкого спектра электронных компонентов отечественного и импортного производства напрямую от производителей и с крупнейших мировых складов;
- Поставка более 17-ти миллионов наименований электронных компонентов;
- Поставка сложных, дефицитных, либо снятых с производства позиций;
- Оперативные сроки поставки под заказ (от 5 рабочих дней);
- Экспресс доставка в любую точку России;
- Техническая поддержка проекта, помощь в подборе аналогов, поставка прототипов;
- Система менеджмента качества сертифицирована по Международному стандарту ISO 9001;
- Лицензия ФСБ на осуществление работ с использованием сведений, составляющих государственную тайну;
- Поставка специализированных компонентов (Xilinx, Altera, Analog Devices, Intersil, Interpoint, Microsemi, Aeroflex, Peregrine, Syfer, Eurofarad, Texas Instrument, Miteq, Cobham, E2V, MA-COM, Hittite, Mini-Circuits, General Dynamics и др.);

Помимо этого, одним из направлений компании «ЭлектроПласт» является направление «Источники питания». Мы предлагаем Вам помощь Конструкторского отдела:

- Подбор оптимального решения, техническое обоснование при выборе компонента;
- Подбор аналогов;
- Консультации по применению компонента;
- Поставка образцов и прототипов;
- Техническая поддержка проекта;
- Защита от снятия компонента с производства.



Как с нами связаться

Телефон: 8 (812) 309 58 32 (многоканальный)

Факс: 8 (812) 320-02-42

Электронная почта: org@eplast1.ru

Адрес: 198099, г. Санкт-Петербург, ул. Калинина, дом 2, корпус 4, литера А.