

S1D13719 Mobile Graphics Engine

February 2012

The S1D13719 is a Mobile Graphics Engine solution designed with support for the digital video revolution in mobile products. The S1D13719 contains an integrated dual port camera interface, hardware JPEG encoder/decoder and can be interfaced to an external MPEG codec. Seamlessly connecting to both direct and indirect CPU interfaces, it provides support for up to two LCD panels. The Mobile Graphics Engine supports all standard TFT panel types and many extended TFT types, eliminating the need for an external timing control IC. The S1D13719, with its 512K bytes of embedded SRAM and rich feature set, provides a low cost, low power, single chip solution to meet the demands of embedded markets requiring Digital Video, such as Mobile Communications devices and Palm-size PDAs.

Additionally, products requiring a rotated display can take advantage of the SwivelView™ feature which provides hardware rotation of the display memory transparent to the software application. The S1D13719 also provides support for “Picture-in-Picture Plus” (a variable size window with overlay functions). Higher performance is provided by the Hardware Acceleration Engine which provides 2D BitBLT functions.

The S1D13719 provides impressive support for cellular and other mobile solutions requiring Digital Video support. However, its impartiality to CPU type or operating system makes it an ideal display solution for a wide variety of applications.

■ FEATURES

- Embedded 512K byte SRAM Display Buffer
- Low Operating Voltage
- Direct and Indirect CPU interfaces
- Programmable resolutions and color depths
- Support for 2 panels (LCD2 must be RAM integrated)
- Support for RGB, Serial and Parallel I/F Panels
- Extended TFT interfaces including HR-TFT
- Internal PLL or digital clock input
- SD Memory Card interface
- Dual port Camera interface
- Fractional View and Capture hardware resizer, reduction from 1x to ½x size in 128 steps
- Fractional Zoom for YUV 4:2:2, expand from 1x to 2x size in 128 steps
- Hardware JPEG encoder/decoder
- YUV to RGB converter
- SwivelView™ (90°, 180°, 270° hardware rotation of displayed image)
 - (Patent # 5,734,875 - Patent # 5,956,049 - Patent #6,262,751)
- “Picture-in-Picture Plus”
- 2D Hardware Acceleration Engine
- Software Initiated Power Save Mode



■ SYSTEM BLOCK DIAGRAM

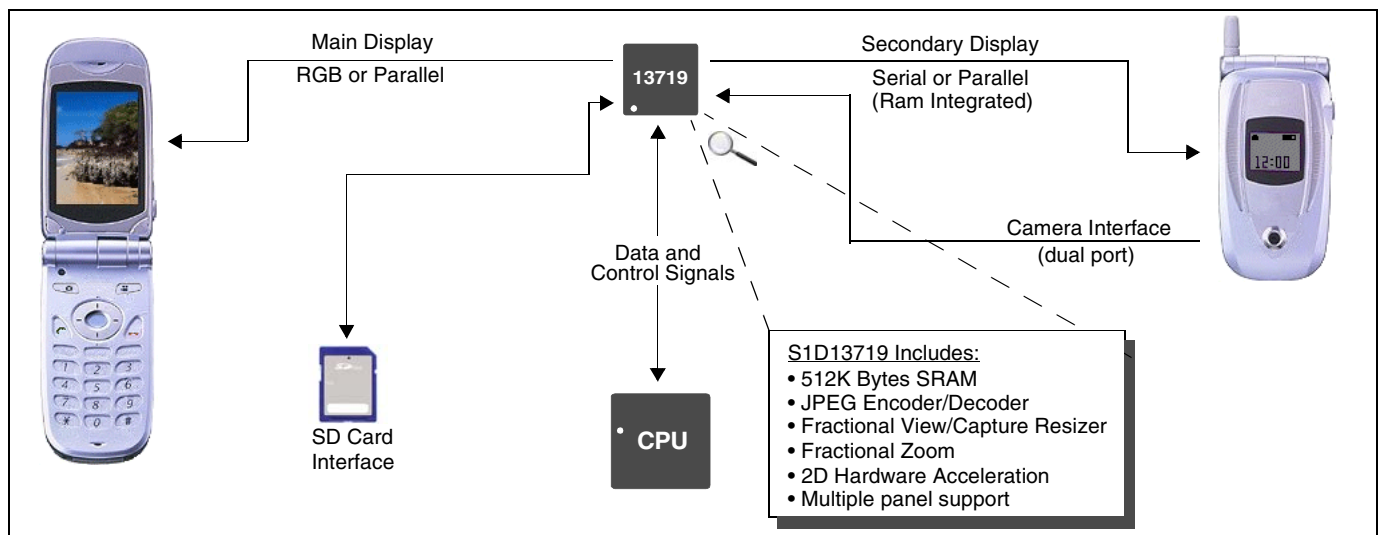

DESCRIPTION

Integrated Display Buffer

- 512K bytes of embedded SRAM
- Addressable as a single linear address space

CPU Interface

- 16-bit Generic Asynchronous CPU interface
- Direct and Indirect addressing

Panel Support

- Supports up to 2 LCD panels
- LCD1: 9/12/18/24-bit RGB panel
LCD2: 8/9-bit Serial Ram Integrated panel
- LCD1: 8/16/18/24-bit Parallel Ram Integrated panel
LCD2: 8/9-bit Serial Ram Integrated panel
- LCD1: 8/16/18/24-bit Parallel Ram Integrated panel
LCD2: 8/16/18/24-bit Parallel Ram Integrated panel
- LCD1: 9/12/18/24-bit RGB panel
LCD2: 8-bit Parallel Ram Integrated panel
- TFT, HR-TFT, Casio TFT, α -TFT, ND-TFD, and Extended TFT
- Typical resolution of:
up to 320x480 at 16 bpp
up to 320x240 at 32 bpp

Acceleration

- 2D BitBLT Engine
- SwivelView: 90°, 180°, 270° hardware rotation of displayed image
- Mirror Display: hardware "mirror" image of display

Display Features

- 8/16/32 bit-per-pixel (bpp) support
- Picture-in-Picture Plus: displays a variable size window overlaid over the background image
- Overlay Functions
- Pixel Doubling: doubles the effective resolution
- Video Invert: inverts display data

Digital Video

- Dual port Camera Interface (YUV 4:2:2)
- Hardware JPEG Encoder (YUV 4:2:2, 4:1:1, 4:2:0)
- Hardware JPEG Decoder (YUV 4:4:4, 4:2:2, 4:1:1, 4:2:0)
- YUV Display/Capture (YUV 4:2:2, 4:2:0)
- Memory Image JPEG Encode (YUV 4:2:2, 4:1:1, 4:2:0)
- View and Capture hardware resizer, reduction from 1x to 1/2x size in 128 steps with trimming functions
- Fractional Zoom for YUV 4:2:2, expand from 1x to 2x size in 128 steps
- YUV to RGB and RGB to YUV converters
- Support for external MPEG codec interface

Miscellaneous

- Internal PLL or digital clock input
- Software initiated power save mode
- CORE_{VDD} 1.8 volts and IO_{VDD} 3.0 volts
- PFBGA 180-pin package

CONTACT YOUR SALES REPRESENTATIVE FOR THESE COMPREHENSIVE DESIGN TOOLS

- S1D13719 Technical Documentation
- S1D13719 Evaluation Boards
- CPU Independent Software Utilities
- Royalty Free source level driver code



symbian
OS



Japan
Seiko Epson Corporation
IC International Sales Group
421-8, Hino, Hino-shi
Tokyo 191-8501, Japan
Tel: 042-587-5812
Fax: 042-587-5564
<http://www.epson.co.jp/>

Hong Kong
Epson Hong Kong Ltd.
20/F, Harbour Centre
25 Harbour Road
Wanchai, Hong Kong
Tel: 2585-4600
Fax: 2827-4346
<http://www.epson.com.hk/>

North America
Epson Electronics America, Inc.
214 Devcon Drive
San Jose, CA 95112, USA
Tel: (800) 228-3964
Fax: (408) 922-0238
<http://www.eea.epson.com/>

Europe
Epson Europe Electronics GmbH
Riesstrasse 15
80992 Munich, Germany
Tel: 089-14005-0
Fax: 089-14005-110
<http://www.epson-electronics.de/>

Taiwan
Epson Taiwan Technology & Trading Ltd.
14F, No. 7
Song Ren Road
Taipei 110
Tel: 02-8786-6688
Fax: 02-8786-6677
<http://www.epson.com.tw/>

Singapore
Epson Singapore Pte Ltd
1 HarbourFront Place #03-02
HarbourFront Tower One
Singapore, 098633
Tel: (65) 6586-5500
Fax: (65) 6271-3182
<http://www.epson.com.sg/>

© SEIKO EPSON CORPORATION 2004-2012. All rights reserved.
Information in this document is subject to change without notice. You may download and use this document, but only for your own use in evaluating Seiko Epson/EPSON products. You may not modify the document. Epson Research and Development, Inc. disclaims any representation that the contents of this document are accurate or current. The Programs/Technologies described in this document may contain material protected under U.S. and/or International Patent laws.
EPSON is a registered trademark of Seiko Epson Corporation. All other trademarks are the property of their respective owners.



Компания «ЭлектроПласт» предлагает заключение долгосрочных отношений при поставках импортных электронных компонентов на взаимовыгодных условиях!

Наши преимущества:

- Оперативные поставки широкого спектра электронных компонентов отечественного и импортного производства напрямую от производителей и с крупнейших мировых складов;
- Поставка более 17-ти миллионов наименований электронных компонентов;
- Поставка сложных, дефицитных, либо снятых с производства позиций;
- Оперативные сроки поставки под заказ (от 5 рабочих дней);
- Экспресс доставка в любую точку России;
- Техническая поддержка проекта, помощь в подборе аналогов, поставка прототипов;
- Система менеджмента качества сертифицирована по Международному стандарту ISO 9001;
- Лицензия ФСБ на осуществление работ с использованием сведений, составляющих государственную тайну;
- Поставка специализированных компонентов (Xilinx, Altera, Analog Devices, Intersil, Interpoint, Microsemi, Aeroflex, Peregrine, Syfer, Eurofarad, Texas Instrument, Miteq, Cobham, E2V, MA-COM, Hittite, Mini-Circuits, General Dynamics и др.);

Помимо этого, одним из направлений компании «ЭлектроПласт» является направление «Источники питания». Мы предлагаем Вам помощь Конструкторского отдела:

- Подбор оптимального решения, техническое обоснование при выборе компонента;
- Подбор аналогов;
- Консультации по применению компонента;
- Поставка образцов и прототипов;
- Техническая поддержка проекта;
- Защита от снятия компонента с производства.



Как с нами связаться

Телефон: 8 (812) 309 58 32 (многоканальный)

Факс: 8 (812) 320-02-42

Электронная почта: org@eplast1.ru

Адрес: 198099, г. Санкт-Петербург, ул. Калинина, дом 2, корпус 4, литера А.