



FDT SERIES ELEMENTS WITH LEAD ATTACHMENT

SPECIFICATIONS

- ◆ Piezo Film Technology
- ◆ Flexible Leads
- ◆ High Strain Output
- ◆ Film Thickness Options
- ◆ Lamination Options
- ◆ Solderable Connection Pins

The “F” in FDT Series stands for “Flexible Leads”. These are rectangle elements of Piezo film with silver ink screen printed electrodes. Rather than making the lead attachment near the sensor, the Piezo polymer tail extends from the active sensor area as flex circuit material with offset traces. This gives a very flat, flexible lead with a connector at the end.

The FDT elements are available in a variety of different sizes and thicknesses. They are available without a laminate (FDT), with a laminated (0.005” mylar) on one side (FLDT) or with tape release layer adhesive (FDT with adh) in the sensor area.

FEATURES

- ◆ Thin piezo film sensor
- ◆ Flexible leads give flat profile to the sensor
- ◆ Dynamic strain sensing with a high output
- ◆ Typical interface to a 1 or 10 M Ω input impedance
- ◆ Output Voltage (dependent on force applied) 10 mV to 100V

APPLICATIONS

- ◆ Sensing Direct Contact Force
- ◆ Recording Time of an Event
- ◆ Counting Number of Impact Events
- ◆ Measuring Impact Related Events
- ◆ Sensing Vibration using Cantilevered Beam
- ◆ Wakeup Switch
- ◆ Motion Detection

DIMENSIONS and PART NUMBERS

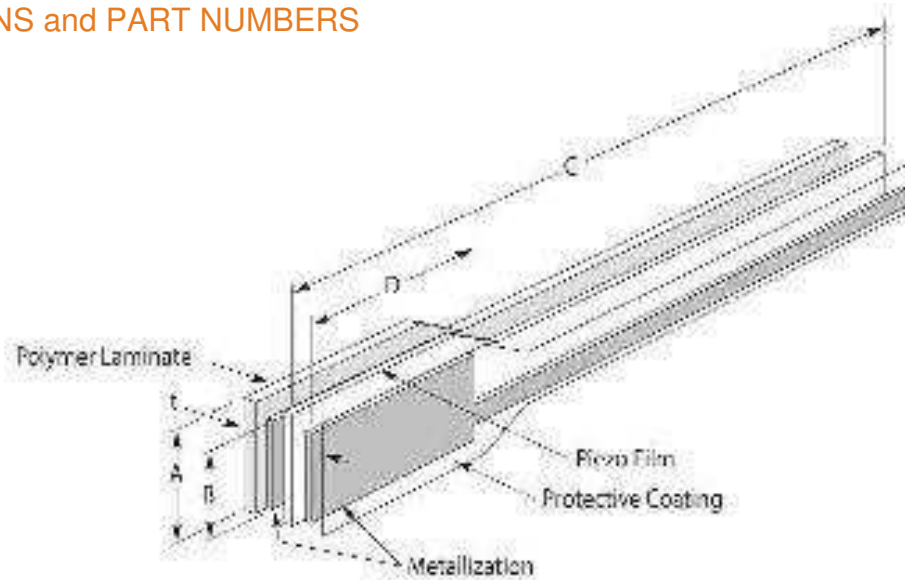

DIMENSION in INCHES (mm)

Model Number	Part Number	Film thickness	A Film	B Electrode	C Film	D Electrode	t (µm)	Cap (nF)
FDT1-028K	1-1002785-1	28 µm	.620 (16)	.485 (12)	9.25 (235)	1.16 (30)	55	1.37
FDT1-052K	2-1002785-1	52 µm	.620 (16)	.485 (12)	9.25 (235)	1.16 (30)	85	.740
FLDT1-028K	1-1002786-1	28 µm	.620 (16)	.485 (12)	9.25 (235)	1.16 (30)	205	1.37
FLDT1-052K	2-1002786-1	52 µm	.620 (16)	.485 (12)	9.25 (235)	1.16 (30)	230	.740
FDT1-028K w/adh-F	1001777	28 µm	.650 (17)	.485 (12)	5.51 (140)	1.18 (30)	125	1.37

The connector pins on the FDT sensors can be directly soldered to a PCB with a reasonable level of care. This component cannot withstand high temperatures (>80°C) and therefore soldering of the pins to a PCB must be done quickly. A heat sink clamped to the interface area between the film and the crimps will take the heat away from the film. Pre-tin the pins and then quickly solder them to the board. Do not allow the soldering iron to touch the film and do not use a dwell time of more than 5 seconds on the pins. Low temperature solder can also be used.

NORTH AMERICA

Measurement Specialties, Inc.,
a TE Connectivity Company
Tel: +1-800-522-6752
Email: customercare.dtm@te.com

EUROPE

MEAS Deutschland GmbH
a TE Connectivity Company
Tel: +49-800-440-5100
Email: customercare.dtm@te.com

ASIA

Measurement Specialties (China), Ltd.,
a TE Connectivity Company
Tel: +86 0400-820-6015
Email: customercare.chdu@te.com

TE.com/sensorsolutions

Measurement Specialties, Inc., a TE Connectivity company.

Measurement Specialties, TE Connectivity, TE Connectivity (logo) and EVERY CONNECTION COUNTS are trademarks. All other logos, products and/or company names referred to herein might be trademarks of their respective owners.

The information given herein, including drawings, illustrations and schematics which are intended for illustration purposes only, is believed to be reliable. However, TE Connectivity makes no warranties as to its accuracy or completeness and disclaims any liability in connection with its use. TE Connectivity's obligations shall only be as set forth in TE Connectivity's Standard Terms and Conditions of Sale for this product and in no case will TE Connectivity be liable for any incidental, indirect or consequential damages arising out of the sale, resale, use or misuse of the product. Users of TE Connectivity products should make their own evaluation to determine the suitability of each such product for the specific application.

© 2015 TE Connectivity Ltd. family of companies All Rights Reserved.



Компания «ЭлектроПласт» предлагает заключение долгосрочных отношений при поставках импортных электронных компонентов на взаимовыгодных условиях!

Наши преимущества:

- Оперативные поставки широкого спектра электронных компонентов отечественного и импортного производства напрямую от производителей и с крупнейших мировых складов;
- Поставка более 17-ти миллионов наименований электронных компонентов;
- Поставка сложных, дефицитных, либо снятых с производства позиций;
- Оперативные сроки поставки под заказ (от 5 рабочих дней);
- Экспресс доставка в любую точку России;
- Техническая поддержка проекта, помощь в подборе аналогов, поставка прототипов;
- Система менеджмента качества сертифицирована по Международному стандарту ISO 9001;
- Лицензия ФСБ на осуществление работ с использованием сведений, составляющих государственную тайну;
- Поставка специализированных компонентов (Xilinx, Altera, Analog Devices, Intersil, Interpoint, Microsemi, Aeroflex, Peregrine, Syfer, Eurofarad, Texas Instrument, Miteq, Cobham, E2V, MA-COM, Hittite, Mini-Circuits, General Dynamics и др.);

Помимо этого, одним из направлений компании «ЭлектроПласт» является направление «Источники питания». Мы предлагаем Вам помощь Конструкторского отдела:

- Подбор оптимального решения, техническое обоснование при выборе компонента;
- Подбор аналогов;
- Консультации по применению компонента;
- Поставка образцов и прототипов;
- Техническая поддержка проекта;
- Защита от снятия компонента с производства.



Как с нами связаться

Телефон: 8 (812) 309 58 32 (многоканальный)

Факс: 8 (812) 320-02-42

Электронная почта: org@eplast1.ru

Адрес: 198099, г. Санкт-Петербург, ул. Калинина, дом 2, корпус 4, литера А.