

Fixed Wirewound High Power Vitreous Resistors with Terminal Collars or Bands



FEATURES

- 10 W to 80 W at 25 °C
- NF C 93-214
- RB 13 x 70 RB 20 x 117
- High power up to 80 W at 25 °C
- High long term stability drift < 2.5 % after 5000 h
- Great mechanical strength
- Fire proof
- Environmental performance
- Thermal shock strength 0.5 % (100 % h at - 25 °C)
- Compliant to RoHS directive 2002/95/EC



The RW wirewound power resistors are extremely well suited to professional applications, where high power and excellent endurance are required. They meet all requirements of NF C 93-214 specifications and five sizes cover the power range from 10 W to 80 W. Non inductive types are available, by using the special RWNI winding. For higher power or extremely severe conditions of use, see the RWST series.

NF F 16101, 10/1988 and 16102, 04/1992: Not applicable (our parts are made of metallic and refractory materials).
NF C 93-214. Performances according to NF C 93-214.

DIMENSIONS in millimeters

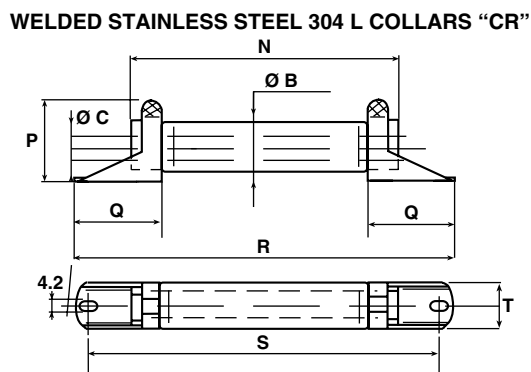
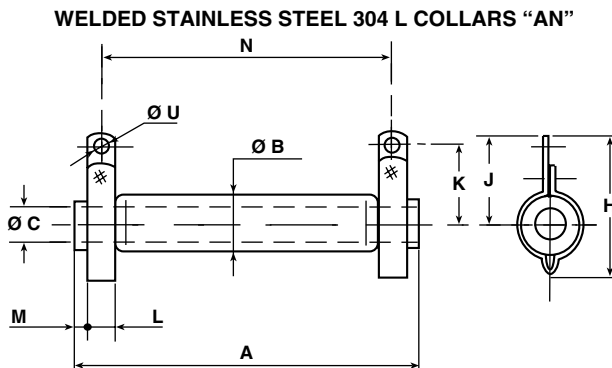
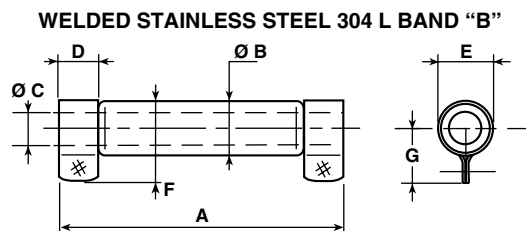

RW STYLE		8 x 34	10 x 50	13 x 70	16 x 94	20 x 117
CONNECTIONS	Collar	AN	AN	AN	AN	AN
	Collar	-	CR	CR	-	-
	Collar	-	-	CS	-	-
	Band	-	B	B	B	B
A ±2		34	50	70	94	117
Ø B max.		11.5	13	16	19.5	23
Ø C min.		4.1	5	5	9	9
D +0.5 +0		-	8	10.5	12	14
E		-	11 ± 0.5	14 ± 0.5	17.5 ± 0.5	21 ± 0.7
F max.		-	21	24.5	28	33
G		-	14 ± 0.5	16 ± 0.5	18 ± 0.5	21 ± 0.7
H		28 ± 1.0	31 ± 1.0	34 ± 1.0	38 ± 1.0	42 ± 1.5
J		19.5 ± 0.5	22 ± 0.5	24 ± 0.5	25 ± 0.5	28 ± 0.7
K		16 ± 0.5	18 ± 0.5	20 ± 0.5	21 ± 0.5	24 ± 0.7
L +0.5 +0		5	6.35	0.6	0.6	0.8
M ± 1.5		1	1.5	3.5	4	6
N ± 2		27	40	56	78	98
P ± 1		-	19.5	22.5	-	-
Q ± 0.5		-	19.5	20.5	-	-
R ± 2		-	72	91	-	-
S ± 2		-	62	81	-	-
T		-	12	15	-	-
Ø U		3.2	4.2	4.2	4.2	4.2

WELDED STAINLESS STEEL 304L COLLARS "CS"

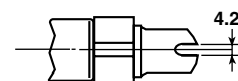



Fixed Wirewound High Power Vitreous Resistors
with Terminal Collars or Bands

Vishay Sfernice

MECHANICAL SPECIFICATIONS

Mechanical Protection	Enamel
Resistive Element	Ni-Cr wire
Connections	B band
	AN - CR - CS collars
Average Unit Weight	10 g to 100 g

ENVIRONMENTAL SPECIFICATIONS

Temperature Limits	- 55 °C + 450 °C
Climatic Category	- 55 °C/+ 200 °C/56 days

ELECTRICAL SPECIFICATIONS

Resistance Range	1 Ω to 68 kΩ (E12 preferred series value)
Resistance Tolerances Standard	± 5 %
Power Rating	10 W to 80 W at 25 °C
Temperature Coefficient	75 ppm/°C (typical)
Dielectric Strength	1000 V _{RMS} (AN collars)
Insulation Resistance	100 MΩ (500 V _{DC}) AN collars
Shelf Life	0.1 % year (typical)

PERFORMANCE

TESTS	CONDITIONS	REQUIREMENTS	TYPICAL VALUES AND DRIFTS
Short Time Overload	10 Pr during 5 s Voltage limited at < 5000 V current limited at 5 A	2 % or 0.05 Ω	0.5 %
Climatic Sequence	- 55 °C + 200 °C 5 cycles	3 % or 0.05 Ω Insulation resistance > 100 MΩ	0.5 %
Humidity (Steady State)	56 days 95 % relative humidity	2 % or 0.05 Ω Insulation resistance > 100 MΩ	0.5 %
Thermal Shock	Load at 100 % Pr followed by cold temp. exposure at - 55 °C	2 % or 0.05 Ω	0.5 %
Shock	Severity 50 9 shocks/each side	1 % or 0.05 Ω	0.25 %
Vibration	Severity 55B	1 % or 0.05 Ω	0.25 %
Terminal Strength	Collar AN Traction 40 N Band B Torque 60 Ncm	1 % or 0.05 Ω	0.5 %
Load Life	90'/30' cycle 1000 h at Pr 25 °C	5 %	1000 h 1.5 %
			5000 h 2.5 %

SPECIAL FEATURES

RW STYLE	8 x 34	10 x 50	13 x 70	16 x 94	20 x 117
Designation NF C 93-214	-	-	RB 13 x 70	-	RB 20 x 117
Power Rating at 25 °C	10 W	17 W	28 W	44 W	72 W
Maximum Power Rating at 25 °C	13 W	20 W	32 W	50 W	80 W
Ohmic Range (E12, E24 series)	1 Ω 10 kΩ	1 Ω 27 kΩ	2.2 Ω 56 kΩ	2.2 Ω 56 kΩ	2.7 Ω 68 kΩ
Limiting Element Voltage	300 V	450 V	650 V	900 V	1100 V
Critical Resistance	6.9 kΩ	10 kΩ	13.2 kΩ	16 kΩ	15.1 kΩ

NON INDUCTIVE WINDING

For high frequencies, low self induction resistors are available with special windings.
RWNI designation.

MODEL AND STYLE	RWNI 8 x 34	RWNI 10 x 50	RWNI 13 x 70	RWNI 16 x 94	RWNI 20 x 117
Ohmic Range	4.7 Ω 100 Ω	4.7 Ω 220 Ω	4.7 Ω 620 Ω	10 Ω 1.2 kΩ	10 Ω 2.2 kΩ

POWER RATING CHART



TEMPERATURE RISE



MARKING

SFERNICE trademark, model, style, NF style (if applicable) nominal resistance (in Ω), tolerance (in %), manufacturing date.

ORDERING INFORMATION								
RW	20 x 117	NI		AN	68 Ω	$\pm 5\%$	B020	e
MODEL	STYLE	NON-INDUCTIVE WINDING	SPECIAL DESIGN	CONNECTIONS	OHMIC VALUE	TOLERANCE	PACKAGING	LEAD (Pb)-FREE
		Optional	Optional		Custom items are subject to extra-charge and min. order. Please see price list.			



GLOBAL PART NUMBER INFORMATION																		
R	W	1	6	X	9	4	A		2	0	3	J	B	0	0			
GLOBAL MODEL	SIZE	LEADS	OPTION	OHMIC VALUE				TOLERANCE	PACKAGING	SPECIAL								
RW	8X34 10X50 13X70 16X94 20117	A = AN B = B C = CS D = CR	N = Non inductive winding	<p>The first two digits are significant figures and the last digit specifies the number of zeros to follow. R designates decimal point.</p> <p>203 = 20 kΩ 471 = 470 Ω 48R = 48.7 Ω R01 = 0.01 Ω</p>				J = 5.0 %	<p>Box: BA25 BA25NA BO20 BO20NA BO30 BO30NA BO40 BO40NA BO50 BO50NA</p>	As applicable. Example: BC1								



Disclaimer

All product specifications and data are subject to change without notice.

Vishay Intertechnology, Inc., its affiliates, agents, and employees, and all persons acting on its or their behalf (collectively, "Vishay"), disclaim any and all liability for any errors, inaccuracies or incompleteness contained herein or in any other disclosure relating to any product.

Vishay disclaims any and all liability arising out of the use or application of any product described herein or of any information provided herein to the maximum extent permitted by law. The product specifications do not expand or otherwise modify Vishay's terms and conditions of purchase, including but not limited to the warranty expressed therein, which apply to these products.

No license, express or implied, by estoppel or otherwise, to any intellectual property rights is granted by this document or by any conduct of Vishay.

The products shown herein are not designed for use in medical, life-saving, or life-sustaining applications unless otherwise expressly indicated. Customers using or selling Vishay products not expressly indicated for use in such applications do so entirely at their own risk and agree to fully indemnify Vishay for any damages arising or resulting from such use or sale. Please contact authorized Vishay personnel to obtain written terms and conditions regarding products designed for such applications.

Product names and markings noted herein may be trademarks of their respective owners.



Компания «ЭлектроПласт» предлагает заключение долгосрочных отношений при поставках импортных электронных компонентов на взаимовыгодных условиях!

Наши преимущества:

- Оперативные поставки широкого спектра электронных компонентов отечественного и импортного производства напрямую от производителей и с крупнейших мировых складов;
- Поставка более 17-ти миллионов наименований электронных компонентов;
- Поставка сложных, дефицитных, либо снятых с производства позиций;
- Оперативные сроки поставки под заказ (от 5 рабочих дней);
- Экспресс доставка в любую точку России;
- Техническая поддержка проекта, помощь в подборе аналогов, поставка прототипов;
- Система менеджмента качества сертифицирована по Международному стандарту ISO 9001;
- Лицензия ФСБ на осуществление работ с использованием сведений, составляющих государственную тайну;
- Поставка специализированных компонентов (Xilinx, Altera, Analog Devices, Intersil, Interpoint, Microsemi, Aeroflex, Peregrine, Syfer, Eurofarad, Texas Instrument, Miteq, Cobham, E2V, MA-COM, Hittite, Mini-Circuits, General Dynamics и др.);

Помимо этого, одним из направлений компании «ЭлектроПласт» является направление «Источники питания». Мы предлагаем Вам помощь Конструкторского отдела:

- Подбор оптимального решения, техническое обоснование при выборе компонента;
- Подбор аналогов;
- Консультации по применению компонента;
- Поставка образцов и прототипов;
- Техническая поддержка проекта;
- Защита от снятия компонента с производства.



Как с нами связаться

Телефон: 8 (812) 309 58 32 (многоканальный)

Факс: 8 (812) 320-02-42

Электронная почта: org@eplast1.ru

Адрес: 198099, г. Санкт-Петербург, ул. Калинина, дом 2, корпус 4, литера А.