



## Features

- 0402 and 0603 package options
- Rated for IEC 61000-4-2, for applications requiring up to 18 V DC
- Withstands multiple ESD strikes
- Low capacitance and leakage currents for invisible load protection
- Tape and reel packaging

## ChipGuard® MLE Series Varistor ESD Clamp Protectors

### Description

The ChipGuard® CG0402MLE and CG0603MLE Series have been designed to provide high frequency attenuation, thereby providing suppression and filtering in a single device. The MLE family also offers protection to ESD standards such as IEC61000-4-2 for applications requiring up to 18 V DC and is available in the industry standard 0603 and 0402 type leadless surface mount packaging.

### Electrical Characteristics @ 25 °C (unless otherwise noted)

Model	Continuous Operating Voltage			Clamping Voltage	Off-state Current					Capacitance
	$V_{rms}$ (V)	$V_{DC}$ (V)		$V_{CLAMP}$ (V)	$I_L$ ( $\mu A$ )					$C_p$ (pF)
	Max.	Typ.	Max.	Typ.	Max.					Max.
				1 A @ 8/20 $\mu s$	3.5 V	5.5 V	9 V	12 V	18 V	1 $V_{rms}$ @ 1 MHz
CG0402MLE-18G	8.5	12	18	100	0.3	0.4	0.5	1	10	9
CG0603MLE-18E	8.5	12	18	60	0.3	0.4	0.5	1	10	50

### Environmental Characteristics

Operating Temperature ...-55 °C to +125 °C  
 Storage Temperature.....-55 °C to +125 °C  
 Response Time.....<1 ns  
 Standard..... IEC 61000-4-2 Level 4

These products are RoHS compliant. There is some lead contained within the glass of the ceramic. This is acceptable under exemption no. 5 of the RoHS directive (DIRECTIVE 2002/95/EC OF THE EUROPEAN PARLIAMENT AND OF THE COUNCIL of 27 January 2003 on the restriction of the use of certain hazardous substances in electrical and electronic equipment).

### Schematic

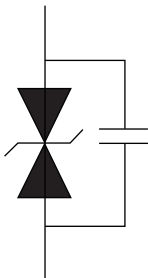

### Surge Withstand Ratings

Model	Peak Current 8/20 $\mu s$ (Max.)	Peak Current @ 8 kV (Max.)
CG0402MLE-18G	15 A	30 A
CG0603MLE-18E	20 A	45 A

### Voltage-Current Characteristics

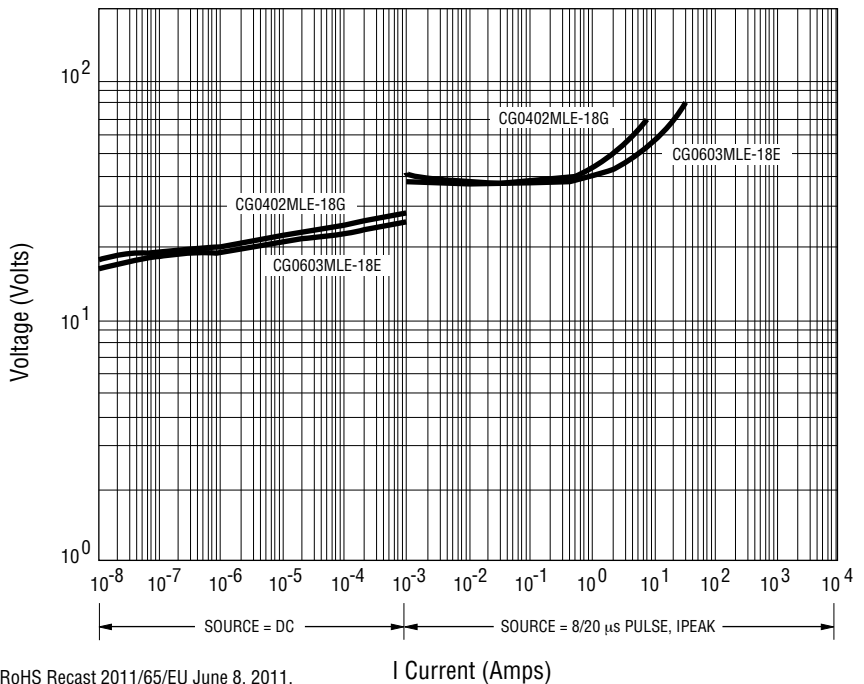

\*RoHS Directive 2002/95/EC Jan. 27, 2003 including annex and RoHS Recast 2011/65/EU June 8, 2011. Specifications are subject to change without notice. Customers should verify actual device performance in their specific applications.

# ChipGuard® MLE Series Varistor ESD Clamp Protectors

# BOURNS®

## Product Dimensions

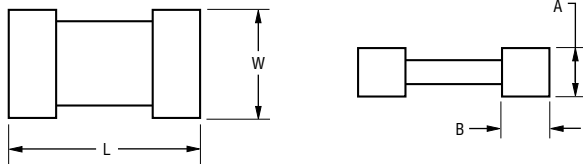

DIMENSIONS:  $\frac{\text{MM}}{\text{(INCHES)}}$

## Recommended Pad Layout

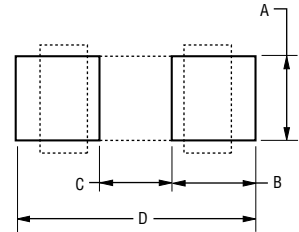

Dimension	CG0402MLE Series	CG0603MLE Series
L	$1.00 \pm 0.15$ (0.04 ± 0.006)	$1.60 \pm 0.20$ (0.064 ± 0.008)
W	$0.50 \pm 0.10$ (0.02 ± 0.004)	$0.80 \pm 0.20$ (0.032 ± 0.008)
A	$0.50 \pm 0.10$ (0.02 ± 0.004)	$0.80 \pm 0.20$ (0.032 ± 0.008)
B	$0.25 \pm 0.15$ (0.10 ± 0.006)	$0.30 \pm 0.20$ (0.012 ± 0.008)

Dim.	CG0402MLE Series	CG0603MLE Series
A	$0.51$ (0.020)	$0.76$ (0.030)
B	$0.61$ (0.024)	$1.02$ (0.040)
C	$0.51$ (0.020)	$0.50$ (0.020)
D	$1.70$ (0.067)	$2.54$ (0.100)

## Solder Reflow Recommendations

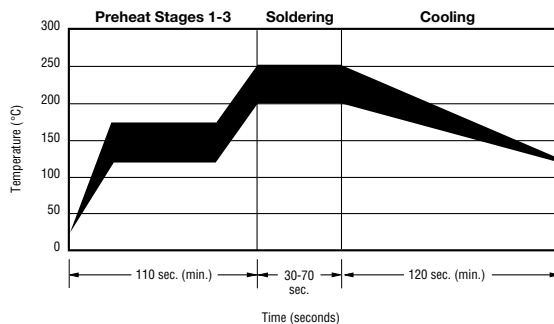

A	Stage 1 Preheat	Ambient to Preheating Temperature	30 s to 60 s
B	Stage 2 Preheat	140 °C to 160 °C	60 s to 120 s
C	Stage 3 Preheat	Preheat to 200 °C	20 s to 40 s
D	Main Heating	200 °C 210 °C 220 °C 230 °C 240 °C	60 s to 70 s 55 s to 65 s 50 s to 60 s 40 s to 50 s 30 s to 40 s
E	Cooling	200 °C to 100 °C	1 °C/s to 4 °C/s

- This product can be damaged by rapid heating, cooling or localized heating.
- Heat shocks should be avoided. Preheating and gradual cooling recommended.
- Excessive solder can damage the device. Print solder thickness of 150 to 200 um recommended.
- Solder gun tip temperature should be kept below 280 °C and should not touch the device directly. Contact should be less than 3 seconds. A solder gun under 30 watts is recommended.

## How to Order

### CG 0n0n MLE - 18 x

ChipGuard® Product Designator \_\_\_\_\_

Package Option \_\_\_\_\_

0402 = 0402 Package      0603 = 0603 Package

Multilayer Series Designator \_\_\_\_\_

Operating Voltage \_\_\_\_\_

18 = 18 V

Tape & Reel Packaging \_\_\_\_\_

E = 4,000 pcs. per reel (0603 package)      G = 10,000 pcs. per reel (0402 package)

Ni barrier terminations are standard on all ChipGuard® part numbers.

# ChipGuard® MLE Series Varistor ESD Clamp Protectors

**BOURNS®**

## Packaging Dimensions

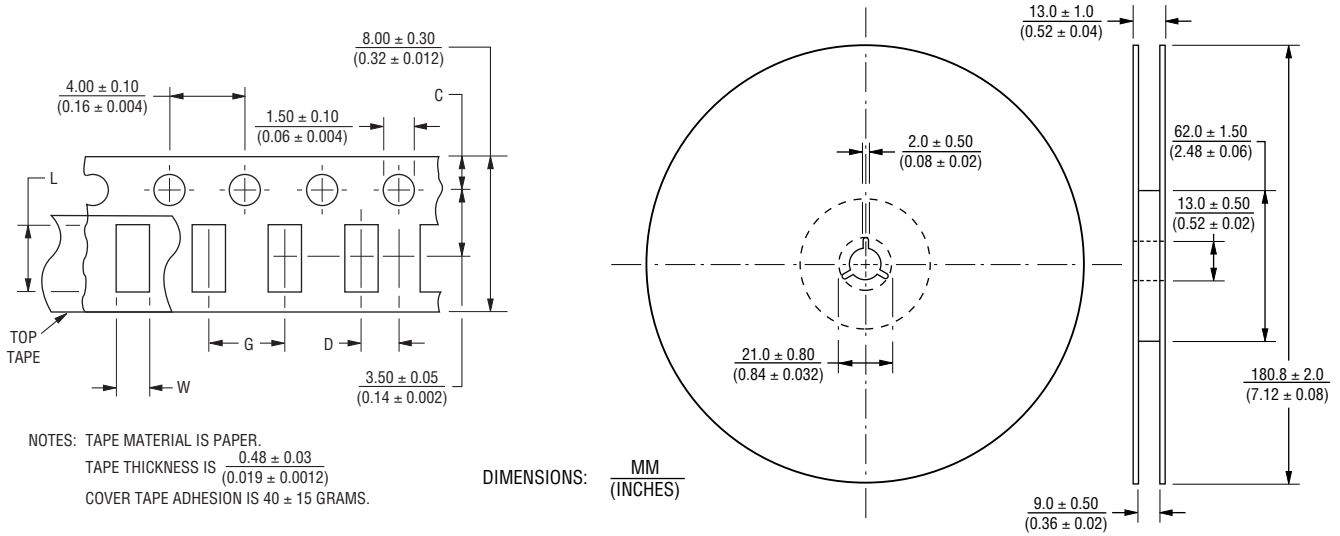

Dimension	CG0402MLE Series	CG0603MLE Series
C	$\frac{1.75 \pm 0.05}{(0.04 \pm 0.002)}$	$\frac{1.75 \pm 0.10}{(0.04 \pm 0.004)}$
D	$\frac{2.00 \pm 0.02}{(0.08 \pm 0.0008)}$	$\frac{2.00 \pm 0.05}{(0.08 \pm 0.002)}$
L	$\frac{1.19 \pm 0.05}{(0.047 \pm 0.002)}$	$\frac{1.80 \pm 0.20}{(0.072 \pm 0.008)}$
W	$\frac{0.69 \pm 0.05}{(0.027 \pm 0.002)}$	$\frac{0.90 \pm 0.20}{(0.036 \pm 0.008)}$
G	$\frac{2.0 \pm 0.05}{(0.08 \pm 0.002)}$	$\frac{4.0 \pm 0.05}{(0.16 \pm 0.002)}$

**BOURNS®**

Asia-Pacific: Tel: +886-2 2562-4117 • Fax: +886-2 2562-4116

Europe: Tel: +41-41 768 5555 • Fax: +41-41 768 5510

The Americas: Tel: +1-951 781-5500 • Fax: +1-951 781-5700

[www.bourns.com](http://www.bourns.com)

REV. I 09/12

Specifications are subject to change without notice.  
Customers should verify actual device performance in their specific applications.



Компания «ЭлектроПласт» предлагает заключение долгосрочных отношений при поставках импортных электронных компонентов на взаимовыгодных условиях!

Наши преимущества:

- Оперативные поставки широкого спектра электронных компонентов отечественного и импортного производства напрямую от производителей и с крупнейших мировых складов;
- Поставка более 17-ти миллионов наименований электронных компонентов;
- Поставка сложных, дефицитных, либо снятых с производства позиций;
- Оперативные сроки поставки под заказ (от 5 рабочих дней);
- Экспресс доставка в любую точку России;
- Техническая поддержка проекта, помощь в подборе аналогов, поставка прототипов;
- Система менеджмента качества сертифицирована по Международному стандарту ISO 9001;
- Лицензия ФСБ на осуществление работ с использованием сведений, составляющих государственную тайну;
- Поставка специализированных компонентов (Xilinx, Altera, Analog Devices, Intersil, Interpoint, Microsemi, Aeroflex, Peregrine, Syfer, Eurofarad, Texas Instrument, Miteq, Cobham, E2V, MA-COM, Hittite, Mini-Circuits, General Dynamics и др.);

Помимо этого, одним из направлений компании «ЭлектроПласт» является направление «Источники питания». Мы предлагаем Вам помощь Конструкторского отдела:

- Подбор оптимального решения, техническое обоснование при выборе компонента;
- Подбор аналогов;
- Консультации по применению компонента;
- Поставка образцов и прототипов;
- Техническая поддержка проекта;
- Защита от снятия компонента с производства.



#### Как с нами связаться

**Телефон:** 8 (812) 309 58 32 (многоканальный)

**Факс:** 8 (812) 320-02-42

**Электронная почта:** [org@eplast1.ru](mailto:org@eplast1.ru)

**Адрес:** 198099, г. Санкт-Петербург, ул. Калинина, дом 2, корпус 4, литера А.