

Development Kit DK-S124 v2.0

User's Manual: Hardware

Renesas Synergy™ Platform

All information contained in these materials, including products and product specifications, represents information on the product at the time of publication and is subject to change by Renesas Electronics Corp. without notice. Please review the latest information published by Renesas Electronics Corp. through various means, including the Renesas Electronics Corp. website (<http://www.renesas.com>).

Notice

1. Descriptions of circuits, software and other related information in this document are provided only to illustrate the operation of semiconductor products and application examples. You are fully responsible for the incorporation of these circuits, software, and information in the design of your equipment. Renesas Electronics assumes no responsibility for any losses incurred by you or third parties arising from the use of these circuits, software, or information.
2. Renesas Electronics has used reasonable care in preparing the information included in this document, but Renesas Electronics does not warrant that such information is error free. Renesas Electronics assumes no liability whatsoever for any damages incurred by you resulting from errors in or omissions from the information included herein.
3. Renesas Electronics does not assume any liability for infringement of patents, copyrights, or other intellectual property rights of third parties by or arising from the use of Renesas Electronics products or technical information described in this document. No license, express, implied or otherwise, is granted hereby under any patents, copyrights or other intellectual property rights of Renesas Electronics or others.
4. You should not alter, modify, copy, or otherwise misappropriate any Renesas Electronics product, whether in whole or in part. Renesas Electronics assumes no responsibility for any losses incurred by you or third parties arising from such alteration, modification, copy or otherwise misappropriation of Renesas Electronics product.
5. Renesas Electronics products are classified according to the following two quality grades: "Standard" and "High Quality". The recommended applications for each Renesas Electronics product depends on the product's quality grade, as indicated below.
"Standard": Computers; office equipment; communications equipment; test and measurement equipment; audio and visual equipment; home electronic appliances; machine tools; personal electronic equipment; and industrial robots etc.
"High Quality": Transportation equipment (automobiles, trains, ships, etc.); traffic control systems; anti-disaster systems; anti-crime systems; and safety equipment etc.

Renesas Electronics products are neither intended nor authorized for use in products or systems that may pose a direct threat to human life or bodily injury (artificial life support devices or systems, surgical implantations etc.), or may cause serious property damages (nuclear reactor control systems, military equipment etc.). You must check the quality grade of each Renesas Electronics product before using it in a particular application. You may not use any Renesas Electronics product for any application for which it is not intended. Renesas Electronics shall not be in any way liable for any damages or losses incurred by you or third parties arising from the use of any Renesas Electronics product for which the product is not intended by Renesas Electronics.
6. You should use the Renesas Electronics products described in this document within the range specified by Renesas Electronics, especially with respect to the maximum rating, operating supply voltage range, movement power voltage range, heat radiation characteristics, installation and other product characteristics. Renesas Electronics shall have no liability for malfunctions or damages arising out of the use of Renesas Electronics products beyond such specified ranges.
7. Although Renesas Electronics endeavors to improve the quality and reliability of its products, semiconductor products have specific characteristics such as the occurrence of failure at a certain rate and malfunctions under certain use conditions. Further, Renesas Electronics products are not subject to radiation resistance design. Please be sure to implement safety measures to guard them against the possibility of physical injury, and injury or damage caused by fire in the event of the failure of a Renesas Electronics product, such as safety design for hardware and software including but not limited to redundancy, fire control and malfunction prevention, appropriate treatment for aging degradation or any other appropriate measures. Because the evaluation of microcomputer software alone is very difficult, please evaluate the safety of the final products or systems manufactured by you.
8. Please contact a Renesas Electronics sales office for details as to environmental matters such as the environmental compatibility of each Renesas Electronics product. Please use Renesas Electronics products in compliance with all applicable laws and regulations that regulate the inclusion or use of controlled substances, including without limitation, the EU RoHS Directive. Renesas Electronics assumes no liability for damages or losses occurring as a result of your noncompliance with applicable laws and regulations.
9. Renesas Electronics products and technology may not be used for or incorporated into any products or systems whose manufacture, use, or sale is prohibited under any applicable domestic or foreign laws or regulations. You should not use Renesas Electronics products or technology described in this document for any purpose relating to military applications or use by the military, including but not limited to the development of weapons of mass destruction. When exporting the Renesas Electronics products or technology described in this document, you should comply with the applicable export control laws and regulations and follow the procedures required by such laws and regulations.
10. It is the responsibility of the buyer or distributor of Renesas Electronics products, who distributes, disposes of, or otherwise places the product with a third party, to notify such third party in advance of the contents and conditions set forth in this document, Renesas Electronics assumes no responsibility for any losses incurred by you or third parties as a result of unauthorized use of Renesas Electronics products.
11. This document may not be reproduced or duplicated in any form, in whole or in part, without prior written consent of Renesas Electronics.
12. Please contact a Renesas Electronics sales office if you have any questions regarding the information contained in this document or Renesas Electronics products, or if you have any other inquiries.

(Note 1) "Renesas Electronics" as used in this document means Renesas Electronics Corporation and also includes its majority-owned subsidiaries.

(Note 2) "Renesas Electronics product(s)" means any product developed or manufactured by or for Renesas Electronics.

Precautions

This Renesas Synergy™ Development Kit is only intended for use in a laboratory environment under ambient temperature and humidity conditions. A safe separation distance should be used between this and any sensitive equipment. Its use outside the laboratory, classroom, study area or similar such area invalidates conformity with the protection requirements of the Electromagnetic Compatibility Directive and could lead to prosecution.

The product generates, uses, and can radiate radio frequency energy and may cause harmful interference to radio communications. However, there is no guarantee that interference will not occur in a particular installation. If this equipment causes harmful interference to radio or television reception, which can be determined by turning the equipment off or on, you are encouraged to try to correct the interference by one or more of the following measures:

- Ensure attached cables do not lie across the equipment.
- Reorient the receiving antenna.
- Increase the distance between the equipment and the receiver.
- Connect the equipment into an outlet on a circuit different from that which the receiver is connected.
- Power down the equipment when not in use.
- Consult the dealer or an experienced radio/TV technician for help.

NOTE: It is recommended that wherever possible shielded interface cables are used.

The product is potentially susceptible to certain EMC phenomena. To mitigate against them it is recommended that the following measures be undertaken:

- The user is advised that mobile phones should not be used within 10m of the product when in use.
- The user is advised to take ESD precautions when handling the equipment.

The Renesas Synergy™ Development Kit does not represent an ideal reference design for an end product and does not fulfill the regulatory standards for an end product.

Table of Contents

Chapter 1 Overview 5

1.1	Purpose	5
1.2	In the box	6
1.3	Environmental Characteristics	6
1.4	Physical Characteristics	7
1.5	Block diagram.....	8
1.6	Hardware features	9
1.6.1	Main Board	9
1.6.1.1	MCU and Board Memory	9
1.6.1.2	Power	9
1.6.1.3	I/O Features	9
1.6.1.4	Programming and Debug Features	10
1.6.2	RSK PMOD Display Board.....	10
1.7	Usage Models.....	10
1.8	Hardware Versions.....	10
1.9	Resources.....	10

Chapter 2 Getting Started 11

2.1	Powering the DK-S124	11
2.2	See the Demo.....	12

Chapter 3 Power Supplies 13

3.1	Power supply.....	13
3.2	Power-up behavior	13
3.3	Battery supply configuration	13
3.4	+5-V Main Voltage Rail.....	13
3.5	3.3-V Main Power Subsystem	14
3.6	Power LED	14
3.7	Power Budgets	15
3.8	Microcontroller Current.....	16
3.9	Battery Current	16

Chapter 4 Components 17

4.1	RSK PMOD Display Board.....	17
4.2	USB Cable.....	17
4.3	Plug, 3.5-mm-Pitch, 8-Position, Screw Terminals	17
4.4	Peripheral Devices	17
4.5	CR2032 Lithium Battery	18
4.6	External Power Supply	18

Chapter 5 Board Layout 19

Chapter 6 Configuration..... 21

6.1	MCU Boot Configuration Jumper	21
6.2	Battery and 5V Power Source Selection Jumpers.....	21
6.3	RS-232/485 Transceiver Configuration	22

Chapter 7 Connectivity 24

7.1	Connectors.....	24
7.1.1	5-V Power Barrel Jack	24
7.1.2	USB Device	24
7.1.3	RS-232/485 and CAN	24
7.1.4	Stereo Headphone Jack	26
7.1.5	J-Link USB and Power	26
7.1.6	S124 Programming and Debug	27
7.1.7	J-Link JTAG Programming and Debug..	27
7.1.8	Shield-Style Header Connection	28
7.1.9	Seeed Grove I2C Interface	30
7.1.10	SPI&I2C Interface	31
7.1.11	PMOD Interface	31
7.2	Human-Machine Interface.....	34
7.2.1	User Touch Buttons	34
7.2.2	User Touch Slider	34
7.2.3	User Push-Button Switches	35
7.2.4	User LEDs (3).....	35
7.2.5	User Potentiometer	36
7.2.6	Reset Push-Button Switch	36
7.3	Main Board Devices	36
7.3.1	Serial Flash Memory	36
7.3.2	C-Max CMM-9301-V4.4	37
7.3.3	Maxim MAX9814 with MEMS microphone	37
7.3.4	Avago ADPS-9005	37
7.3.5	Analog Devices TMP35	37
7.3.6	Bosch BMA250E.....	37

Chapter 8 Glossary..... 39

8.1	Abbreviations and Acronyms.....	39
8.2	Port Numbering	40

Chapter 1 Overview

1.1 Purpose

The DK-S124 is a development kit for the Renesas Synergy™ S124 microcontroller in a LQFP64 package. The DK-S124 is primarily intended for software and hardware developers to develop firmware, experiment, and evaluate the I/O features of the S124 on the DK-S124 prior to development of their own customized hardware.

The DK-S124 contains several communications ports, including Bluetooth Low Energy, CAN, RS-232/RS-485, SPI, I2C, and USB Device. The board includes a PMOD™ connector and a Grove I2C connector (connector for easy-to-use Seeed Grove modules), for external prototyping modules from [Digilent](http://digilent.com) and other vendors.

For HMI interface examples, the DK-S124 include stereo headphone output, microphone input, touch buttons and a touch bar, two user-programmable push-buttons, three user programmable LEDs, a thumb-wheel potentiometer, light sensor, temperature sensor, and 3-axis accelerometer.

Several test points are located around the board, and jumpers are provided for measurements and configuration.

The DK-S124 is supported by both the e² studio from Renesas and the IAR embedded workbench for Synergy.

For more information on the Synergy DK-S124, visit the Synergy website: <http://renessasynergy.com/>.

Figure 1: DK-S124 main board and LCD board

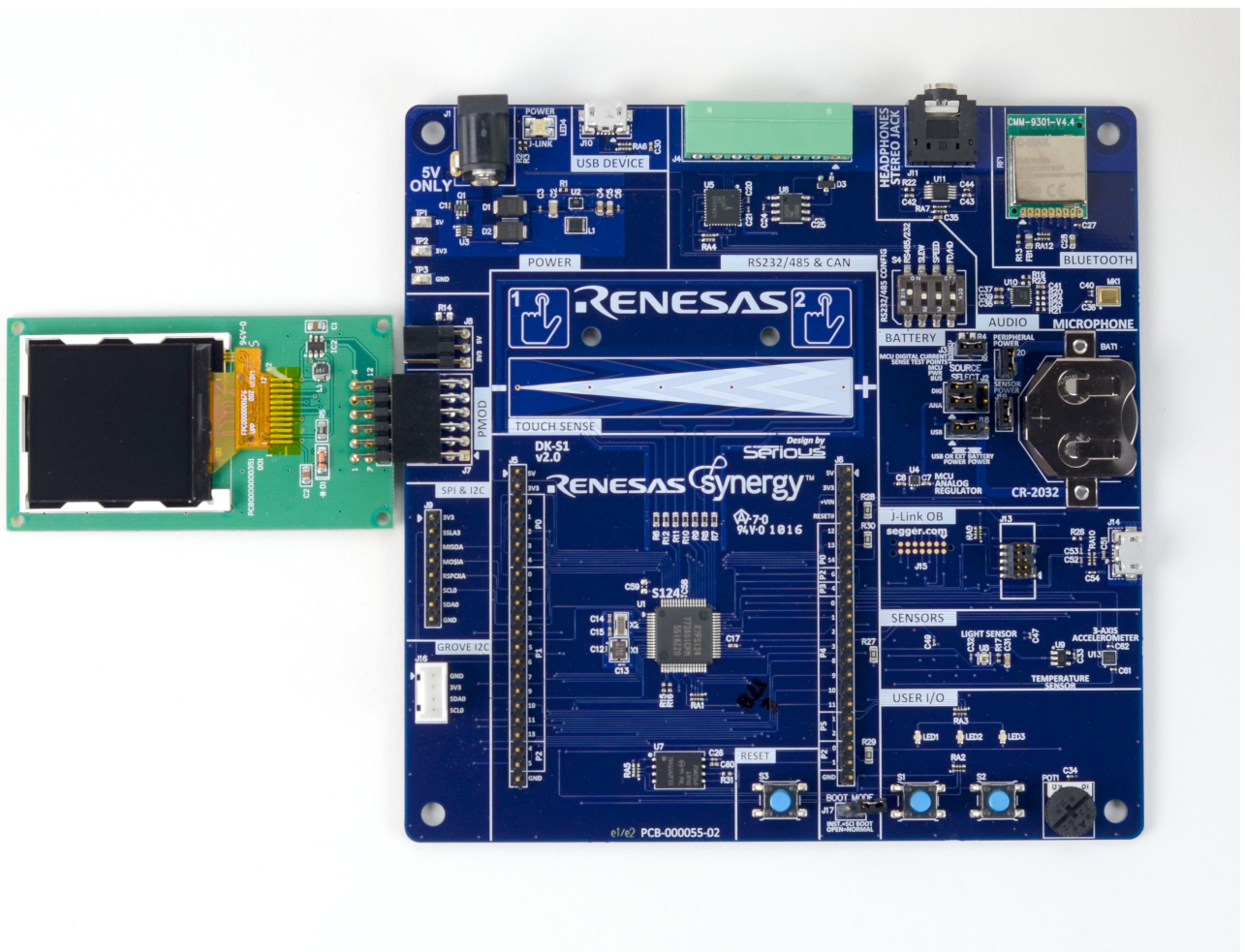

1.2 In the box

The following components are included in the DK-S124:

- DK-S124 Main Board with installed acrylic overlay for the touch buttons and touch slider, and installed bumper feet
- 8 shunt-jumpers for 0.1" headers on the DK-S124
- One RSK PMOD Display Board
- One three-foot USB cable Type-A connector to Micro-B connector
- One plug, 3.5mm pitch, 8 position, screw-terminals wire connection, for mating with J4, the RS-232/485 and CAN connector
- Quick Start Guide for DK-S124

The following components are not included in the DK-S124, but may be useful for test, demonstration, or design evaluations:

- AC to 5 VDC power adapter, 6 W or greater output, center positive, barrel plug 2.1 mmID 5.5 mmOD >9 mm insertion, for testing or use of the DK-S124 main board without USB connected
- CR2032 lithium battery for battery life testing and current measurements
- Bluetooth capable modules, PC, tablet, smart phone, or other device for testing and demonstrating the Bluetooth standard or low-energy interface
- 3-mm (1/8") stereo headphone jack ear buds for demonstrating audio output
- Second USB Type-A to Micro-B cable for debugging while the S124 is talking to an external USB host
- Seeed Grove I2C interface modules to demonstrate operation of this interface
- SPI and/or I2C external communications interface devices for demonstrating operation of these interfaces

1.3 Environmental Characteristics

The DKS124 is not designed as a production unit to be used direction in OEM equipment. Contact Renesas for a list of hardware design partners who can develop and deliver -productionready- platforms based on the ingredients used in the DK-S124 kit.

The environmental characteristics are separated into two components: the PCB with circuitry and the Liquid Crystal Display with Touch Panel; the PCB will continue to operate in its full operational range even if the LCD is outside its operational range.

Table 1: Environmental Temperature and Humidity Limits

Specification	Permissible			
	Minimum	Typical	Maximum	Unit
Storage Temperature	-40	25	85	C
Operating Temperature	-40	25	80	C
Humidity (Non-condensing)	5%		95%	RH

1.4 Physical Characteristics

The outer dimensions of the DK-S124 are approximately 133.3 x 133.2 x 15.3 mm. Weight of the unit is approximately 86 grams.

1.5 Block diagram

Figure 2: Block Diagram: Main Board

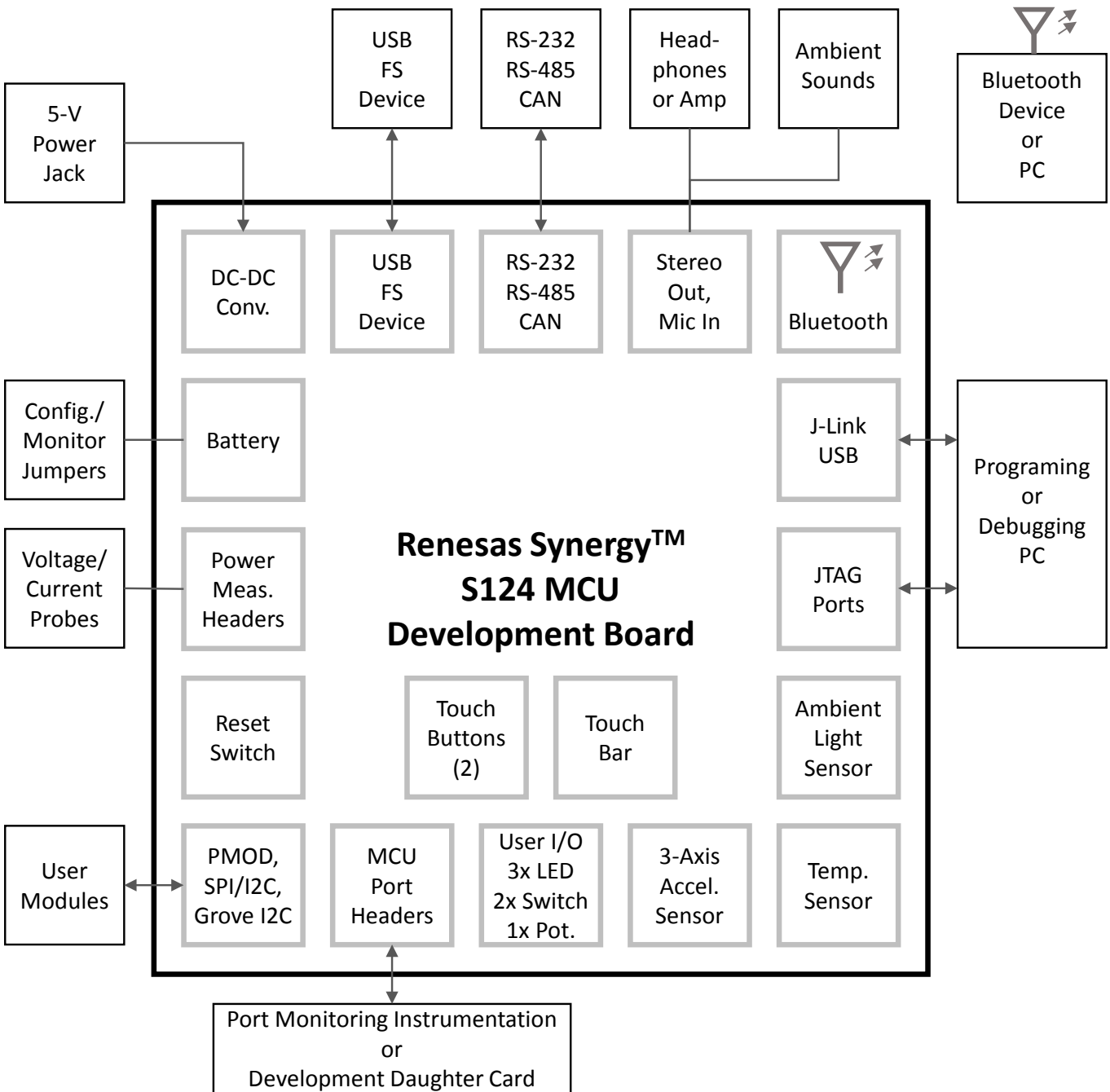

1.6 Hardware features

1.6.1 Main Board

1.6.1.1 MCU and Board Memory

- Synergy S1 MCU
 - 32-MHz ARM Cortex™-M0+ core
 - 16 kB on-chip SRAM
 - 64 or 128-KB on-chip code flash memory
 - 4-KB on-chip data flash memory
 - For additional peripherals, features, and configurations availability, see the S124 User's Manual: Microcontrollers
- 32 MBytes SPI serial flash memory
- 32.768-kHz RTCC crystal and 16MHz MCU clock crystal
- MCU reset push-button switch

1.6.1.2 Power

- Main power input of 5 V to a barrel jack or USB Device input of 5 V
- High efficiency 5-V to 3.3-V system power DC-DC converter
- Low noise 5-V to 3.3-V power regulator for MCU analog functions
- Coin cell holder for lithium CR2032 for low-power operations testing
- Several jumper-configurable headers to allow selection of regulated or battery power source, and monitoring currents and voltages

1.6.1.3 I/O Features

- CAN transceiver (1 Mbit/s)
- Configurable RS-232/RS-485 port on an industrial-style 3.5-mm screw terminal plug connector
- Stereo audio output with headphone jack and single microphone input
- Full-Speed USB 2.0 Device port (micro-B)
- PMOD 12-pin multi-type expanded interface (firmware configured)
- SEED Grove I2C interface
- 8-pin header SPI&I2C interface
- Two 22-position headers allowing access to power busses and to many MCU signal ports
- Two capacitive touch buttons and one capacitive touch-slider
- Three user configurable LEDs (red, yellow, and green)
- Two user configurable momentary button switches

- User-adjustable manual thumb-wheel potentiometer
- Ambient light sensor, circuit-board temperature sensor, board-mounted 3-axis accelerometer
- Bluetooth dual mode module (Classic and BLE)

1.6.1.4 Programming and Debug Features

- 10-pin 0.05" pitch SWD programming connector (J13) included for direct programming/debug access
- J-Link USB Micro-B connection provided with separate supporting microcontroller to allow SWD programming and debug of the S124 microcontroller using a USB interface
- Separate Tag-Connect interface pin-pattern provided for programming the J-Link microcontroller, if needed

1.6.2 RSK PMOD Display Board

- Powered by the Main Board
- Provides all support circuitry to convert serial data to displayed data

1.7 Usage Models

The DK-S124 is designed as a hardware design kit platform as well as software development platform for OEM applications requiring some Human Machine Interface (HMI) and communications capabilities. The platform has some direct machine-control-support GPIO available through the PMOD and Seeed Grove ports, although the platform may also be used in conjunction with an OEM's intelligent I/O and power subsystem, possibly communicating with that subsystem over RS-232, RS-485, CAN, Bluetooth, or UART/I2C/SPI.

1.8 Hardware Versions

There is one version of the DK-S124 currently in circulation, v2.0.

1.9 Resources

The following documents are related to S124 and DK-S124 hardware:

- [DK-S124 Quick Start Guide](#) (printed copy in DK-S124)
- [DK-S124 Schematics](#)
- [S124 User's Manual](#)
- [S124 Datasheet](#)

You can find all Renesas Synergy documents here: <http://renesassynergy.com/docs>.

For programming the DK-S124, refer to the DK-S124 User's Manual (this document) and the S124 User's Manual. You are likely to be programming using the Renesas e² studio tool. We recommend reviewing the e² studio release notes and manuals, and the example applications delivered with the DK-S124.

Chapter 2 Getting Started

The DK-S124 includes the Main Board assembled with bumper feet and an acrylic cover over the touch region, a PMOD serial LCD daughter card, a 3-foot (91-cm) USB Type A to Micro-B adapter cable, and a Quick Start Guide. To start working with the DK-S124, see the included Quick Start Guide.

Figure 3: DK-S124

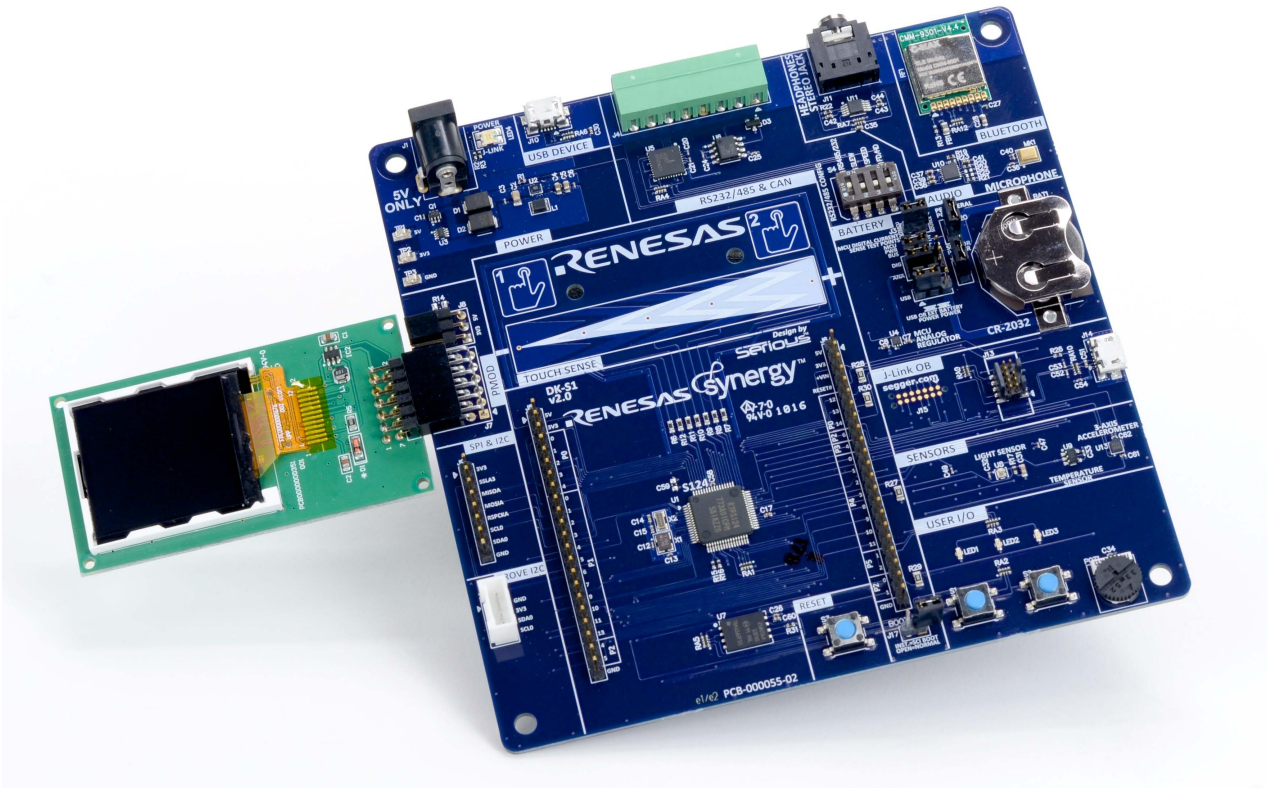

2.1 Powering the DK-S124

Prior to providing power with one of the three power options, make sure that the power jumpers in the BATTERY labeled region of the DK-S124 main board are properly installed. For non-battery operation, and without an ammeter installation, J3, J19, and J20 should all have jumpers installed across their two pins. Also, the two SOURCE SELECT header jumpers, J2 and J18, should have a total of three jumpers installed from their center terminal to their left-most terminal for each row of terminals.

The DK-S124 can be powered via three different methods:

- 5-V power source at the -5V external power connection, J1, on the DK-S124 main board. Note that the outer sleeve of the barrel connector must be negative, and the center of the connector must be positive.
- External USB host to the J-Link USB connector, J14, on the DK-S124 main board.
- CR2032 coin cell battery in the BAT1 holder on the DK-S124 main board. Note that this option may require one of the other two listed power sources also be installed for proper operation of the J-Link interface, which may affect reboot of the S124 processor. For proper operation and use of the coin cell battery, jumpers on J2 and J18 may need be changed to jump the center terminal to the right-most terminal, and J19 and J20 may or may have jumpers installed between their terminals (removal of the jumper unpowers the circuitry served by J19 or J20).

If power is supplied from the 5-V barrel connector, a green LED should be lit in LED4 making that LED green. If power is from the USB port, both LED4 LEDs are lit on J-Link MCU commands making LED4 appear orange. LED4 is located in the box labeled "POWER" on the DK-S124. LED4 is not powered by the coin cell with jumpers properly installed.

If both the barrel connector is powered, and the J-Link USB port is powered, LED4 will change to orange on J-Link MCU commands and power from the DK-S124 will be taken from the source with the higher voltage, or shared if the loaded higher-voltage source voltage droops to the open-circuit voltage of the other source.



There is limited voltage protection on the 5-V direct power input. Using a reverse-polarity barrel plug power source may permanently damage the unit.

2.2 See the Demo

A demo (pre-installed on the DK-S124) will start up when the unit is first powered. If during the course of software development this demo is erased from the flash memory you can download this demo from the renesas.com website and re-install it using the e² studio software development tools, the USB Type A to USB Micro-B cable, and the Segger J-Link On-Board debugger USB interface.

Chapter 3 Power Supplies

3.1 Power supply

Power may be supplied to the DK-S124 from three sources:

- The barrel jack J1 in the upper left corner of the circuit board, with +5 V to the center of the mating plug and 0 V to the outer sleeve of the mating plug
- The USB Micro-B J-Link jack J14 adjacent to the battery holder
- A CR2032 lithium coin cell installed in BAT1 holder near the right edge of the circuit board

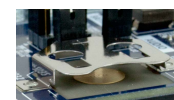
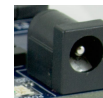

When power to the S124 MCU is supplied from the lithium coin cell, power from one of the other two sources should be available to power the J-Link and related support circuitry. This will allow proper restarting of the S124 MCU.

3.2 Power-up behavior

The DK-S124 is delivered preloaded with a demonstration program. The demonstration program shows several features of the DK-S124 and source code is available as a programming example for developers. See the Quick Start Guide delivered with the DK-S124 for details of use of and expected board behavior when running the demonstration program.

When powered from J-Link USB or the barrel jack, the green LED in LED4 adjacent to the barrel jack will be lit. The red LED in LED4 will be controlled by the J-Link microcontroller in accordance with J-Link specifications. When both LEDs are lit, LED4 will appear orange.

3.3 Battery supply configuration

See Chapter 6 for configuration details.

3.4 +5-V Main Voltage Rail

Dual low-drop Schottky diodes merge the two power inputs (barrel connector input and J-Link USB supply) so that whichever is available and higher is delivered downstream as the power rail +5V to power supplies for the circuitry on the DK-S124.

Figure 4: Power Section of Main Board



Figure 5: +5V Main Rail Schematic Extract

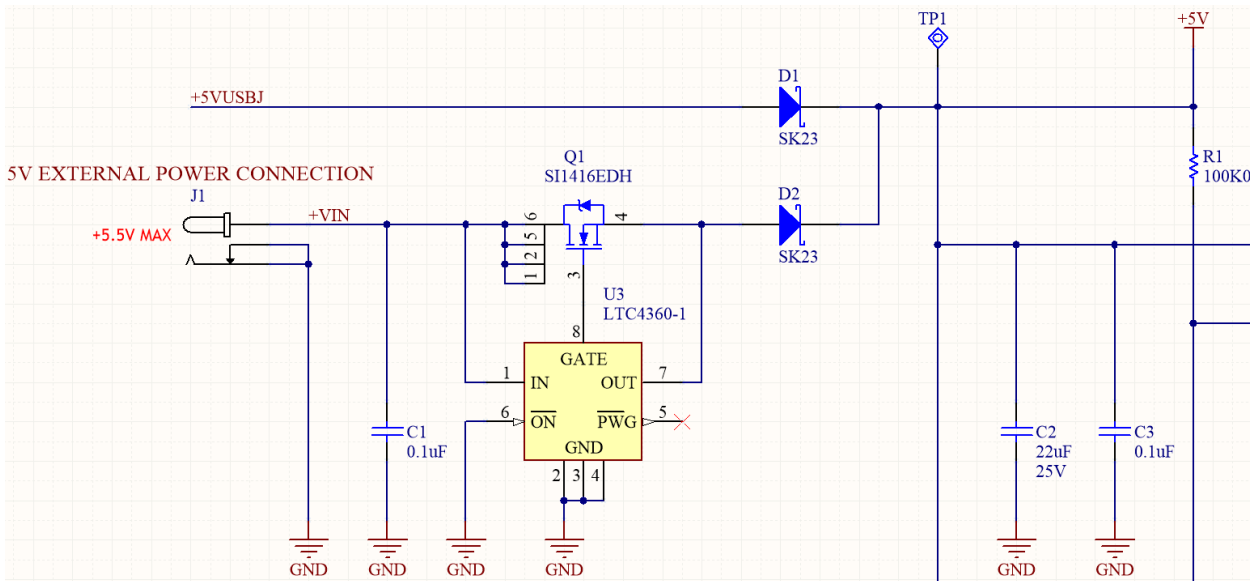

3.5 3.3-V Main Power Subsystem

Almost all the circuits on the board require 3.3 volts, including MCU, memory, and logic. The +5-V Main Voltage Rail power is delivered to the [ISL91107 buck-boost switcher](#). This switcher, using a tiny inductor, creates 3.3 V at up to 2 A to the DK-S124. It can operate with +5-V rail voltage between about 5.8 V and about 2 V. The variant of the switcher shown is internally set for FB pin voltage of 3.3 V.

Figure 6: 3.3V Regulator Schematic Extract

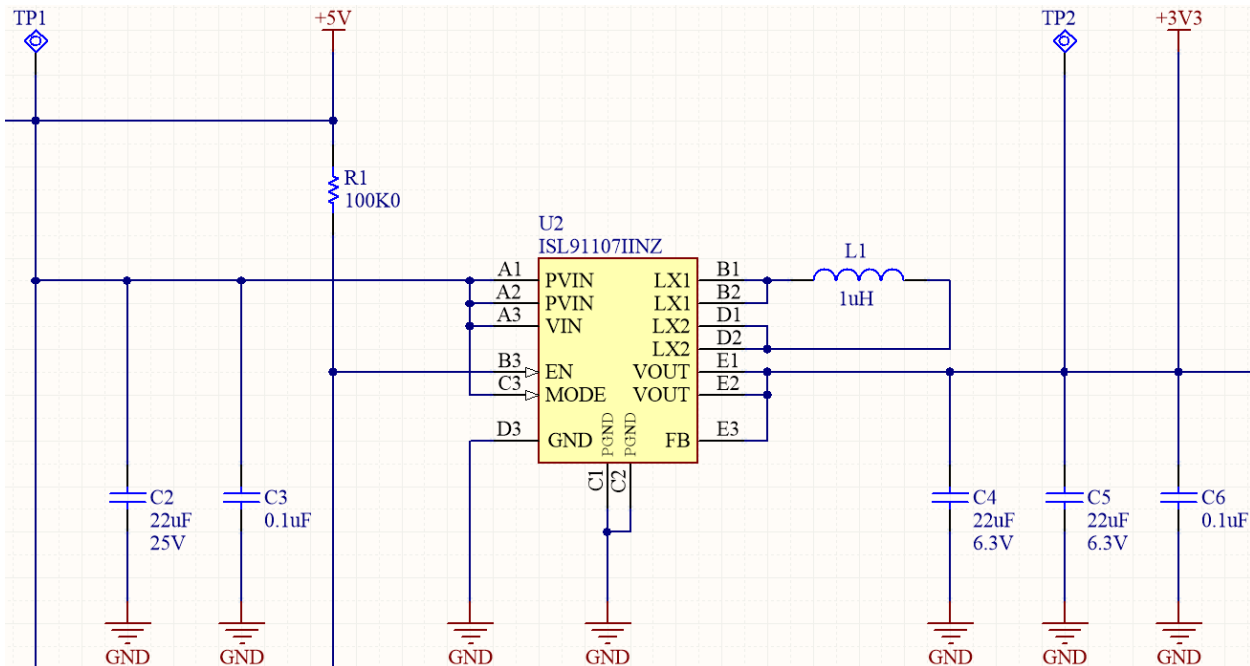

3.6 Power LED

LED4 on the DK-S124 indicates the currently used source of power on the system. LED4 has two LEDs in one package (red, green) so three colors can be visible: red, green, and orange (when both are lit).

When the green portion of LED4 is lit, the 3.3-V Main Power Subsystem is currently under power. The J-Link MCU controls when the red portion of LED4 is lit.

Therefore, LED4 orange indicates both J-Link MCU activity and 3.3-V Main Power available, and LED4 green indicates 3.3-V Main Power available, implying the availability of either 5 V from barrel jack J1 or 5 V from the J-Link USB connector J14.

3.7 Power Budgets

Table 3 summarizes the power budgets associated with each subsystem, including the typical efficiency losses through each corresponding power conversion subsystem. These values are very conservative.

Table 2: Subsystem Power Estimates

Subsystem	Power Requirements (mW)		Power Supply	Typical Efficiency ²	5-V Input Power (mW)	
	Typ	Max			Typ	Max
MCU VCC ¹	12	40	+3V3MCU	90%	13	43
MCU AVCC ³	0.6	13	+3V3ANA_MCU	66%	0.9	20
MCU VCC_USB + VCC_USB_LDO ⁴	0.9	15	+3V3MCU	90%	1	17
LED4	10	14	+3V3	90%	11	15
User LEDs (all lit)	79	99	+3V3MCU	90%	88	110
CAN ⁵	29	530	+5V	100%	29	270
RS-232/485 ⁶	19	1250	+5V	100%	19	1250
Serial flash memory ⁷	0.9	66	+3V3	90%	1	73
Bluetooth ⁸	0.003	42	VPER	90%	0.01	47
Microphone Input	10	20	+3V3	90%	11	22
Stereo Output	14	63	+3V3	90%	16	70
J-Link MCU Circuit	TBD	230	+3V3	90%	150	360
Thumbwheel Pot.	1	1	+3V3	90%	1.1	1.1
Light Sensor	0.3	1.3	VSNS	90%	0.3	1.4
Temperature Sensor	0.0	0.2	VSNS	90%	0.0	0.2
3-Axis Accelerometer	0.4	0.6	VSNS	90%	0.4	0.7

Notes:

1. MCU current is heavily dependent on firmware and mode of the MCU. Values shown based on datasheet tables in section 41.2.9, MCU in normal mode with clock frequency 16 MHz.
2. Efficiency for power includes the estimated regulator efficiency and an estimated diode loss based on 0.23-V forward drop (room temperature, 40-mA diode current). The diode forward drop increases with 5-V load current.
3. AVCC typical current for low power conversion, reference power supply operating, temperature sensor OFF, low-power analog comparator OFF, assuming 10% duty cycle of A/D conversions and 10% duty cycle of D/A conversions. Max current for high-speed conversion 100% duty cycle. Efficiency based on linear LDO regulator rather than switcher.

4. USB current does NOT include additional load on MCU_VCC line during USB operations. Typical values estimated for 10% communications, Max for 4x datasheet typical at 100% communications (no max on datasheet).
5. CAN typical 10% receive, 10% transmit, 80% standby. Max 100% transmit. Power taken from +5-V bus and internal chip regulation "enhanced" by Schottky selector diode drop.
6. Typ is for RS-232 mode (RS-485 about half value shown), worst case is RS-485 shorted. Only 5-V current considered, 3.3-V load is <0.3 mW.
7. Typ is 0.1% write/erase, 20% read (program load, data load), 79.9% standby. Max is 100% erase or write. SPI Clock from MCU is 8 MHz.
8. Typ is OFF, Max is 95% Rx and 5% Tx.

Take care to ensure the total power used, including any PMODs, is under the maximum 6 W capability of the 3.3-V power subsystem.

3.8 Microcontroller Current

Power supply current to the MCU may be monitored by connecting ammeter leads of a multimeter in place of one of three jumpers on the Main Board. Jumper J3 can be used to monitor main MCU power (VCC) plus USB MCU power (VCC_USB and VCC_USB_LDO). Jumper J19 can be used to monitor MCU analog power (AVCC). Jumper J18 can be used to monitor USB MCU power alone. These current levels will likely be in the microampere range depending on the MCU mode of operation, so a benchtop multimeter may be required. Alternately, for J3, a shunt resistor may be installed on the pads labeled R4 adjacent to J3 to get voltage output for repeatable measurement. Choice of the resistor value to install will depend on current level estimated for measurement, but should be chosen to ensure less than 0.2-V drop when used.

3.9 Battery Current

Battery current can be measured by replacing the appropriate jumper with the ammeter leads of a multimeter and using J2 pins 3 and 5 to measure MCU analog power, or J2 pins 4 and 6 to measure all other circuit power. With the battery powering the circuit, supplying +5 V from J-Link USB or from the barrel connector may be needed to ensure the J-Link circuitry can operate and properly support the S124 MCU during restart.

Chapter 4 Components

4.1 RSK PMOD Display Board

A serially controlled display is provided as part of the DK-S124 to demonstrate small-display control and interface.

This display plugs into the PMOD 12-position female connector on the left edge of the DK-S124 main board.



4.2 USB Cable

One three-foot USB cable is provided as part of the DSK-S124. The connector on one end is Type A for insertion into a PC or other USB Host jack. The connector on the second is Micro-B for insertion into either the J10 USB Device or the J14 J-Link jack on the DK-S124 main board. If both connections are needed simultaneously, a second cable will be needed.



4.3 Plug, 3.5-mm-Pitch, 8-Position, Screw Terminals

A plug is provided to mate with J4 near the top center of the DSK-S124 main board to adapt from discrete wires to the modular connector on the circuit board.



4.4 Peripheral Devices

- Device: Intersil ISL41387 (U5)
 - Configurable RS-232 or RS-485 half-duplex or full-duplex serial interface
 - RS-232 configurable to 650 kbps, separate receive and transmit connections
 - RS-485 configurable to 20 Mbps, or slew rate limited for low noise at 115 kbps or 460 kbps
- Device: Infineon IFX1050G (U6)
 - CAN transmission rates from 1 kbps to 1 Mbps
 - EMC susceptibility and emissions optimized
- Device: Micron N25Q256A (U7)
 - SPI interface: device supports 108-MHz SPI clock, DK-S124 supports 16-MHz clock
 - 32 MByte organized for 4 KB subsector, 64 KB sector, and full chip erase operations
 - 100,000 erase cycle rating
- Device: C-Max CMM-9301-V4.4 (RF1)
 - Bluetooth 4.0 specification, Bluetooth Low Energy
 - 1-Mbps RF transfer rate, programmable output signal level
 - SPI Host Control Interface

- Device: Maxim MAX9814 (U10) with MEMS microphone (MK1)
 - AGC and low-noise microphone, 2-V bias
 - Low-power shutdown mode (not available on DK-S124)
 - Selectable output gain for maximum total gain 40 dB, 50 dB, or 60 dB
- Device: On Semiconductor NCP2809 (U11) with stereo headphone jack (J11)
 - 135 mW/channel into 16-ohm stereo load
 - Internal gain of 0 dB, PSRR 85 dB
 - Low power shutdown mode (not available on DK-S124)
- Device: Avago ADPS-9005 (U8)
 - Spectral response near that of human eye
 - Very low power, 40 μ A at 100 Lux, 400 μ A at 1k lux
 - Analog output, +/-20% over -5C to 85C
- Device: Analog Devices TMP35 (U9)
 - Analog output, 2C accuracy, 0.5C linearity
 - <50- μ A current, shutdown mode <5 μ A (not available on DK-S124)
- Device: Bosch BMA250 (U13)
 - I2C interface, programmable ranges from +/- 2 g to +/- 16 g, programmable low pass filters
 - Motion triggered interrupt output
 - 130- μ A normal mode operating draw, 1- μ A deep suspend mode
- Device: Renesas RX621 (U12) with USB Device Port (J14)
 - Programmed to provide J-Link interface, allowing USB programming and debug of S124 MCU
 - Powered from the +3.3-V internal, +5-V derived bus, allowing separation from battery supply

4.5 CR2032 Lithium Battery

A standard size CR2032 lithium battery may be used to demonstrate and test battery powered operation.



4.6 External Power Supply

The DK-S124 is intended to be used with the USB cable providing power, but a barrel jack is also provided on the main board for an external 5V source. A wall-mounted AC-to-DC power converter may be used with the DK-S124, plugged into J1 near the upper left corner of the main board. A suitable converter may be Triad part number WSU050-1500, or a CUI Inc. SWI6-5-N-P5, both available from several distributors.

Chapter 5 Board Layout

Figure 7: Main Board Components, Top Side

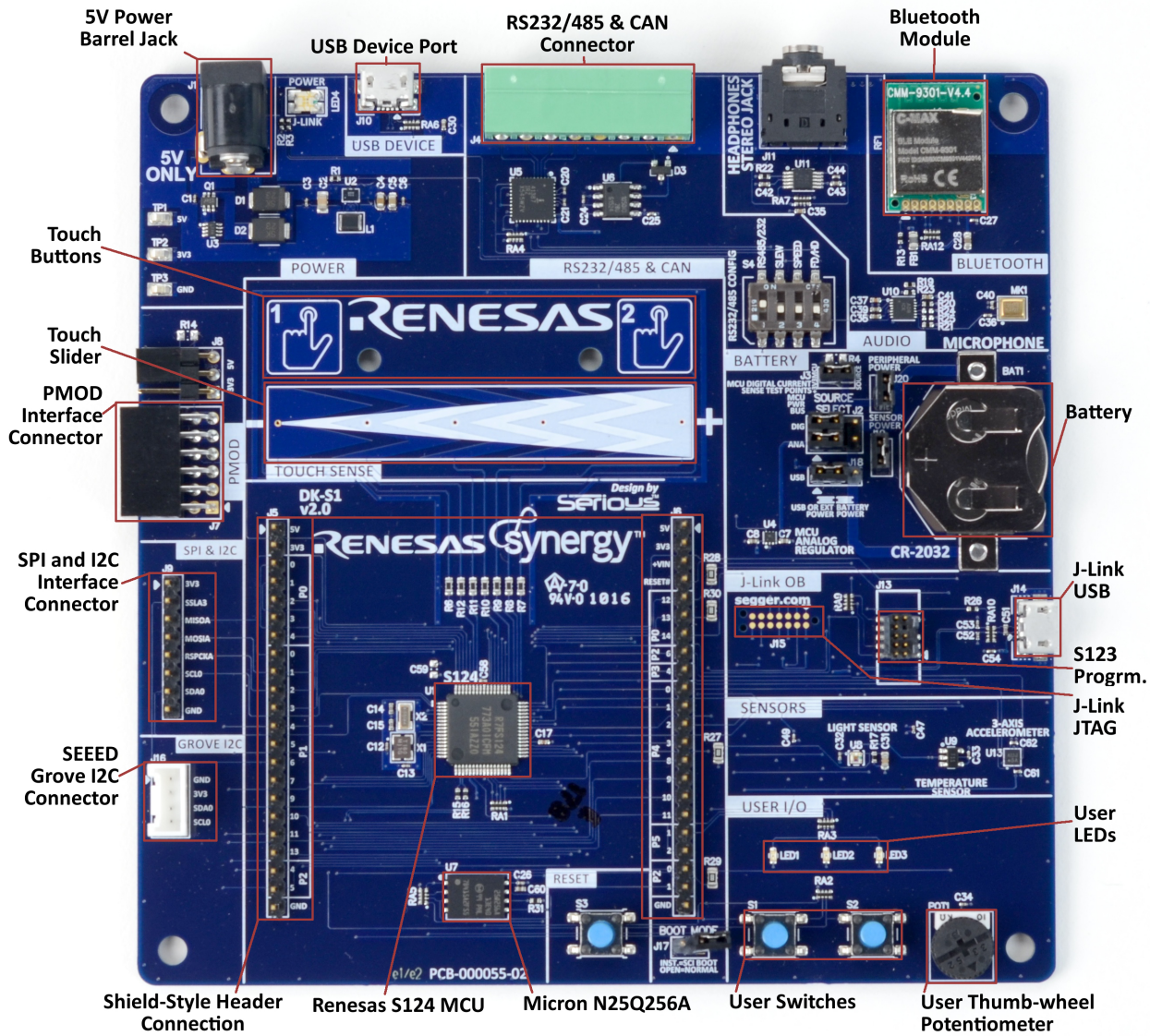
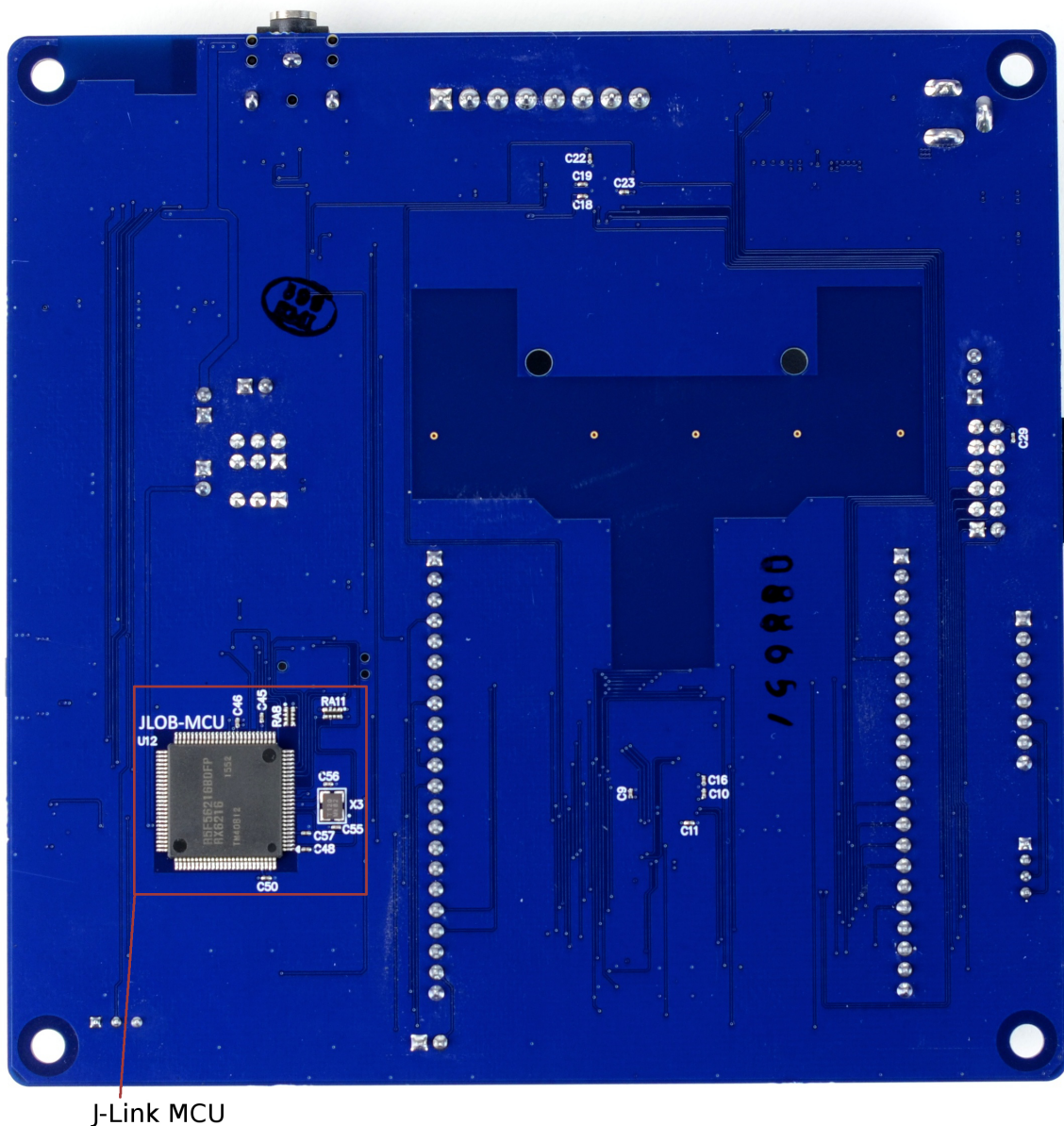

Figure 8: Main Board Components, Bottom Side



Chapter 6 Configuration

The DK-S124 has the following configuration options:

- Jumper J17 for S124 MCU boot configuration
- Jumpers J2, J3, J18, J19, J20, for battery/5 V power source selection
- DIP switch S4 for RS-232/485 transceiver configuration

6.1 MCU Boot Configuration Jumper

Jumper J7 is found near the bottom edge of the Main Board and adjacent to User Switches. Installation of a jumper across the pins of J7 prior to a MCU RESET causes the S124 MCU to forsake its on-chip flash memory single-chip mode startup routine. Instead, an on-chip flash memory programming routine is executed to allow programming of on-chip data and code flash from the USB Device port. See the S124 User's Manual: Microcontrollers for details.



6.2 Battery and 5V Power Source Selection Jumpers

For testing of battery current to circuitry, there are several jumpers that may be used to properly connect the battery and the non-J-Link circuitry. These jumpers are located adjacent to the battery holder in the box marked BATTERY on the circuit board.



Table 3: Battery and 5V Power Jumpers

Source Select	Desired Power Condition	Jumper Installed	Comment
DIG	5-V derived 3.3 V	J2-2 to J2-4 (Top Row Left-to Center)	Power to MCU VCC pins and biasing for Boot Mode, NMI, SCL0 and SDA0 pins
DIG	Battery supplied	J2-6 to J2-4 (Top Row Right-to Center)	Power to MCU VCC pins and biasing for Boot Mode, NMI, SCL0 and SDA0 pins
ANA	5-V derived 3.3 V	J2-1 to J2-3 (Bottom Row Left to Center)	Power to MCU AVCC pin
ANA	Battery supplied	J2-5 to J2-3 (Bottom Row Right to Center)	Power to MCU AVCC pin
USB	5-V derived 3.3 V	J18-1 to J18-2 (Left to Center)	Power to MCU USB and USB_LDO pins
USB	Battery supplied	J18-3 to J18-2 (Right to Center)	Power to MCU USB and USB_LDO pins

Note that a jumper might be temporarily replaced by multimeter ammeter leads to verify battery or 3.3-V regulator current to each of these buses.

J3 will normally have a jumper installed across its pins, which may be replaced by multimeter ammeter leads to check the current of the DIG line in the prior table. In addition, a resistor may be optionally installed at R4 position adjacent to J3 for a more permanent current sampling capability using a voltmeter. The resistor should

be chosen to have less than a 0.1-V drop at maximum expected load. With a resistor installed at R4, the jumper may be removed, since the connection will always be made.

J19 will normally have a jumper installed across its pins. Removing the jumper will remove power from the light sensor, the temperature sensor, and sensor portions of the 3-axis accelerometer. See the accelerometer datasheet for signals from the MCT to properly configure the accelerometer digital interface to minimize power consumption. Jumper J19 may also be replaced by multimeter ammeter leads to check the current being supplied to sensor loads.

J20 will normally have a jumper installed across its pins. Removing the jumper will remove power from the Bluetooth module, the PMOD interface 3.3-V pin of J8, and the Seeed Grove I2C connector J16. Jumper J20 may also be replaced by multimeter ammeter leads to check the current being supplied to peripheral loads.

The thumbwheel potentiometer, serial flash memory, POT1, CAN, and RS-232/RS-485 interface circuitry cannot be powered from the battery.

6.3 RS-232/485 Transceiver Configuration

RS-232/485 configuration DIP switch S4 is located just above the BATTERY label on the Main Board upper right region. Switch segments are marked RS-485/232 (DIP Switch column "232" in Table 5), SLEW (DIP Switch column "SLW" in Table 5), SPEED (DIP Switch column "SPD" in Table 5), and FD/HD (DIP Switch column "HALF" in Table 5).



Table 4: RS-232/485 Configuration

DIP Switches				MCU Control		TX/RX Status			Max Speed (Mbps)	Mode				
232	SLW	SPD	HALF	P0_2 RS_DEN	P0_3 RS_ON	P4_10 RXD0	J4-7 Y	J4-8 Z						
OFF ²	OFF	OFF	OFF	0	X	B-A ³	-	-	20	422/485				
				1							TXD0#	TXD0 ⁴		
			ON	0	X	B-A	-	-						
				1							H*	TXD0#	TXD0	
	ON	OFF/ ON	OFF	0	X	B-A	-	-	0.460/0.115					
				1							TXD0#	TXD0		
			ON	0	X	B-A	-	-						
				1							H ¹	TXD0#	TXD0	
ON	X	X	OFF	0	1	A#	-	-	0.460	232				
				1							TXD0#	TXD0		
				ON							0	A#	-	-
											1			
			OFF	0	0	A#	-	-	0.460					
				1							TXD0#	DNU ⁵		
				ON							0	A#	-	-
											1			

Notes:

1. **P4_10/RXD0** has a weak pull-up, ensuring that when the receiver is disabled the receive data will mark high.
2. Switch position OFF is the actuator bump nearest the BATTERY label, ON is nearest the HEADPHONES STEREO JACK.
3. A is at J4 pin 5, B is at J4 pin 6
4. **P4_11/TXD0** is the S124 UART output for the transceiver.
5. Do not use.

Chapter 7 Connectivity

7.1 Connectors

7.1.1 5-V Power Barrel Jack

The 5-V Power Barrel Jack connector is one means of powering the Main Board. It accepts a 5.5-mm OD x 2.1-mm ID x ≥ 9.5 -mm insertion barrel power plug. The center is positive polarity. The connector is rated 2 A.

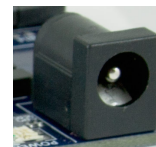

7.1.2 USB Device

The USB Micro-B connection jack connects the S124 MCU to an external USB Host, FS capable, but does not accept power from the host. Host power voltage is checked to detect connection.

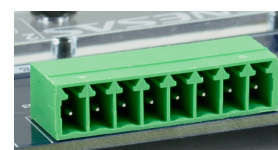

Table 5: USB Device connector (J10)

USB Device Connector		S124 Microcontroller	
Pin	Description	Logical Pin(s)	Function Name(s)
1	VBUS, +5-VDC, 15-k Ω - resistor connected in line	P4_7	P4_7/USB_VBUS
2	Data-	USB_DM	USB_DM
3	Data+	USB_DP	USB_DP
4	USB ID, jack internal switch, cable inserted	-	(Not connected)
5	Ground	VSS	(Circuit Ground)

7.1.3 RS-232/485 and CAN

The RS-232/485 and CAN connector header connects the ISL41387 RS-232/485 transceiver and the IFX1050 CAN transceiver to the mating screw-terminal-block adapter supplied with the DK-S124 kit.



The S124 MCU interfaces with the ISL41387 RS-232/485 transceiver are shown in Table 7.

Table 6: RS-232/485 Transceiver

ISL41387 RS-232/485 Transceiver		S124 Microcontroller	
Pin	Description	Logical Pin(s)	Function Name(s)
RA	Receive Channel A	P4_10	P4_10/RXD0
RB	(NOT CONNECTED)	No Connect	Not Applicable
RXEN	Receive Enable, logically compared to RXEN# (Controlled by S4 FD/HD switch)	No Connect	Not Applicable
RXEN#, DEN	Not Receive Enable, Transmit Enable	P0_2	P0_2-RS_DEN
DY	Transmitted Data Input	P4_11	P4_11/TXD0
SLEW	RS-485 slew limit setting (Controlled by S4 SLEW switch)	No Connect	Not Applicable
SPB	RS-485 speed control setting (Controlled by S4 SPEED switch)	No Connect	Not Applicable
ON	In RS-232 mode only, pin HIGH enables charge pumps for supply voltage boost	P0_3	P0_3-RS_ON
485/Not232	RS-232/485 mode selection (Controlled by S4 RS-485/232 switch)	No Connect	Not Applicable

The S124 MCU interfaces with the IFX1050 CAN transceiver is shown in Table 8.

Table 7: CAN Transceiver

IFX1050 CAN Transceiver		S124 Microcontroller	
Pin	Description	Logical Pin(s)	Function Name(s)
TXD	Data for Transmission	P1_9	P1_9/CTX0
RXD	Received Data	P1_10	P1_10/CRX0

The RS-232/485 and CAN connector header interfaces the ISL41387 RS-232/485 transceiver and the IFX1050 CAN transceiver is shown in Table 9.

Table 8: RS-232/485 and CAN connector (J4)

RS-232/485 and CAN Connector		Transceiver	
Pin	Description	Logical Pin(s)	Function Name(s)
1	CANH, CAN high	CANH	IFX1050, High line I/O
2	CANL, CAN low	CANL	IFX1050, Low line I/O
3	Not Connected	No Connect	Not Applicable
4	Ground	GND	(Circuit ground, both Xcvrs)
5	A, RS-232 channel 1 input, RS-485 inverting input	A1	ISL41387 receive A
6	B, RS-232 channel 2 input, RS-485 non-inverting input	B1	ISL41387 receive B
7	Y, RS-232 channel 1 output, RS-485 inverting output	Y1	ISL41387 transmit Y
8	Z, RS-232 channel 2 output, RS-485 non-inverting output	Z1	ISL41387 transmit Z

7.1.4 Stereo Headphone Jack

The 3.5-mm stereo output jack provides left output to the tip conductive region, right output to the middle conductive region, and output return to the cable-end conductive region of a miniature stereo phone plug. The input signal supplied to the headphone amplifier is from a *single* DAC on the S124 MCU, so only monaural sound will be possible.

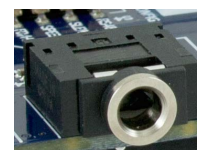

Table 9: Stereo Headphone jack (J11)

Stereo Headphone Connector		S124 Microcontroller	
Pin	Description	Logical Pin(s)	Function Name(s)
1	Common headphone return, sleeve	VSS	(Circuit Ground)
2	Left headphone signal, plug tip	P0_14	P0_14/DA0
3	Right headphone signal, plug middle ring	P0_14	P0_14/DA0

7.1.5 J-Link USB and Power

The USB Micro-B connection jack connects the J-Link MCU to an external USB Host, FS capable, and accepts power from the host, allowing re-programming and debug of the S124 MCU firmware.



Table 10: J-Link USB connector (J14)

J-Link USB Connector		J-Link OB Microcontroller	
Pin	Description	Logical Pin(s)	Function Name(s)
1	VBUS, +5VDC, connected to +5VUSBJ	-	(Not connected)
2	Data-	USB_DM	USB_DM
3	Data+	USB_DP	USB_DP
4	USB ID, jack internal switch, cable inserted	-	(Not connected)
5	Ground	VSS	(Circuit Ground)

7.1.6 S124 Programming and Debug

The 1.27-mm pitch 2x5-pin polarized header has pin 7 removed to allow use with a pin-7-plugged debug connector. The S124 Programming and Debug connector allows programming and debug of the S124 MCU using Serial Wire interface only.

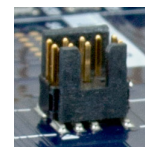

Table 11: S124 Programming and Debug connector (J13)

S124 Programming and Debug Connector		S124 Microcontroller	
Pin	Description	Logical Pin(s)	Function Name(s)
1	ARM VCC, connected to +3V3 bus	-	(config. may connect to VCC)
2	ARM SWDIO, Serial Wire Debug Data I/O	P1_8	P1_8/SWDIO
3	ARM GND	VSS	(Circuit Ground)
4	ARM SWCLK, Serial Wire Debug Clock	P3_0	P3_0/SWCLK
5	ARM GND	VSS	(Circuit Ground)
6	ARM SWO, Serial Wire Trace Output (optional)	-	(Not connected)
7	(Pin removed)	N/A	N/A
8	ARM Not Used	-	(Not connected)
9	ARM GND	VSS	(Circuit Ground)
10	ARM RESET#, Pin low resets target CPU	RES#	RESET#

7.1.7 J-Link JTAG Programming and Debug

The Tag-Connect 14-pin connection pattern, without retainer clip holes, is a JTAG programming interface to the Renesas RX621 J-Link On-Board MCU. A [Tag-Connect 14-pin adapter cable](#) will properly mate with this pattern during programming. A [friction clip](#) may be needed to hold the cable's spring-pin-connector to the board.



Table 12: J-Link JTAG Programming and Debug connector (J15)

S124 Programming and Debug Connector		J-Link OB Microcontroller	
Pin	Description	Logical Pin(s)	Function Name(s)
1	JTCK, JTAG test clock signal	P27	TCK
2	GND	VSS	(Circuit Ground)
3	JTRST, JTAG test reset signal	P34	TRST
4	JTEMLE, on-chip emulator enable	EMLE	EMLE
5	JTDO, JTAG test data out	P26	TDO
6	Unused	-	(Not connected)
7	Unused	-	(Not connected)
8	connected to +3V3 bus	VCC	MCU power
9	JTMS, JTAG test mode select	P31	TMS
10	Unused	-	(Not connected)
11	JTDI, JTAG test data in	P30	TDI
12	GND	VSS	(Circuit Ground)
13	JRES#, resistor pull-up to +3V3 bus, pin low resets J-Link OB MCU	RES#	Not Reset
14	GND	VSS	(Circuit Ground)

7.1.8 Shield-Style Header Connection

The shield-style header connection consists of two 2.54-mm-pitch 22-pin headers with their topmost and bottom-most pins aligned horizontally and parallel to each other with 57.4-mm separation. These connectors are located on either side of the S124 MCU. 5-V and 3.3-V power buses, as well as ground, are accessible on the pins of these connectors, as are many of the S124 MCU port pins. S124 MCU port pins that are load-sensitive (such as pins used for capacitive sensing), or interface high speed data and require impedance control (such as USB) are not made accessible here.

Table 13: Shield-Style Header connectors (J5 and J6)

Shield-Style Header Connectors		S124 Microcontroller	
Pin	Description	Logical Pin(s)	Function Name(s)
J5-1	connected to +5V bus	-	(Not connected)
J5-2	connected to +3V3 bus	VCC	MCU power
J5-3	light sensor analog output	P0_0	P0_0/AN000
J5-4	temperature sensor analog output	P0_1	P0_1/AN001
J5-5	ISL41387 RXEN# and DEN pins control	P0_2	P0_2-RS_DEN
J5-6	ISL41387 ON pin control	P0-3	P0-3-RS_ON
J5-7	User switch S2 monitoring	P0_4	P0_4/IRQ3

Shield-Style Header Connectors		S124 Microcontroller	
Pin	Description	Logical Pin(s)	Function Name(s)
J5-8	SPI communications for Bluetooth module, serial flash memory, SPI&I2C connector	P1_0	P1_0/MISOA
J5-9	SPI communications for Bluetooth module, serial flash memory, SPI&I2C connector	P1_1	P1_1/MOSIA
J5-10	SPI communications for Bluetooth module, serial flash memory, SPI&I2C connector	P1_2	P1_2/RSPCKA
J5-11	SPI communications chip select, serial flash memory	P1_3	P1_3/SSLA0-FLASH_CS#
J5-12	PMOD Interface, J7-7 monitoring	P1_4	P1_4/IRQ1
J5-13	SPI communications chip select, Bluetooth module	P1_5	P1_5/SSLA2-BLE_CS#
J5-14	SPI communications chip select, SPI&I2C connector	P1_6	P1_6/SSLA3
J5-15	Driven HIGH by S123 MCU to light LED3	P1_7	P1_7-LED3
J5-16	CAN transmit signal to IFX1050	P1_9	P1_9/CTX0
J5-17	CAN received signal from IFX1050	P1_10	P1_10/CRX0
J5-18	PMOD interface, J7-8 (firmware defined)	P1_11	(currently unassigned)
J5-19	Reset command to Bluetooth module	P1_13	P1_13-BLE_RST#
J5-20	PMOD configurable interface ¹	P2_4	P2_4/SCK9
J5-21	PMOD configurable interface ¹	P2_5	P2_5/CTS9
J5-22	GND	VSS	(Circuit Ground)
J6-1	Connected to +5V bus	-	(Not connected)
J6-2	Connected to +3V3 bus	VCC	MCU power
J6-3	Connected to +VIN bus	-	(Not connected)
J6-4	S124 MCU reset control	RESET#	RESET#
J6-5	User Potentiometer voltage monitor	P0_12	P0_12/AN007
J6-6	MAX9814 Microphone output signal monitor	P0_13	P0_13/AN008
J6-7	NCP 2809 input (both channels), stereo headphone jack signal	P0_14	P0_14/DA0
J6-8	S1 pulls this LOW, the BMA250 uses this as an I2C service request line	P2_6	P2_6/IRQ0/ACCEL/S1/J6-8
J6-9	PMOD interface, J7-9 (firmware defined)	P3_4	(currently unassigned)
J6-10	I2C on SPI&I2C connector, Seeed Grove connector, BMA250 accelerometer	P4_0	P4_0/SCL0
J6-11	I2C on SPI&I2C connector, Seeed Grove connector, BMA250 accelerometer	P4_1	P4_1/SDA0
J6-12	Service request from Bluetooth module	P4_2	P4_2/IRQ4-BLE_IRQ#

Shield-Style Header Connectors		S124 Microcontroller	
Pin	Description	Logical Pin(s)	Function Name(s)
J6-13	PMOD interface, J7-10 (firmware defined)	P4_3	(currently unassigned)
J6-14	PMOD configurable interface ¹	P4_8	P4_8/RXD9
J6-15	PMOD configurable interface ¹	P4_9	P4_9/TXD9
J6-16	RS-232/485 received signal from ISL41387	P4_10	P4_10/RXD0
J6-17	RS-232/485 transmit signal to ISL41387	P4_11	P4_11/TXD0
J6-18	Driven HIGH by S123 MCU to light LED1	P5_1	P5_1-LED1
J6-19	Driven HIGH by S123 MCU to light LED2	P5_2	P5_2-LED2
J6-20	Unassigned non-maskable interrupt for S124	P2_0	P2_0/NMI
J6-21	Boot mode configuration, see section 6.1	P2_1	P2_1/MD
J6-22	GND	VSS	(Circuit Ground)

Notes:

Function naming convention is port-name followed by '/' for an MCU built-in configurable feature, or by '-' for an MCU firmware-defined feature, followed by the abbreviation for the feature for that pin. Some pins use an MCU built-in configurable feature that additionally is specially and additionally modified by firmware to a specific purpose. These will include both types of feature naming in sequence, "P1_3SSLA0-FLASH_CS#", for example.

1. The four ports, P2_5, P4_9, P4_8, and P2_4 are arranged on the PMOD connector and have configurability to allow configuring the J7 PMOD interface as a Type 1 GPIO interface, a Type 2A expanded SPI interface, or a Type 4A expanded UART interface. See section 7.1.11 for details.

7.1.9 Seed Grove I2C Interface

The 4-pin Seed Grove specialty connector is provided for ready connection to Seed Grove I2C I/O modules for demonstration of various interface capabilities. Note that although P4_0 and P4_1 can be re-configured for non-I2C use, doing so will also affect the accelerometer and the SPI&I2C connector interfaces.

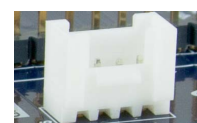

Table 14: Seed Grove I2C connector (J16)

Seed Grove I2C Connector		S124 Microcontroller	
Pin	Description	Logical Pin(s)	Function Name(s)
1	Circuit ground	VSS	(Circuit Ground)
2	VPER +3.3V bus	-	(config. may connect to VCC)
3	I2C serial clock	P4_0	P4_0/SCL0
4	I2C serial data	P4_1	P4_1/SDA0

7.1.10 SPI&I2C Interface

The SPI&I2C interface connector is an 8-pin 2.54-mm-pitch single-column header with pin connections labelled on the PCB overlay.

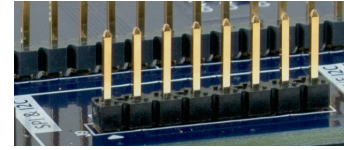

Table 15: SPI&I2C connector (J9)

SPI&I2C Connector		S124 Microcontroller	
Pin	Description	Logical Pin(s)	Function Name(s)
1	+3V3 power bus	-	(Config. may connect to VCC)
2	SPI communications chip select	P1_6	P1_6/SSLA3
3	SPI Master-In Slave-Out	P1_0	P1_0/MISOA
4	SPI Master-Out Slave-In	P1_1	P1_1/MOSIA
5	SPI serial clock	P1_2	P1_2/RSPCKA
6	I2C serial clock	P4_0	P4_0/SCL0
7	I2C serial data	P4_1	P4_1/SDA0
8	Circuit ground	VSS	(Circuit Ground)

7.1.11 PMOD Interface

The PMOD interface connector is a two-column six-row (12-pin) 2.54-mm-pitch connector with selectable power between +5 V and VPER (+3.3 V with jumper disconnect). The interface is configurable to several alternate [PMOD Standard](#) interface configurations



A PMOD Type 1 General Purpose Input Output (GPIO) interface is achieved by connecting the daughter-card to the 6 pins closest to the PCB, daughter card pin 1 on the same end as J7 pin 1 (square pad on J7 soldered pins) will properly insert daughter pin 1 to J7-6.

Table 16: PMOD connector (J7), Type 1

PMOD Connector, Type 2A (GPIO)		S124 Microcontroller	
Pin	Description	Logical Pin(s)	Function Name(s)
1	(Not connected)		
2	(Not connected)		
3	(Not connected)		
4	(Not connected)		
5	(Not connected)		
6	(Not connected)		
7	PMOD input/output 1 (IO1)	P1_4	(Discrete firmware controlled input/output)
8	PMOD input/output 2 (IO2)	P1_11	(Discrete firmware controlled input/output)
9	PMOD input/output 3 (IO3)	P3_4	(discrete firmware controlled input/output)
10	PMOD input/output 4 (IO4)	P4_3	(discrete firmware controlled input/output)
11	GND	VSS	(Circuit Ground)
12	PMOD VCC, PMODA_PWR, configurable for +5V or VPER (+3.3V)	-	(depends on configuration)

A PMOD Type 2A expanded Serial Peripheral Interface (SPI) is achieved by plugging the daughter card pin 1 into J7 pin 1. Firmware must properly configure all applicable pins.

Table 17: PMOD connector (J7), Type 2A

PMOD Connector, Type 2A (expanded SPI)		S124 Microcontroller	
Pin	Description	Logical Pin(s)	Function Name(s)
1	PMOD slave select (SS) signal	P2_5	P2_5/CTS9 (to /SS9A)
2	PMOD master out slave in (MOSI) signal	P4_9	P4_9/TXD9 (to /MOSI9)
3	PMOD master in slave out(MISO) signal	P4_8	P4_8/RXD9 (to /MISO9)
4	PMOD serial clock (SCK) signal	P2_4	P2_4/SCK9
5	GND	VSS	(Circuit Ground)
6	PMOD VCC, PMODA_PWR, configurable for +5V or VPER (+3.3V)	-	(Depends on configuration)
7	PMOD interrupt (INT) signal	P1_4	P1_4/IRQ1
8	PMOD RESET command	P1_11	(Discrete firmware controlled output)
9	PMOD unspecified signal	P3_4	(Discrete firmware controlled)
10	PMOD unspecified signal	P4_3	(Discrete firmware controlled)
11	GND	VSS	(Circuit Ground)
12	PMOD VCC, PMODA_PWR, configurable for +5V or VPER (+3.3V)	-	(Depends on configuration)

A PMOD Type 4A expanded Universal Asynchronous Receiver Transmitter (UART) is achieved by plugging the daughter card pin 1 into J7 pin 1. Firmware must properly configure all applicable pins.



Always check the jumper position prior to inserting a PMOD. Applying 5 V to a 3.3-V PMOD may damage the PMOD and potentially the DK-S124. The power to this port is not fuse protected.



The PMOD MCU pins are not 5-V tolerant. Even though some PMODs require 5 V to be powered (using the 5 position of the jumper), **do not connect 5 V or higher signals** to the MCU connected signals on this port directly. If, for example, a -fulllevel- RS-232 port is desired, use the [Digilent PMOD RS-232X](#) which plugs into the connector and translates these voltages.

Table 18: PMOD connector (J7), Type 4A

PMOD Connector, Type 4A (expanded UART)		S124 Microcontroller	
Pin	Description	Logical Pin(s)	Function Name(s)
1	PMOD clear to send (CTS) signal	P2_5	P2_5/CTS9
2	PMOD transmit data (TXD) signal	P4_9	P4_9/TXD9
3	PMOD received data (RXD) signal	P4_8	P4_8/RXD9
4	PMOD request to send (RTS) signal	P2_4	P2_4/SCK9 (to discrete firmware controlled output, RTS)

PMOD Connector, Type 4A (expanded UART)		S124 Microcontroller	
Pin	Description	Logical Pin(s)	Function Name(s)
5	GND	VSS	(Circuit Ground)
6	PMOD VCC, PMODA_PWR, configurable for +5V or VPER (+3.3V)	-	(Depends on configuration)
7	PMOD interrupt (INT) signal	P1_4	P1_4/IRQ1
8	PMOD RESET command	P1_11	(Discrete firmware controlled output)
9	PMOD unspecified signal	P3_4	(Discrete firmware controlled)
10	PMOD unspecified signal	P4_3	(Discrete firmware controlled)
11	GND	VSS	(Circuit Ground)
12	PMOD VCC, PMODA_PWR, configurable for +5V or VPER (+3.3V)	-	(Depends on configuration)

7.2 Human-Machine Interface

7.2.1 User Touch Buttons

Two capacitive touch buttons located in the upper left region of the Main Board are provided for user programmable control.



Table 19: User Touch Buttons

User Touch Button		S124 Microcontroller	
Designator	Description	Logical Pin(s)	Function Name(s)
TS1	User capacitive touch button 1 (leftmost)	P0_10	P0_10/TS30
TS2	User capacitive touch button 2 (rightmost)	P3_1	P3_1/TS9

7.2.2 User Touch Slider

One capacitive 5-segment touch slider, TSL1, is provided for user programmable control.

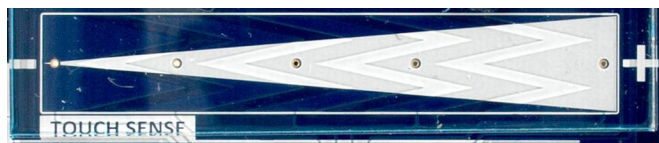

Table 20: User Touch Slider

User Touch Slider		S124 Microcontroller	
Designator	Description	Logical Pin(s)	Function Name(s)
TSL1-1	User capacitive slider segment 5 (leftmost)	P3-2	P3-2/TS8
TSL1-2	User capacitive slider segment 4 (left-center)	P3_3	P3_3/TS2

User Touch Slider		S124 Microcontroller	
Designator	Description	Logical Pin(s)	Function Name(s)
TSL1-3	User capacitive slider segment 3 (center)	P5_0	P5_0/TS27
TSL1-4	User capacitive slider segment 2 (right-center)	P0_15	P0_15/TS28
TSL1-5	User capacitive slider segment 1 (rightmost)	P0_11	P0_11/TS31
-	Capacitive Sensor Ground Reference	P1_12	P1_12/TSCAP

7.2.3 User Push-Button Switches

Near the bottom right corner of the Main Board in the User Input/Output region are two momentary push-button switches, S1 and S2, provided for programmable control.

Figure 9: User Input/Output Region of Main Board

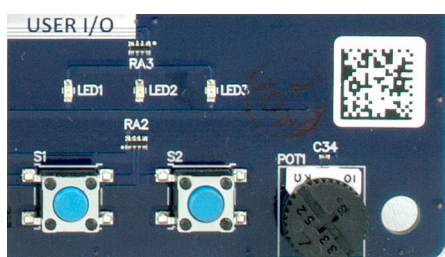

Table 21: User Push-Button Switches

User Touch Button		S124 Microcontroller	
Designator	Description	Logical Pin(s)	Function Name(s)
S1	Push Button Switch 1 (leftmost), LOW when pressed	P2_6	P2_6/IRQ0/ACCEL/S1/J6-8
S2	Push Button Switch 2 (rightmost), LOW when pressed	P0_4	P0_4/IRQ3

Note that the interface for S1 also includes the interrupt interface for the accelerometer.

7.2.4 User LEDs (3)

Immediately above the user push button switches are one red, one yellow, and one green LED provided for user programmable control

Table 22: User Push-Button Switches

User LED		S124 Microcontroller	
Designator	Description	Logical Pin(s)	Function Name(s)
LED1	LED 1 (leftmost, red), power from MCU	P5_1	P5_1-LED1
LED2	LED 2 (center, yellow), power from MCU	P5_2	P5_2-LED2
LED3	LED 3 (rightmost, green), power from MCU	P1_7	P1_7-LED3

7.2.5 User Potentiometer

Immediately to the right of the user push button switches is one 10-kΩ thumbwheel potentiometer with its voltage tap fed to MCU's ADC.

Table 23: User Potentiometer

User Potentiometer		S124 Microcontroller	
Designator	Description	Logical Pin(s)	Function Name(s)
POT1	10-kΩ thumbwheel potentiometer	P0_12	P0_12/AN007

7.2.6 Reset Push-Button Switch

A momentary switch located near the center of the lower edge of the Main Board, S3, will cause an S124 MCU reset when pressed.

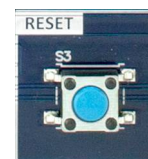

Table 24: Reset Switch

Reset Switch		S124 Microcontroller	
Designator	Description	Logical Pin(s)	Function Name(s)
S3	Push Button Switch, LOW when pressed	RESET#	RESET#

7.3 Main Board Devices

7.3.1 Serial Flash Memory

The [Micron N25Q256A](#) serial flash memory communicates with the SPI A interface of the S124 MCU.

Table 25: Serial Flash Interface (U7)

Serial Flash		S124 Microcontroller	
Pin	Description	Logical Pin(s)	Function Name(s)
S#	Not Chip Select, weak pull-up to VCC	P1_3	P1_3/SSLA0-FLASH_CS#
C	SPI Clock, weak pull-down to VSS	P1_2	P1_2/RSPCKA
DQ0	S124 Output, weak pull-up to VCC	P1_1	P1_1/MOSIA
DQ1	N25Q256A Output, weak pull-up to VCC	P1_0	P1_0/MISOA
DQ2	Not Write, weak pull-up to VCC	-	(Not connected)
DQ3	Not Hold, weak pull-up to VCC	-	(Not connected)
VCC	+3V3 bus	(VCC)	(U7 not powered by battery)
VSS/PAD	Ground return	VSS	(circuit ground)

7.3.2 C-Max CMM-9301-V4.4

The Bluetooth-Low-Energy and Bluetooth Standard capable C-Max CMM-9301-V4.4 module includes an on-module antenna, and communicates with the SPI A interface of the S124 MCU.

Table 26: Bluetooth LE (RF1)

C-Max CMM-9301-V4.4		S124 Microcontroller	
Pin	Description	Logical Pin(s)	Function Name(s)
CS#	Not Chip Select, weak pull-up to VCC	P1_3	P1_5/SSLA2-BLE_CS#
SCK	SPI Clock, weak pull-down to VSS	P1_2	P1_2/RSPCKA
SDI	S124 Output, weak pull-up to VCC	P1_1	P1_1/MOSIA
SDO	CMM-9301 Output, weak pull-up to VCC	P1_0	P1_0/MISOA
RST	RESET input, weak pull-down to VSS	P1_13	P1_13-BLE_RST#
IRQ	Service request, weak pull-up to VCC	P4_2	P4_2/IRQ4-BLE_IRQ#
SEL	Interface Selection (0=UART, 1=SPI), left open	-	(Not connected)
VCC	VPER (+3.3V) bus	(VCC)	(depends on configuration)
GND	Ground return	VSS	(circuit ground)

7.3.3 Maxim MAX9814 with MEMS microphone

The [Maxim MAX9814](#) microphone preamplifier (U10) with a supplied MEMS microphone (MK1) on the Main Board provides an amplified audio signal relative to omnidirectional sound levels near the circuit board. All gain, shutdown, AGC, and other settings are hard-wired on the Main Board. Unpopulated resistor pads for R24 and R25 are supplied to allow modification of the AGC and gain settings. The audio signal output by the MAX9814 is provided to the S124 at P0_13/AN008 ADC input.

7.3.4 Avago ADPS-9005

The [Avago ADPS-9005](#) (U8) provides a current output proportional to ambient light at the sensor, sampled through a 1 kΩ resistor, then provided to the S124 MCU at P0_0/AN000 ADC input. Normal light ranges will provide the MCU ADC 40 mV at 100 lux (dim office lighting), 0.4 V at 1 kilolux (sunlight, overcast), and will saturate around 2.3 V at or above 6 kilolux (sunlight in a shaded area).

7.3.5 Analog Devices TMP35

The [Analog Devices TMP35](#) (U9) provides a voltage output proportional to circuit board temperature at the sensor, provided to the S124 MCU at P0_1/AN001 ADC input. The voltage to the MCU ADC will be

$$V_{adc} = T \times 0.01 \text{ V}$$

where T is temperature in degrees Celsius in the range 10C to 125C and V_{adc} is the voltage delivered to the MCU ADC.

7.3.6 Bosch BMA250E

The [Bosch BMA250E](#) (U13) is a SPI or I2C (used on DK-S124) interface 3-axis accelerometer with ranges from +/- 2g to +/-16g selectable, low pass filtering selectable, a sample FIFO, extremely low power operating, and several modes to further reduce power. This chip provides two separate power buses, VDD for analog and internal sampling processes, and VDDIO for serial interface support. To avoid damage, the VDDIO power is

supplied from the +3V3MCU bus, and the VDD power is supplied from the VSNS bus. This device has an I2C address of 0011000b (address byte 0x30 to OR with write bit).

Table 27: 3-Axis Accelerometer (U13)

BMA250E		S124 Microcontroller	
Pin	Description	Logical Pin(s)	Function Name(s)
INT1	Service request, weak pull-up to VCC	P2_6	P2_6/IRQ0/ACCEL/S1/J6-8
INT2	(Not used, no connection)	-	(Not connected)
CSB	(Not used, no connection)	-	(Not connected)
SDO	Address select, connected to ground	-	(Not connected)
SDx	I2C serial data, weak pull-up to VCC	P4_1	P4_1/SDA0
SCx	I2C serial clock, weak pull-up to VCC	P4_0	P4_0/SCL0
PS	Protocol select, connected to VDDIO for I2C	-	(Not connected)
VDDIO	+3V3MCU bus	VCC	S124 MCU main power bus
VDD	VPER (+3.3V) bus	(VCC)	(Depends on configuration)
GND	Ground return	VSS	(Circuit ground)

Chapter 8 Glossary

8.1 Abbreviations and Acronyms

A	ampere	I2C	Inter-Integrated Circuit Serial Comms Bus
AC	Alternating Current	IC	Integrated Circuit
Accel.	Acceleration	I/O	Input / Output
ADC	Analog-to-Digital Converter	IEEE	Institute of Electrical and Electronics Engineers
Amp	Amplifier	IoT	Internet of Things
API	Application Programming Interface	IRQ	Interrupt Request
ARM	Advanced RISC Machine	J-Link	SEGGER J-Link On Board
BLE	Bluetooth Low Energy	JTAG	Joint Test Action Group (debug/program port)
C	(unit) degrees Celsius	k Ω	10 ³ Ohms
CAN	Controller Area Network	KB	Kilobyte (1024 bytes = 1 KB)
CE	EU conformity marking for products	Kb	Kilobit (1024 bits = 128 bytes)
cm	centimeter	kbps	kilobit per second
Comms	Communications	kB	kilobyte (1000 bytes = 1 kB)
Conv.	Converter	kHz	10 ³ Hertz
CPU	Central Processing Unit	LDO	Low Drop Out regulator
CSA	Canadian Standards Association	LED	Light Emitting Diode
DAC	Digital-to-Analog Converter	m Ω	10 ⁻³ Ohms
dB	decibel	mA	10 ⁻³ Amperes
DC	Direct Current	Max	Maximum
DCR	DC Resistance	Mbps	Mega-bit per second
DFN	Dual Flat NoLead- package	MCU	Microcontroller Unit
EC	European Commission	Meas.	Measurement
EMC	Electromagnetic Compatibility	MEMS	microelectromechanical system
ESD	Electrostatic Discharge	MHz	10 ⁶ Hertz
EU	European Union	Mic	Microphone
FCC	U.S. Federal Communications Commission	Min	Minimum
FET	Field Effect Transistor	mm	millimeter
FIFO	First-In First-Out (memory buffer)	ms	millisecond
FS	Full Speed (USB communications)	mW	milliwatt
GND	ground bus	m Ω	milliohm
GPIO	General Purpose Input-Output	OEM	Original Equipment Manufacturer
GUI	Graphical User Interface	PC	Personal Computer
HMI	Human Machine Interface		

Glossary

PCB	Printed Circuit Board	TV	Television
PMOD™	Digilent Peripheral Module interface	Typ	Typical
Pot.	Potentiometer	UART	Universal Asynchronous Receiver-Transmitter
PSE	Japanese appliance safety marking	μA	microampere
PSRR	Power Supply Rejection Ratio	UL	Underwriters Laboratories
RH	Relative Humidity in percent	USB	Universal Serial Bus
RISC	Reduced Instruction Set Computer	V	Volt
RS-232	Serial Comms Bus, bi-polar UART	VAC	Volts AC
RS-485	Serial Comms Bus, differential UART	Vbr	Voltage breakdown
RTCC	Real Time Clock-Calendar	VDC	Volts DC
Seeed	Seeed Technology Co., Ltd., Shenzhen, China	VDD	drain voltage
SPI	Serial Peripheral Interface	Vmax	maximum voltage
SPI and I2C	Serial Peripheral Interface and Inter-Integrated Circuit	Vmin	minimum voltage
SRAM	Static Random Access Memory	VSS	source voltage
SWD	Serial Wire Debug	W	Watt
TBD	To Be Determined (pending)	WEEE	EC Waste Electrical and Electronic Equipment Directive
Temp.	Temperature	WiFi	Wireless local area network, IEEE 802.11 based
Tja	Temperature junction-to-ambient	μF	10 ⁻⁶ Farad

8.2 Port Numbering

Renesas datasheets for MCUs generally refer to ports with numbers like “P001”, “P110”, and similar. This document generally refers to these ports as “P0_1” and “P1_10” respectively to add clarity. Port 5 bit 15 would be referred to in the datasheet as “P515”, in this manual as “P5_15”. The two forms should be considered identical in meaning.

Renesas Synergy™ Development Kit DK-S124 Disclaimer

By using this DK-S124, the user accepts the following terms, which are in addition to, and control in the event of disagreement, with Renesas' General Terms and Conditions available at <http://am.renesas.com/legal/legaltc.html>:

The DK-S124 is not guaranteed to be error free, and the entire risk as to the results and performance of the DK-S124 is assumed by the User. The DK-S124 is provided by Renesas on an "as is" basis without warranty of any kind whether express or implied, including but not limited to the implied warranties of satisfactory quality, fitness for a particular purpose, title and non-infringement of intellectual property rights with regard to the DK-S124. Renesas expressly disclaims all such warranties. Renesas does not consider the DK-S124 a finished product and therefore the DK-S124 may not yet comply with some requirements applicable to finished products, including, but not limited to recycling (WEEE), CE, UL, restricted substances (ROHS), FCC, FEE, and electromagnetic compatibility regulations. Renesas or its affiliates shall in no event be liable for any loss of profit, loss of data, loss of contract, loss of business, damage to reputation or goodwill, any economic loss, any reprogramming or recall costs (whether the foregoing losses are direct or indirect) nor shall Renesas or its affiliates be liable for any other direct or indirect special, incidental or consequential damages arising out of or in relation to the use of this DK-S124, even if Renesas or its affiliates have been advised of the possibility of such damages.

Renesas has used reasonable care in preparing the information included in this document, but Renesas does not warrant that such information is error free nor does Renesas guarantee an exact match for every application or parameter to part numbers designated by other vendors listed herein. The information provided in this document is intended solely to enable the use of Renesas products. No express or implied license to any intellectual property right is granted by this document or in connection with the sale of Renesas products. Renesas reserves the right to make changes to specifications and product descriptions at any time without notice. Renesas assumes no liability for any damages incurred by you resulting from errors in or omissions from the information included herein. Renesas cannot verify, and assumes no liability for, the accuracy of information available on another company's website.

Development Kit DK-S124 v2.0 User's Manual: Hardware

Publication Date: Rev.1.00 Jun 8, 2016

Published by: Renesas Electronics Corporation



SALES OFFICES

Renesas Electronics Corporation

<http://www.renesas.com>

Refer to "<http://www.renesas.com/>" for the latest and detailed information.

Renesas Electronics America Inc.

2801 Scott Boulevard Santa Clara, CA 95050-2549, U.S.A.
Tel: +1-408-588-6000, Fax: +1-408-588-6130

Renesas Electronics Canada Limited

9251 Yonge Street, Suite 8309 Richmond Hill, Ontario Canada L4C 9T3
Tel: +1-905-237-2004

Renesas Electronics Europe Limited

Dukes Meadow, Millboard Road, Bourne End, Buckinghamshire, SL8 5FH, U.K.
Tel: +44-1628-585-100, Fax: +44-1628-585-900

Renesas Electronics Europe GmbH

Arcadiastrasse 10, 40472 Düsseldorf, Germany
Tel: +49-211-6503-0, Fax: +49-211-6503-1327

Renesas Electronics (China) Co., Ltd.

Room 1709, Quantum Plaza, No.27 ZhiChunLu Haidian District, Beijing 100191, P.R.China
Tel: +86-10-8235-1155, Fax: +86-10-8235-7679

Renesas Electronics (Shanghai) Co., Ltd.

Unit 301, Tower A, Central Towers, 555 Langao Road, Putuo District, Shanghai, P. R. China 200333
Tel: +86-21-2226-0888, Fax: +86-21-2226-0999

Renesas Electronics Hong Kong Limited

Unit 1601-1611, 16/F., Tower 2, Grand Century Place, 193 Prince Edward Road West, Mongkok, Kowloon, Hong Kong
Tel: +852-2265-6688, Fax: +852 2886-9022

Renesas Electronics Taiwan Co., Ltd.

13F, No. 363, Fu Shing North Road, Taipei 10543, Taiwan
Tel: +886-2-8175-9600, Fax: +886 2-8175-9670

Renesas Electronics Singapore Pte. Ltd.

80 Bendemeer Road, Unit #06-02 Hyflux Innovation Centre, Singapore 339949
Tel: +65-6213-0200, Fax: +65-6213-0300

Renesas Electronics Malaysia Sdn.Bhd.

Unit 1207, Block B, Menara Amcorp, Amcorp Trade Centre, No. 18, Jln Persiaran Barat, 46050 Petaling Jaya, Selangor Darul Ehsan, Malaysia
Tel: +60-3-7955-9390, Fax: +60-3-7955-9510

Renesas Electronics India Pvt. Ltd.

No.77C, 100 Feet Road, HALII Stage, Indiranagar, Bangalore, India
Tel: +91-80-67208700, Fax: +91-80-67208777

Renesas Electronics Korea Co., Ltd.

12F., 234 Teheran-ro, Gangnam-Gu, Seoul, 135-080, Korea
Tel: +82-2-558-3737, Fax: +82-2-558-5141

Development Kit DK-S124 v2.0

User's Manual: Hardware



Renesas Electronics Corporation

R12UM0006EU0100

Mouser Electronics

Authorized Distributor

Click to View Pricing, Inventory, Delivery & Lifecycle Information:

[Renesas Electronics:](#)

[YSDKS124S20](#)



Компания «ЭлектроПласт» предлагает заключение долгосрочных отношений при поставках импортных электронных компонентов на взаимовыгодных условиях!

Наши преимущества:

- Оперативные поставки широкого спектра электронных компонентов отечественного и импортного производства напрямую от производителей и с крупнейших мировых складов;
- Поставка более 17-ти миллионов наименований электронных компонентов;
- Поставка сложных, дефицитных, либо снятых с производства позиций;
- Оперативные сроки поставки под заказ (от 5 рабочих дней);
- Экспресс доставка в любую точку России;
- Техническая поддержка проекта, помощь в подборе аналогов, поставка прототипов;
- Система менеджмента качества сертифицирована по Международному стандарту ISO 9001;
- Лицензия ФСБ на осуществление работ с использованием сведений, составляющих государственную тайну;
- Поставка специализированных компонентов (Xilinx, Altera, Analog Devices, Intersil, Interpoint, Microsemi, Aeroflex, Peregrine, Syfer, Eurofarad, Texas Instrument, Miteq, Cobham, E2V, MA-COM, Hittite, Mini-Circuits, General Dynamics и др.);

Помимо этого, одним из направлений компании «ЭлектроПласт» является направление «Источники питания». Мы предлагаем Вам помощь Конструкторского отдела:

- Подбор оптимального решения, техническое обоснование при выборе компонента;
- Подбор аналогов;
- Консультации по применению компонента;
- Поставка образцов и прототипов;
- Техническая поддержка проекта;
- Защита от снятия компонента с производства.



Как с нами связаться

Телефон: 8 (812) 309 58 32 (многоканальный)

Факс: 8 (812) 320-02-42

Электронная почта: org@eplast1.ru

Адрес: 198099, г. Санкт-Петербург, ул. Калинина, дом 2, корпус 4, литера А.