

SSL - Top Load Socket



Series 9159



The 9159 series of Board-to-Board interconnect system allows two PCB's to be mated end-to-end creating strips of LED lighting. Designed specifically for the unique Solid State Lighting (SSL) market requiring coplanar (horizontal-to-horizontal) PCB mating with a 5 Amp current rating in the smallest package available. The top loading socket allows complete PCB's to be replaced in the field without having to disassemble the entire strip of boards. The connector has a two part insulator whereby the top of the connector will slide open allowing the plug connector to be pulled out either vertically or at a slight angle. Once the PCB is replaced, the cover is slid back like a Zero Insertion Force (ZIF) connector to the closed position. The PCB layout is identical to the standard horizontal socket to maintain family commonality at the PCB level.

Additional components in the 9159 product family include:

- SSL - Horizontal Plug; Standard 2-Piece solution (10-9159)
- SSL - Cabled Plug; Supports wire-to-board applications (11-9159)
- SSL - Horizontal Socket; Standard 2-Piece solution (20-9159)
- SSL - Shorting Socket; Two position (58-9159)
- SSL - Retaining Clip; Latches BTB connectors together (80-9159)

APPLICATIONS

- Coplanar PCB mating in SSL products
- LED linear lighting strips
- Application Notes; refer to 201-01-123

FEATURES AND BENEFITS

- Slide open top; allows field reparability at the light fixture level
- Mates with standard horizontal or cabled plug; no need to change any connectors
- 5 Amp current rating; exceeds general market needs
- Gold plated BeCu spring contacts; reliability for harsh environments
- Available in white; supports SSL market preferences

ELECTRICAL

- Current Rating: 5 Amps / Contact
- Voltage Rating: 125 VAC

ENVIRONMENTAL

- Operating Temperature: -40°C to +125°C

MECHANICAL

- Insulator Material: Nylon: VL94VO
- Contact Material: BeCu / Phos Bronze
- Plating: Gold / Tin over Nickel
- Durability: 10 Cycles

HOW TO ORDER

22	9159	XXX	1	01	X	16																																
Prefix	Series	Number of Ways	2 Part PCB Strip Connector	Connector Pitch	Color Options	Plating Option																																
Socket Top Loading		<table border="1"> <thead> <tr> <th>Code</th> <th>No of Ways</th> <th>Details</th> </tr> </thead> <tbody> <tr> <td>002</td> <td>2</td> <td>Page 25</td> </tr> <tr> <td>003</td> <td>3</td> <td>Page 26</td> </tr> <tr> <td>004</td> <td>4</td> <td>Page 27</td> </tr> <tr> <td>005</td> <td>5</td> <td>Page 28</td> </tr> <tr> <td>006</td> <td>6</td> <td>Page 29</td> </tr> </tbody> </table>	Code	No of Ways	Details	002	2	Page 25	003	3	Page 26	004	4	Page 27	005	5	Page 28	006	6	Page 29	01 = 3mm	<table border="1"> <thead> <tr> <th>Code</th> <th>Color</th> <th>Application</th> </tr> </thead> <tbody> <tr> <td>0</td> <td>Black</td> <td>Industrial</td> </tr> <tr> <td>1</td> <td>White</td> <td>Lighting</td> </tr> </tbody> </table>	Code	Color	Application	0	Black	Industrial	1	White	Lighting	<table border="1"> <thead> <tr> <th>Code</th> <th>Contact</th> <th>Bracket</th> </tr> </thead> <tbody> <tr> <td>16</td> <td>Gold in Contact Area Tin on Solder Tail</td> <td>Tin all over</td> </tr> </tbody> </table>	Code	Contact	Bracket	16	Gold in Contact Area Tin on Solder Tail	Tin all over
Code	No of Ways	Details																																				
002	2	Page 25																																				
003	3	Page 26																																				
004	4	Page 27																																				
005	5	Page 28																																				
006	6	Page 29																																				
Code	Color	Application																																				
0	Black	Industrial																																				
1	White	Lighting																																				
Code	Contact	Bracket																																				
16	Gold in Contact Area Tin on Solder Tail	Tin all over																																				



SSL - Top Load Socket



Series 9159

SOCKET TOP LOADING 2 WAY 2 PART PCB STRIP CONNECTOR

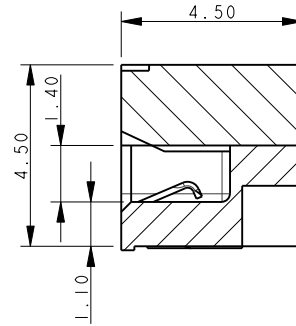
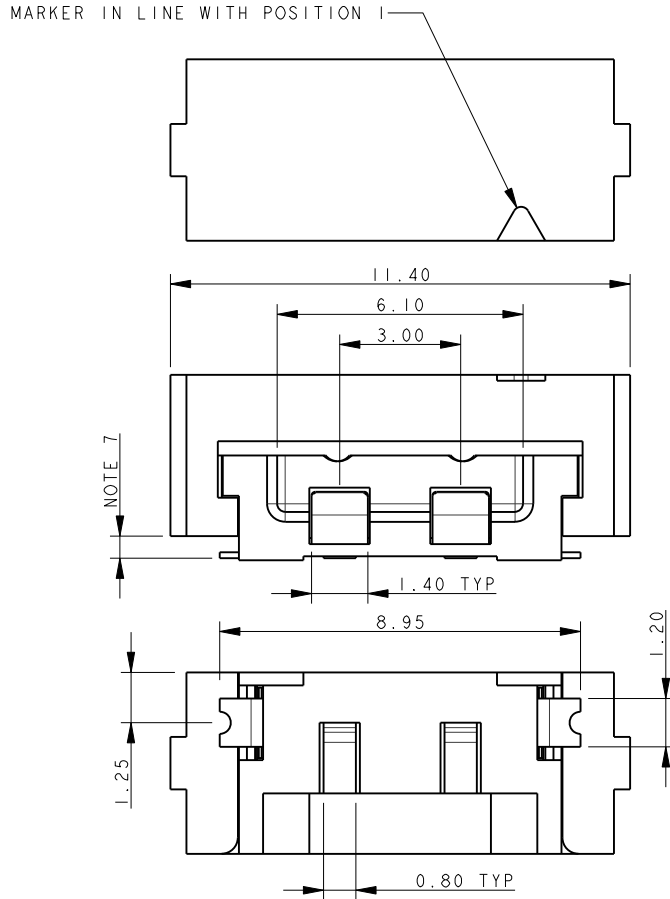

NOTES:

1. FOR MORE INFORMATION REFER TO PRODUCT SPEC 201-01-119.
2. DIMENSIONS ARE REFERENCE DIMENSIONS UNLESS TOLERANCES.
3. INSULATOR MATERIAL: NYLON 46. COLOR REFER TO PAGE 24.
4. CONTACT MATERIAL: COPPER ALLOY, GOLD OVER NICKEL.
5. BRACKETS: COPPER ALLOY, TIN PLATED.
6. OUTLINE OF CONNECTOR.
7. RESTRICTED COMPONENT HEIGHT UNDER CATCH, 2.20MM MAXIMUM.
8. RESTRICTED COMPONENT HEIGHT UNDER CATCH, 0.40MM MAXIMUM.
9. PACKING TAPE AND REEL, QUANTITY 1400 PER REEL.

2 WAY PCB BOARD LAYOUT

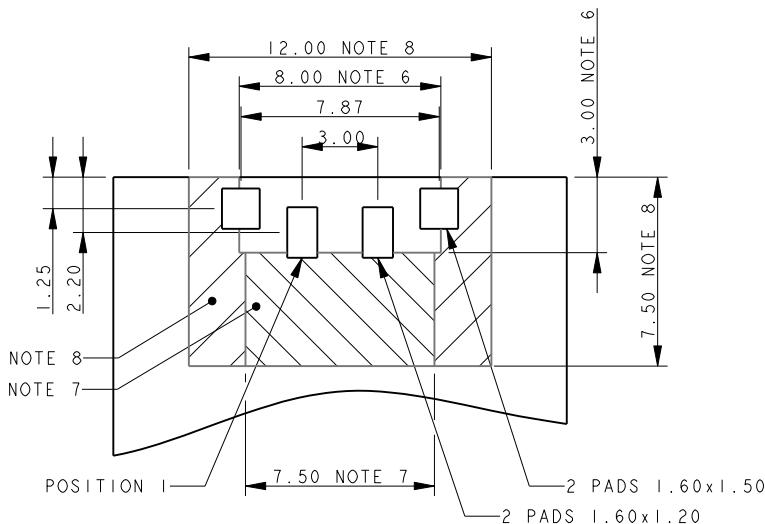

PACKING DETAILS

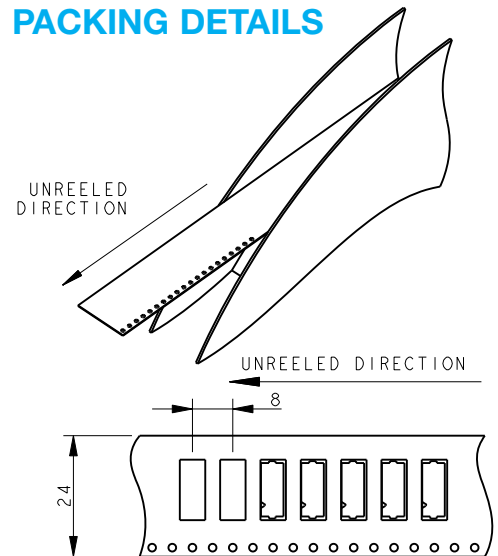

SSL - Top Load Socket

Series 9159



SOCKET TOP LOADING 3 WAY 2 PART PCB STRIP CONNECTOR

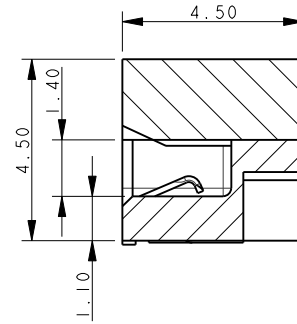
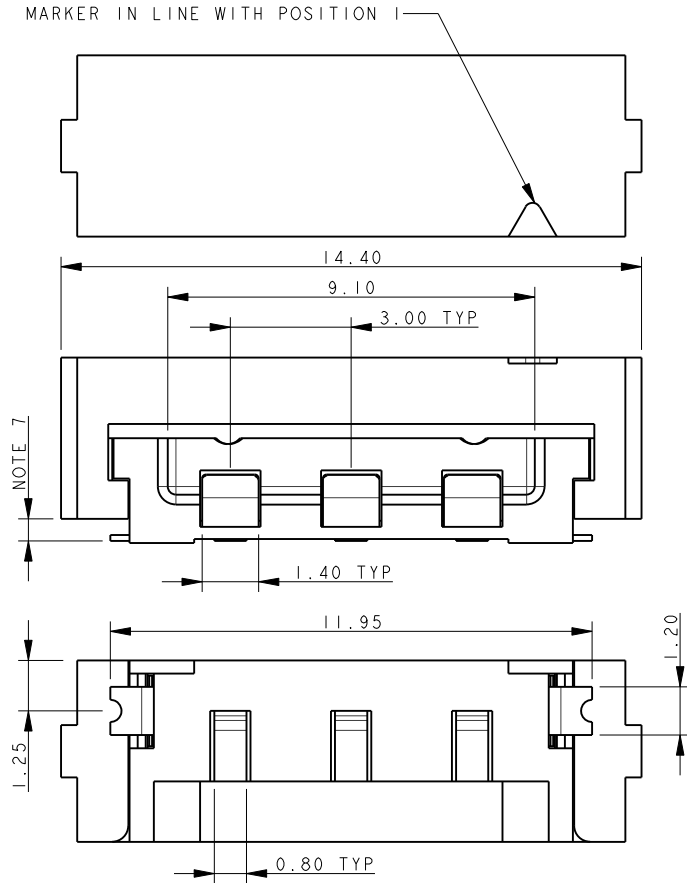

NOTES:

1. FOR MORE INFORMATION REFER TO PRODUCT SPEC 201-01-119.
2. DIMENSIONS ARE REFERENCE DIMENSIONS UNLESS TOLERANCES.
3. INSULATOR MATERIAL: NYLON 46. COLOR REFER TO PAGE 24.
4. CONTACT MATERIAL: COPPER ALLOY, GOLD OVER NICKEL.
5. BRACKETS: COPPER ALLOY, TIN PLATED.
6. OUTLINE OF CONNECTOR.
7. RESTRICTED COMPONENT HEIGHT UNDER CATCH, 2.20MM MAXIMUM.
8. RESTRICTED COMPONENT HEIGHT UNDER CATCH, 0.40MM MAXIMUM.
9. PACKING TAPE AND REEL, QUANTITY 1400 PER REEL.

3 WAY PCB BOARD LAYOUT

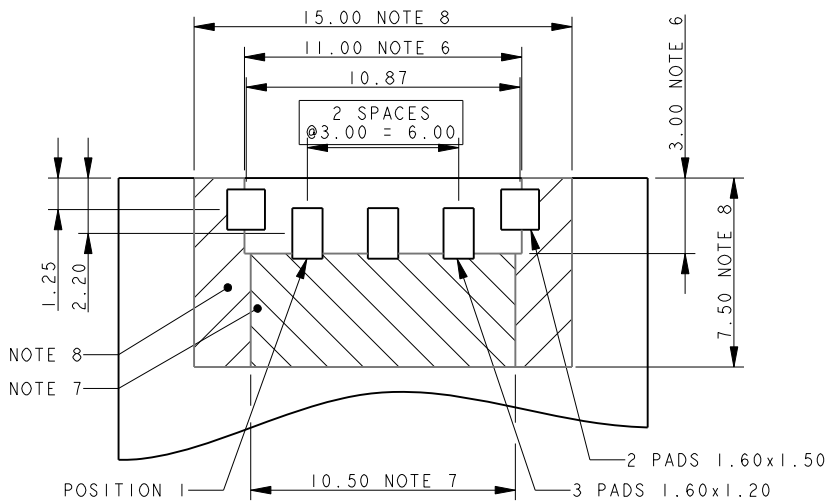

PACKING DETAILS

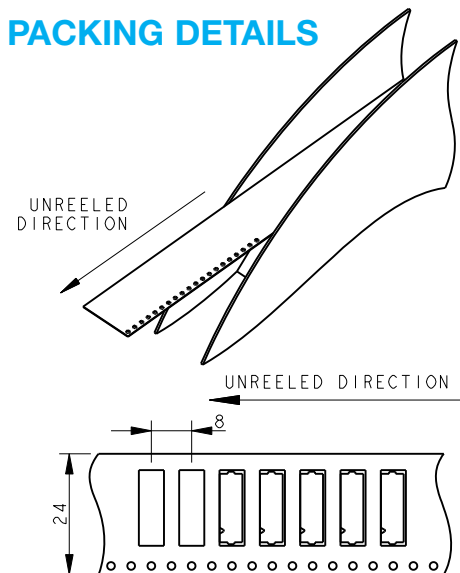

SSL - Top Load Socket



Series 9159

SOCKET TOP LOADING 4 WAY 2 PART PCB STRIP CONNECTOR

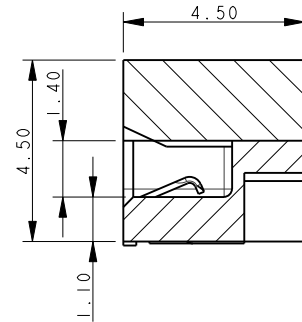
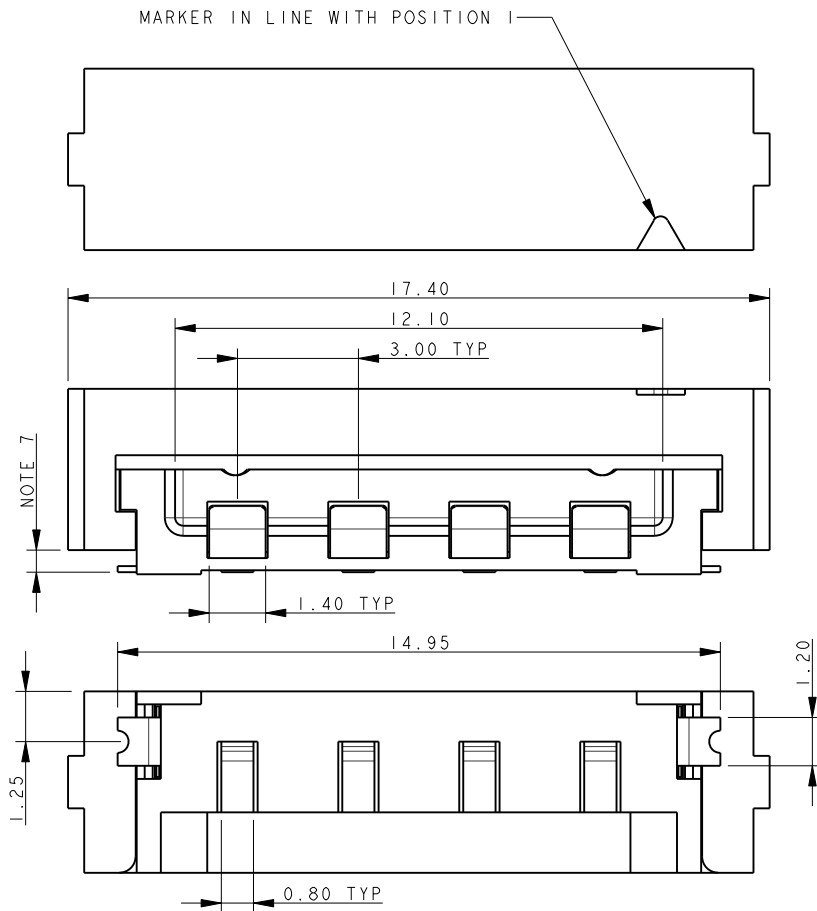

NOTES:

1. FOR MORE INFORMATION REFER TO PRODUCT SPEC 201-01-119.
2. DIMENSIONS ARE REFERENCE DIMENSIONS UNLESS TOLERANCES.
3. INSULATOR MATERIAL: NYLON 46. COLOR REFER TO PAGE 24.
4. CONTACT MATERIAL: COPPER ALLOY, GOLD OVER NICKEL.
5. BRACKETS: COPPER ALLOY, TIN PLATED.
6. OUTLINE OF CONNECTOR.
7. RESTRICTED COMPONENT HEIGHT UNDER CATCH, 2.20MM MAXIMUM.
8. RESTRICTED COMPONENT HEIGHT UNDER CATCH, 0.40MM MAXIMUM.
9. PACKING TAPE AND REEL, QUANTITY 1400 PER REEL.

4 WAY PCB BOARD LAYOUT

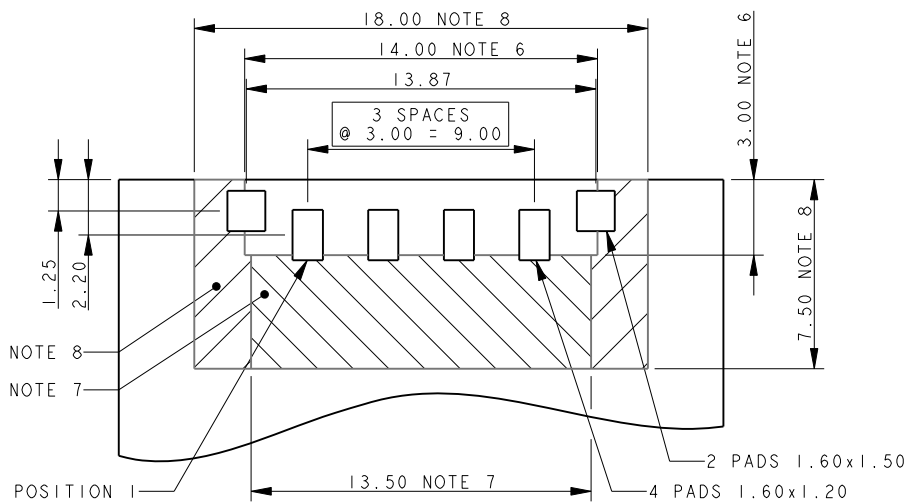

PACKING DETAILS

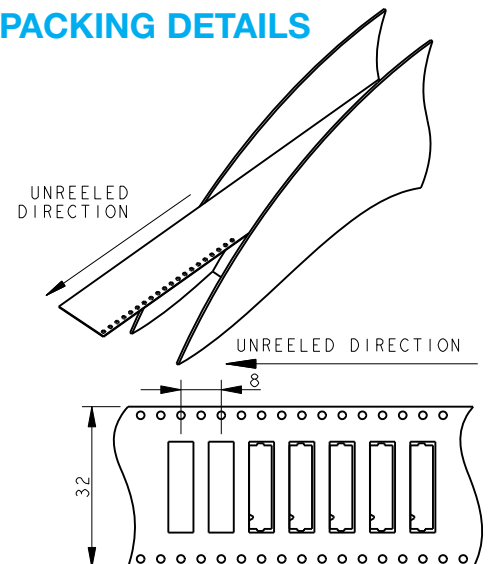

SSL - Top Load Socket

Series 9159



SOCKET TOP LOADING 5 WAY 2 PART PCB STRIP CONNECTOR

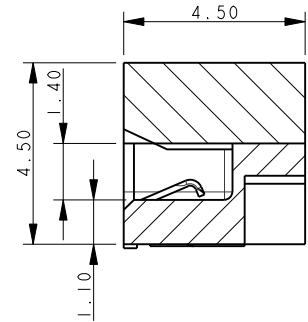
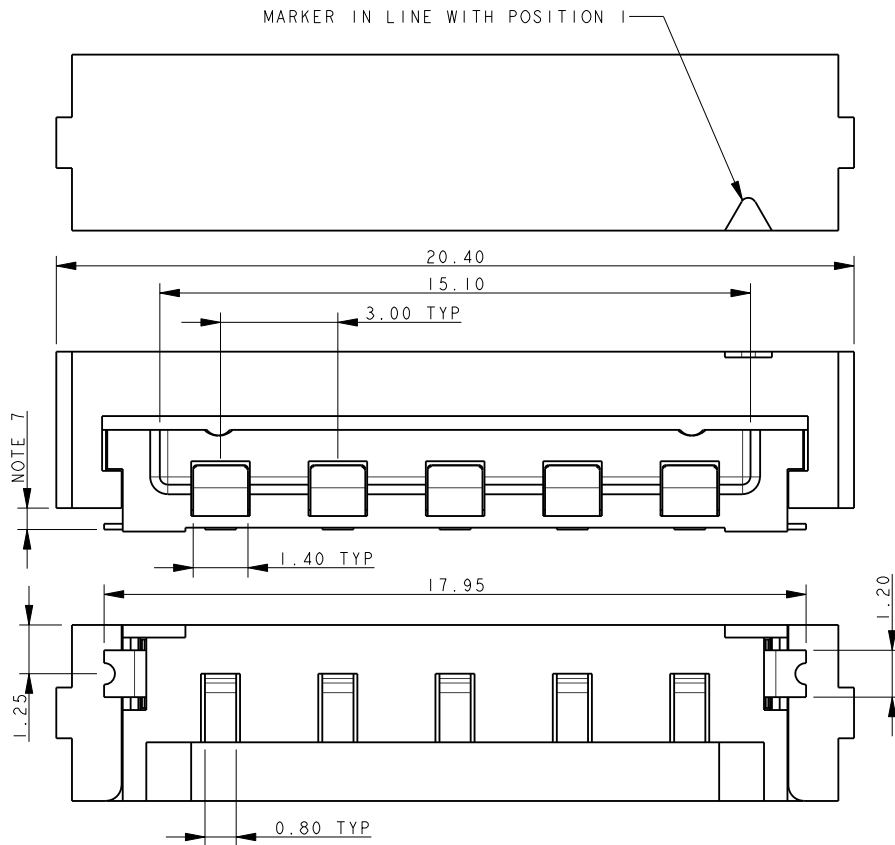

NOTES:

1. FOR MORE INFORMATION REFER TO PRODUCT SPEC 201-01-119.
2. DIMENSIONS ARE REFERENCE DIMENSIONS UNLESS TOLERANCES.
3. INSULATOR MATERIAL: NYLON 46. COLOR REFER TO PAGE 24.
4. CONTACT MATERIAL: COPPER ALLOY, GOLD OVER NICKEL.
5. BRACKETS: COPPER ALLOY, TIN PLATED.
6. OUTLINE OF CONNECTOR.
7. RESTRICTED COMPONENT HEIGHT UNDER CATCH, 2.20MM MAXIMUM.
8. RESTRICTED COMPONENT HEIGHT UNDER CATCH, 0.40MM MAXIMUM.
9. PACKING TAPE AND REEL, QUANTITY 1400 PER REEL.

5 WAY PCB BOARD LAYOUT

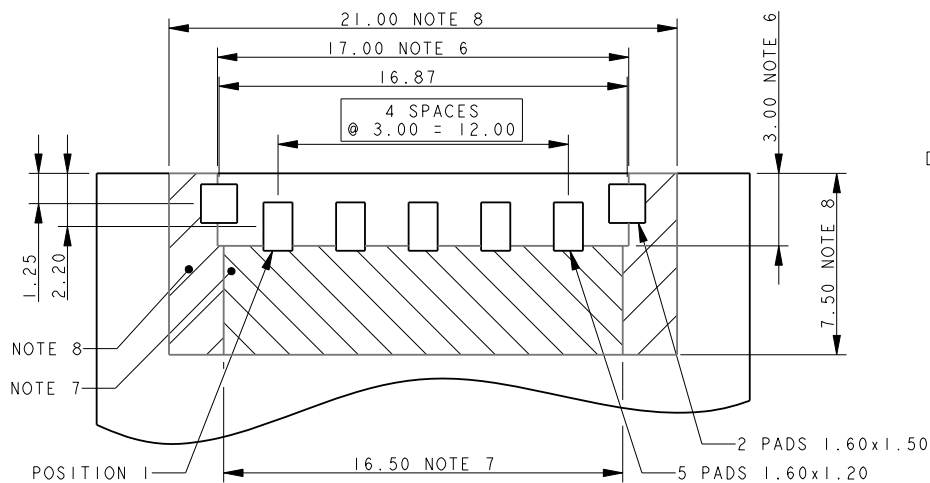

PACKING DETAILS

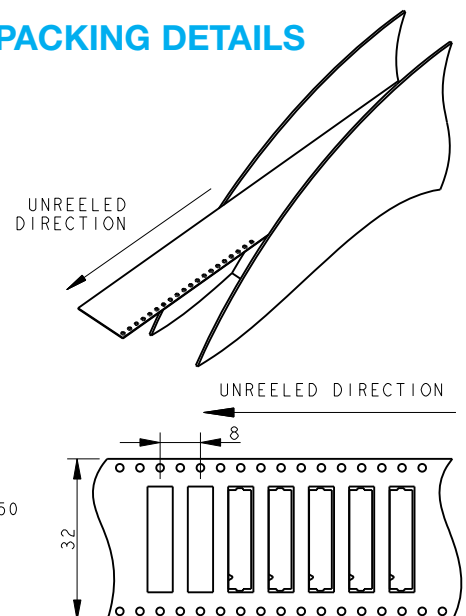

SSL - Top Load Socket



Series 9159

SOCKET TOP LOADING 6 WAY 2 PART PCB STRIP CONNECTOR

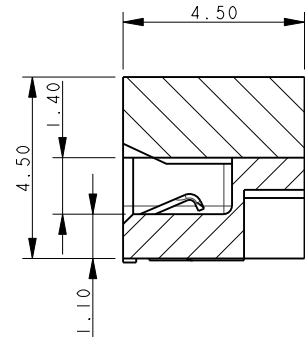
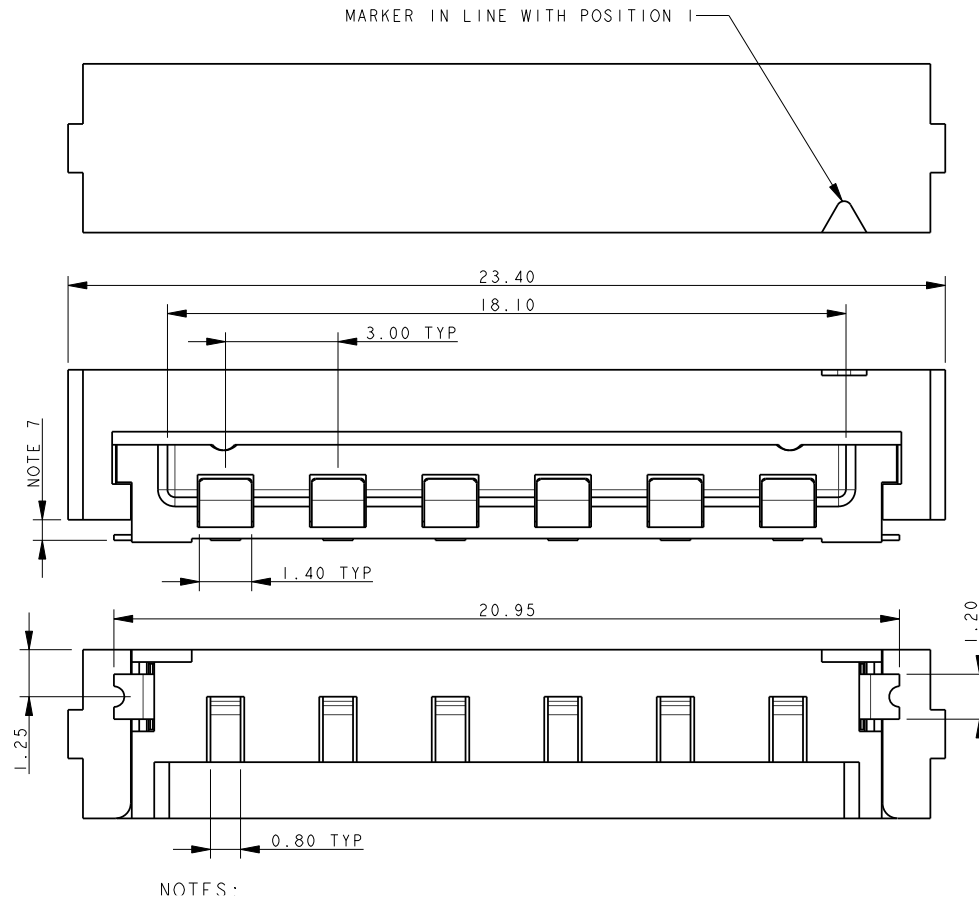

NOTES:

1. FOR MORE INFORMATION REFER TO PRODUCT SPEC 201-01-119.
2. DIMENSIONS ARE REFERENCE DIMENSIONS UNLESS TOLERANCES.
3. INSULATOR MATERIAL: NYLON 46. COLOR REFER TO PAGE 24.
4. CONTACT MATERIAL: COPPER ALLOY, GOLD OVER NICKEL.
5. BRACKETS: COPPER ALLOY, TIN PLATED.
6. OUTLINE OF CONNECTOR.
7. RESTRICTED COMPONENT HEIGHT UNDER CATCH, 2.20MM MAXIMUM.
8. RESTRICTED COMPONENT HEIGHT UNDER CATCH, 0.40MM MAXIMUM.
9. PACKING TAPE AND REEL, QUANTITY 1400 PER REEL.

6 WAY PCB BOARD LAYOUT

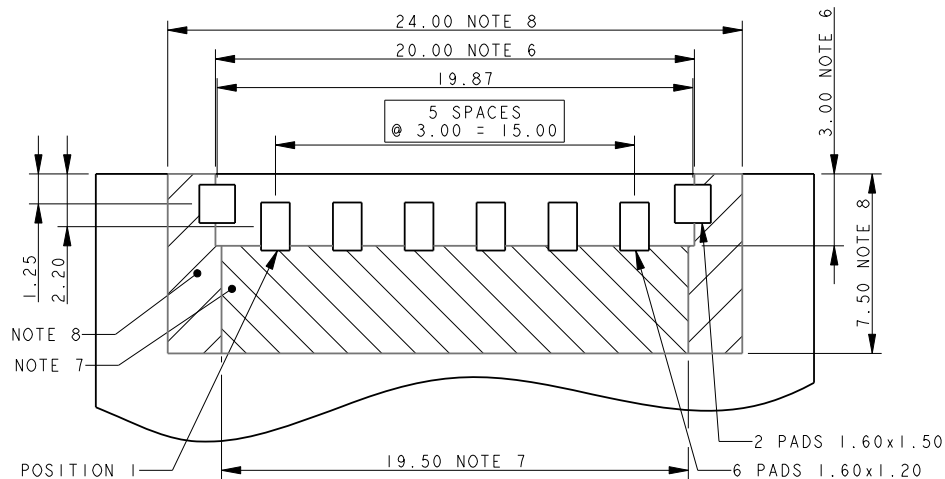

PACKING DETAILS

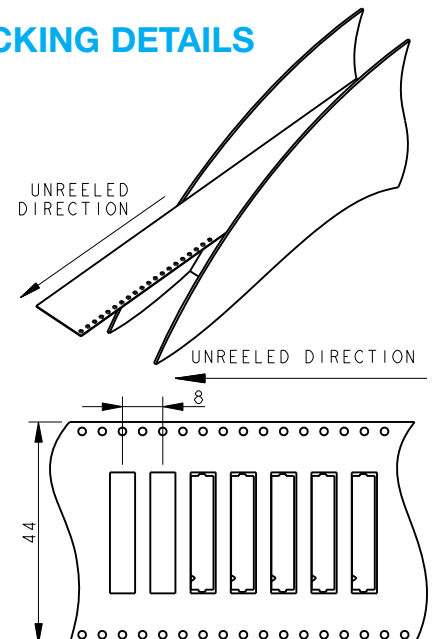

SSL - Top Load Socket

Series 9159



CONNECTOR ASSEMBLY



COVER FORWARD (LOCKED)



COVER SLID BACK



DROP PCB ASSEMBLY ONTO MATING CONNECTORS

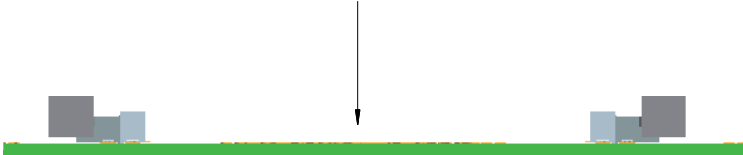



Компания «ЭлектроПласт» предлагает заключение долгосрочных отношений при поставках импортных электронных компонентов на взаимовыгодных условиях!

Наши преимущества:

- Оперативные поставки широкого спектра электронных компонентов отечественного и импортного производства напрямую от производителей и с крупнейших мировых складов;
- Поставка более 17-ти миллионов наименований электронных компонентов;
- Поставка сложных, дефицитных, либо снятых с производства позиций;
- Оперативные сроки поставки под заказ (от 5 рабочих дней);
- Экспресс доставка в любую точку России;
- Техническая поддержка проекта, помощь в подборе аналогов, поставка прототипов;
- Система менеджмента качества сертифицирована по Международному стандарту ISO 9001;
- Лицензия ФСБ на осуществление работ с использованием сведений, составляющих государственную тайну;
- Поставка специализированных компонентов (Xilinx, Altera, Analog Devices, Intersil, Interpoint, Microsemi, Aeroflex, Peregrine, Syfer, Eurofarad, Texas Instrument, Miteq, Cobham, E2V, MA-COM, Hittite, Mini-Circuits, General Dynamics и др.);

Помимо этого, одним из направлений компании «ЭлектроПласт» является направление «Источники питания». Мы предлагаем Вам помощь Конструкторского отдела:

- Подбор оптимального решения, техническое обоснование при выборе компонента;
- Подбор аналогов;
- Консультации по применению компонента;
- Поставка образцов и прототипов;
- Техническая поддержка проекта;
- Защита от снятия компонента с производства.



Как с нами связаться

Телефон: 8 (812) 309 58 32 (многоканальный)

Факс: 8 (812) 320-02-42

Электронная почта: org@eplast1.ru

Адрес: 198099, г. Санкт-Петербург, ул. Калинина, дом 2, корпус 4, литера А.