

Features

- ◆ Ultra wide 4:1 input voltage range
- ◆ Single output voltage models from 1.8 to 15 VDC
- ◆ Dual output voltage models
- ◆ Extended operating temperature range: -40°C to 85°C
- ◆ Under voltage lockout
- ◆ Remote On/Off
- ◆ Shielded metal case with insulated baseplate
- ◆ Optional heatsink
- ◆ Lead free design - RoHS compliant
- ◆ 3-year product warranty

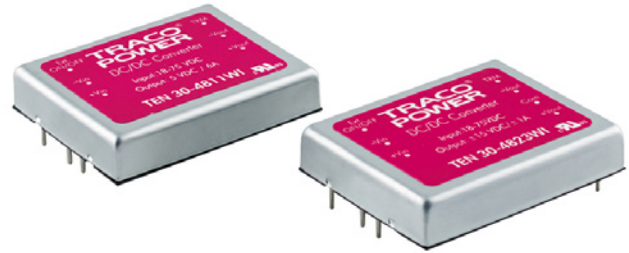

The TEN 30WI series is a family of high performance 30W dc-dc converters featuring ultra wide 4:1 input voltage ranges in a compact low profile package with industry-standard footprint. A very high efficiency allows operating temperatures up to 85°C. A built-in filter for both input and output minimizes the need for external filtering. Further standard features include remote On/Off, output voltage trimming, over voltage protection, under voltage lockout and short circuit protection. Typical applications for these products are battery operated equipment and distributed power architectures in communication and industrial electronics, everywhere where isolated, tightly regulated voltages are required and space is limited on the PCB.

Models

Order code	Input voltage range	Output voltage	Output current max.	Efficiency typ.
TEN 30-2408WI	10 – 40 VDC (nominal 24 VDC)	1.8 VDC	8'000 mA	80 %
TEN 30-2409WI		2.5 VDC	8'000 mA	85 %
TEN 30-2410WI		3.3 VDC	6'000 mA	87 %
TEN 30-2411WI		5.0 VDC	6'000 mA	87 %
TEN 30-2412WI		12 VDC	2'500 mA	87 %
TEN 30-2413WI		15 VDC	2'000 mA	88 %
TEN 30-2422WI		±12 VDC	±1'250 mA	85 %
TEN 30-2423WI		±15 VDC	±1'000 mA	86 %
TEN 30-4808WI	18 – 75 VDC (nominal 48 VDC)	1.8 VDC	8'000 mA	81 %
TEN 30-4809WI		2.5 VDC	8'000 mA	86 %
TEN 30-4810WI		3.3 VDC	6'000 mA	87 %
TEN 30-4811WI		5.0 VDC	6'000 mA	88 %
TEN 30-4812WI		12 VDC	2'500 mA	87 %
TEN 30-4813WI		15 VDC	2'000 mA	88 %
TEN 30-4822WI		±12 VDC	±1'250 mA	86 %
TEN 30-4823WI		±15 VDC	±1'000 mA	87 %

Input Specifications

Input current at no load (nominal input 24/48 Vin)	1.8 Vout models: 35 / 20 mA typ. 2.5/3.3 Vout models: 40 / 25 mA typ. other models: 70 / 45 mA typ.
Input current at full load (nominal input 24/48 Vin)	1.8 Vout models: 760 / 380 mA typ. 2.5/3.3 Vout models: 1030 / 510 mA typ. other models: 1500 / 750 mA typ.
Input voltage variation (dv/dt)	5 V/ms, max. (complies with ETS 300 132 part. 4.4)
Start-up voltage / under voltage lockout	24 Vin models: 10 VDC / 8 VDC (typ.) 48 Vin models: 18 VDC / 16 VDC (typ.)
Surge voltage (100 msec. max.)	24 Vin models: 50 V max. 48 Vin models: 100 V max.
Conducted noise (input)	EN 55022 level A, FCC part 15, level A with external capacitor (see note 1)
ESD (input)	EN 61000-4-2, perf. criteria B
Fast transient (input)	EN 61000-4-4, perf. criteria A
Surge (input)	EN 61000-4-5, perf. criteria B

Output Specifications

Voltage set accuracy	±1 %
Output voltage adjustment	±10 %
Regulation	– Input variation Vin min. to Vin max. ±0.5 % max. – Load variation 10 – 100 %: single output models: ±0.5 % max. dual output models: ±1.0 % max. (balanced load) ±5 % max. (Load cross variation 25 % / 100 %)
Temperature coefficient	±0.02 %/K
Ripple and noise (20 MHz Bandwidth):	75 mVpk-pk max.
Start up time (nominal Vin and constant resistive load)	10 ms typ.
Transient response setting time (25% load step change)	300 µs typ.
Short circuit protection	indefinite (automatic recovery)
Over load protection	150 % of Iout max typ. foldback
Thermal shutdown	at +115°C typ
Over voltage protection	1.8, 2.5 & 3.3 V output models: 3.9 V 5.0 V output models: 6.2 V 12 V output models: 15 V 15 V output models: 18 V
Minimum load (only for dual output models)	10% of rated max current (operation at lower load condition will not damage these converters, however, they may not meet all listed specifications)
Capacitive load	1.8 / 2.5 Vout models: 65'000 µF max./ 33'000 µF max. 3.3 / 5.0 Vout models: 19'500 µF max./ 10'200 µF max. 12 / 15 Vout models: 3'300 µF max./ 1'100 µF max. ±12 / ±15 Vout models: ±1'000 µF max./ ±680 µF max. (per output)

All specifications valid at nominal input voltage, full load and +25°C after warm-up time unless otherwise stated.

General Specifications

Temperature ranges	- Operating - Case temperature - Storage	-40°C to +85°C +100°C max. -55°C to +105°C
Thermal impedance	- with heat-sink TEN-HS2 - without heat-sink	8.24 K/Watt 10 K/Watt
Derating		www.tracopower.com/products/ten30wi-derating.pdf
Humidity (non condensing)		95 % rel H max.
Reliability, calculated MTBF (MIL-HDBK-217F, at +25°C, ground benign)		>750'000 h
Isolation voltage (60sec.)	- Input / Output	1'500 VDC
Isolation resistance	- Input / Output	>1'000 M Ohm
Isolation capacitance	- Input / Output	1000 pF max.
Remote On/Off	- On: - Off: - Off idle current:	3.5 ... 12 VDC or open circuit. 0 ... 1.2 VDC or short circuit pin 3 and pin 2 3 mA typ.
Switching frequency		300 kHz typ. (pulse width modulation PWM)
Vibration		10-55 Hz, 2G, 30 minutes along X,Y,Z
Safety standards		UL 60950, IEC/EN 60950, compliance up to 60 VDC input voltage (SELV limit)
Safety approvals	- UL/cUL	www.ul.com > UL File no.: e188913
Environmental compliance	- Reach - RoHS	www.tracopower.com/products/ten30wi-reach.pdf RoHS directive 20011/65/EU

Note 1:

In order to meet conducted emissions EN55022-A and EN55011-A a capacitor between +Vin and -Vin has to be installed. The capacitor should be capable to handle 1 A ripple current. A suggestion is KMF Series of Nippon chemi-con, 220µF/100V, ESR 90mOhm.

Output Voltage Adjustment

Trim up

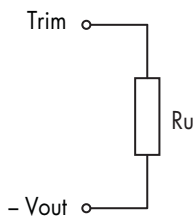

Ru [kohm]*

output	1.8V	2.5V	3.3V	5.0V
+5%	1.2	4.3	6.8	4.7
+10%	0.068	0.82	1.5	0.56
output	12V	15V	±12V	±15V
+5%	47	47	27	33
+10%	8.2	6.8	2.2	2.7

Trim down

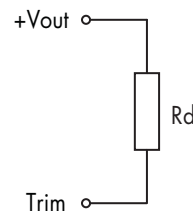

Ru [kohm]*

output	1.8V	2.5V	3.3V	5.0V
-5%	1.8	6.8	8.2	5.6
-10%	0.1	0.82	0.68	0.68
output	12V	15V	±12V	±15V
-5%	56	56	33	39
-10%	5.6	2.2	2.7	3.3

*approximate values

All specifications valid at nominal input voltage, full load and +25°C after warm-up time unless otherwise stated.

Physical Specifications

Casing material	copper, nickel plated
Baseplate material	none conductive FR4
Potting material	epoxy (UL 94V-0 -rated)
Weight	48 g (1.69 oz)
Soldering temperature	max. 265°C / 10 sec.

Outline Dimensions

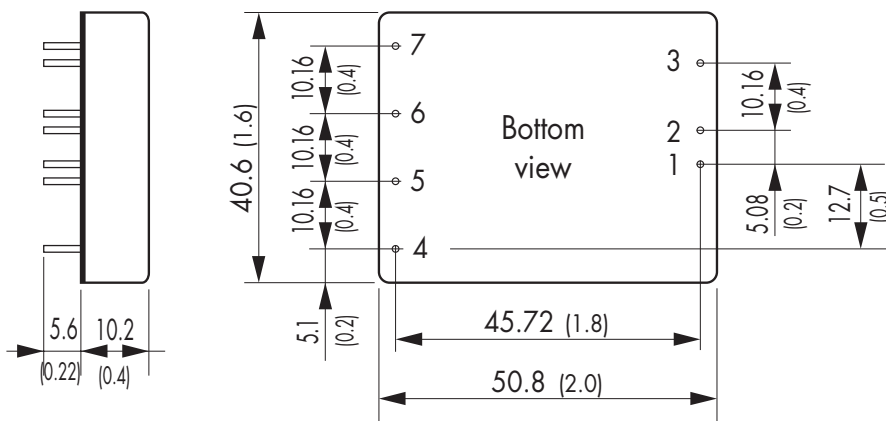

Pin-Out		
Pin	Single	Dual
1	+Vin (Vcc)	+Vin (Vcc)
2	-Vin (GND)	-Vin (GND)
3	Remote On/Off	
4	No pin	+Vout
5	+Vout	Common
6	-Vout	-Vout
7	Trim	

Dimensions in [mm], () = Inch
 Pin diameter: 1.0 ±0.05 (0.02 ±0.002)
 Pin pitch tolerances: ±0.35 (±0.014)
 Case tolerances: ±0.5 (±0.02)

Heat-sink TEN-HS2

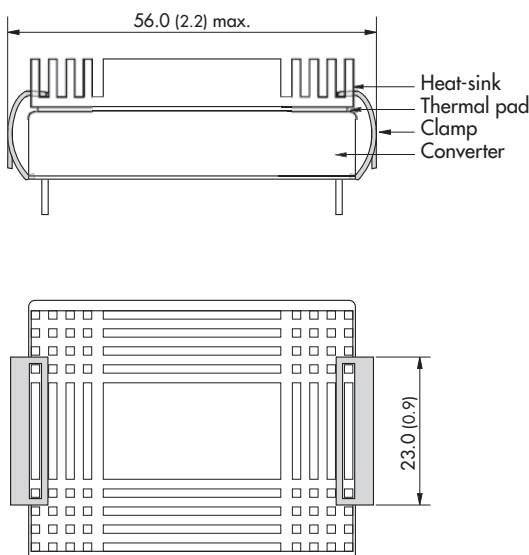

Order code: TEN-HS2
 (cont.: heat-sink, thermal pad, 2 clamps)
Material: Aluminum
Finish: Anodic treatment (black)
Weight: 19 g (0.67oz) (without converter)

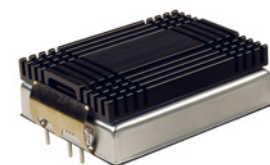

3D step file: www.tracopower.com/products/ten30wi-3d.stp

Note:
 The product label on converter has to be removed before mounting the heat-sink. For volume orders converters will be supplied with heat-sinks already mounted. Please contact factory for quotation. Separate heat-sinks are only available for prototypes and small quantity orders.

Specifications can be changed without notice! Make sure you are using the latest documentation, downloadable at www.tracopower.com



Компания «ЭлектроПласт» предлагает заключение долгосрочных отношений при поставках импортных электронных компонентов на взаимовыгодных условиях!

Наши преимущества:

- Оперативные поставки широкого спектра электронных компонентов отечественного и импортного производства напрямую от производителей и с крупнейших мировых складов;
- Поставка более 17-ти миллионов наименований электронных компонентов;
- Поставка сложных, дефицитных, либо снятых с производства позиций;
- Оперативные сроки поставки под заказ (от 5 рабочих дней);
- Экспресс доставка в любую точку России;
- Техническая поддержка проекта, помощь в подборе аналогов, поставка прототипов;
- Система менеджмента качества сертифицирована по Международному стандарту ISO 9001;
- Лицензия ФСБ на осуществление работ с использованием сведений, составляющих государственную тайну;
- Поставка специализированных компонентов (Xilinx, Altera, Analog Devices, Intersil, Interpoint, Microsemi, Aeroflex, Peregrine, Syfer, Eurofarad, Texas Instrument, Miteq, Cobham, E2V, MA-COM, Hittite, Mini-Circuits, General Dynamics и др.);

Помимо этого, одним из направлений компании «ЭлектроПласт» является направление «Источники питания». Мы предлагаем Вам помощь Конструкторского отдела:

- Подбор оптимального решения, техническое обоснование при выборе компонента;
- Подбор аналогов;
- Консультации по применению компонента;
- Поставка образцов и прототипов;
- Техническая поддержка проекта;
- Защита от снятия компонента с производства.



Как с нами связаться

Телефон: 8 (812) 309 58 32 (многоканальный)

Факс: 8 (812) 320-02-42

Электронная почта: org@eplast1.ru

Адрес: 198099, г. Санкт-Петербург, ул. Калинина, дом 2, корпус 4, литера А.