

# General Specifications

Toggles

Rockers

Pushbuttons

Illuminated PB

Programmable

Keylocks

Rotaries

Slides

Tactiles

Tilt

Touch

Indicators

Accessories

Supplement

**B CWSA****Electrical Capacity****Power Level:** For Resistive Load 6A @ 250V AC**Other Ratings****Contact Resistance:** 20 milliohms maximum**Insulation Resistance:** 500 megohms minimum @ 500V DC**Dielectric Strength:** 1,500V AC minimum between contacts for 1 minute minimum  
3,000V AC minimum between contacts & case for 1 minute minimum**Mechanical Life:** 30,000 operations minimum**Electrical Life:** 10,000 operations minimum with Resistive Load & 6,000 operations with Inductive Load**Nominal Operating Force:** 2.50N**Angle of Throw:** 30°**Operating Temperature Range:** -10°C ~ +70°C (+14°F ~ +158°F)**Materials & Finishes****Rocker:** Polycarbonate**Housing:** Polyamide**Movable Contactor:** Brass w/silver alloy plating**Movable Contacts:** Silver**Stationary Contacts:** Silver alloy**Base:** Laminated thermosetting sheets**Contact Terminals:** Copper with silver plating**Common Terminals:** Brass with silver plating**CWSB****Electrical Capacity****Power Level:** For Resistive Load 6A @ 250V AC**Other Ratings****Contact Resistance:** 20 milliohms maximum**Insulation Resistance:** 500 megohms minimum @ 500V DC**Dielectric Strength:** 1,500V AC minimum between contacts for 1 minute minimum  
3,000V AC minimum between contacts & case for 1 minute minimum**Mechanical Life:** 30,000 operations minimum**Electrical Life:** 10,000 operations minimum with Resistive Load & 6,000 operations with Inductive Load**Nominal Operating Force:** 6.50N for single pole models; 10.0N for double pole models**Angle of Throw:** 30°**Operating Temperature Range:** -10°C ~ +70°C (+14°F ~ +158°F)**Materials & Finishes****Rocker:** Polycarbonate**Housing:** Polyamide**Movable Contactor:** Beryllium copper w/silver alloy plating**Movable Contacts:** Silver**Stationary Contacts:** Silver alloy**Base:** Laminated thermosetting sheets**Terminals:** Brass with silver plating**CWT****Electrical Capacity****Power Level:** For Resistive Load 6A @ 125V AC; 3A @ 250V AC; 4A @ 30V DC**Other Ratings****Contact Resistance:** 20 milliohms maximum**Insulation Resistance:** 1,000 megohms minimum @ 500V DC**Dielectric Strength:** 1,000V AC minimum between contacts for 1 minute minimum  
1,500V AC minimum between contacts & case for 1 minute minimum**Mechanical Life:** 50,000 operations minimum**Electrical Life:** 25,000 operations minimum**Nominal Operating Force:** 2.0N**Angle of Throw:** 30°**Operating Temperature Range:** -25°C ~ +70°C (-13°F ~ +158°F)**Materials & Finishes****Rocker:** Glass fiber reinforced polyamide**Housing:** Polyamide**Movable Contactor:** Phosphor bronze w/silver plating**Movable Contacts:** Silver alloy**Base:** LCP (Liquid Crystal Polymer)**Contact Terminals:** Brass + silver with silver plating**Common Terminals:** Brass with silver plating

# Distinctive Characteristics

## CWSA

- Low cost molded rocker.
- See-saw contact mechanism
- Stable stationary contact construction for high reliability.
- Easily installed with snap-in mounting.
- Large terminal hole dimensioned .067" x .098" (1.7mm x 2.5mm) simplifies wiring and soldering.
- Wave Soldering (PC version): See Profile A in Supplement section.
- Manual Soldering: See Profile A in Supplement section.



## CWSB

- Low cost molded rocker.
- Snap-acting contact mechanism gives smooth actuation and audible feedback.
- Stable stationary contact construction for high reliability.
- Front panel, snap-in mounting for labor-saving installation.
- Solder lug/quick connect terminals can be used with connectors.
- Manual Soldering: See Profile B in Supplement section.

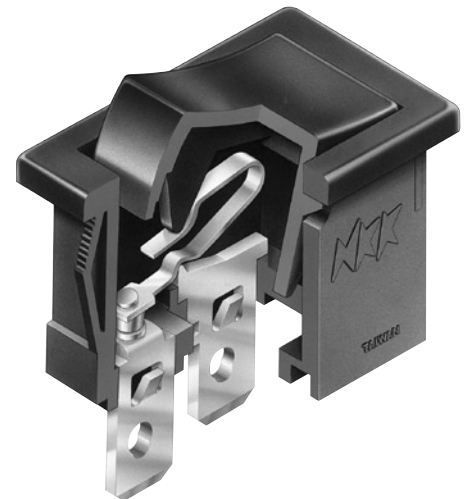

## CWT

- Low cost molded rocker in compact, slim design.
- See-saw contact mechanism
- Outstanding insulation resistance and dielectric strength.
- Dust proof construction protects contact area.
- Stable stationary contact construction for high reliability.
- Front panel, snap-in mounting for labor-saving installation.
- Terminals are molded in and epoxy sealed to lock out flux, dust, and other contaminants.
- Manual Soldering: See Profile A in Supplement section.

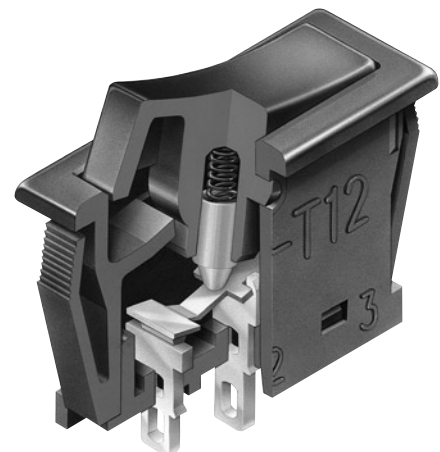

- Toggle
- B** Rockers
- Pushbuttons
- Illuminated PB
- Programmable
- Keylocks
- Rotaries
- Slides
- Tactiles
- Tilt
- Touch
- Indicators
- Accessories
- Supplement

## STANDARDS & CERTIFICATIONS

### CWSA



Specific CWSA models listed below are qualified for Underwriters Laboratories Inc. recognition and Canadian Standards Association certification. cULus marking on case is standard as noted in following table.

<u>Model</u>	<u>Ratings @ AC</u>	<u>cULus File No.</u>	<u>Marking on Case</u>
CWSA11	6A @ 250V	E44145	Standard
CWSA12	6A @ 250V	E44145	Standard

### CWSB



Specific CWSB models listed below are qualified for Underwriters Laboratories Inc. recognition and Canadian Standards Association certification. cULus marking on case is standard as noted in following table.

<u>Model</u>	<u>Ratings @ AC</u>	<u>cULus File No.</u>	<u>Marking on Case</u>
CWSB11	6A @ 250V	E44145	Standard
CWSB21	6A @ 250V	E44145	Standard

### CWT



Specific CWT model listed below is qualified for Underwriters Laboratories Inc. recognition and Canadian Standards Association certification. cULus marking on case is standard as noted in following table.

<u>Model</u>	<u>Ratings @ AC</u>	<u>cULus File No.</u>	<u>Marking on Case</u>
CWT12	6A @ 125V 3A @ 250V	E44145	Standard

Toggles

Rockers **B**

Pushbuttons

Illuminated PB

Programmable

Keylocks

Rotaries

Slides

Tactiles

Tilt

Touch

Indicators

Accessories

Supplement

TYPICAL SWITCH ORDERING EXAMPLES

**CWSA** **1** **1** **A** **A** **N** **S**

Pole	
1	SPST & SPDT

Circuits			
1	ON	NONE	OFF
2	ON	NONE	ON

Cap Color	
A	Black

Housing	
A	Black

Inscription	
For SPST & SPDT	
No Code	None
For SPST	
1	Horizontal
2	Vertical
3	Dot Marking

Terminals	
S	Solder Lug*
H	Right Angle PC

**TYPICAL ORDERING EXAMPLE**  
**CWSA11AANS**



\* Wire harness & cable assemblies offered only in Americas

**CWSB** **2** **1** **A** **A** **2** **F**

Poles	
1	SPST
2	DPST

Circuit			
1	ON	NONE	OFF

Cap Color	
A	Black

Housing	
A	Black

Inscription	
No Code	None (SPST only)
1	Horizontal
2	Vertical
3	Dot Marking (SPST only)

Terminals	
F	Quick Connect*
H	Right Angle PC

**TYPICAL ORDERING EXAMPLE**  
**CWSB21AA2F**



\* Wire harness & cable assemblies offered only in Americas

**CWT** **1** **2** **A** **A** **S1**

Pole	
1	SPDT

Circuit			
2	ON	NONE	ON

Cap Color	
A	Black

Housing	
A	Black

Terminals	
S1	Solder Lug*

**TYPICAL ORDERING EXAMPLE**  
**CWT12AAS1**



\* Wire harness & cable assemblies offered only in Americas

## INSCRIPTIONS

**No Code**

**None**

Not available in double pole.

**1**

**Horizontal Orientation**

Only On-None-Off models are available with the horizontal inscription.

**2**

**Vertical Orientation**

Only On-None-Off models are available with the vertical inscription.

**3**

**Dot Marking**

Only Single Pole On-None-Off models are available with the dot inscription.



The IEC symbols for On-Off are supplied with Single Throw models only. Orientation of inscription must be selected. Inscription color is white ink on black.

## TYPICAL SWITCH DIMENSIONS FOR CWSA

**Solder Lug**

**Single Pole • No Inscription**

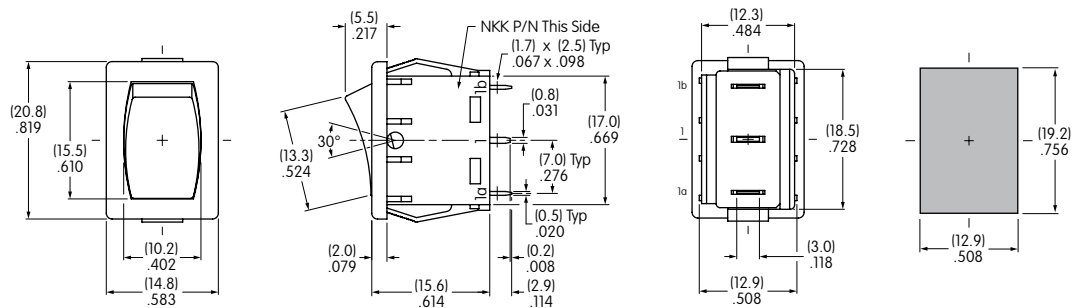

Terminal numbers are on side of switch body

Panel Thickness .030" ~ .079" (0.75mm ~ 2.0mm)

**CWSA12AANS**

**Right Angle**

**Single Pole • Horizontal On-Off Inscription**

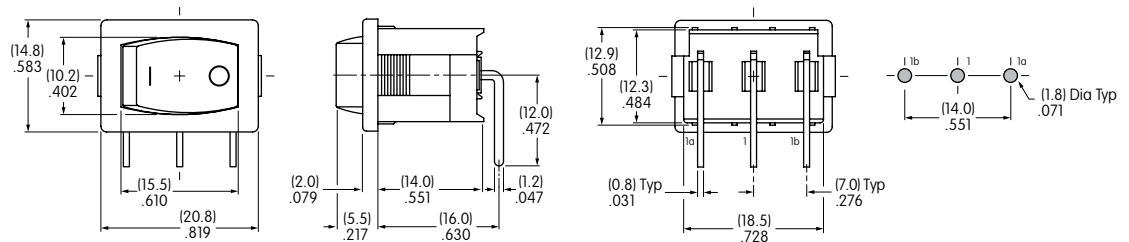

Single throw model does not have terminal 1b

Terminal numbers are on side of switch body

**CWSA11AAN1H**

TYPICAL SWITCH DIMENSIONS FOR CWSB

Double Pole • Vertical On-Off Inscription

Quick Connect

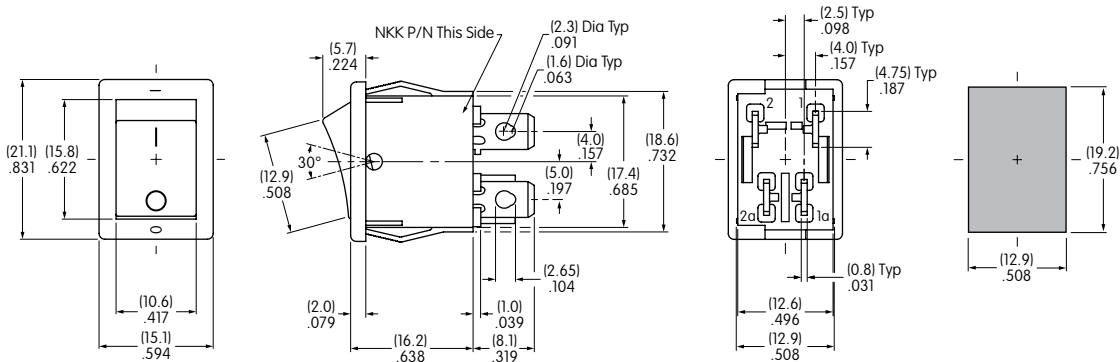

Terminal numbers are on bottom of switch

Panel Thickness  
.030" ~ .079"  
(0.75mm ~ 2.0mm)

CWSB21AA2F



Single Pole • Dot Inscription

Right Angle

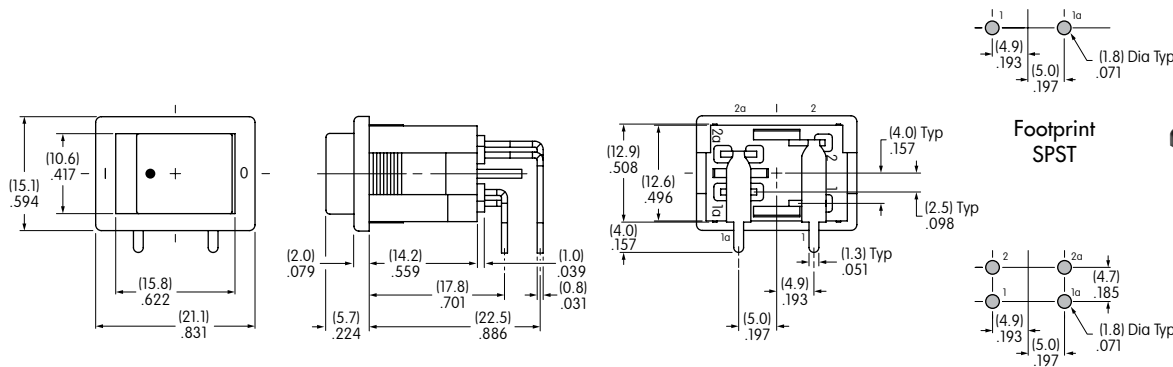

Terminal numbers are on bottom of switch

Footprint  
SPST

Footprint  
DPST

CWSB11AA3H



TYPICAL SWITCH DIMENSIONS FOR CWT

Single Pole • No Inscription

Solder Lug

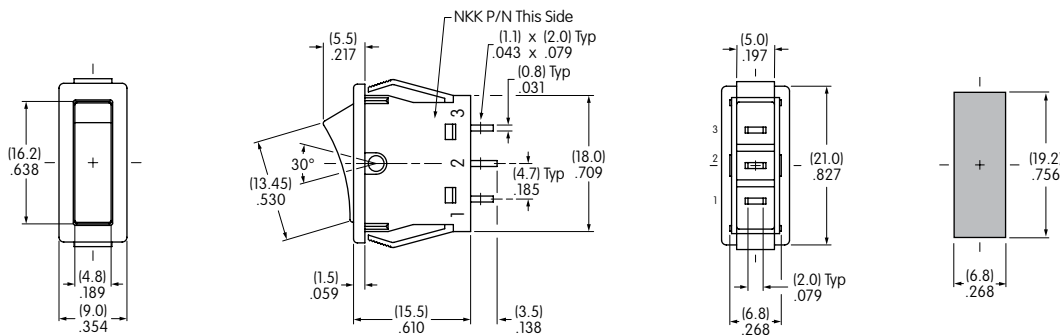

Terminal numbers are on side of switch body

Panel Thickness  
.030" ~ .079"  
(0.75mm ~ 2.0mm)

CWT12AAS1





Компания «ЭлектроПласт» предлагает заключение долгосрочных отношений при поставках импортных электронных компонентов на взаимовыгодных условиях!

Наши преимущества:

- Оперативные поставки широкого спектра электронных компонентов отечественного и импортного производства напрямую от производителей и с крупнейших мировых складов;
- Поставка более 17-ти миллионов наименований электронных компонентов;
- Поставка сложных, дефицитных, либо снятых с производства позиций;
- Оперативные сроки поставки под заказ (от 5 рабочих дней);
- Экспресс доставка в любую точку России;
- Техническая поддержка проекта, помощь в подборе аналогов, поставка прототипов;
- Система менеджмента качества сертифицирована по Международному стандарту ISO 9001;
- Лицензия ФСБ на осуществление работ с использованием сведений, составляющих государственную тайну;
- Поставка специализированных компонентов (Xilinx, Altera, Analog Devices, Intersil, Interpoint, Microsemi, Aeroflex, Peregrine, Syfer, Eurofarad, Texas Instrument, Miteq, Cobham, E2V, MA-COM, Hittite, Mini-Circuits, General Dynamics и др.);

Помимо этого, одним из направлений компании «ЭлектроПласт» является направление «Источники питания». Мы предлагаем Вам помощь Конструкторского отдела:

- Подбор оптимального решения, техническое обоснование при выборе компонента;
- Подбор аналогов;
- Консультации по применению компонента;
- Поставка образцов и прототипов;
- Техническая поддержка проекта;
- Защита от снятия компонента с производства.



#### Как с нами связаться

**Телефон:** 8 (812) 309 58 32 (многоканальный)

**Факс:** 8 (812) 320-02-42

**Электронная почта:** [org@eplast1.ru](mailto:org@eplast1.ru)

**Адрес:** 198099, г. Санкт-Петербург, ул. Калинина, дом 2, корпус 4, литера А.