

Crystal Units/Crystal Oscillators

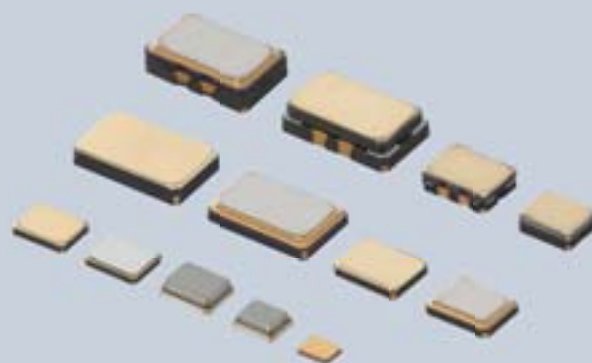



EU RoHS Compliant

- All the products in this catalog comply with EU RoHS.
- EU RoHS is "the European Directive 2011/65/EU on the Restriction of the Use of Certain Hazardous Substances in Electrical and Electronic Equipment."
- For more details, please refer to our website 'Murata's Approach for EU RoHS' (<http://www.murata.com/en-eu/support/compliance/rohs>).

Contents

Product specifications are as of December 2015.

Bluetooth® is a registered trademark or trademark of Bluetooth SIG, Inc. in the United States and other countries.

Selection Guide	p2
Part Numbering	p3
<hr/>	
1 Crystal Units for Consumer	
Features, Applications	p5
Appearance, Dimension	p5
Part Number List	p6
Standard Land Pattern Dimensions	p8
Notice	p10
Packaging	p12
<hr/>	
2 Crystal Units for Automotive	
Features, Applications	p15
Appearance, Dimension	p15
Part Number List	p16
Standard Land Pattern Dimensions	p16
Notice	p17
Packaging	p19
<hr/>	
3 Crystal Units for Industrial	
Features, Applications	p20
Appearance, Dimension	p20
Part Number List	p21
Standard Land Pattern Dimensions	p22
Notice	p23
Packaging	p25
<hr/>	
4 Crystal Oscillators for Industrial	
Features, Applications	p28
Appearance, Dimension	p28
Part Number List	p29
Standard Land Pattern Dimensions	p30
Notice	p31
Packaging	p33
<hr/>	
Measuring Circuit of Crystal Units	p35

Please check the MURATA website (<http://www.murata.com/>) if you cannot find a part number in this catalog.

Selection Guides

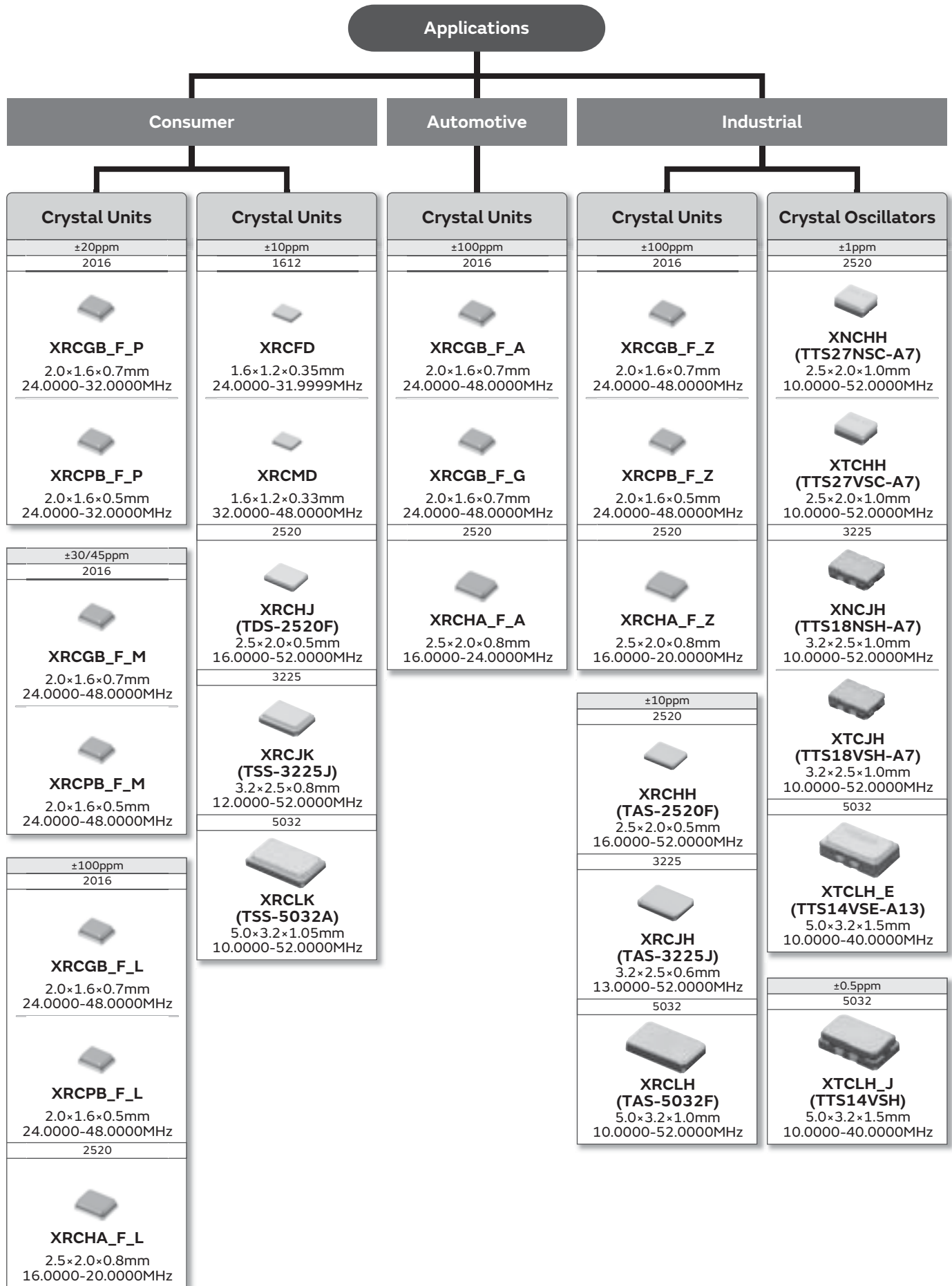

● Part Numbering

Crystal Unit

(Part Number)

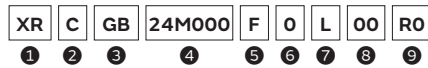

① Product ID

Product ID	
XR	Crystal Unit

② Lead Style

Code	Lead Style
C/T	SMD

③ Size · Structure

Code	Size · Structure
FD	1612 (STD) Metal Sealing
MD	1612 (Low Profile) Metal Sealing
GB	2016 (STD) Resin Sealing
PB	2016 (Low Profile) Resin Sealing
HA	2520 Resin Sealing
HH	2520 Metal Sealing
HJ	2520 Seam Sealing
JH	3225 Metal Sealing
JK	3225 Seam Sealing
LH	5032 Metal Sealing
LK	5032 Seam Sealing

④ Nominal Center Frequency

Expressed by six-digit alphanumeric. The unit is in hertz (Hz).
 Decimal point is expressed by capital letter "M".

⑤ Overtone Order

Code	Overtone Order
F	Fundamental
K	Customized Fundamental

⑥ Frequency Tolerance

Code	Frequency Tolerance
0	±100ppm
1	±10ppm
2	±20ppm
3	±30ppm
4	±45ppm/±40ppm* ¹
5	±50ppm
A	±25ppm/±15ppm* ²
Y	Total* ³ ±20ppm

*1 *2 When ③ is "HH" or "JK"

*3 Including Initial Tolerance+Temperature Characteristics+Aging+Reflow

⑦ Frequency Shift by Temperature

Code	Frequency Shift by Temperature
A	±100ppm max. (Automotive Grade)
G	±50ppm (Car Multimedia Grade)
L	±50ppm min.
M	±40ppm
N	±25ppm or 30ppm
P	±20ppm
Q	±10ppm to ±15ppm/±10ppm to ±19ppm* ¹
Z	±100ppm (for Industrial)

*1 When ③ is "HH" or "JK"

⑧ Individual Specification

Code	
**	Two-digit alphanumerics express Individual Specification.

00: Standard specification type.

⑨ Packaging (Quantity and Plastic taping reel diameter are expressed by one-digit number in "**")

Code	Packaging
R*/E*/J*/P*	Plastic Taping

Crystal Oscillator

(Part Number)

XN	C	HH	19M200	T	J	E	A5	P0
①	②	③	④	⑤	⑥	⑦	⑧	⑨

① Product ID

Product ID	
XT	VC-TCXO
XN	TCXO

② Lead Style

Code	Lead Style
C	SMD

③ Size · Structure

Code	Size · Structure
HH	2520 Metal Sealing
JH	3225 Metal Sealing
LH	5032 Metal Sealing

④ Nominal Center Frequency

Expressed by six-digit alphanumeric. The unit is in hertz (Hz).
 Decimal point is expressed by capital letter "M".

⑤ Output Wave

Code	Output Wave
T	Clipped Sign Wave

⑥ Frequency Tolerance

Code	Frequency Tolerance
J	±1.0 to ±1.4ppm

⑦ Frequency Shift by Temperature

Code	Frequency Shift by Temperature
E	±0.5ppm max.
J	Less than ±0.3ppm

⑧ Individual Specification

Code	
**	Two-digit alphanumerics express Individual Specification.

⑨ Packaging (Quantity and Plastic taping reel diameter are expressed by one-digit number in "**")

Code	Packaging
E*/G*/P*	Plastic Taping

Crystal Units

for Consumer

RoHS Lead free

1

These crystal units feature a small package and highly accurate frequency, based on Murata's excellent package technology and high grade quartz crystal elements.

Features

1. This series is ideal for applications requiring high accuracy crystal units, especially communication clocks such as GPS, Wi-Fi, B.T. (Bluetooth®), BLE (Bluetooth® Low Energy), SATA and USB3.0.
2. The crystal units are extremely small, contributing to a reduction in the mounting area.
3. The series complies to RoHS directive, being lead-free (phase 3).

Applications

1. Clock for GPS controller ICs:
 smartphone, wearable equipment, module, etc.
2. Clock for Wi-Fi, B.T. and ACPU controller ICs:
 smartphone, wearable device, module, etc.
3. Clock for BLE controller ICs:
 wearable, fitness and healthcare devices, module, etc.
4. Storage devices with SATA interface:
 HDD, SSD, Optical storage device, etc.
5. Clock for USB (Ultra-Speed and High-Speed) controller ICs: Mobile phone, DVC, DSC, Portable audio, PC peripheral, etc.
6. Clock for PC, visual equipment controller ICs
7. Audio equipment and musical instrument, etc.
8. Other applications for replacement of other crystal units or oscillators.

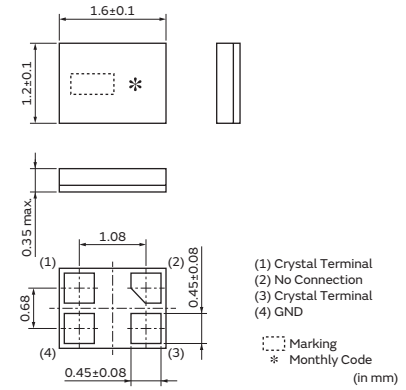

XRCFD
 24.0000–31.9999MHz



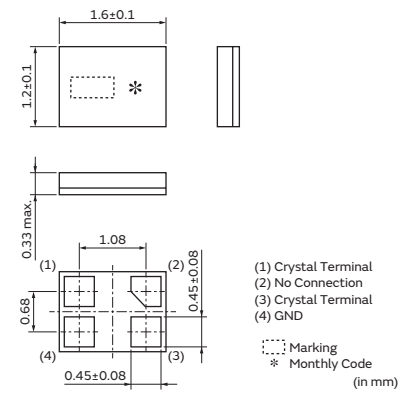

XRCMD
 32.0000–48.0000MHz

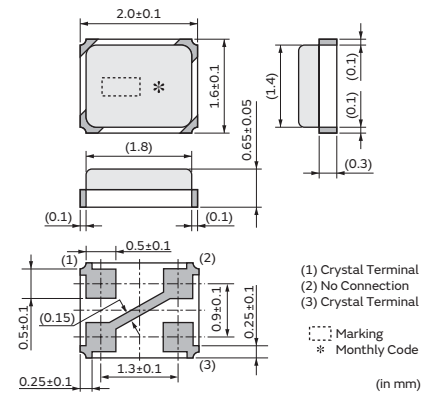

XRCGB_F_P
 24.0000–32.0000MHz
XRCGB_F_L/M
 24.0000–48.0000MHz



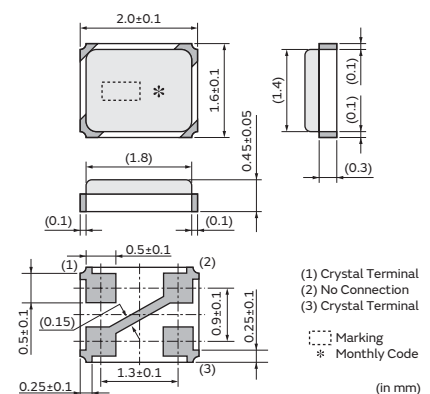

XRCPB_F_P
 24.0000–32.0000MHz
XRCPB_F_L/M
 24.0000–48.0000MHz



Continued on the following page. ↗

Continued from the preceding page. ↘

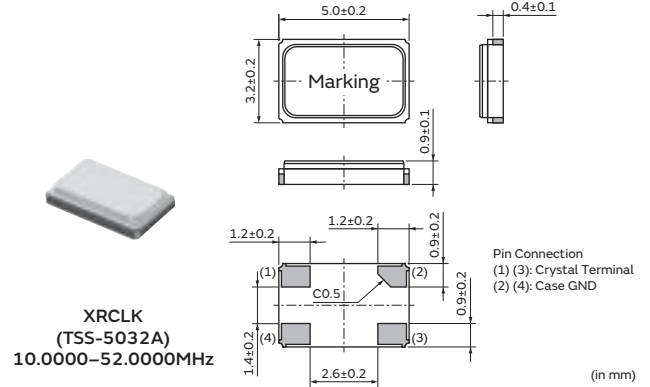
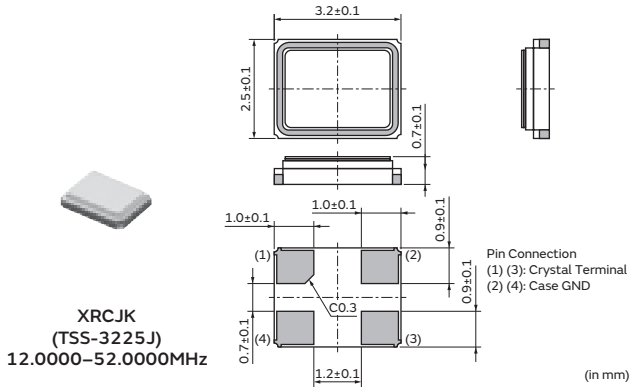
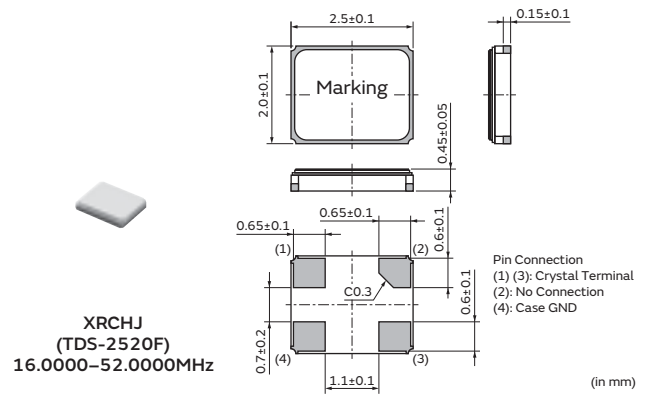
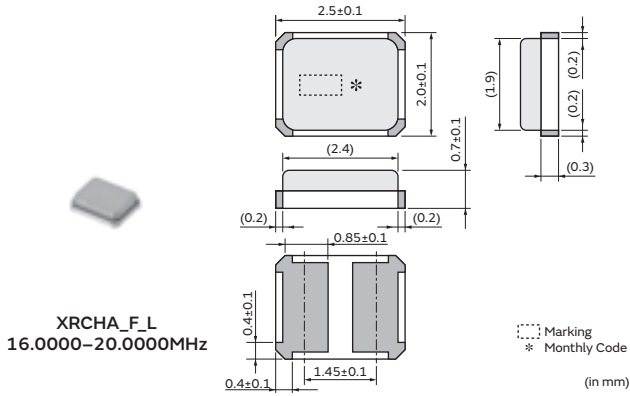
1



Series

Series	Type	Size	Package	Frequency (MHz)	Frequency Tolerance (ppm max.) [at 25°C±3°C]	Frequency Shift by Temperature (ppm max.) [Standard Condition: +25°C]	Frequency Aging (ppm max./Year)	Drive Level (μW max.)	Operating Temperature Range (°C)
XRCFD	-	1612	Metal	24.0000 to 31.9999	±10	±10	±1	100	-20 to +70
XRCMD				32.0000 to 48.0000					
XRCGB_F_P		2016	Resin	24.0000 to 32.0000	±20	±20	±5	300	
XRCPB_F_P				24.0000 to 48.0000					
XRCGB_F_M				±30/±45	±40				
XRCPB_F_M						±100			
XRCGB_F_L		±100	±50						
XRCPB_F_L				±100	±50				
XRCCHA_F_L	16.0000 to 20.0000	±100	±100			60	-30 to +85		
XRCHJ	16.0000 to 52.0000	±10	±15						
XRCJK	TSS-3225J	3225	Seam	12.0000 to 52.0000	±10	±15	±3	60	-30 to +85
XRCLK	TSS-5032A	5032	Seam	10.0000 to 52.0000	±10	±15	±3	60	-30 to +85

XRCPB series is a low profile type of XRCGB series.

Part Number List

Series	Type	Part Number	Frequency (MHz)	Frequency Tolerance (ppm max.) [at 25°C±3°C]	Frequency Shift by Temperature (ppm max.) [Standard Condition: +25°C]	Frequency Aging (ppm max./Year)	ESR* (Ωmax.)	Load Capacitance (pF)	Drive Level (μW max.)
XRCMD	-	XRCMD37M400F1Q01R0	37.4000	±10	±10 (-20 to +70°C)	±1	60	8	100
XRCGB_F_P	-	XRCGB24M000F2P00R0	24.0000	±20	±20 (-30 to +85°C)	±5	150	6	300
XRCGB_F_P	-	XRCGB25M000F2P00R0	25.0000	±20	±20 (-30 to +85°C)	±5	150	6	300
XRCGB_F_P	-	XRCGB26M000F2P00R0	26.0000	±20	±20 (-30 to +85°C)	±5	150	6	300
XRCGB_F_P	-	XRCGB27M000F2P00R0	27.0000	±20	±20 (-30 to +85°C)	±5	150	6	300
XRCGB_F_P	-	XRCGB27M120F2P00R0	27.1200	±20	±20 (-30 to +85°C)	±5	150	6	300
XRCGB_F_P	-	XRCGB27M120F2P10R0	27.1200	±20	±20 (-30 to +85°C)	±5	80	10	300
XRCGB_F_P	-	XRCGB30M000F2P00R0	30.0000	±20	±20 (-30 to +85°C)	±5	100	6	300
XRCGB_F_P	-	XRCGB31M250F2P00R0	31.2500	±20	±20 (-30 to +85°C)	±5	100	6	300
XRCGB_F_P	-	XRCGB32M000F2P00R0	32.0000	±20	±20 (-30 to +85°C)	±5	100	6	300
XRCPB_F_P	-	XRCPB24M000F2P00R0	24.0000	±20	±20 (-30 to +85°C)	±5	150	6	300

* Equivalent Series Resistance

Continued on the following page. ↗

6

Continued from the preceding page. ↘

Series	Type	Part Number	Frequency (MHz)	Frequency Tolerance (ppm max.) [at 25°C±3°C]	Frequency Shift by Temperature (ppm max.) [Standard Condition: +25°C]	Frequency Aging (ppm max./Year)	ESR* (Ωmax.)	Load Capacitance (pF)	Drive Level (μW max.)
XRCPB_F_P	-	XRCPB25M000F2P00R0	25.0000	±20	±20 (-30 to +85°C)	±5	150	6	300
XRCPB_F_P	-	XRCPB26M000F2P00R0	26.0000	±20	±20 (-30 to +85°C)	±5	150	6	300
XRCPB_F_P	-	XRCPB27M000F2P00R0	27.0000	±20	±20 (-30 to +85°C)	±5	150	6	300
XRCPB_F_P	-	XRCPB27M120F2P00R0	27.1200	±20	±20 (-30 to +85°C)	±5	150	6	300
XRCPB_F_P	-	XRCPB30M000F2P00R0	30.0000	±20	±20 (-30 to +85°C)	±5	100	6	300
XRCPB_F_P	-	XRCPB31M250F2P00R0	31.2500	±20	±20 (-30 to +85°C)	±5	100	6	300
XRCPB_F_P	-	XRCPB32M000F2P00R0	32.0000	±20	±20 (-30 to +85°C)	±5	100	6	300
XRCGB_F_M	-	XRCGB24M000F3M00R0	24.0000	±30	±40 (-30 to +85°C)	±5	150	6	300
XRCGB_F_M	-	XRCGB24M576F3M00R0	24.5760	±30	±40 (-30 to +85°C)	±5	150	6	300
XRCGB_F_M	-	XRCGB25M000F3M00R0	25.0000	±30	±40 (-30 to +85°C)	±5	150	6	300
XRCGB_F_M	-	XRCGB26M000F3M00R0	26.0000	±30	±40 (-30 to +85°C)	±5	150	6	300
XRCGB_F_M	-	XRCGB27M000F3M00R0	27.0000	±30	±40 (-30 to +85°C)	±5	150	6	300
XRCGB_F_M	-	XRCGB27M120F3M00R0	27.1200	±30	±40 (-30 to +85°C)	±5	150	6	300
XRCGB_F_M	-	XRCGB27M120F3M10R0	27.1200	±30	±40 (-30 to +85°C)	±5	80	10	300
XRCGB_F_M	-	XRCGB30M000F3M00R0	30.0000	±30	±40 (-30 to +85°C)	±5	100	6	300
XRCGB_F_M	-	XRCGB31M250F3M00R0	31.2500	±30	±40 (-30 to +85°C)	±5	100	6	300
XRCGB_F_M	-	XRCGB32M000F3M00R0	32.0000	±30	±40 (-30 to +85°C)	±5	100	6	300
XRCGB_F_M	-	XRCGB33M868F4M00R0	33.8688	±45	±40 (-30 to +85°C)	±5	100	6	300
XRCGB_F_M	-	XRCGB40M000F4M00R0	40.0000	±45	±40 (-30 to +85°C)	±5	100	6	300
XRCGB_F_M	-	XRCGB48M000F4M00R0	48.0000	±45	±40 (-30 to +85°C)	±5	100	6	300
XRCPB_F_M	-	XRCPB24M000F3M00R0	24.0000	±30	±40 (-30 to +85°C)	±5	150	6	300
XRCPB_F_M	-	XRCPB24M576F3M00R0	24.5760	±30	±40 (-30 to +85°C)	±5	150	6	300
XRCPB_F_M	-	XRCPB25M000F3M00R0	25.0000	±30	±40 (-30 to +85°C)	±5	150	6	300
XRCPB_F_M	-	XRCPB26M000F3M00R0	26.0000	±30	±40 (-30 to +85°C)	±5	150	6	300
XRCPB_F_M	-	XRCPB27M000F3M00R0	27.0000	±30	±40 (-30 to +85°C)	±5	150	6	300
XRCPB_F_M	-	XRCPB27M120F3M00R0	27.1200	±30	±40 (-30 to +85°C)	±5	150	6	300
XRCPB_F_M	-	XRCPB30M000F3M00R0	30.0000	±30	±40 (-30 to +85°C)	±5	100	6	300
XRCPB_F_M	-	XRCPB31M250F3M00R0	31.2500	±30	±40 (-30 to +85°C)	±5	100	6	300
XRCPB_F_M	-	XRCPB32M000F3M00R0	32.0000	±30	±40 (-30 to +85°C)	±5	100	6	300
XRCPB_F_M	-	XRCPB33M868F4M00R0	33.8688	±45	±40 (-30 to +85°C)	±5	100	6	300
XRCPB_F_M	-	XRCPB40M000F4M00R0	40.0000	±45	±40 (-30 to +85°C)	±5	100	6	300
XRCPB_F_M	-	XRCPB48M000F4M00R0	48.0000	±45	±40 (-30 to +85°C)	±5	100	6	300
XRCGB_F_L	-	XRCGB24M000F0L00R0	24.0000	±100	±50 (-30 to +85°C)	±5	150	6	300
XRCGB_F_L	-	XRCGB24M576F0L00R0	24.5760	±100	±50 (-30 to +85°C)	±5	150	6	300
XRCGB_F_L	-	XRCGB25M000F0L00R0	25.0000	±100	±50 (-30 to +85°C)	±5	150	6	300
XRCGB_F_L	-	XRCGB26M000F0L00R0	26.0000	±100	±50 (-30 to +85°C)	±5	150	6	300
XRCGB_F_L	-	XRCGB27M000F0L00R0	27.0000	±100	±50 (-30 to +85°C)	±5	150	6	300
XRCGB_F_L	-	XRCGB27M120F0L00R0	27.1200	±100	±50 (-30 to +85°C)	±5	150	6	300
XRCGB_F_L	-	XRCGB30M000F0L00R0	30.0000	±100	±50 (-30 to +85°C)	±5	100	6	300
XRCGB_F_L	-	XRCGB31M250F0L00R0	31.2500	±100	±50 (-30 to +85°C)	±5	100	6	300
XRCGB_F_L	-	XRCGB32M000F0L00R0	32.0000	±100	±50 (-30 to +85°C)	±5	100	6	300
XRCGB_F_L	-	XRCGB33M868F0L00R0	33.8688	±100	±50 (-30 to +85°C)	±5	100	6	300
XRCGB_F_L	-	XRCGB40M000F0L00R0	40.0000	±100	±50 (-30 to +85°C)	±5	100	6	300
XRCGB_F_L	-	XRCGB48M000F0L00R0	48.0000	±100	±50 (-30 to +85°C)	±5	100	6	300
XRCPB_F_L	-	XRCPB24M000F0L00R0	24.0000	±100	±50 (-30 to +85°C)	±5	150	6	300
XRCPB_F_L	-	XRCPB24M576F0L00R0	24.5760	±100	±50 (-30 to +85°C)	±5	150	6	300
XRCPB_F_L	-	XRCPB25M000F0L00R0	25.0000	±100	±50 (-30 to +85°C)	±5	150	6	300
XRCPB_F_L	-	XRCPB26M000F0L00R0	26.0000	±100	±50 (-30 to +85°C)	±5	150	6	300
XRCPB_F_L	-	XRCPB27M000F0L00R0	27.0000	±100	±50 (-30 to +85°C)	±5	150	6	300
XRCPB_F_L	-	XRCPB27M120F0L00R0	27.1200	±100	±50 (-30 to +85°C)	±5	150	6	300
XRCPB_F_L	-	XRCPB30M000F0L00R0	30.0000	±100	±50 (-30 to +85°C)	±5	100	6	300
XRCPB_F_L	-	XRCPB31M250F0L00R0	31.2500	±100	±50 (-30 to +85°C)	±5	100	6	300
XRCPB_F_L	-	XRCPB32M000F0L00R0	32.0000	±100	±50 (-30 to +85°C)	±5	100	6	300
XRCPB_F_L	-	XRCPB33M868F0L00R0	33.8688	±100	±50 (-30 to +85°C)	±5	100	6	300
XRCPB_F_L	-	XRCPB40M000F0L00R0	40.0000	±100	±50 (-30 to +85°C)	±5	100	6	300
XRCPB_F_L	-	XRCPB48M000F0L00R0	48.0000	±100	±50 (-30 to +85°C)	±5	100	6	300

* Equivalent Series Resistance

Continued on the following page. ↗

Continued from the preceding page. ↘

Series	Type	Part Number	Frequency (MHz)	Frequency Tolerance (ppm max.) [at 25°C±3°C]	Frequency Shift by Temperature (ppm max.) [Standard Condition: +25°C]	Frequency Aging (ppm max./Year)	ESR* (Ωmax.)	Load Capacitance (pF)	Drive Level (μW max.)
XRCHA_F_L	-	XRCHA16M000F0L01R0	16.0000	±100	±100 (-30 to +85°C)	±5	100	8	300
XRCHA_F_L	-	XRCHA20M000F0L01R0	20.0000	±100	±100 (-30 to +85°C)	±5	80	8	300
XRCHJ	TDS-2520F	XRCHJ16M000F1QB1P0	16.0000	±10	±15 (-30 to +85°C)	±3	100	8	60
XRCHJ	TDS-2520F	XRCHJ19M200F1QA9P0	19.2000	±10	±15 (-30 to +85°C)	±3	100	8	60
XRCHJ	TDS-2520F	XRCHJ20M000F1QA7P0	20.0000	±10	±15 (-30 to +85°C)	±3	80	8	60
XRCHJ	TDS-2520F	XRCHJ26M000F1QD1P0	26.0000	±10	±15 (-30 to +85°C)	±3	80	8	60
XRCHJ	TDS-2520F	XRCHJ36M000F1QA0P0	36.0000	±10	±15 (-30 to +85°C)	±3	80	8	60
XRCHJ	TDS-2520F	XRCHJ40M000F1QB0P0	40.0000	±10	±15 (-30 to +85°C)	±3	80	8	60
XRCHJ	TDS-2520F	XRCHJ52M000F1QA0P0	52.0000	±10	±15 (-30 to +85°C)	±3	80	8	60
XRCJK	TSS-3225J	XRCJK12M000F1QB4P0	12.0000	±10	±15 (-30 to +85°C)	±3	100	8	60
XRCJK	TSS-3225J	XRCJK13M000F1QA3P0	13.0000	±10	±15 (-30 to +85°C)	±3	100	8	60
XRCJK	TSS-3225J	XRCJK15M360F1QA0P0	15.3600	±10	±15 (-30 to +85°C)	±3	80	8	60
XRCJK	TSS-3225J	XRCJK20M000F1QB3P0	20.0000	±10	±15 (-30 to +85°C)	±3	80	8	60
XRCJK	TSS-3225J	XRCJK24M576F1QA0P0	24.5760	±10	±15 (-30 to +85°C)	±3	80	8	60
XRCJK	TSS-3225J	XRCJK26M000F1QC3P0	26.0000	±10	±15 (-30 to +85°C)	±3	80	8	60
XRCJK	TSS-3225J	XRCJK36M000F1QA0P0	36.0000	±10	±15 (-30 to +85°C)	±3	80	8	60
XRCJK	TSS-3225J	XRCJK40M000F1QA2P0	40.0000	±10	±15 (-30 to +85°C)	±3	80	8	60
XRCJK	TSS-3225J	XRCJK52M000F1QA0P0	52.0000	±10	±15 (-30 to +85°C)	±3	80	8	60
XRCLK	TSS-5032A	XRCLK10M000F1QA8P0	10.0000	±10	±15 (-30 to +85°C)	±3	80	8	60
XRCLK	TSS-5032A	XRCLK12M000F1QA6P0	12.0000	±10	±15 (-30 to +85°C)	±3	60	8	60
XRCLK	TSS-5032A	XRCLK14M745F1QB6P0	14.7456	±10	±15 (-30 to +85°C)	±3	60	8	60
XRCLK	TSS-5032A	XRCLK16M000F1QA7P0	16.0000	±10	±15 (-30 to +85°C)	±3	60	8	60
XRCLK	TSS-5032A	XRCLK21M250F1QA8P0	21.2500	±10	±15 (-30 to +85°C)	±3	60	8	60
XRCLK	TSS-5032A	XRCLK52M000F1QA0P0	52.0000	±10	±15 (-30 to +85°C)	±3	60	8	60

* Equivalent Series Resistance

Standard Land Pattern Dimensions

XRCFD, XRCMD

(Recommended Land Pattern)

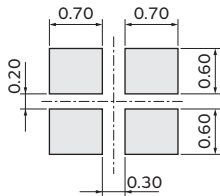

(in mm)

XRCGB_F_P/M/L, XRCPB_F_P/M/L

(Recommended Land Pattern)

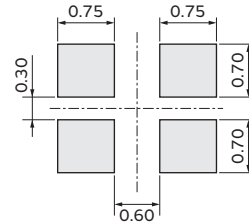

(in mm)

XRCHA_F_L

(Recommended Land Pattern)

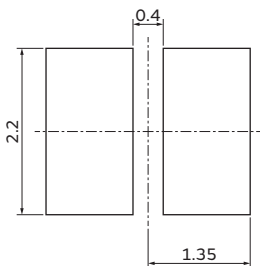

(in mm)

XRCHJ (TDS-2520F)

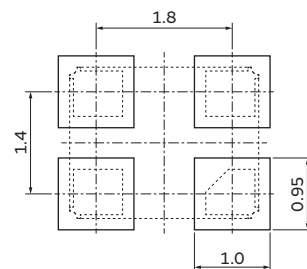

(in mm)

Continued from the preceding page. ↘

Standard Land Pattern Dimensions

XRCJK
(TSS-3225J)

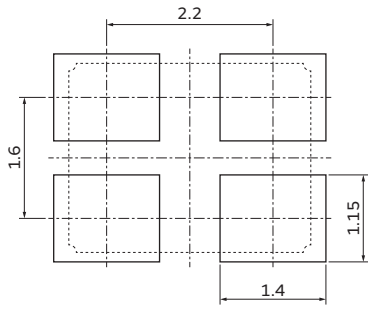

(in mm)

XRCLK
(TSS-5032A)

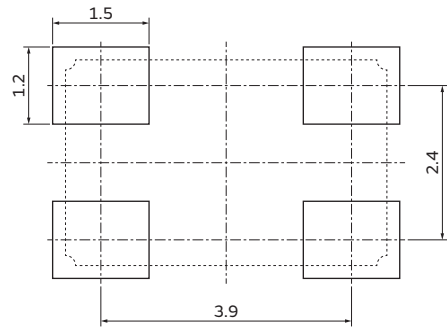

(in mm)

Notice -Crystal Units for Consumer-

1

Notice (Soldering and Mounting)

1.1. Soldering Condition

(1) Reflow

Please mount components on a circuit board by the reflow soldering method.

Flux: Please use rosin based flux; do not use water soluble flux.

Solder: Please use solder (Sn-3.0Ag-0.5Cu) under the following condition.

Standard thickness of soldering paste: 0.10 to 0.15mm

	Condition	
Pre-heating	150 to 180°C	60 to 120 sec.
Heating	220°C min.	30 to 60 sec.
Peak Temperature	245°C min. 260°C max. 5 sec. max.	

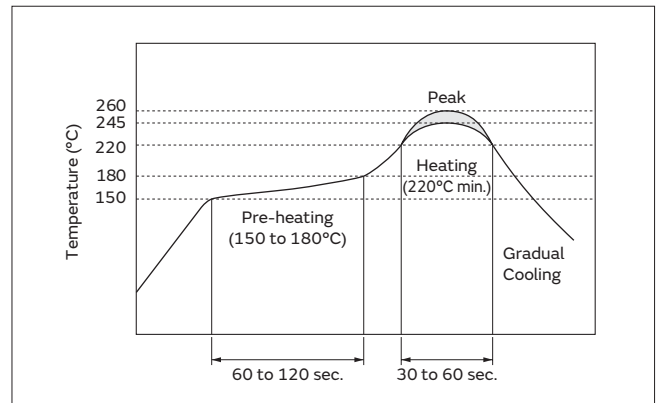

(2) Soldering Iron

If compelled to mount the component by using a soldering iron, please do not directly touch the component with the soldering iron. The component terminals or electrical characteristics may be damaged if excessive thermal stress is applied. Please keep solder away from the metal cap (Lid) portion.

	Condition
Pre-heating	150°C 60 sec.
Heating of the Soldering Iron	350°C max.
Watt	30W max.
Shape of the Soldering Iron	ø3mm max.
Soldering Time	5 sec. max.
Solder	Sn-3.0Ag-0.5Cu

1.2. Optimum Solder Amount for Soldering

Please make the solder volume below the height of the substrate. When exceeding the substrate, the damage to the sealing between the metal cap and the substrate may occur.

2. Wash

The component cannot withstand washing.

3. Notice for Mounting

The component is recommended for placement machines employing optical placement capabilities. The component might be damaged by mechanical force depending on placement machine and condition. Make sure that you have evaluated by using placement machines before going into mass production. Do not use placement machines employing mechanical positioning. Please contact Murata for details beforehand.

Continued on the following page. ↗

Notice -Crystal Units for Consumer-

Continued from the preceding page. ↘

Notice (Storage and Operating Condition)

1. Product Storage Condition

Please store the products in a room where the temperature/humidity is stable and avoid places where there are large temperature changes. Please store the products under the following conditions:

Temperature: -10 to + 40 degrees C

Humidity: 15 to 85% R.H.

2. Expire Date on Storage

Expiration date (shelf life) of the products is six months after delivery under the conditions of a sealed and unopened package. Please use the products within six months after delivery. If you store the products for a long time (more than six months), use carefully because the products may be degraded in solderability and/or rusty. Please confirm solderability and characteristics for the products regularly.

3. Notice on Product Storage

(1) Please do not store the products in a chemical atmosphere (Acids, Alkali, Bases, Organic gas, Sulfides and so on), because the characteristics may be reduced in quality, and/or be degraded in solderability due to the storage in a chemical atmosphere.

(2) Please do not put the products directly on the floor without anything under them to avoid damp places and/or dusty places.

(3) Please do not store the products in places such as in a damp heated place or any place exposed to direct sunlight or excessive vibration.

(4) Please use the products immediately after the package is opened, because the characteristics may be reduced in quality, and/or be degraded in solderability due to storage under poor conditions.

(5) Please do not drop the products to avoid cracking the crystal element.

4. Other

Conformal coating or washing of the component is not acceptable.

Please be sure to consult with our sales representative or engineer prior to using the products.

Notice (Rating)

The component may be damaged if excess mechanical stress is applied.

Notice (Handling)

1. Irregular or stopped oscillation may occur under unmatched circuit conditions.

Please design your oscillation circuit to get 5 times or more of a negative resistance against the maximum value of the Equivalent Series Resistance, that is specified in order.

2. Be sure to provide an appropriate fail-safe function on your product to prevent secondary damage that may be caused by the abnormal function or the failure of our product.

3. Please do not use these products in the following applications in transportation equipment: vehicles, trains, ships, etc.

(example: engine control, brake control, steering control, body control.)

Packaging -Crystal Units for Consumer-

1

Minimum Quantity/Dimensions of Reel

Plastic Tape $\phi 180\text{mm}$	Plastic Tape $\phi 330\text{mm}$
3,000	9,000

(pcs.)

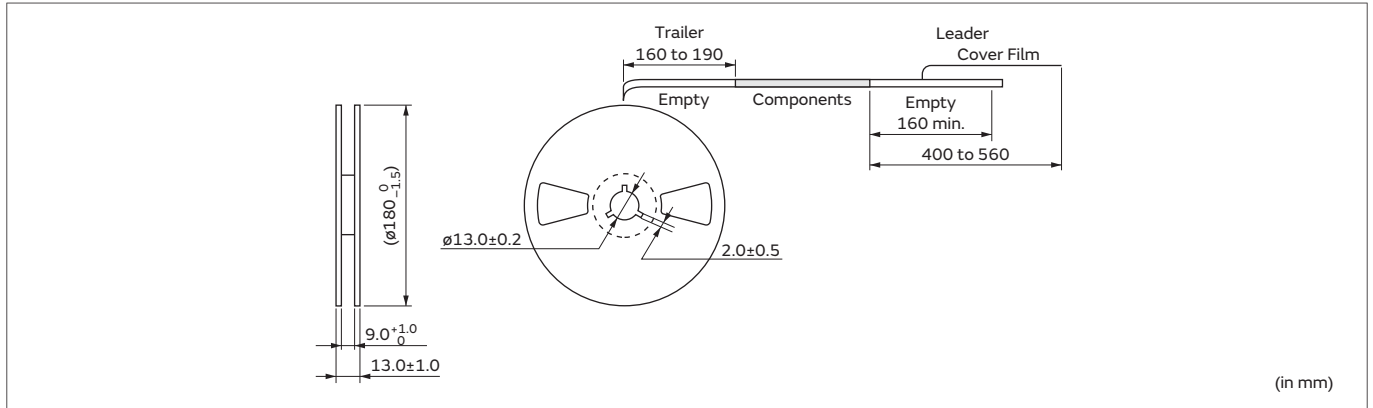

Dimensions of Taping

XRCFD, XRCMD

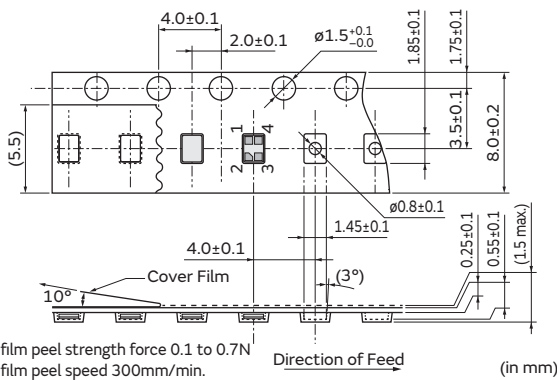

XRCGB_F_P/M/L

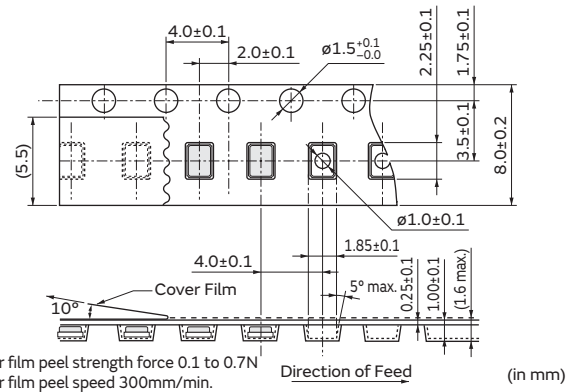

XRCPB_F_P/M/L

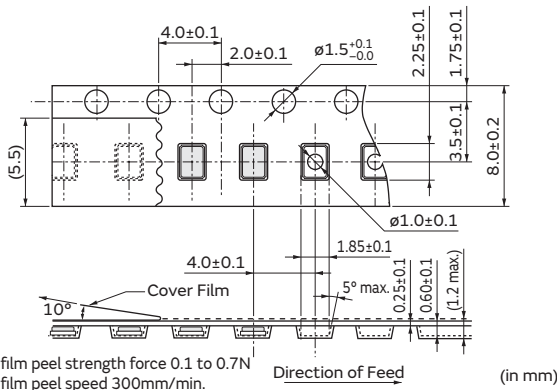

XRCHA_F_L

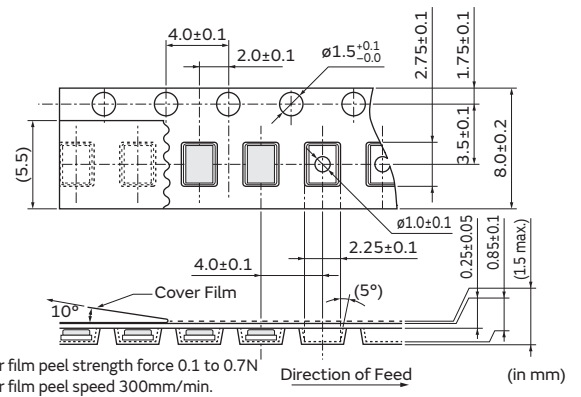

Packaging -Crystal Units for Consumer-

1

Minimum Quantity/Dimensions of Reel

Plastic Tape $\phi 180\text{mm}$

3,000

(pcs.)

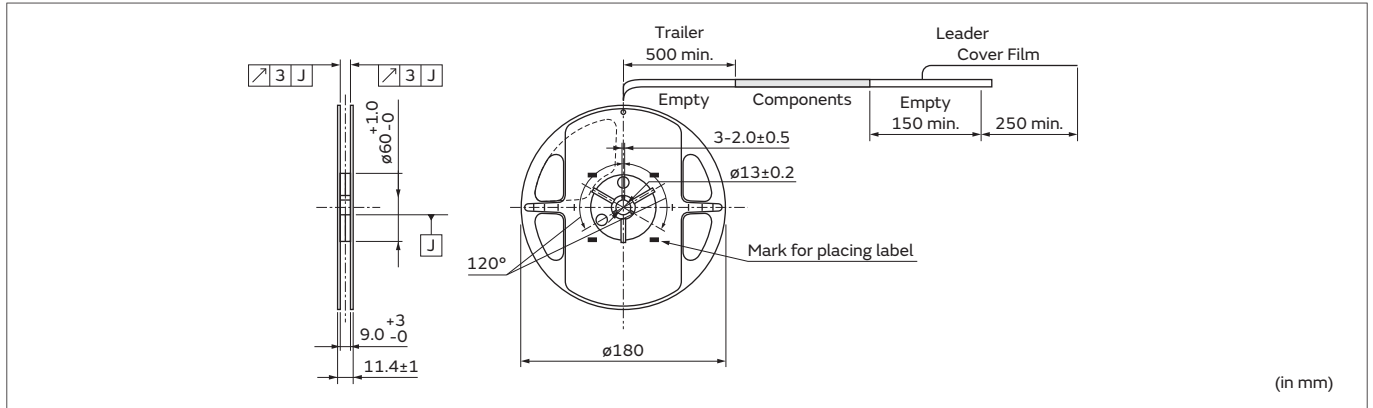

Dimensions of Taping

XRCHJ
(TDS-2520F)

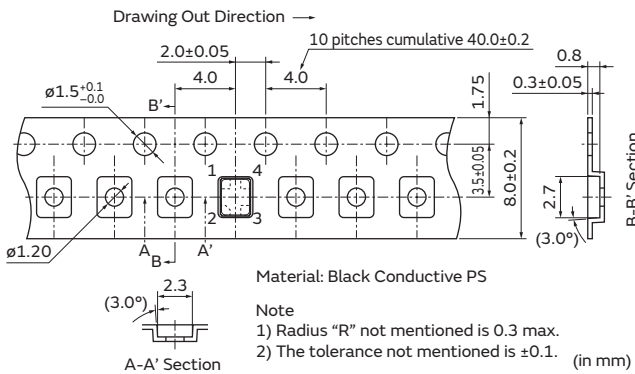

XRCJK
(TSS-3225J)

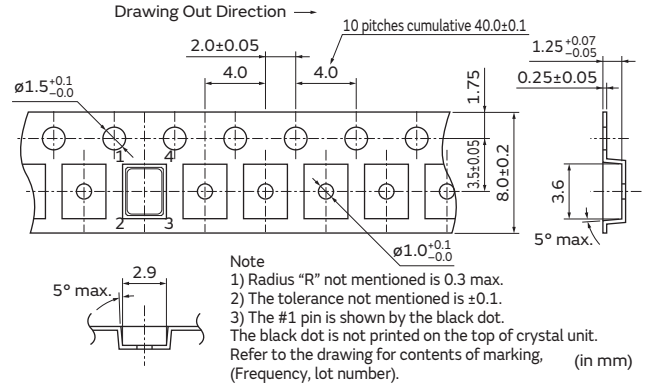

Packaging -Crystal Units for Consumer-

1

Minimum Quantity/Dimensions of Reel

Plastic Tape $\varnothing 255\text{mm}$

3,000

(pcs.)

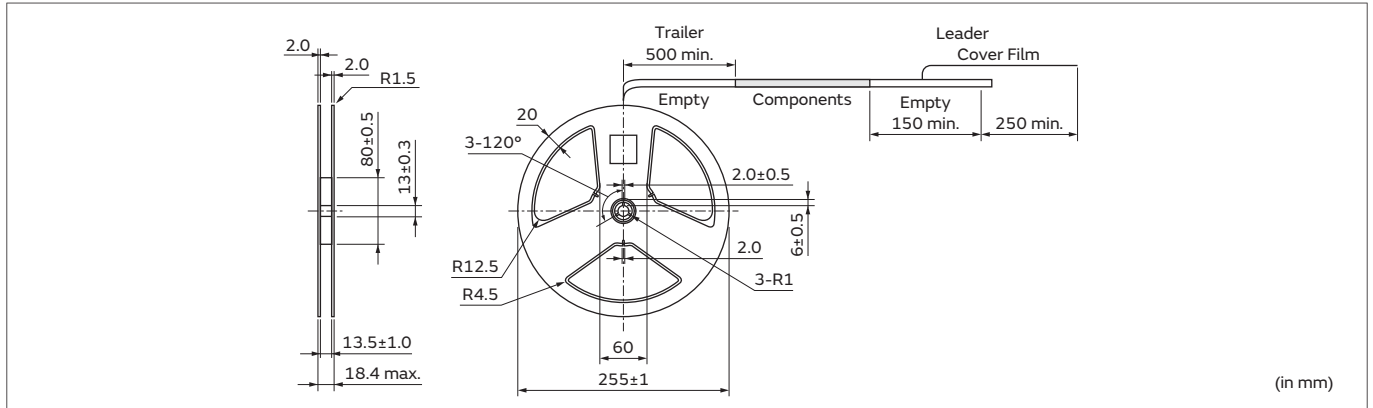

Dimensions of Taping

XRCLK
 (TSS-5032A)

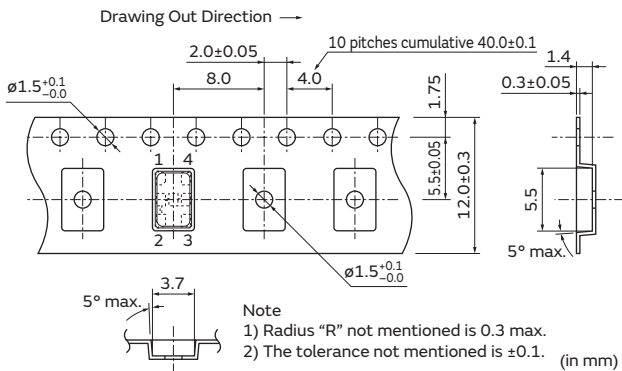

Crystal Units

for Automotive



These crystal units for automotive feature a small package and highly accurate frequency, based on Murata's excellent package technology and high grade quartz crystal elements.

Features

1. The series has high reliability and is available for a wide temperature range.
2. The crystal units are extremely small, contributing to a reduction in the mounting area.
3. The series complies to RoHS and ELV directives, being lead-free (phase 3).
4. The series complies to AEC-Q200.

Applications

1. Power Train (ex. Engine/Transmission management ECU)
2. ADAS (ex. Camera for driver assist, Image processing, Emergency Brake Assist ECU)
3. Chassis, Safety applications, etc.
4. Car multimedia equipment.

XRCHA_F_A
 16.0000–24.0000MHz

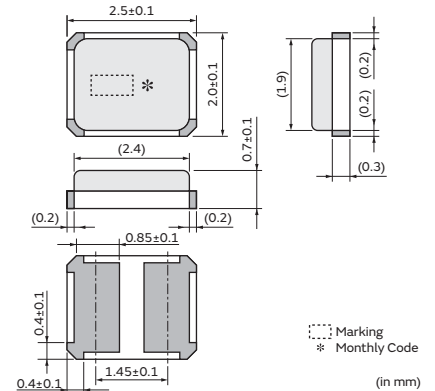

XRCGB_F_A
 24.0000–48.0000MHz

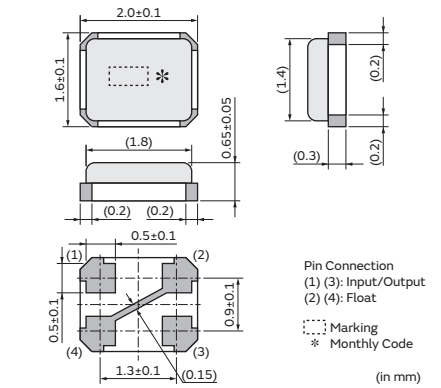

XRCGB_F_G
 24.0000–48.0000MHz

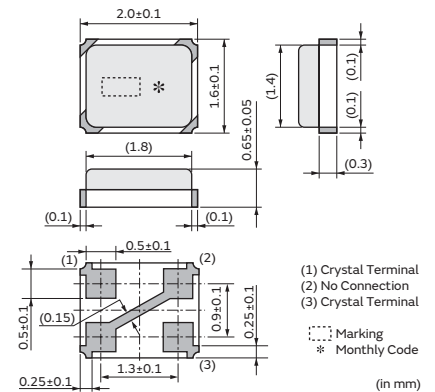

Series

Series	Size	Package	Frequency (MHz)	Frequency Tolerance (ppm max.) [at 25°C±3°C]	Frequency Shift by Temperature (ppm max.) [Standard Condition: +25°C]	Frequency Aging (ppm max./Year)	Operating Temperature Range (°C)	Applications
XRCHA_F_A	2520	Resin	16.0000 to 24.0000	±100	±100	±5	-40 to +125*	ADAS, Power Train, Chassis, Safety
XRCGB_F_A	2016		24.0000 to 48.0000	±30/±50	±35/±65	±2	-40 to +125	ADAS, Power Train, Chassis, Safety
XRCGB_F_G			±30/±45/±100	±50	±5	-40 to +85	Car Multimedia	

* +150°C is available.

Part Number List

Series	Part Number	Frequency (MHz)	Frequency Tolerance (ppm max.) [at 25°C±3°C]	Frequency Shift by Temperature (ppm max.) [Standard Condition: +25°C]	Frequency Aging (ppm max./Year)	ESR* (Ωmax.)	Load Capacitance (pF)	Drive Level (μW max.)
XRCHA_F_A	XRCHA16M000FOA01R0	16.0000	±100	±100 (-40 to +125°C)	±5	100	8	300
XRCHA_F_A	XRCHA16M000FOA11R0	16.0000	±100	±100 (-40 to +125°C)	±5	100	8	600
XRCHA_F_A	XRCHA16M000FOA12R0	16.0000	±100	±100 (-40 to +150°C)	±5	100	8	300
XRCHA_F_A	XRCHA16M000FOA13R0	16.0000	±100	±100 (-40 to +150°C)	±5	100	8	600
XRCHA_F_A	XRCHA20M000FOA01R0	20.0000	±100	±100 (-40 to +125°C)	±5	80	8	300
XRCHA_F_A	XRCHA20M000FOA11R0	20.0000	±100	±100 (-40 to +125°C)	±5	80	8	600
XRCHA_F_A	XRCHA20M000FOA12R0	20.0000	±100	±100 (-40 to +150°C)	±5	80	8	300
XRCHA_F_A	XRCHA20M000FOA13R0	20.0000	±100	±100 (-40 to +150°C)	±5	80	8	600
XRCHA_F_A	XRCHA24M000FOA01R0	24.0000	±100	±100 (-40 to +125°C)	±5	80	8	300
XRCHA_F_A	XRCHA24M000FOA11R0	24.0000	±100	±100 (-40 to +125°C)	±5	80	8	600
XRCHA_F_A	XRCHA24M000FOA12R0	24.0000	±100	±100 (-40 to +150°C)	±5	80	8	300
XRCHA_F_A	XRCHA24M000FOA13R0	24.0000	±100	±100 (-40 to +150°C)	±5	80	8	600
XRCGB_F_A	XRCGB24M000F3A00R0	24.0000	±30	±35 (-40 to +125°C)	±2	120	6	300
XRCGB_F_A	XRCGB25M000F3A00R0	25.0000	±30	±35 (-40 to +125°C)	±2	100	6	300
XRCGB_F_A	XRCGB26M000F3A00R0	26.0000	±30	±35 (-40 to +125°C)	±2	80	6	300
XRCGB_F_A	XRCGB27M000F3A00R0	27.0000	±30	±35 (-40 to +125°C)	±2	80	6	300
XRCGB_F_A	XRCGB27M120F3A00R0	27.1200	±30	±35 (-40 to +125°C)	±2	80	6	300
XRCGB_F_A	XRCGB48M000F5A00R0	48.0000	±50	±65 (-40 to +125°C)	±2	60	6	300
XRCGB_F_G	XRCGB24M000F0G00R0	24.0000	±100	±50 (-40 to +85°C)	±5	150	6	300
XRCGB_F_G	XRCGB24M000F3G00R0	24.0000	±30	±50 (-40 to +85°C)	±5	150	6	300
XRCGB_F_G	XRCGB24M576F0G00R0	24.5760	±100	±50 (-40 to +85°C)	±5	150	6	300
XRCGB_F_G	XRCGB24M576F3G00R0	24.5760	±30	±50 (-40 to +85°C)	±5	150	6	300
XRCGB_F_G	XRCGB25M000F0G00R0	25.0000	±100	±50 (-40 to +85°C)	±5	150	6	300
XRCGB_F_G	XRCGB25M000F3G00R0	25.0000	±30	±50 (-40 to +85°C)	±5	150	6	300
XRCGB_F_G	XRCGB26M000F0G00R0	26.0000	±100	±50 (-40 to +85°C)	±5	150	6	300
XRCGB_F_G	XRCGB26M000F3G00R0	26.0000	±30	±50 (-40 to +85°C)	±5	150	6	300
XRCGB_F_G	XRCGB27M000F0G00R0	27.0000	±100	±50 (-40 to +85°C)	±5	150	6	300
XRCGB_F_G	XRCGB27M000F3G00R0	27.0000	±30	±50 (-40 to +85°C)	±5	150	6	300
XRCGB_F_G	XRCGB27M120F3G00R0	27.1200	±30	±50 (-40 to +85°C)	±5	150	6	300
XRCGB_F_G	XRCGB30M000F0G00R0	30.0000	±100	±50 (-40 to +85°C)	±5	100	6	300
XRCGB_F_G	XRCGB30M000F3G00R0	30.0000	±30	±50 (-40 to +85°C)	±5	100	6	300
XRCGB_F_G	XRCGB33M868F0G00R0	33.8688	±100	±50 (-40 to +85°C)	±5	100	6	300
XRCGB_F_G	XRCGB33M868F4G00R0	33.8688	±45	±50 (-40 to +85°C)	±5	100	6	300
XRCGB_F_G	XRCGB40M000F0G00R0	40.0000	±100	±50 (-40 to +85°C)	±5	100	6	300
XRCGB_F_G	XRCGB40M000F4G00R0	40.0000	±45	±50 (-40 to +85°C)	±5	100	6	300
XRCGB_F_G	XRCGB48M000F0G00R0	48.0000	±100	±50 (-40 to +85°C)	±5	100	6	300
XRCGB_F_G	XRCGB48M000F4G00R0	48.0000	±45	±50 (-40 to +85°C)	±5	100	6	300

* Equivalent Series Resistance

Standard Land Pattern Dimensions

XRCHA_F_A

(Recommended Land Pattern)

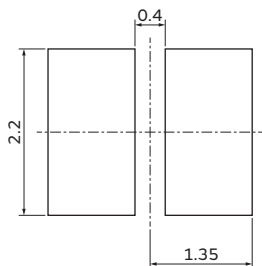

(in mm)

XRCGB_F_A/G

(Recommended Land Pattern)

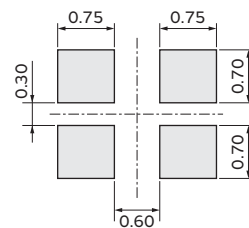

(in mm)

Notice -Crystal Units for Automotive-

Notice (Soldering and Mounting)

1.1. Soldering Condition

(1) Reflow

Please mount components on a circuit board by the reflow soldering method.

Flux: Please use rosin based flux; do not use water soluble flux.

Solder: Please use solder (Sn-3.0Ag-0.5Cu) under the following condition.

Standard thickness of soldering paste: 0.10 to 0.15mm

	Condition	
Pre-heating	150 to 180°C	60 to 120 sec.
Heating	220°C min.	30 to 60 sec.
Peak Temperature	245°C min. 260°C max. 5 sec. max.	

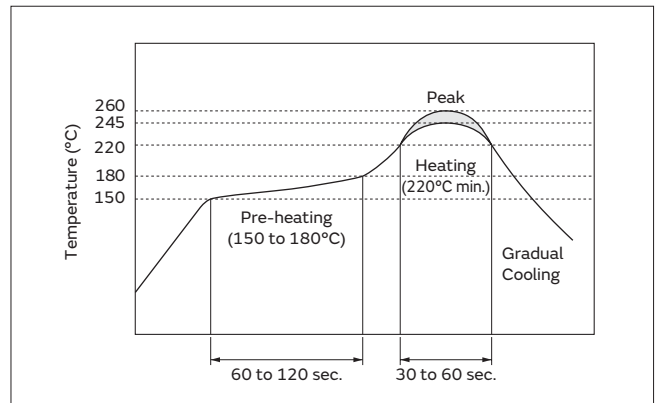

(2) Soldering Iron

If compelled to mount the component by using a soldering iron, please do not directly touch the component with the soldering iron. The component terminals or electrical characteristics may be damaged if excessive thermal stress is applied.

	Condition
Pre-heating	150°C 60 sec.
Heating of the Soldering Iron	350°C max.
Watt	30W max.
Shape of the Soldering Iron	ø3mm max.
Soldering Time	5 sec. max.
Solder	Sn-3.0Ag-0.5Cu

1.2. Optimum Solder Amount for Soldering

Please make the solder volume below the height of the substrate. When exceeding the substrate, damage to the sealing part between the metal cap and the substrate may occur.

1.3. Other

Do not reuse components once mounted onto a circuit board.

2. Wash

The component cannot withstand washing.

3. Notice for Mounting

The component is recommended for placement machines employing optical placement capabilities. The component might be damaged by mechanical force depending on placement machine and condition. Make sure that you have evaluated by using placement machines before going into mass production. Do not use placement machines employing mechanical positioning. Please contact Murata for details beforehand.

Continued on the following page. ↗

Notice -Crystal Units for Automotive-

Continued from the preceding page. ↘

Notice (Storage and Operating Condition)

1. Product Storage Condition

Please store the products in a room where the temperature/humidity is stable and avoid places where there are large temperature changes. Please store the products under the following conditions:

Temperature: -10 to + 40 degrees C

Humidity: 15 to 85% R.H.

2. Expire Date on Storage

Expiration date (shelf life) of the products is six months after delivery under the conditions of a sealed and unopened package. Please use the products within six months after delivery. If you store the products for a long time (more than six months), use carefully because the products may be degraded in solderability and/or rusty.

Please confirm solderability and characteristics for the products regularly.

3. Notice on Product Storage

- (1) Please do not store the products in a chemical atmosphere (Acids, Alkali, Bases, Organic gas, Sulfides and so on), because the characteristics may be reduced in quality, and/or be degraded in solderability due to the storage in a chemical atmosphere.

- (2) Please do not put the products directly on the floor without anything under them to avoid damp places and/or dusty places.

- (3) Please do not store the products in places such as in a damp heated place or any place exposed to direct sunlight or excessive vibration.

- (4) Please use the products immediately after the package is opened, because the characteristics may be reduced in quality, and/or be degraded in solderability due to storage under poor conditions.

- (5) Please do not drop the products to avoid cracking the crystal element.

4. Other

Conformal coating or washing of the component is not acceptable because it is not hermetically sealed.

Please be sure to consult with our sales representative or engineer whenever and prior to using the products.

Notice (Rating)

The component may be damaged if excess mechanical stress is applied.

Notice (Handling)

1. Irregular or stopped oscillation may occur under unmatched circuit conditions.

Please design your oscillation circuit to get 5 times or more of a negative resistance against the maximum value of the Equivalent Series Resistance, that is specified in order.

2. Be sure to provide an appropriate fail-safe function on your product to prevent secondary damage that may be caused by the abnormal function or the failure of our product.

Packaging -Crystal Units for Automotive-

Minimum Quantity/Dimensions of Reel

Plastic Tape $\phi 180\text{mm}$	Plastic Tape $\phi 330\text{mm}$
3,000	9,000

(pcs.)

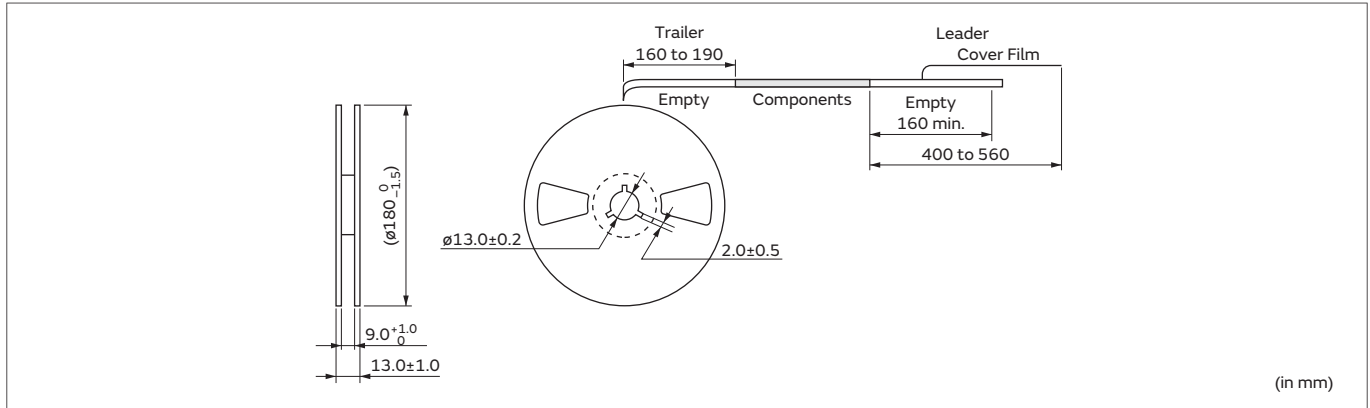

Dimensions of Taping

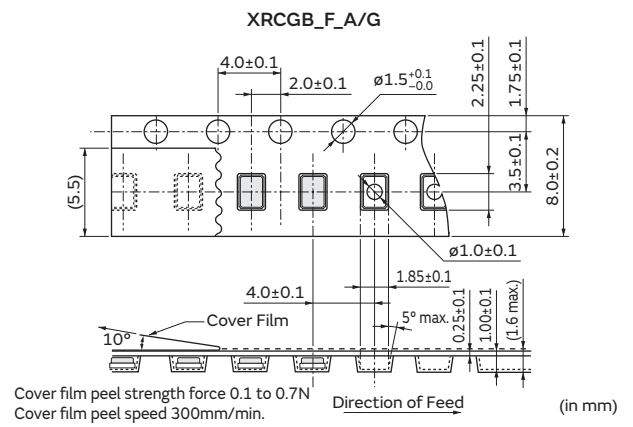
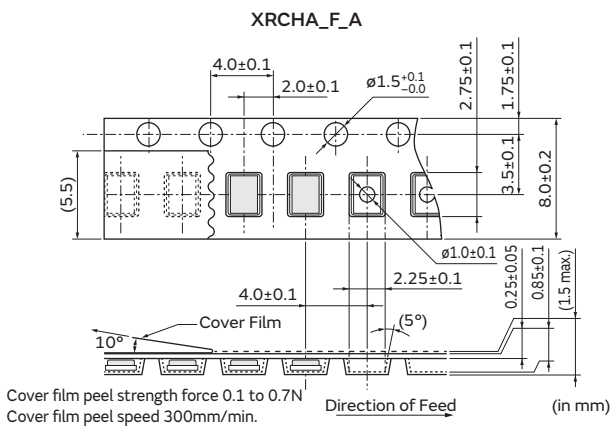

Crystal Units

for Industrial



These crystal units feature a small package and highly accurate frequency. Based on Murata's excellent package technology and high grade quartz crystal elements, achieving small size and high accuracy crystal units.

Features

1. The series is available in the applications to be necessary for high accuracy crystal units.
2. The crystal units are extremely small, contributing to a reduction in the mounting area.
3. The series complies to RoHS directive, being lead-free (phase 3).

Applications

1. Clock for PLC, Inverter, Servo Amp, Servo Motor, etc. controller ICs
2. Clock for LCD, Programmable display and Visual equipment controller ICs
3. Storage devices with SATA interface (Server, HDD, SSD, Optical storage device, etc.)
4. Clock for USB (Ultra-Speed and High-speed) controller ICs (Mobile phone, DVC, DSC, Portable audio, PC peripheral, etc.)
5. Other applications for replacement of other crystal units or oscillators

XRCGB_F_Z
 24.0000-48.0000MHz

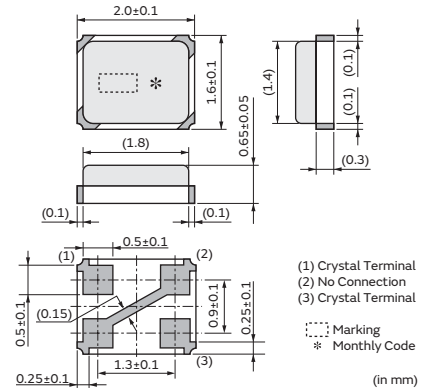

XRCPB_F_Z
 24.0000-48.0000MHz

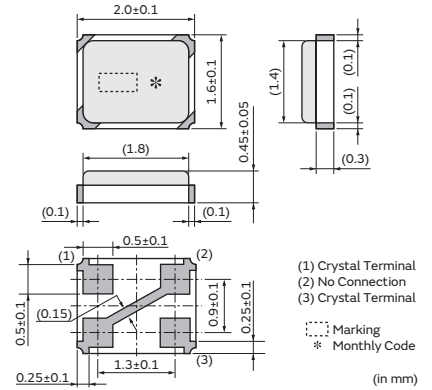

XRCHA_F_Z
 16.0000-20.0000MHz

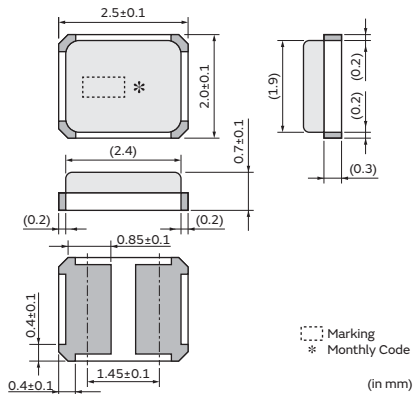

XRCHH
 (TAS-2520F)
 16.0000-52.0000MHz

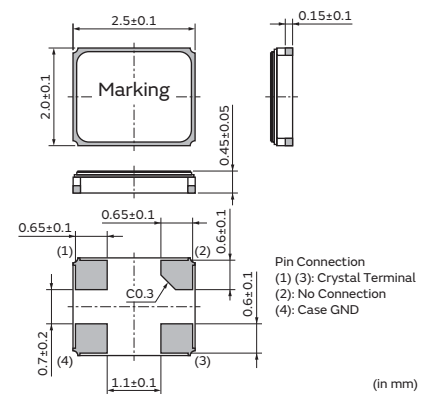

XRCJH
 (TAS-3225J)
 13.0000-52.0000MHz

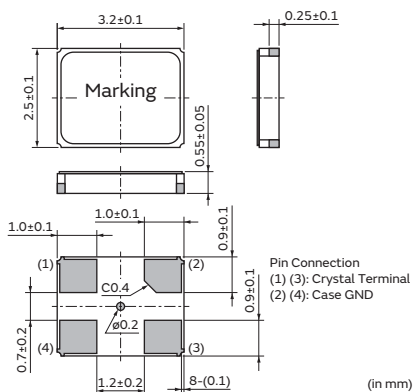

XRCLH
 (TAS-5032F)
 10.0000-52.0000MHz

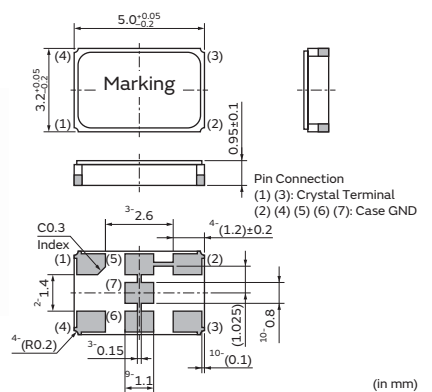

Series

Series	Type	Size	Package	Frequency (MHz)	Frequency Tolerance (ppm max.) [at 25°C±3°C]	Frequency Shift by Temperature (ppm max.) [Standard Condition: +25°C]	Frequency Aging (ppm max./Year)	Drive Level (µW max.)	Operating Temperature Range (°C)
XRCGB_F_Z	-	2016	Resin	24.0000 to 48.0000	±100	±100	±5	300	-40 to +105
XRCPB_F_Z				16.0000 to 20.0000					
XRCHA_F_Z		2520	16.0000 to 52.0000						
XRCHH	TAS-2520F	3225	Metal	13.0000 to 52.0000	±10	±15	±1(±3/5Years)	60	-30 to +85
XRCJH	TAS-3225J			10.0000 to 52.0000					
XRCLH	TAS-5032F			5032					

XRCPB series is a low profile type of XRCGB series.

Part Number List

Series	Type	Part Number	Frequency (MHz)	Frequency Tolerance (ppm max.) [at 25°C±3°C]	Frequency Shift by Temperature (ppm max.) [Standard Condition: +25°C]	Frequency Aging (ppm max./Year)	ESR* (Ωmax.)	Load Capacitance (pF)	Drive Level (µW max.)
XRCGB_F_Z	-	XRCGB24M000F0Z00R0	24.0000	±100	±100 (-40 to +105°C)	±5	150	6	300
XRCGB_F_Z	-	XRCGB24M576F0Z00R0	24.5760	±100	±100 (-40 to +105°C)	±5	150	6	300
XRCGB_F_Z	-	XRCGB25M000F0Z00R0	25.0000	±100	±100 (-40 to +105°C)	±5	150	6	300
XRCGB_F_Z	-	XRCGB26M000F0Z00R0	26.0000	±100	±100 (-40 to +105°C)	±5	150	6	300
XRCGB_F_Z	-	XRCGB27M000F0Z00R0	27.0000	±100	±100 (-40 to +105°C)	±5	150	6	300
XRCGB_F_Z	-	XRCGB27M120F0Z00R0	27.1200	±100	±100 (-40 to +105°C)	±5	150	6	300
XRCGB_F_Z	-	XRCGB30M000F0Z00R0	30.0000	±100	±100 (-40 to +105°C)	±5	100	6	300
XRCGB_F_Z	-	XRCGB31M250F0Z00R0	31.2500	±100	±100 (-40 to +105°C)	±5	100	6	300
XRCGB_F_Z	-	XRCGB32M000F0Z00R0	32.0000	±100	±100 (-40 to +105°C)	±5	100	6	300
XRCGB_F_Z	-	XRCGB33M868F0Z00R0	33.8688	±100	±100 (-40 to +105°C)	±5	100	6	300
XRCGB_F_Z	-	XRCGB40M000F0Z00R0	40.0000	±100	±100 (-40 to +105°C)	±5	100	6	300
XRCGB_F_Z	-	XRCGB48M000F0Z00R0	48.0000	±100	±100 (-40 to +105°C)	±5	100	6	300
XRCPB_F_Z	-	XRCPB24M000F0Z00R0	24.0000	±100	±100 (-40 to +105°C)	±5	150	6	300
XRCPB_F_Z	-	XRCPB24M576F0Z00R0	24.5760	±100	±100 (-40 to +105°C)	±5	150	6	300
XRCPB_F_Z	-	XRCPB25M000F0Z00R0	25.0000	±100	±100 (-40 to +105°C)	±5	150	6	300
XRCPB_F_Z	-	XRCPB26M000F0Z00R0	26.0000	±100	±100 (-40 to +105°C)	±5	150	6	300
XRCPB_F_Z	-	XRCPB27M000F0Z00R0	27.0000	±100	±100 (-40 to +105°C)	±5	150	6	300
XRCPB_F_Z	-	XRCPB27M120F0Z00R0	27.1200	±100	±100 (-40 to +105°C)	±5	150	6	300
XRCPB_F_Z	-	XRCPB30M000F0Z00R0	30.0000	±100	±100 (-40 to +105°C)	±5	100	6	300
XRCPB_F_Z	-	XRCPB31M250F0Z00R0	31.2500	±100	±100 (-40 to +105°C)	±5	100	6	300
XRCPB_F_Z	-	XRCPB32M000F0Z00R0	32.0000	±100	±100 (-40 to +105°C)	±5	100	6	300
XRCPB_F_Z	-	XRCPB33M868F0Z00R0	33.8688	±100	±100 (-40 to +105°C)	±5	100	6	300
XRCPB_F_Z	-	XRCPB40M000F0Z00R0	40.0000	±100	±100 (-40 to +105°C)	±5	100	6	300
XRCPB_F_Z	-	XRCPB48M000F0Z00R0	48.0000	±100	±100 (-40 to +105°C)	±5	100	6	300
XRCHA_F_Z	-	XRCHA16M000F0Z01R0	16.0000	±100	±100 (-40 to +105°C)	±5	100	8	300
XRCHA_F_Z	-	XRCHA20M000F0Z01R0	20.0000	±100	±100 (-40 to +105°C)	±5	80	8	300
XRCHH	TAS-2520F	XRCHH16M000F1QB7P0	16.0000	±10	±15 (-30 to +85°C)	±1 (±3/5Years)	80	8	60
XRCHH	TAS-2520F	XRCHH20M000F1QB1P0	20.0000	±10	±15 (-30 to +85°C)	±1 (±3/5Years)	60	8	60
XRCHH	TAS-2520F	XRCHH26M000F1QD8P0	26.0000	±10	±15 (-30 to +85°C)	±1 (±3/5Years)	60	8	60
XRCHH	TAS-2520F	XRCHH36M000F1QA3P0	36.0000	±10	±15 (-30 to +85°C)	±1 (±3/5Years)	60	8	60
XRCHH	TAS-2520F	XRCHH40M000F1QB3P0	40.0000	±10	±15 (-30 to +85°C)	±1 (±3/5Years)	60	8	60
XRCHH	TAS-2520F	XRCHH52M000F1QA2P0	52.0000	±10	±15 (-30 to +85°C)	±1 (±3/5Years)	60	8	60
XRCJH	TAS-3225J	XRCJH13M000F1QA0P0	13.0000	±10	±15 (-30 to +85°C)	±1 (±3/5Years)	80	8	60
XRCJH	TAS-3225J	XRCJH16M000F1QB5P0	16.0000	±10	±15 (-30 to +85°C)	±1 (±3/5Years)	80	8	60
XRCJH	TAS-3225J	XRCJH20M000F1QB3P0	20.0000	±10	±15 (-30 to +85°C)	±1 (±3/5Years)	60	8	60
XRCJH	TAS-3225J	XRCJH26M000F1QC1P0	26.0000	±10	±15 (-30 to +85°C)	±1 (±3/5Years)	60	8	60
XRCJH	TAS-3225J	XRCJH36M000F1QA1P0	36.0000	±10	±15 (-30 to +85°C)	±1 (±3/5Years)	60	8	60
XRCJH	TAS-3225J	XRCJH40M000F1QB2P0	40.0000	±10	±15 (-30 to +85°C)	±1 (±3/5Years)	60	8	60
XRCJH	TAS-3225J	XRCJH52M000F1QA1P0	52.0000	±10	±15 (-30 to +85°C)	±1 (±3/5Years)	60	8	60
XRCLH	TAS-5032F	XRCLH10M000F1QA4P0	10.0000	±10	±15 (-30 to +85°C)	±1 (±3/5Years)	60	8	60
XRCLH	TAS-5032F	XRCLH12M000F1QA0P0	12.0000	±10	±15 (-30 to +85°C)	±1 (±3/5Years)	60	8	60
XRCLH	TAS-5032F	XRCLH14M745F1QA0P0	14.7456	±10	±15 (-30 to +85°C)	±1 (±3/5Years)	40	8	60
XRCLH	TAS-5032F	XRCLH16M000F1QA2P0	16.0000	±10	±15 (-30 to +85°C)	±1 (±3/5Years)	40	8	60
XRCLH	TAS-5032F	XRCLH21M250F1QA0P0	21.2500	±10	±15 (-30 to +85°C)	±1 (±3/5Years)	40	8	60
XRCLH	TAS-5032F	XRCLH52M000F1QA1P0	52.0000	±10	±15 (-30 to +85°C)	±1 (±3/5Years)	40	8	60

* Equivalent Series Resistance

Standard Land Pattern Dimensions

XRCGB_F_Z, XRCPB_F_Z

(Recommended Land Pattern)

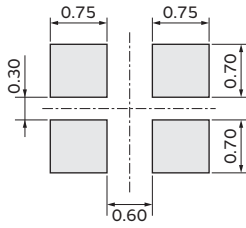

(in mm)

XRCHA_F_Z

(Recommended Land Pattern)

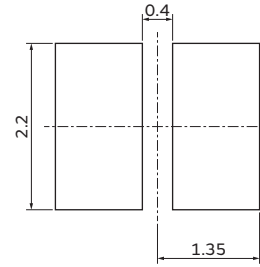

(in mm)

XRCHH
 (TAS-2520F)

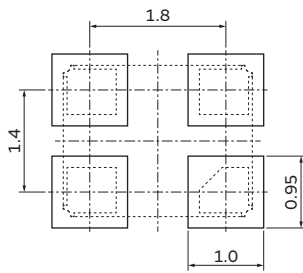

(in mm)

XRCJH
 (TAS-3225J)

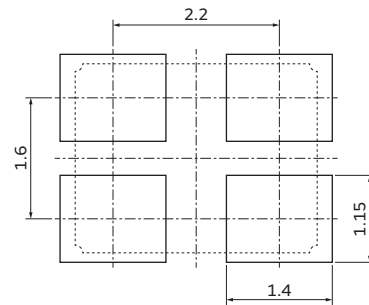

(in mm)

XRCLH
 (TAS-5032F)

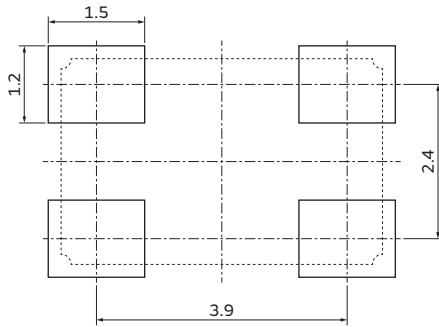

Avoid putting signal lines under the product except referenced land pattern.

(in mm)

Notice -Crystal Units for Industrial-

Notice (Soldering and Mounting)

1.1. Soldering Condition

(1) Reflow

Please mount components on a circuit board by the reflow soldering method.
 Flux: Please use rosin based flux; do not use water soluble flux.
 Solder: Please use solder (Sn-3.0Ag-0.5Cu) under the following condition.
 Standard thickness of soldering paste: 0.10 to 0.15mm

	Condition	
Pre-heating	150 to 180°C	60 to 120 sec.
Heating	220°C min.	30 to 60 sec.
Peak Temperature	245°C min. 260°C max. 5 sec. max.	

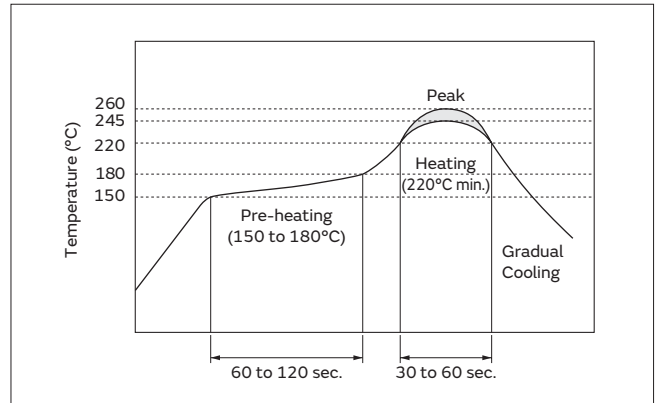

(2) Soldering Iron

If compelled to mount the component by using a soldering iron, please do not directly touch the component with the soldering iron. The component terminals or electrical characteristics may be damaged if excessive thermal stress is applied. Please keep solder away from the metal cap (Lid) portion.

	Condition
Pre-heating	150°C 60 sec.
Heating of the Soldering Iron	350°C max.
Watt	30W max.
Shape of the Soldering Iron	ø3mm max.
Soldering Time	5 sec. max.
Solder	Sn-3.0Ag-0.5Cu

1.2. Optimum Solder Amount for Soldering

Please make the solder volume below the height of the substrate. When exceeding the substrate, the damage to the sealing between the metal cap and the substrate may occur.

2. Wash

The component cannot withstand washing.

3. Notice for Mounting

The component is recommended for placement machines employing optical placement capabilities. The component might be damaged by mechanical force depending on placement machine and condition. Make sure that you have evaluated by using placement machines before going into mass production. Do not use placement machines employing mechanical positioning. Please contact Murata for details beforehand.

Continued on the following page. ↗

Notice -Crystal Units for Industrial-

Continued from the preceding page. ↘

Notice (Storage and Operating Condition)

1. Product Storage Condition

Please store the products in a room where the temperature/humidity is stable and avoid places where there are large temperature changes. Please store the products under the following conditions:

Temperature: -10 to + 40 degrees C

Humidity: 15 to 85% R.H.

2. Expire Date on Storage

Expiration date (shelf life) of the products is six months after delivery under the conditions of a sealed and unopened package. Please use the products within six months after delivery. If you store the products for a long time (more than six months), use carefully because the products may be degraded in solderability and/or rusty. Please confirm solderability and characteristics for the products regularly.

3. Notice on Product Storage

(1) Please do not store the products in a chemical atmosphere (Acids, Alkali, Bases, Organic gas, Sulfides and so on), because the characteristics may be reduced in quality, and/or be degraded in solderability due to the storage in a chemical atmosphere.

(2) Please do not put the products directly on the floor without anything under them to avoid damp places and/or dusty places.

(3) Please do not store the products in places such as in a damp heated place or any place exposed to direct sunlight or excessive vibration.

(4) Please use the products immediately after the package is opened, because the characteristics may be reduced in quality, and/or be degraded in solderability due to storage under poor conditions.

(5) Please do not drop the products to avoid cracking the crystal element.

4. Other

Conformal coating or washing of the component is not acceptable.

Please be sure to consult with our sales representative or engineer prior to using the products.

Notice (Rating)

The component may be damaged if excess mechanical stress is applied.

Notice (Handling)

1. Irregular or stopped oscillation may occur under unmatched circuit conditions.

Please design your oscillation circuit to get 5 times or more of a negative resistance against the maximum value of the Equivalent Series Resistance, that is specified in order.

2. Be sure to provide an appropriate fail-safe function on your product to prevent secondary damage that may be caused by the abnormal function or the failure of our product.

3. Please do not use these products in the following applications in transportation equipment: vehicles, trains, ships, etc.
(example: engine control, brake control, steering control, body control.)

Packaging -Crystal Units for Industrial-

Minimum Quantity/Dimensions of Reel

Plastic Tape $\phi 180\text{mm}$	Plastic Tape $\phi 330\text{mm}$
3,000	9,000

(pcs.)

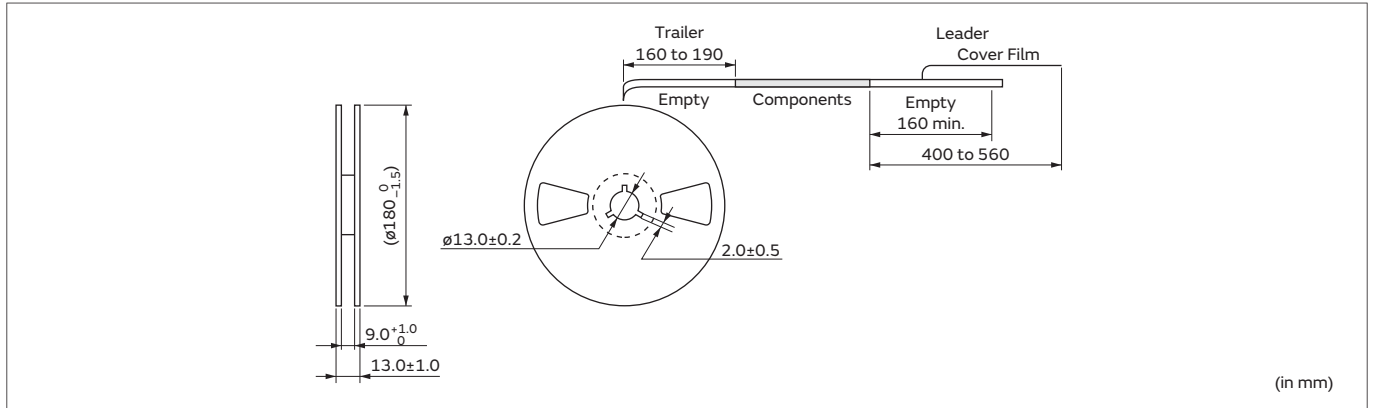

Dimensions of Taping

XRCGB_F_Z

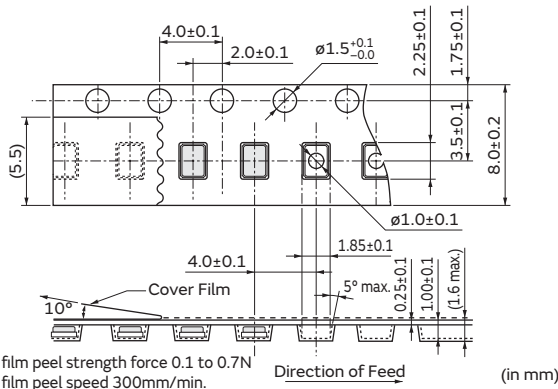

XRCPB_F_Z

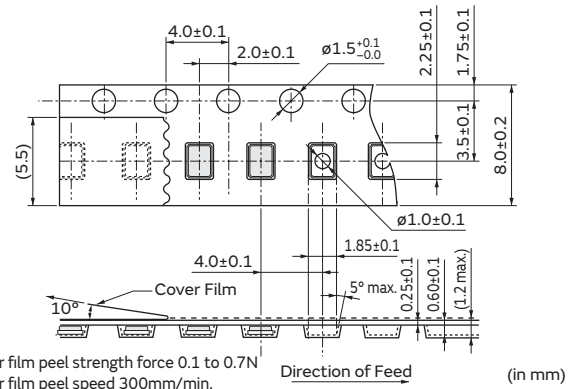

XRCHA_F_Z

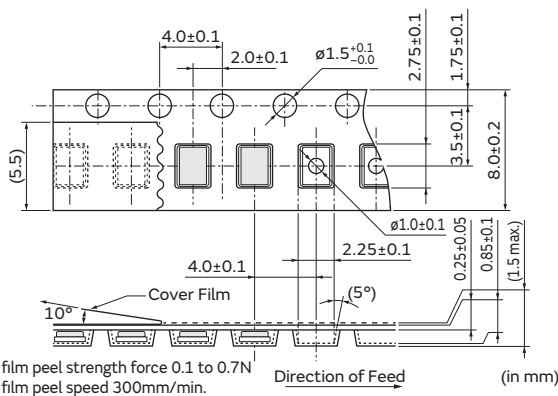

Packaging -Crystal Units for Industrial-

Minimum Quantity/Dimensions of Reel

Plastic Tape $\phi 180\text{mm}$

3,000

(pcs.)

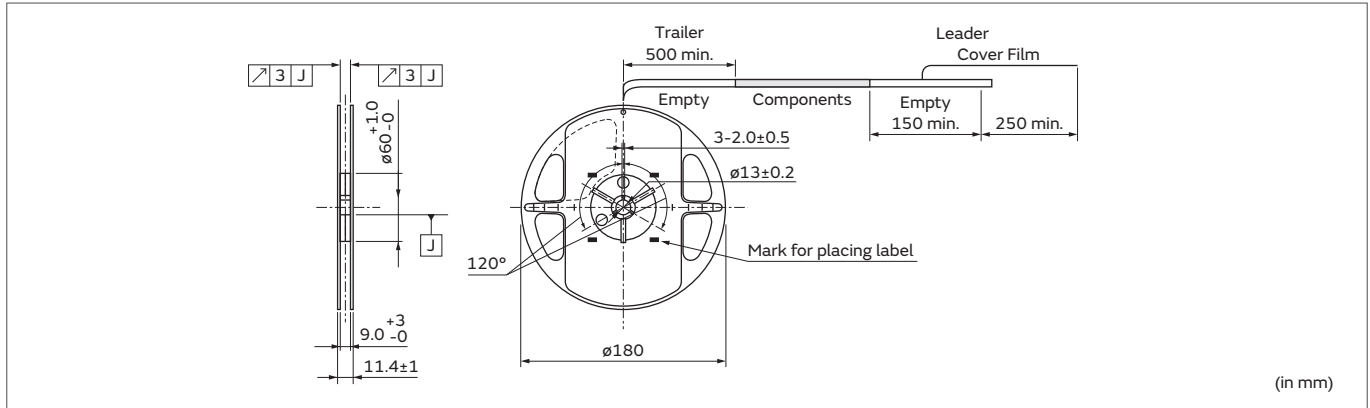

Dimensions of Taping

XRCHH
(TAS-2520F)

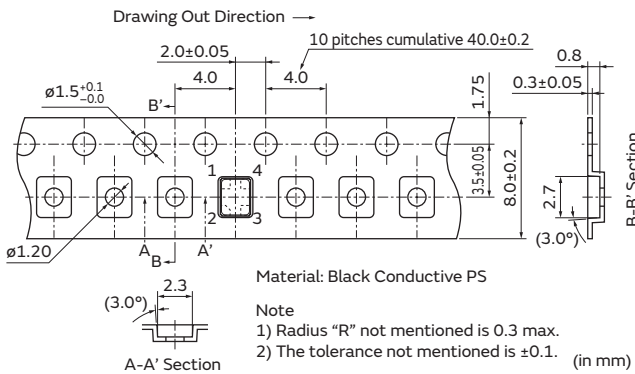

XRCJH
(TAS-3225J)

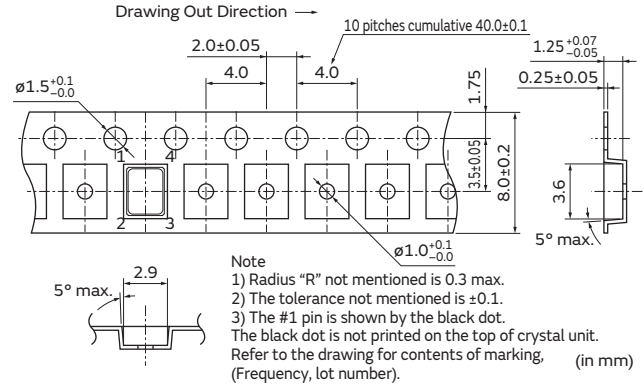

Packaging -Crystal Units for Industrial-

Minimum Quantity/Dimensions of Reel

Plastic Tape $\varnothing 255\text{mm}$

3,000

(pcs.)

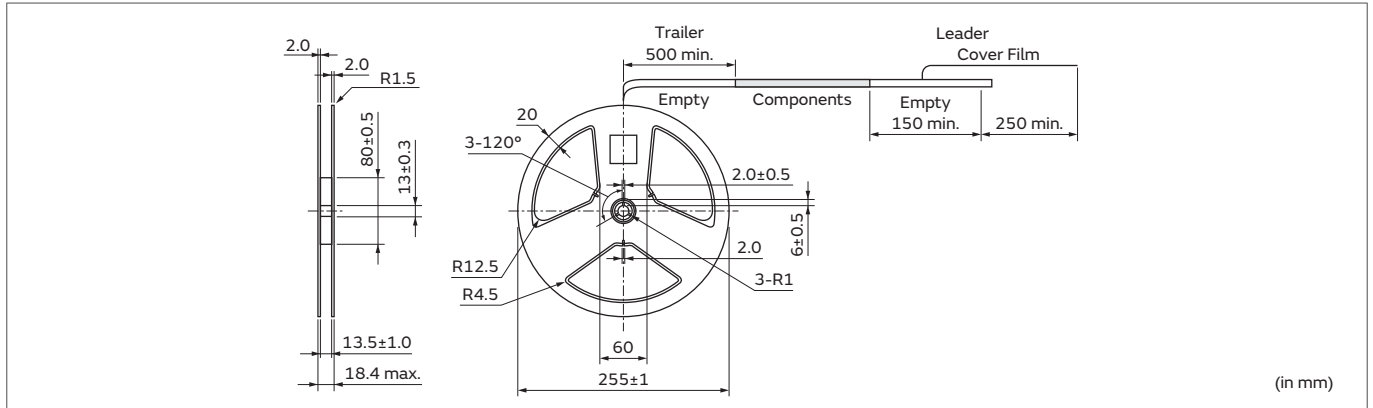

Dimensions of Taping

XRCLH
 (TAS-5032F)

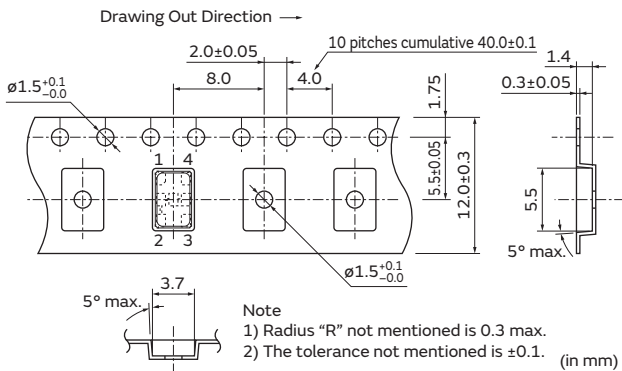

Crystal Oscillators

for Industrial



We offer a varied lineup of TCXO (Temperature compensated crystal oscillator)/VC-TCXO (Voltage-controlled temperature compensated crystal oscillator) based on highly reliable crystal units, superior temperature compensation and adjusting method fostered by our long experience and expertise.

Features

1. Excellent frequency stability over temperature
2. Low profile
3. Low supply voltage
4. SMD type (Reflow soldering available)
5. The series complies to RoHS directive, being lead-free (phase 3).

Applications

1. Business radios
2. GPS (GNSS) systems
3. Small cells
4. Wireless devices

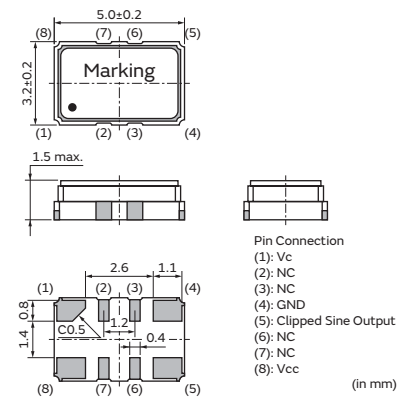
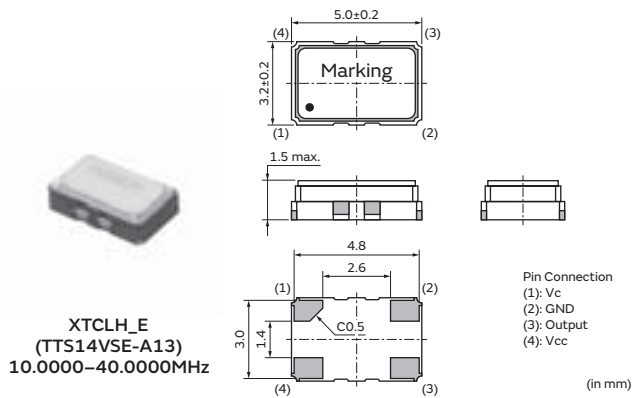
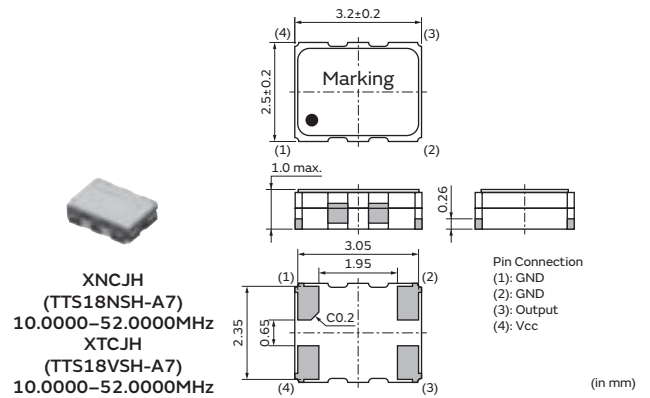
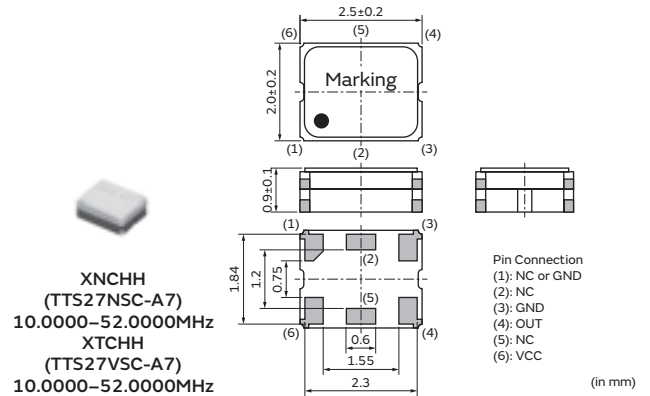

Series

Series	Type	Size	Package	Frequency (MHz)	Frequency Tolerance (ppm max.) [at 25°C±3°C]	Frequency Shift by Temperature (ppm max.) [Standard Condition: +25°C]	Frequency Aging (ppm max./Year)	Operating Temperature Range (°C)	Supply Voltage (Vp-p)	VC Function
XNCHH	TTS27NSC-A7	2520	Metal	10.0000 to 52.0000	±1.0	±0.5	±1.0	-30 to +85°C	+3.0±5%	—
XTCHH	TTS27VSC-A7	—								○
XNCJH	TTS18NSH-A7	3225								—
XTCJH	TTS18VSH-A7	—								○
XTCLH_E	TTS14VSE-A13	5032		10.0000 to 40.0000	±0.5	±0.2	±0.5	-40 to +85°C		○
XTCLH_J	TTS14VSH									—

Part Number List

Series	Type	Part Number	Frequency (MHz)	Frequency Tolerance (ppm max.) [at 25°C±3°C]	Frequency Shift by Temperature (ppm max.) [Standard Condition: +25°C]	Frequency Aging (ppm max./Year)	Current Consumption (mA max.)	Frequency Controlled Range (ppm)
XNCHH	TTS27NSC-A7	XNCHH10M000TJEA2P0	10.0000	±1.0	±0.5 (-30 to +85°C)	±1.0	2	-
XNCHH	TTS27NSC-A7	XNCHH15M300TJEA0P0	15.3000	±1.0	±0.5 (-30 to +85°C)	±1.0	2	-
XNCHH	TTS27NSC-A7	XNCHH16M368TJEA4P0	16.3680	±1.0	±0.5 (-30 to +85°C)	±1.0	2	-
XNCHH	TTS27NSC-A7	XNCHH16M800TJEA3P0	16.8000	±1.0	±0.5 (-30 to +85°C)	±1.0	2	-
XNCHH	TTS27NSC-A7	XNCHH19M200TJEC1P0	19.2000	±1.0	±0.5 (-30 to +85°C)	±1.0	2	-
XNCHH	TTS27NSC-A7	XNCHH26M000TJEE5P0	26.0000	±1.0	±0.5 (-30 to +85°C)	±1.0	2	-
XNCHH	TTS27NSC-A7	XNCHH28M800TJEA1P0	28.8000	±1.0	±0.5 (-30 to +85°C)	±1.0	2	-
XNCHH	TTS27NSC-A7	XNCHH32M000TJEB5P0	32.0000	±1.0	±0.5 (-30 to +85°C)	±1.0	2	-
XNCHH	TTS27NSC-A7	XNCHH38M400TJEB3P0	38.4000	±1.0	±0.5 (-30 to +85°C)	±1.0	2	-
XNCHH	TTS27NSC-A7	XNCHH52M000TJEA1P0	52.0000	±1.0	±0.5 (-30 to +85°C)	±1.0	2	-
XTCHH	TTS27VSC-A7	XTCHH10M000TJEA3P0	10.0000	±1.0	±0.5 (-30 to +85°C)	±1.0	2	±5 min. to ±15 max.
XTCHH	TTS27VSC-A7	XTCHH15M300TJEA2P0	15.3000	±1.0	±0.5 (-30 to +85°C)	±1.0	2	±5 min. to ±15 max.
XTCHH	TTS27VSC-A7	XTCHH16M800TJEA2P0	16.8000	±1.0	±0.5 (-30 to +85°C)	±1.0	2	±5 min. to ±15 max.
XTCHH	TTS27VSC-A7	XTCHH19M200TJEB4P0	19.2000	±1.0	±0.5 (-30 to +85°C)	±1.0	2	±5 min. to ±15 max.
XTCHH	TTS27VSC-A7	XTCHH20M950TJEA0P0	20.9500	±1.0	±0.5 (-30 to +85°C)	±1.0	2	±5 min. to ±15 max.
XTCHH	TTS27VSC-A7	XTCHH21M250TJEA0P0	21.2500	±1.0	±0.5 (-30 to +85°C)	±1.0	2	±5 min. to ±15 max.
XTCHH	TTS27VSC-A7	XTCHH26M000TJEB1P0	26.0000	±1.0	±0.5 (-30 to +85°C)	±1.0	2	±5 min. to ±15 max.
XTCHH	TTS27VSC-A7	XTCHH28M800TJEA0P0	28.8000	±1.0	±0.5 (-30 to +85°C)	±1.0	2	±5 min. to ±15 max.
XTCHH	TTS27VSC-A7	XTCHH38M400TJEA1P0	38.4000	±1.0	±0.5 (-30 to +85°C)	±1.0	2	±5 min. to ±15 max.
XTCHH	TTS27VSC-A7	XTCHH52M000TJEA1P0	52.0000	±1.0	±0.5 (-30 to +85°C)	±1.0	2	±5 min. to ±15 max.
XNCJH	TTS18NSH-A7	XNCJH10M000TJEA8P0	10.0000	±1.0	±0.5 (-30 to +85°C)	±1.0	2	-
XNCJH	TTS18NSH-A7	XNCJH15M300TJEA0P0	15.3000	±1.0	±0.5 (-30 to +85°C)	±1.0	2	-
XNCJH	TTS18NSH-A7	XNCJH16M800TJEA1P0	16.8000	±1.0	±0.5 (-30 to +85°C)	±1.0	2	-
XNCJH	TTS18NSH-A7	XNCJH19M200TJEA5P0	19.2000	±1.0	±0.5 (-30 to +85°C)	±1.0	2	-
XNCJH	TTS18NSH-A7	XNCJH26M000TJEB4P0	26.0000	±1.0	±0.5 (-30 to +85°C)	±1.0	2	-
XNCJH	TTS18NSH-A7	XNCJH28M800TJEA1P0	28.8000	±1.0	±0.5 (-30 to +85°C)	±1.0	2	-
XNCJH	TTS18NSH-A7	XNCJH38M400TJEA3P0	38.4000	±1.0	±0.5 (-30 to +85°C)	±1.0	2	-
XNCJH	TTS18NSH-A7	XNCJH52M000TJEA0P0	52.0000	±1.0	±0.5 (-30 to +85°C)	±1.0	2	-
XTCJH	TTS18VSH-A7	XTCJH10M000TJEB0P0	10.0000	±1.0	±0.5 (-30 to +85°C)	±1.0	2	±5 min. to ±15 max.
XTCJH	TTS18VSH-A7	XTCJH15M300TJEA3P0	15.3000	±1.0	±0.5 (-30 to +85°C)	±1.0	2	±5 min. to ±15 max.
XTCJH	TTS18VSH-A7	XTCJH16M800TJEB0P0	16.8000	±1.0	±0.5 (-30 to +85°C)	±1.0	2	±5 min. to ±15 max.
XTCJH	TTS18VSH-A7	XTCJH19M200TJEB6P0	19.2000	±1.0	±0.5 (-30 to +85°C)	±1.0	2	±5 min. to ±15 max.
XTCJH	TTS18VSH-A7	XTCJH26M000TJEB4P0	26.0000	±1.0	±0.5 (-30 to +85°C)	±1.0	2	±5 min. to ±15 max.
XTCJH	TTS18VSH-A7	XTCJH28M800TJEA0P0	28.8000	±1.0	±0.5 (-30 to +85°C)	±1.0	2	±5 min. to ±15 max.
XTCJH	TTS18VSH-A7	XTCJH38M400TJEA3P0	38.4000	±1.0	±0.5 (-30 to +85°C)	±1.0	2	±5 min. to ±15 max.
XTCJH	TTS18VSH-A7	XTCJH52M000TJEA5P0	52.0000	±1.0	±0.5 (-30 to +85°C)	±1.0	2	±5 min. to ±15 max.
XTCLH_E	TTS14VSE-A13	XTCLH10M000TJEB4P0	10.0000	±1.0	±0.5 (-30 to +85°C)	±1.0	2	±3 min. to ±15 max.
XTCLH_E	TTS14VSE-A13	XTCLH13M000TJEA3P0	13.0000	±1.0	±0.5 (-30 to +85°C)	±1.0	2	±3 min. to ±15 max.
XTCLH_E	TTS14VSE-A13	XTCLH16M800TJED2P0	16.8000	±1.0	±0.5 (-30 to +85°C)	±1.0	2	±3 min. to ±15 max.
XTCLH_E	TTS14VSE-A13	XTCLH19M200TJEC4P0	19.2000	±1.0	±0.5 (-30 to +85°C)	±1.0	2	±3 min. to ±15 max.
XTCLH_E	TTS14VSE-A13	XTCLH20M000TJEB7P0	20.0000	±1.0	±0.5 (-30 to +85°C)	±1.0	2	±3 min. to ±15 max.
XTCLH_E	TTS14VSE-A13	XTCLH21M250TJEA0P0	21.2500	±1.0	±0.5 (-30 to +85°C)	±1.0	2	±3 min. to ±15 max.
XTCLH_E	TTS14VSE-A13	XTCLH26M000TJEA7P0	26.0000	±1.0	±0.5 (-30 to +85°C)	±1.0	2	±3 min. to ±15 max.
XTCLH_E	TTS14VSE-A13	XTCLH38M400TJEA0P0	38.4000	±1.0	±0.5 (-30 to +85°C)	±1.0	2	±3 min. to ±15 max.
XTCLH_E	TTS14VSE-A13	XTCLH40M000TJEB0P0	40.0000	±1.0	±0.5 (-30 to +85°C)	±1.0	2	±3 min. to ±15 max.
XTCLH_J	TTS14VSH	XTCLH19M200TJJC3P0	19.2000	±0.5	±0.2 (-40 to +85°C)	±0.5	3	±3 min. to ±6 max.
XTCLH_J	TTS14VSH	XTCLH25M000TJJA5P0	25.0000	±0.5	±0.2 (-40 to +85°C)	±0.5	3	±3 min. to ±6 max.
XTCLH_J	TTS14VSH	XTCLH26M000TJJA6P0	26.0000	±0.5	±0.2 (-40 to +85°C)	±0.5	3	±3 min. to ±6 max.

Standard Land Pattern Dimensions

XNCHH (TTS27NSC-A7)
 XTCHH (TTS27VSC-A7)

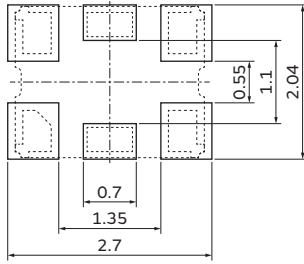

(in mm)

XNCJH (TTS18NSH-A7)
 XTCJH (TTS18VSH-A7)

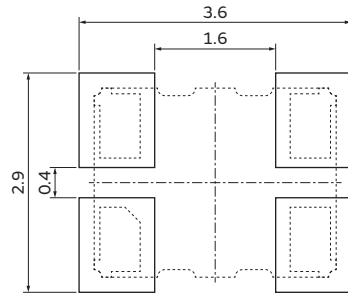

(in mm)

XTCLH_E (TTS14VSE-A13)
 XTCLH_J (TTS14VSH)

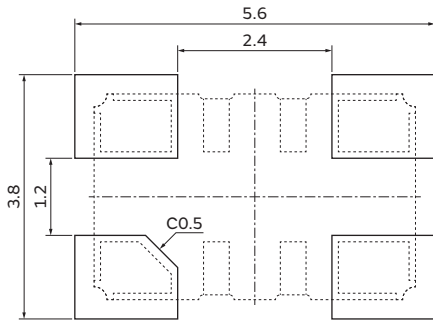

(in mm)

Notice -Crystal Oscillators for Industrial-

Notice (Soldering and Mounting)

1.1. Soldering Condition

(1) Reflow

Please mount components on a circuit board by the reflow soldering method.
 Flux: Please use rosin based flux; do not use water soluble flux.
 Solder: Please use solder (Sn-3.0Ag-0.5Cu) under the following condition.
 Standard thickness of soldering paste: 0.10 to 0.15mm

	Condition	
Pre-heating	150 to 180°C	60 to 120 sec.
Heating	220°C min.	30 to 60 sec.
Peak Temperature	245°C min. 260°C max. 5 sec. max.	

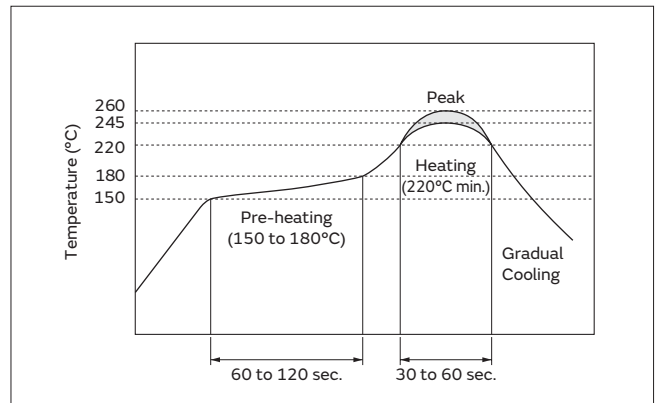

(2) Soldering Iron

If compelled to mount the component by using a soldering iron, please do not directly touch the component with the soldering iron. The component terminals or electrical characteristics may be damaged if excessive thermal stress is applied.

	Condition
Pre-heating	150°C 60 sec.
Heating of the Soldering Iron	350°C max.
Watt	30W max.
Shape of the Soldering Iron	ø3mm max.
Soldering Time	5 sec. max.
Solder	Sn-3.0Ag-0.5Cu

1.2. Optimum Solder Amount for Soldering

Please make the solder volume below the height of the substrate. When exceeding the substrate, damage to the sealing part between the metal cap and the substrate may occur.

2. Wash

The component cannot withstand washing.

3. Notice for Mounting

The component is recommended for placement machines employing optical placement capabilities. The component might be damaged by mechanical force depending on placement machine and condition. Make sure that you have evaluated by using placement machines before going into mass production. Do not use placement machines employing mechanical positioning. Please contact Murata for details beforehand.

Continued on the following page. ↗

Notice -Crystal Oscillators for Industrial-

Continued from the preceding page. ↘

Notice (Storage and Operating Condition)

1. Product Storage Condition

Please store the products in a room where the temperature/humidity is stable and avoid places where there are large temperature changes. Please store the products under the following conditions:

Temperature: -10 to + 40 degrees C

Humidity: 15 to 85% R.H.

2. Expire Date on Storage

Expiration date (shelf life) of the products is six months after delivery under the conditions of a sealed and unopened package. Please use the products within six months after delivery. If you store the products for a long time (more than six months), use carefully because the products may be degraded in solderability and/or rusty.

Please confirm solderability and characteristics for the products regularly.

3. Notice on Product Storage

- (1) Please do not store the products in a chemical atmosphere (Acids, Alkali, Bases, Organic gas, Sulfides and so on), because the characteristics may be reduced in quality, and/or be degraded in the solderability due to storage in a chemical atmosphere.

- (2) Please do not put the products directly on the floor without anything under them to avoid damp places and/or dusty places.

- (3) Please do not store the products in places such as in a damp heated place or any place exposed to direct sunlight or excessive vibration.

- (4) Please use the products immediately after the package is opened, because the characteristics may be reduced in quality, and/or be degraded in solderability due to storage under poor conditions.

- (5) Please do not drop the products to avoid cracking the crystal element.

4. Other

Conformal coating or washing of the component is not acceptable.

Please be sure to consult with our sales representative or engineer whenever and prior to using the products.

Notice (Rating)

The component may be damaged if excess mechanical stress is applied.

Notice (Handling)

1. Be sure to provide an appropriate fail-safe

function on your product to prevent secondary damage that may be caused by the abnormal function or the failure of our product.

2. Please do not use these products in the following

applications in transportation equipment (vehicles, trains, ships, etc.).

(example: engine control, brake control, steering control, body control.)

Packaging -Crystal Oscillators for Industrial-

Minimum Quantity/Dimensions of Reel

Plastic Tape $\phi 180\text{mm}$

3,000

(pcs.)

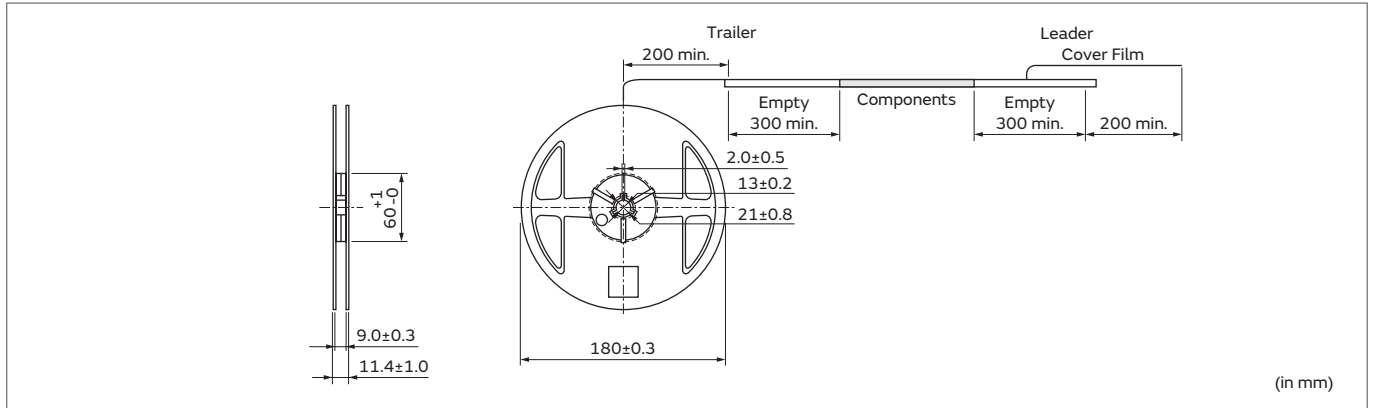

Dimensions of Taping

XNCHH (TTS27NSC-A7)
 XTCHH (TTS27VSC-A7)

Drawing Out Direction →

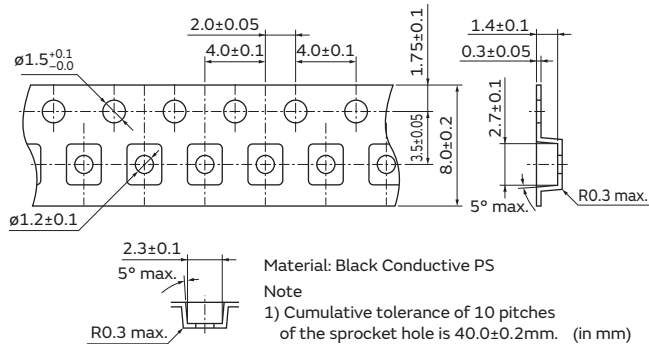

XNCJH (TTS18NSH-A7)
 XTCJH (TTS18VSH-A7)

Drawing Out Direction →

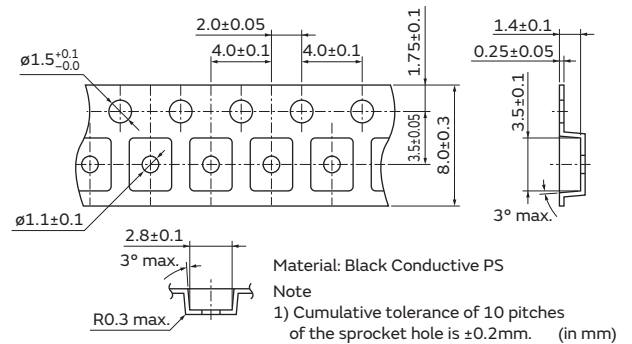

Packaging -Crystal Oscillators for Industrial-

Minimum Quantity/Dimensions of Reel

Plastic Tape $\varnothing 255\text{mm}$

3,000

(pcs.)

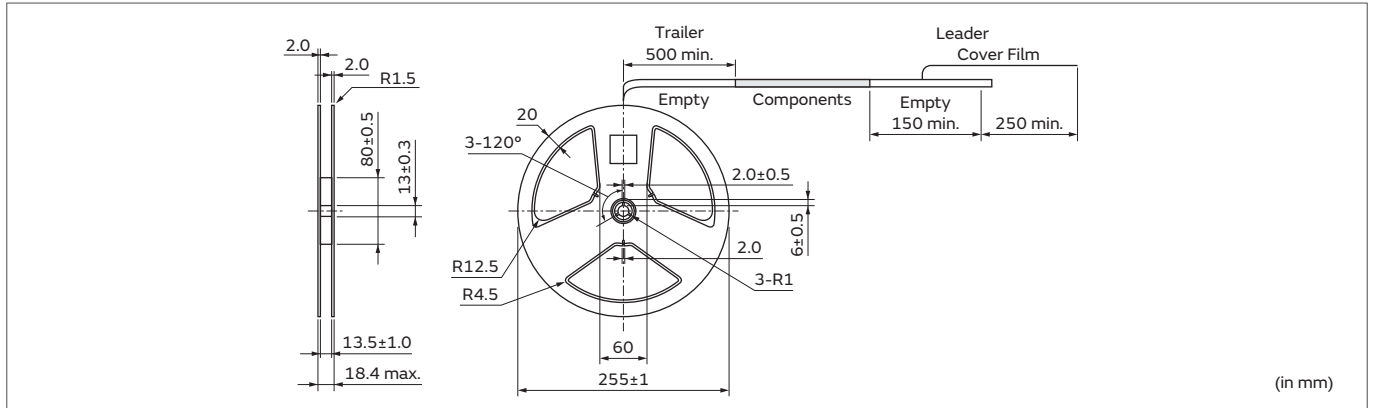

(in mm)

4

Dimensions of Taping

XTCLH_E (TTS14VSE-A13)
 XTCLH_J (TTS14VSH)

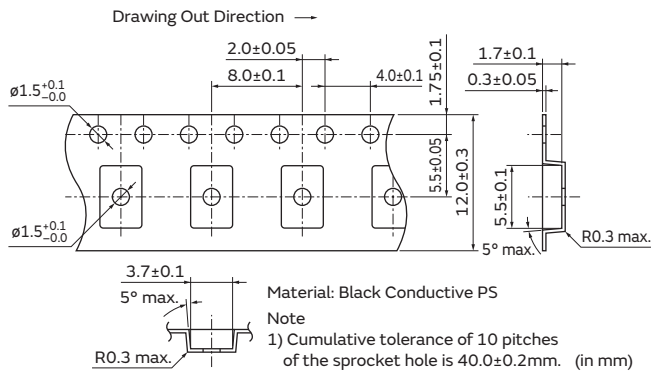

Measuring Circuit of Crystal Units

Measuring Circuit

1. Frequency Measuring Method

The load resonance frequency (Lower frequency of the two given when the electrical impedance of the component becomes resistant near its resonance point) is measured by network analyzer (Agilent E5100A or the equivalent) and the circuit in Figure 1. DUT is shown in Figure 2, and the value of Cs refers to the load capacitance value in specifications.

2. Equivalent Series Resistance

The equivalent series resistance (R1) is measured by network analyzer (Agilent E5100A or equivalent) and the circuit in Figure 1. DUT is shown in Figure 3.

3. Measuring Condition

Standard conditions for measurement shall be $+25\pm 3^{\circ}\text{C}$ temperature and humidity of 45 to 85%R.H.

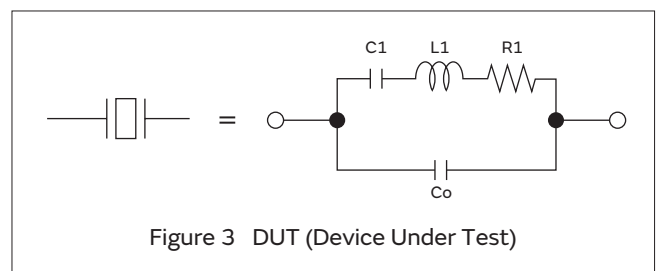
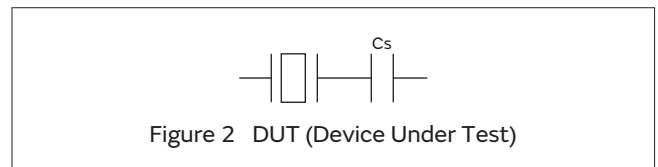
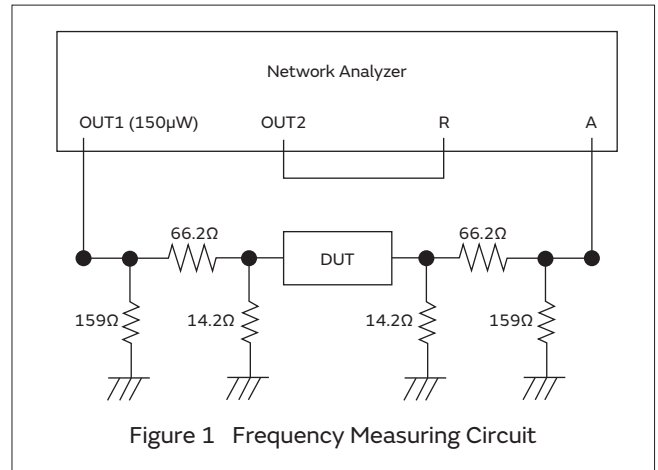

Global Locations

For details please visit www.murata.com

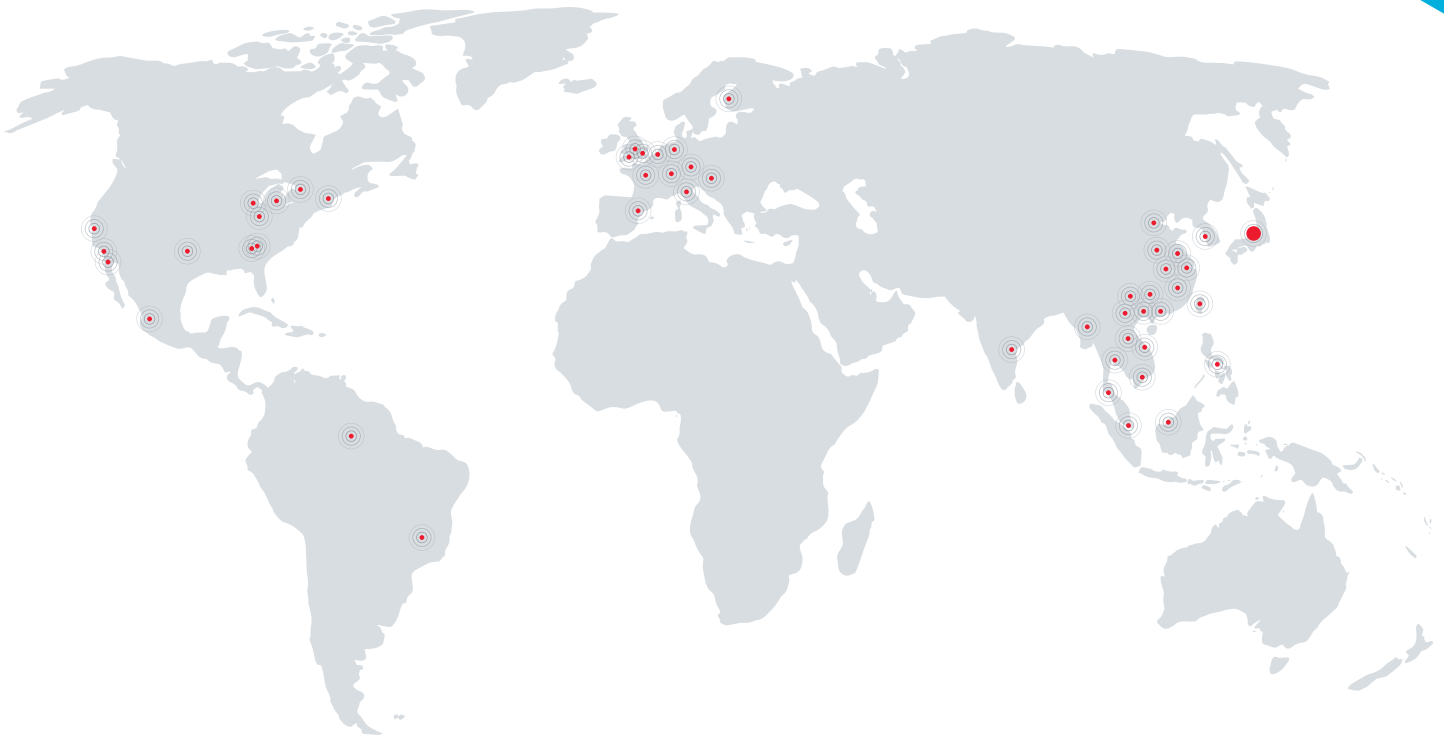

⚠ Note

1 Export Control

For customers outside Japan:

No Murata products should be used or sold, through any channels, for use in the design, development, production, utilization, maintenance or operation of, or otherwise contribution to (1) any weapons (Weapons of Mass Destruction [nuclear, chemical or biological weapons or missiles] or conventional weapons) or (2) goods or systems specially designed or intended for military end-use or utilization by military end-users.

For customers in Japan:

For products which are controlled items subject to the "Foreign Exchange and Foreign Trade Law" of Japan, the export license specified by the law is required for export.

2 Please contact our sales representatives or product engineers before using the products in this catalog for the applications listed below, which require especially high reliability for the prevention of defects which might directly damage a third party's life, body or property, or when one of our products is intended for use in applications other than those specified in this catalog.

- ① Aircraft equipment
- ② Aerospace equipment
- ③ Undersea equipment
- ④ Power plant equipment
- ⑤ Medical equipment
- ⑥ Transportation equipment (vehicles, trains, ships, etc.)
- ⑦ Traffic signal equipment
- ⑧ Disaster prevention / crime prevention equipment
- ⑨ Data-processing equipment
- ⑩ Application of similar complexity and/or reliability requirements to the applications listed above

3 Product specifications in this catalog are as of December 2015. They are subject to change or our products in it may be discontinued without advance notice. Please check with our sales representatives or product engineers before ordering. If there are any questions, please contact our sales representatives or product engineers.

4 Please read rating and ⚠CAUTION (for storage, operating, rating, soldering, mounting and handling) in this catalog to prevent smoking and/or burning, etc.

5 This catalog has only typical specifications. Therefore, please approve our product specifications or transact the approval sheet for product specifications before ordering.

6 Please note that unless otherwise specified, we shall assume no responsibility whatsoever for any conflict or dispute that may occur in connection with the effect of our and/or a third party's intellectual property rights and other related rights in consideration of your use of our products and/or information described or contained in our catalogs. In this connection, no representation shall be made to the effect that any third parties are authorized to use the rights mentioned above under licenses without our consent.

7 No ozone depleting substances (ODS) under the Montreal Protocol are used in our manufacturing process.

Murata Manufacturing Co., Ltd.

www.murata.com

muRata
INNOVATOR IN ELECTRONICS



Компания «ЭлектроПласт» предлагает заключение долгосрочных отношений при поставках импортных электронных компонентов на взаимовыгодных условиях!

Наши преимущества:

- Оперативные поставки широкого спектра электронных компонентов отечественного и импортного производства напрямую от производителей и с крупнейших мировых складов;
- Поставка более 17-ти миллионов наименований электронных компонентов;
- Поставка сложных, дефицитных, либо снятых с производства позиций;
- Оперативные сроки поставки под заказ (от 5 рабочих дней);
- Экспресс доставка в любую точку России;
- Техническая поддержка проекта, помощь в подборе аналогов, поставка прототипов;
- Система менеджмента качества сертифицирована по Международному стандарту ISO 9001;
- Лицензия ФСБ на осуществление работ с использованием сведений, составляющих государственную тайну;
- Поставка специализированных компонентов (Xilinx, Altera, Analog Devices, Intersil, Interpoint, Microsemi, Aeroflex, Peregrine, Syfer, Eurofarad, Texas Instrument, Miteq, Cobham, E2V, MA-COM, Hittite, Mini-Circuits, General Dynamics и др.);

Помимо этого, одним из направлений компании «ЭлектроПласт» является направление «Источники питания». Мы предлагаем Вам помощь Конструкторского отдела:

- Подбор оптимального решения, техническое обоснование при выборе компонента;
- Подбор аналогов;
- Консультации по применению компонента;
- Поставка образцов и прототипов;
- Техническая поддержка проекта;
- Защита от снятия компонента с производства.



Как с нами связаться

Телефон: 8 (812) 309 58 32 (многоканальный)

Факс: 8 (812) 320-02-42

Электронная почта: org@eplast1.ru

Адрес: 198099, г. Санкт-Петербург, ул. Калинина, дом 2, корпус 4, литера А.