

- High power block with excellent thermal convection
- Operating temperature -40°C to +92°
- Ultra wide 4:1 input voltage range
- EN 50155 approval for railway applications
- Excellent efficiency up to 91%
- Input filter meet EN 55022, class B
- I/O isolation up to 2121 VAC
- Under voltage lock-out circuit
- Protection against overvoltage, overtemperature and short circuit
- Output LED indicator

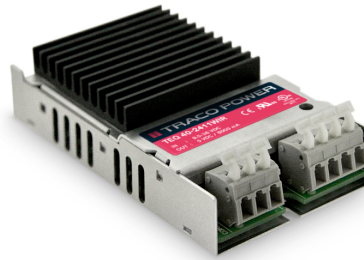

The TEQ 40WIR Series is a family of isolated high performance DC/DC converter modules with ultra-wide 4:1 input voltage ranges which come in a rugged metal case. These converters are suitable for a wide range of applications, but the product is designed particularly also for industrial applications where often no PCB mounting is possible but the module has to be mounted on a chassis. A very high efficiency and the heatsink construction allows an operating temperature up to +83°C with natural convection cooling without power derating and up to +92°C with power derating. Further features include under voltage lockout, over temperature protection and short circuit protection.

### Models

Order Code	Input Voltage Range	Output 1		Output 2		Efficiency typ.
		Vnom	I <sub>max</sub>	Vnom	I <sub>max</sub>	
TEQ 40-2411WIR	9.5 - 36 VDC (24 VDC nom.)	5 VDC	8'000 mA			90 %
TEQ 40-2412WIR		12 VDC	3'330 mA			91 %
TEQ 40-2413WIR		15 VDC	2'670 mA			91 %
TEQ 40-2415WIR		24 VDC	1'670 mA			90 %
TEQ 40-2422WIR		+12 VDC	1'670 mA	-12 VDC	1'670 mA	89 %
TEQ 40-2423WIR		+15 VDC	1'330 mA	-15 VDC	1'330 mA	89 %
TEQ 40-2425WIR		+24 VDC	830 mA	-24 VDC	830 mA	90 %
TEQ 40-4811WIR	18 - 75 VDC (48 VDC nom.)	5 VDC	8'000 mA			90 %
TEQ 40-4812WIR		12 VDC	3'330 mA			91 %
TEQ 40-4813WIR		15 VDC	2'670 mA			91 %
TEQ 40-4815WIR		24 VDC	1'670 mA			90 %
TEQ 40-4822WIR		+12 VDC	1'670 mA	-12 VDC	1'670 mA	89 %
TEQ 40-4823WIR		+15 VDC	1'330 mA	-15 VDC	1'330 mA	89 %
TEQ 40-4825WIR		+24 VDC	830 mA	-24 VDC	830 mA	90 %
TEQ 40-7211WIR	43 - 160 VDC (110 VDC nom.)	5 VDC	8'000 mA			88 %
TEQ 40-7212WIR		12 VDC	3'330 mA			90 %
TEQ 40-7213WIR		15 VDC	2'670 mA			90 %
TEQ 40-7215WIR		24 VDC	1'670 mA			89 %
TEQ 40-7222WIR		+12 VDC	1'670 mA	-12 VDC	1'670 mA	88 %
TEQ 40-7223WIR		+15 VDC	1'330 mA	-15 VDC	1'330 mA	88 %
TEQ 40-7225WIR		+24 VDC	830 mA	-24 VDC	830 mA	90 %

### Input Specifications

Input Current	- At no load	24 Vin models: <b>19 mA typ.</b> 48 Vin models: <b>14 mA typ.</b> 110 Vin models: <b>10 mA typ.</b>
Surge Voltage		24 Vin models: <b>50 VDC max.</b> (1 s max.) 48 Vin models: <b>100 VDC max.</b> (1 s max.) 110 Vin models: <b>170 VDC max.</b> (1 s max.)
Input Inrush Current		<b>15 A typ.</b>
Under Voltage Lockout		24 Vin models: <b>7 VDC min. / 8 VDC typ. / 9 VDC max.</b> 48 Vin models: <b>15 VDC min. / 16 VDC typ. / 17.5 VDC max.</b> 110 Vin models: <b>37 VDC min. / 40 VDC typ. / 42 VDC max.</b>
Recommended Input Fuse		24 Vin models: <b>8'000 mA</b> (fast acting) 48 Vin models: <b>4'000 mA</b> (slow blow) 110 Vin models: <b>2'000 mA</b> (slow blow)
Reverse Voltage Protection		<b>Parallel diode</b>

### Output Specifications

Voltage Set Accuracy		<b>±1% max.</b> (Single Output) <b>+1% / -1.2%</b> (Dual Output)
Regulation	- Input Variation (Vmin - Vmax)  - Load Variation (0 - 100%)  - Cross Regulation (25% / 100% asym. load)	single output models: <b>0.5% max.</b> dual output models: <b>0.5% max.</b> single output models: <b>1.5% max.</b> (5 VDC models) <b>1% max.</b> (other models) dual output models: <b>1% max.</b> (Output 1) <b>1% max.</b> (Output 2) dual output models: <b>5% max.</b>
Ripple and Noise (20 MHz Bandwidth)	- single output  - dual output	5 Vout models: <b>75 mVp-p max.</b> 12 Vout models: <b>100 mVp-p max.</b> 15 Vout models: <b>100 mVp-p max.</b> 24 Vout models: <b>150 mVp-p max.</b> 12 / -12 Vout models: <b>100 / 100 mVp-p max.</b> 15 / -15 Vout models: <b>100 / 100 mVp-p max.</b> 24 / -24 Vout models: <b>150 / 150 mVp-p max.</b>
Capacitive Load	- single output  - dual output	5 Vout models: <b>20'000 µF max.</b> 12 Vout models: <b>3'900 µF max.</b> 15 Vout models: <b>2'600 µF max.</b> 24 Vout models: <b>1'300 µF max.</b> 12 / -12 Vout models: <b>2'600 / 2'600 µF max.</b> 15 / -15 Vout models: <b>1'600 / 1'600 µF max.</b> 24 / -24 Vout models: <b>650 / 650 µF max.</b>
Minimum Load		<b>Not required</b>
Temperature Coefficient		<b>±0.02 %/K max.</b>
Hold-up Time		<b>10 ms min.</b>
Start-up Time		<b>100 ms typ.</b>
Short Circuit Protection		<b>Continuous, Automatic recovery</b>
Output Current Limitation		<b>150% typ. of Iout max.</b>
Oversvoltage Protection		<b>125% typ. of Vout nom.</b>
Transient Response	- Response Time	<b>250 µs typ.</b> (25% Load Step)

All specifications valid at nominal voltage, full load and +25°C after warm-up time unless otherwise stated.

### Safety Specifications

Safety Standards	- IT / Multimedia Equipment	IEC 60950-1 EN 60950-1 UL 60950-1
	- Industrial Control Equipment	UL 508 (single output models only)
	- Railway Applications	EN 50155
	- Certification Documents	<a href="http://www.tracopower.com/overview/teq40wir">www.tracopower.com/overview/teq40wir</a>
Pollution Degree		PD 2

### EMC Specifications

EMI Emissions	- Conducted Emissions	EN 50121-3-2 (EMC for Rolling Stock) EN 55032 class B (internal filter)
	- Radiated Emissions	EN 55032 class B (internal filter)
EMS Immunity	- Electrostatic Discharge	EN 50155 (Railway Applications) EN 50121-3-2 (EMC for Rolling Stock) EN 55024 (IT Equipment) Air: EN 61000-4-2, $\pm 8$ kV, perf. criteria A Contact: EN 61000-4-2, $\pm 6$ kV, perf. criteria A
	- RF Electromagnetic Field	EN 61000-4-3, 20 V/m, perf. criteria A
	- EFT (Burst)	EN 61000-4-4, $\pm 2$ kV, perf. criteria A
	- Surge	EN 61000-4-5, $\pm 1$ kV, perf. criteria A
	- Conducted RF Disturbances	EN 61000-4-6, 10 Vrms, perf. criteria A
	- PF Magnetic Field	Continuous: EN 61000-4-8, 100 A/m, perf. criteria A

### General Specifications

Relative Humidity		95% max. (non condensing)
Temperature Ranges	- Operating Temperature	-40°C to +83°C
	- Storage Temperature	-40°C to +105°C
Power Derating	- High Temperature	See application note: <a href="http://www.tracopower.com/overview/teq40wir">www.tracopower.com/overview/teq40wir</a>
Over Temperature Protection Switch Off		105°C min. / 115°C typ. / 120°C max. (Automatic recovery)
Cooling System		Natural convection (20 LFM)
Altitude During Operation		2'000 m max.
Switching Frequency		225 - 275 kHz (PWM)
		250 kHz typ. (PWM)
Insulation System		Functional Insulation
Isolation Test Voltage	- Input to Output, 60 s	2'121 VAC
	- Input to Case, 60 s	1'414 VAC
	- Output to Case, 60 s	1'414 VAC
Isolation Resistance	- Input to Output, 500 VDC	1'000 MOhm min.
Isolation Capacitance	- Input to Output, 100 kHz, 1 V	5'000 pF typ.
Reliability	- Calculated MTBF	1'000'000 h (MIL-HDBK-217F, ground benign)
Environment	- Vibration	MIL-STD-810F EN 61373
	- Mechanical Shock	MIL-STD-810F EN 61373
	- Thermal Shock	MIL-STD-810F
Housing Material		Aluminium
Connection Type		Clip
Weight		129 g
Status Indicator		Green LED
Environmental Compliance	- Reach	<a href="http://www.tracopower.com/info/reach-declaration.pdf">www.tracopower.com/info/reach-declaration.pdf</a>
	- RoHS	<a href="http://www.tracopower.com/info/rohs-declaration.pdf">www.tracopower.com/info/rohs-declaration.pdf</a>
	- Flammability (EN 45545-2)	<a href="http://www.tracopower.com/info/en45545-declaration.pdf">www.tracopower.com/info/en45545-declaration.pdf</a>

All specifications valid at nominal voltage, full load and +25°C after warm-up time unless otherwise stated.

### Supporting Documents

[Overview Link](#) (for additional Documents)

[www.tracopower.com/overview/teq40wir](http://www.tracopower.com/overview/teq40wir)

### Outline Dimensions

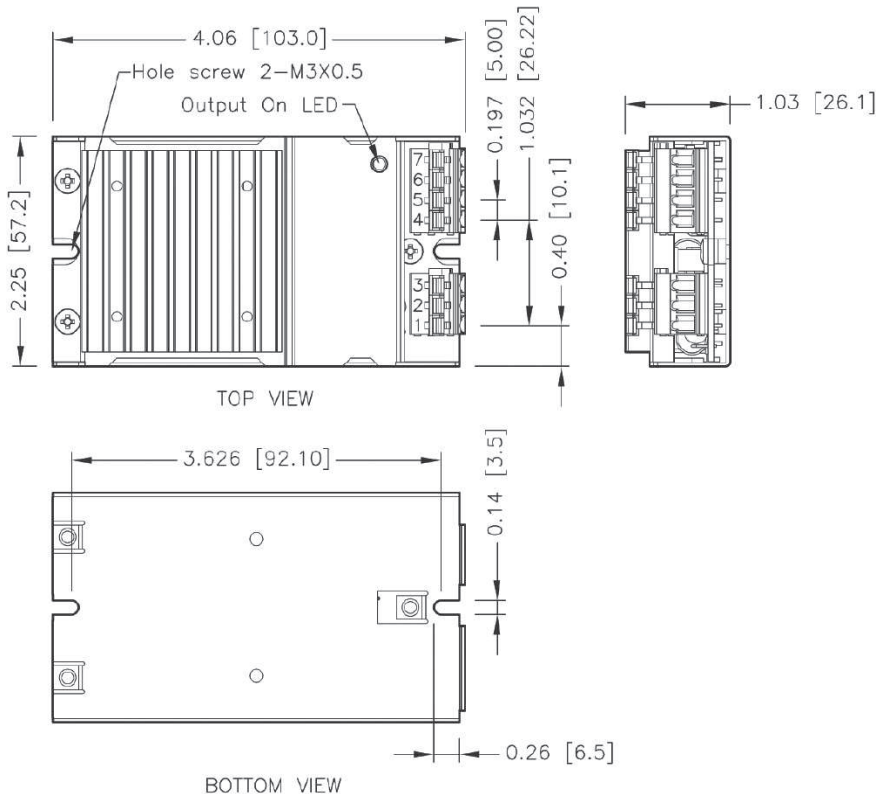

Pinout		
Pin	Single Output	Dual Output
1	+Vin	+Vin
2	-Vin (GND)	-Vin (GND)
3	NC	NC
4	NC	-Vout
5	-Vout	Common
6	+Vout	Common
7	NC	+Vout

NC: No Connection

Dimensions in inch [mm]

Tolerances: x.x ±0.02 [±0.5]

x.xx ±0.01 [±0.25]

Screw max. torque: 5.0 kgf - cm (0.49 Nm)

Spring terminals: 12 - 18 AWG



Компания «ЭлектроПласт» предлагает заключение долгосрочных отношений при поставках импортных электронных компонентов на взаимовыгодных условиях!

Наши преимущества:

- Оперативные поставки широкого спектра электронных компонентов отечественного и импортного производства напрямую от производителей и с крупнейших мировых складов;
- Поставка более 17-ти миллионов наименований электронных компонентов;
- Поставка сложных, дефицитных, либо снятых с производства позиций;
- Оперативные сроки поставки под заказ (от 5 рабочих дней);
- Экспресс доставка в любую точку России;
- Техническая поддержка проекта, помощь в подборе аналогов, поставка прототипов;
- Система менеджмента качества сертифицирована по Международному стандарту ISO 9001;
- Лицензия ФСБ на осуществление работ с использованием сведений, составляющих государственную тайну;
- Поставка специализированных компонентов (Xilinx, Altera, Analog Devices, Intersil, Interpoint, Microsemi, Aeroflex, Peregrine, Syfer, Eurofarad, Texas Instrument, Miteq, Cobham, E2V, MA-COM, Hittite, Mini-Circuits, General Dynamics и др.);

Помимо этого, одним из направлений компании «ЭлектроПласт» является направление «Источники питания». Мы предлагаем Вам помощь Конструкторского отдела:

- Подбор оптимального решения, техническое обоснование при выборе компонента;
- Подбор аналогов;
- Консультации по применению компонента;
- Поставка образцов и прототипов;
- Техническая поддержка проекта;
- Защита от снятия компонента с производства.



#### Как с нами связаться

**Телефон:** 8 (812) 309 58 32 (многоканальный)

**Факс:** 8 (812) 320-02-42

**Электронная почта:** [org@eplast1.ru](mailto:org@eplast1.ru)

**Адрес:** 198099, г. Санкт-Петербург, ул. Калинина, дом 2, корпус 4, литера А.