

THIS COPY IS PROVIDED ON A RESTRICTED BASIS AND IS NOT TO BE USED IN ANY WAY DETRIMENTAL TO THE INTERESTS OF PANDUIT CORP.

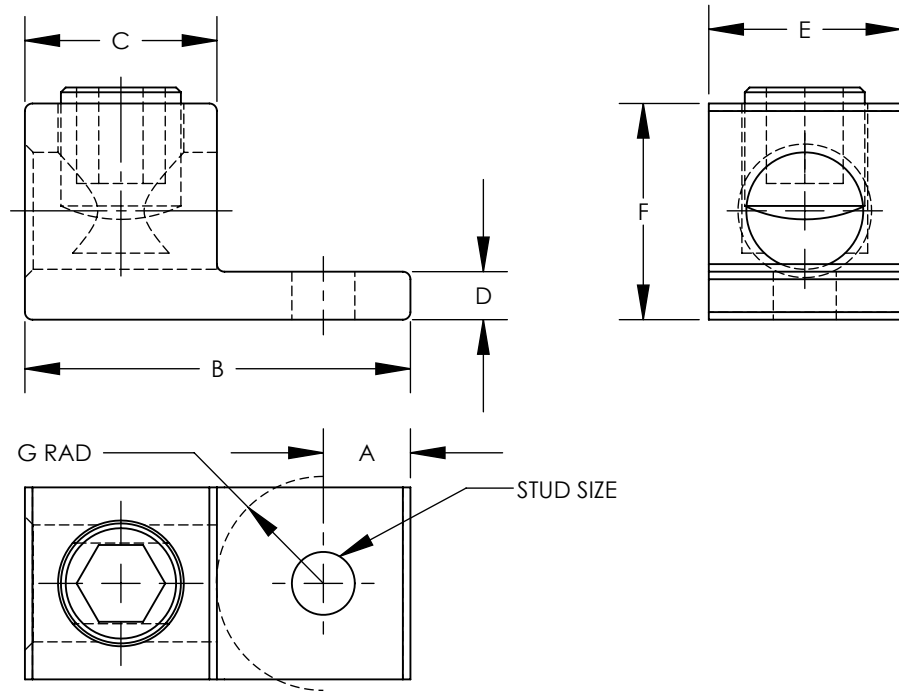

NOTES:

- MATERIAL:
BODY - ALUMINUM, TIN PLATED
SCREW - ALUMINUM, TIN PLATED
(NOTE: LAMA6-14-QY & LAMA2-14-QY HAVE ZINC PLATED STEEL SCREWS)
- cULus LISTED FOR USE UP TO 600V & TEMPERATURE RATED 90°C (AL9CU)
- DUAL RATED FOR USE WITH COPPER OR ALUMINUM STRANDED CODE CONDUCTOR
- THESE PARTS ARE RoHS COMPLIANT
- USE OF OXIDE INHIBITING JOINT COMPOUND LIKE PANDUIT CMP-100 RECOMMENDED FOR PAD TO PAD AND CONDUCTOR SURFACES
- SEE PACKAGING LABEL FOR TIGHTENING TORQUE INFORMATION
- PKG QTY:
Q = 25



K

PART NUMBER	WIRE RANGE COPPER/ALUMINUM	WIRE STRIP LENGTH IN[mm]	STUD SIZE IN	DIMENSIONS - IN [mm] +/- .02 [.5]							HEX KEY*
				A	B	C	D	E	F	G	
LAMA6-14-QY	14 AWG - 6 AWG	.38 [9.7]	1/4	.25 [6.4]	1.06 [27.0]	.38 [9.7]	.09 [2.4]	.50 [12.7]	.50 [12.7]	.43 [10.9]	SLOTTED
LAMA2-14-QY	14 AWG - 2 AWG	.47 [11.9]	1/4	.31 [7.9]	1.16 [29.5]	.47 [11.9]	.10 [2.5]	.50 [12.7]	.55 [14.0]	.38 [9.7]	SLOTTED
LAMA1/0-14-QY	14 AWG - 1/0 AWG	.62 [15.7]	1/4	.42 [10.7]	1.47 [37.3]	.62 [15.7]	.19 [4.8]	.62 [15.7]	.79 [20.0]	.43 [10.9]	SLOTTED
LAMA1/0-56-Q	14 AWG - 1/0 AWG	.62 [15.7]	5/16	.25 [6.4]	1.47 [37.3]	.62 [15.7]	.19 [4.8]	.62 [15.7]	.79 [20.0]	.60 [15.2]	SLOTTED
LAMA2/0-14-QY	14 AWG - 2/0 AWG	.62 [15.7]	1/4	.44 [11.2]	1.47 [37.3]	.62 [15.7]	.19 [4.8]	.62 [15.8]	.79 [20.0]	.41 [10.4]	3/16
LAMA250-56-QY	6 AWG - 250 kcmil	1.00 [25.4]	5/16	.45 [11.5]	2.01 [51.0]	1.00 [25.4]	.25 [6.4]	1.00 [25.4]	1.13 [28.6]	.56 [14.2]	5/16

* HEX SIZE MAY DIFFER FROM CHART. DIFFERENCE IN SIZE WILL NOT AFFECT FIT, FORM, OR FUNCTION OF PART

12	3/12	JHNU	RGB	L. REVISED NOTE 1: ZINC PLATED SCREW WAS TIN PLATED	10N006AR-NC	RGB	RGB
11	4/11	JHNU	JHNU	K. ADDED +/- .02 [.5] TOLERANCE	10N006AR-NC	FLD	FLD
10	9/10	JHNU	JHNU	J. REVISED NOTES I. REMOVED FIGURE NO. COLUMN	10N006AR-NC	FLD	FLD
09	7/10	JHNU	JHNU	H. REVISED DWG NUMBER: 10N006AR-NC WAS C41566 G. REVISED LAMA6-14-QY DIM: E WAS .38 F. REVISED LAMA2-14-QY DIM'S: A WAS .32, D WAS .09, F WAS .56, G WAS .37 E. REVISED LAMA1/0-14-QY DIM'S: WIRE STRIP LENGTH WAS .63, A WAS .44, C WAS .63, F WAS .81, G WAS .40 D. REVISED LAMA1/0-56-Q DIM'S: WIRE STRIP LENGTH WAS .63, C WAS .63, E WAS .63, F WAS .78, G WAS .59 C. REVISED LAMA 2/0-14-QY DIM'S: WIRE STRIP LENGTH WAS .63, C WAS .63, F WAS .81, G WAS .40, HEX KEY WAS SLOTTED B. REVISED LAMA250-56-QY DIM'S: A WAS .44, B WAS 2.00, D WAS .22, E WAS .90, F WAS 1.06, HEX KEY WAS 3/8 A. REMOVED TORQUE COLUMN FROM TABLE	10N006AR-NC	FLD	FLD
08	9/09	JHNU	JHNU	ADDED LAMA1/0-56 TO DRAWING			
REV	DATE	BY	CHK	DESCRIPTION	ECN	-R	SUP

10N006AR-NC/00D H

PANDUIT CORP. TINLEY PARK, ILLINOIS

LAMA SERIES 6AWG THRU 250kcmil
ALUMINUM MECHANICAL LUGS
CUSTOMER DRAWING

UNLESS OTHERWISE SPECIFIED
DIMENSIONAL TOLERANCES ARE:
(.X) ± --- (.XXX) ± ---
(.XX) ± --- ANGLES ± ---

UNLESS OTHERWISE SPECIFIED,
ALL DIMENSIONS ARE GIVEN IN
INCHES, THIRD ANGLE PROJECTION

DRAWN BY
JHNU

MAT'L:

SCALE
NONE

DATE
2/06

SEE NOTES

DRAWING NO / CAD FILE
10N006AR-NC

DWG
B
SIZE

H



Компания «ЭлектроПласт» предлагает заключение долгосрочных отношений при поставках импортных электронных компонентов на взаимовыгодных условиях!

Наши преимущества:

- Оперативные поставки широкого спектра электронных компонентов отечественного и импортного производства напрямую от производителей и с крупнейших мировых складов;
- Поставка более 17-ти миллионов наименований электронных компонентов;
- Поставка сложных, дефицитных, либо снятых с производства позиций;
- Оперативные сроки поставки под заказ (от 5 рабочих дней);
- Экспресс доставка в любую точку России;
- Техническая поддержка проекта, помощь в подборе аналогов, поставка прототипов;
- Система менеджмента качества сертифицирована по Международному стандарту ISO 9001;
- Лицензия ФСБ на осуществление работ с использованием сведений, составляющих государственную тайну;
- Поставка специализированных компонентов (Xilinx, Altera, Analog Devices, Intersil, Interpoint, Microsemi, Aeroflex, Peregrine, Syfer, Eurofarad, Texas Instrument, Miteq, Cobham, E2V, MA-COM, Hittite, Mini-Circuits, General Dynamics и др.);

Помимо этого, одним из направлений компании «ЭлектроПласт» является направление «Источники питания». Мы предлагаем Вам помощь Конструкторского отдела:

- Подбор оптимального решения, техническое обоснование при выборе компонента;
- Подбор аналогов;
- Консультации по применению компонента;
- Поставка образцов и прототипов;
- Техническая поддержка проекта;
- Защита от снятия компонента с производства.



Как с нами связаться

Телефон: 8 (812) 309 58 32 (многоканальный)

Факс: 8 (812) 320-02-42

Электронная почта: org@eplast1.ru

Адрес: 198099, г. Санкт-Петербург, ул. Калинина, дом 2, корпус 4, литера А.