



SANYO Semiconductors

# DATA SHEET

An ON Semiconductor Company

## LB1948MC

Monolithic Digital IC

12V Low Saturation Voltage Drive

Forward/Reverse Motor Driver

### Overview

The LB1948MC is a two-channel low saturation voltage forward/reverse motor driver IC. It is optimal for motor drive in 12V system products and can drive either two DC motors, one DC motor using parallel connection, or a two-phase bipolar stepping motor with 1-2 phase excitation mode drive.

### Features

- Supports 12V power supply systems
- Low saturation voltage:  $V_{O(sat)} = 0.5V$  (typical) at  $I_O = 400mA$
- Zero current drawn in standby mode
- Braking function
- Supports parallel connection:  $I_O \text{ max} = 1.6A$ ,  $V_{O(sat)} = 0.6V$  (typical) at  $I_O = 800mA$
- Built-in spark killer diode
- Built-in thermal shutdown circuit
- Miniature package: MFP-10S (6.4mm × 5.0mm)

### Specifications

**Absolute Maximum Ratings** at  $T_a = 25^\circ C$

Parameter	Symbol	Conditions	Ratings	Unit
Maximum supply voltage	$V_{CC \text{ max}}$		-0.3 to +20	V
Output voltage	$V_{OUT}$		-0.3 to +20	V
Input voltage	$V_{IN}$		-0.3 to +18	V
Ground pin source current	$I_{GND}$	Per channel	800	mA
Allowable power dissipation	$P_d \text{ max}$	Mounted on a specified board*	870	mW
Operating temperature	$T_{opr}$		-20 to +85	$^\circ C$
Storage temperature	$T_{stg}$		-40 to +150	$^\circ C$

\* Specified board: 114.3mm × 76.1mm × 1.6mm, glass epoxy board.

Caution 1) Absolute maximum ratings represent the value which cannot be exceeded for any length of time.

Caution 2) Even when the device is used within the range of absolute maximum ratings, as a result of continuous usage under high temperature, high current, high voltage, or drastic temperature change, the reliability of the IC may be degraded. Please contact us for the further details.

■ Any and all SANYO Semiconductor Co.,Ltd. products described or contained herein are, with regard to "standard application", intended for the use as general electronics equipment. The products mentioned herein shall not be intended for use for any "special application" (medical equipment whose purpose is to sustain life, aerospace instrument, nuclear control device, burning appliances, transportation machine, traffic signal system, safety equipment etc.) that shall require extremely high level of reliability and can directly threaten human lives in case of failure or malfunction of the product or may cause harm to human bodies, nor shall they grant any guarantee thereof. If you should intend to use our products for new introduction or other application different from current conditions on the usage of automotive device, communication device, office equipment, industrial equipment etc. , please consult with us about usage condition (temperature, operation time etc.) prior to the intended use. If there is no consultation or inquiry before the intended use, our customer shall be solely responsible for the use.

■ Specifications of any and all SANYO Semiconductor Co.,Ltd. products described or contained herein stipulate the performance, characteristics, and functions of the described products in the independent state, and are not guarantees of the performance, characteristics, and functions of the described products as mounted in the customer's products or equipment. To verify symptoms and states that cannot be evaluated in an independent device, the customer should always evaluate and test devices mounted in the customer's products or equipment.

**SANYO Semiconductor Co., Ltd.**

<http://semicon.sanyo.com/en/network>

# LB1948MC

## Allowable Operating Range at Ta = 25°C

Parameter	Symbol	Conditions	Ratings	Unit
Supply voltage	VCC		2.5 to 16	V
Input high-level voltage	V <sub>IH</sub>		1.8 to 10	V
Input low-level voltage	V <sub>IL</sub>		-0.3 to +0.7	V

## Electrical Characteristics at Ta = 25°C, VCC = 5V

Parameter	Symbol	Conditions	Ratings			Unit
			min	typ	max	
Current drain	I <sub>CC0</sub>	IN1, 2, 3, 4 = 0V (Standby mode)		0.1	10	μA
	I <sub>CC1</sub>	*1 (Forward or reverse mode)		15	21	mA
	I <sub>CC2</sub>	*2 (Brake mode)		30	40	mA
Output saturation voltage	V <sub>O(sat)1</sub>	I <sub>OUT</sub> = 200mA (High Side and Low Side)		0.25	0.35	V
	V <sub>O(sat)2</sub>	I <sub>OUT</sub> = 400mA (High Side and Low Side)		0.50	0.75	V
Input current	I <sub>IN</sub>	V <sub>IN</sub> = 5V		85	110	μA
<b>Spark Killer Diode</b>						
Reverse current	I <sub>S(leak)</sub>				30	μA
Forward voltage	V <sub>SF</sub>	I <sub>OUT</sub> = 400mA			1.7	V

\*1:IN1/IN2/IN3/IN4=H/L/L/L or L/H/L/L or L/L/H/L or L/L/L/H.

\*2:IN1/IN2/IN3/IN4=H/H/L/L or L/L/H/H.

## Package Dimensions

unit : mm (typ)

3420

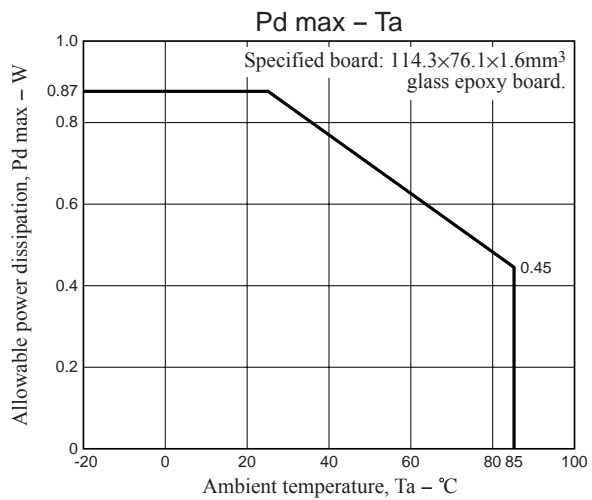
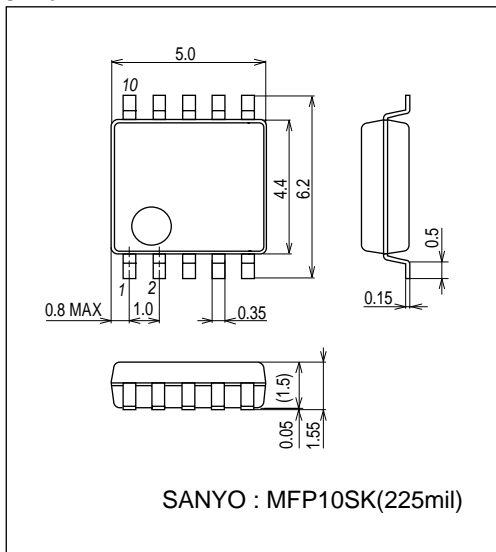

## Pin Assignment

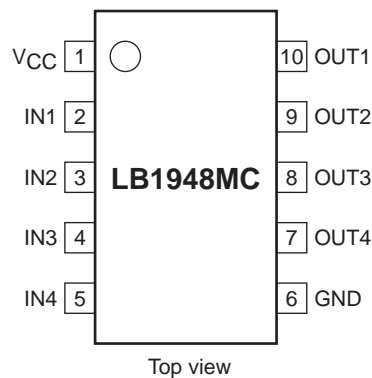

# LB1948MC

## Truth Table

Input				Output				Notes
IN1	IN2	IN3	IN4	OUT1	OUT2	OUT3	OUT4	
L	L	L	L	OFF	OFF	OFF	OFF	Standby mode
L	L			OFF	OFF			Standby mode
H	L			H	L			Forward
L	H			L	H			Reverse
H	H			L	L			Brake
				L	L			OFF
		H	L	H	L	Forward		
		L	H	L	H	Reverse		
		H	H	L	L	Brake		

## Block Diagram

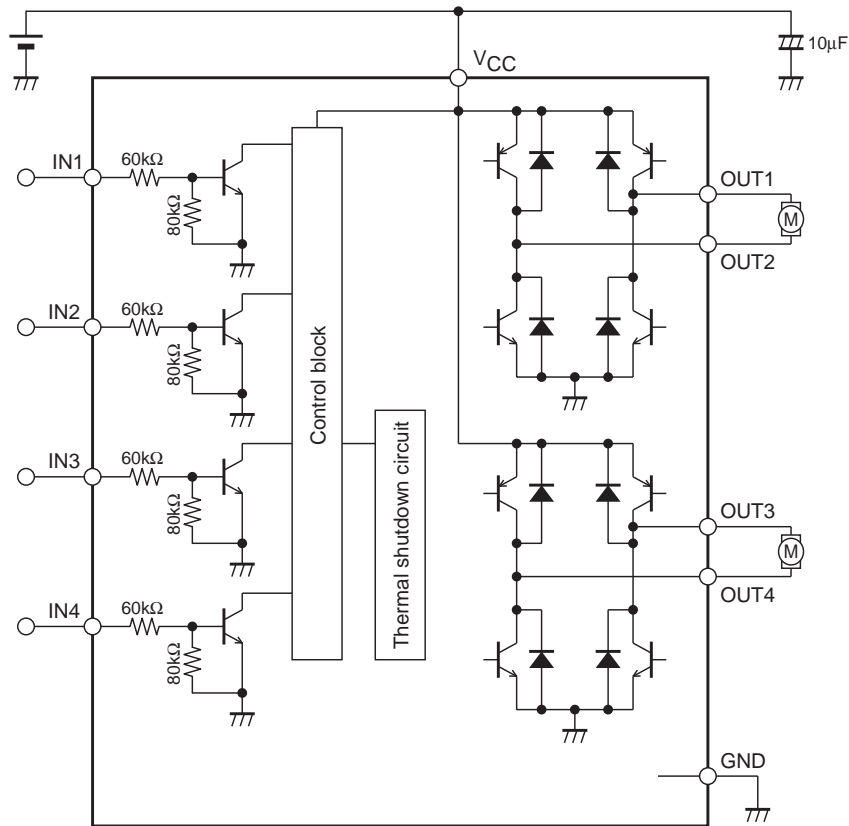

## Design Documentation

### (1) Voltage magnitude relationship

There are no restrictions on the magnitude relationships between the voltages applied to  $V_{CC}$  and IN1 to IN4.

### (2) Parallel connection

The LB1948MC can be used as a single-channel H-bridge power supply by connecting IN1 to IN3, IN2 to IN4, OUT1 to OUT3, and OUT2 to OUT4 as shown in the figure. ( $I_{Omax} = 1.6A$ ,  $V_O(sat) = 0.6V$  (typical) at  $I_O = 800mA$ )

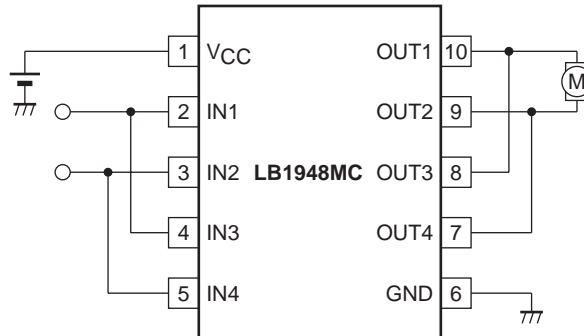

### (3) Observe the following points when designing the printed circuit board pattern layout.

- Make the  $V_{CC}$  and ground lines as wide and as short as possible to lower the wiring inductance.
- Insert bypass capacitors between  $V_{CC}$  and ground mounted as close as possible to the IC.
- Resistors of about  $10K\Omega$  must be inserted between the CPU output ports and the IN1 to IN4 pins if the microcontroller and the LB1948MC are mounted on different printed circuit boards and the ground potentials differ significantly.

### (4) Penetration electric current

At the time of the next mode shift, a penetration electric current is generated in  $V_{CC}$ -GND. There are not the deterioration of the IC by, the destruction as follows 1A<sub>typ</sub> per this penetration electric current (1ch, 1 $\mu$ s; but for the stabilization of the power supply line of the IC is most recent, and, please can enter with a condenser.

- (i) Forward (Reverse)  $\leftrightarrow$  Brake
- (ii) Forward  $\leftrightarrow$  Reverse
- (iii) Standby  $\rightarrow$  Brake

In addition, the penetration electric current disappears when I put a wait mode of 10 $\mu$ s at the time of the change of the Forward  $\leftrightarrow$  Reverse.

### (5) Supplementary matter of the penetration electric current

According to (4), a penetration electric current cannot influence IC life.

## Thermal Shutdown Temperature

### (1) Thermal shutdown temperature

The thermal shutdown temperature  $T_{sd}$  is  $200 \pm 20^\circ C$  with fluctuations.

### (2) Thermal shutdown operation

The operation of the thermal shutdown circuit is shown in the figure below.

When the chip temperature  $T_j$  is in the direction of increasing (solid line), the output turns off at approximately  $200^\circ C$ .

When the chip temperature  $T_j$  is in the direction of decreasing (dotted line), the output turns on (returns) at approximately  $125^\circ C$ .

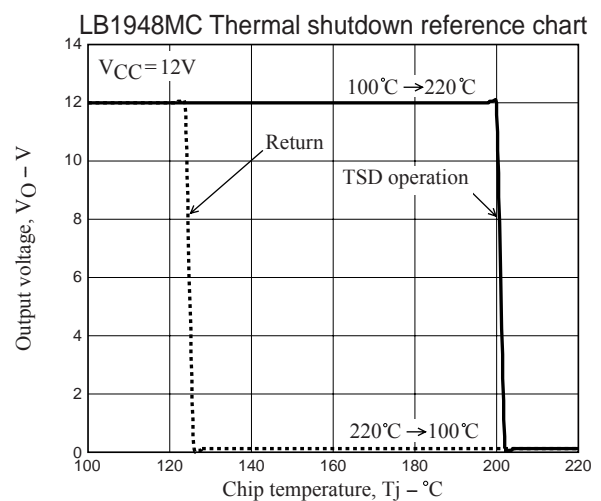

## Thermal Shutdown Circuit Block Diagram

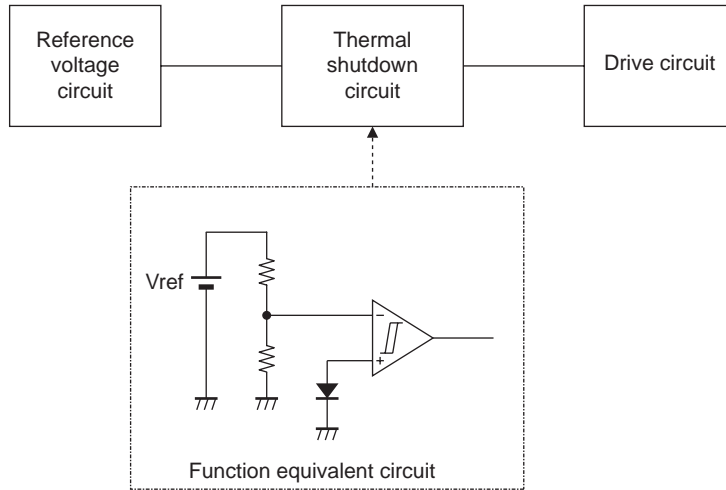

Note: The above is an example of thermal shutdown circuits although there are some differences from the actual internal circuit.

## Thermal Shutdown Operation

The thermal shutdown circuit compares the voltage of the heat sensitive element (diode) with the reference voltage and shuts off the drive circuit at a certain temperature to protect the IC chip from overheating.

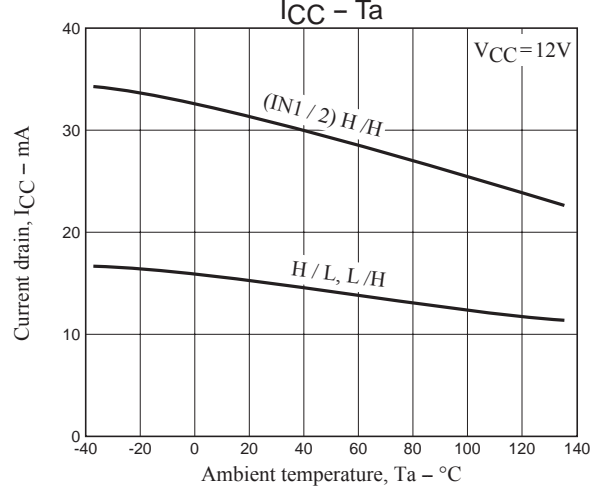
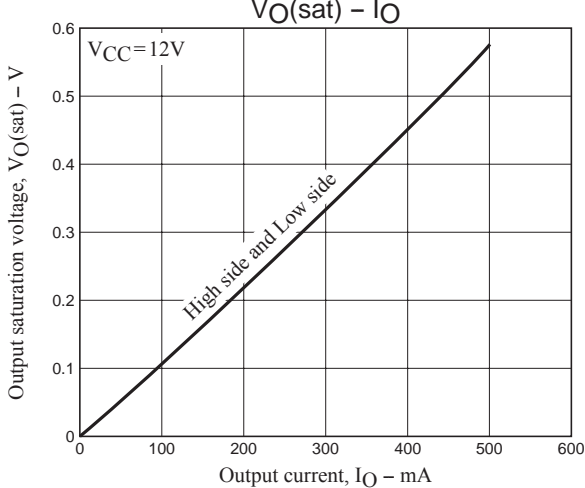
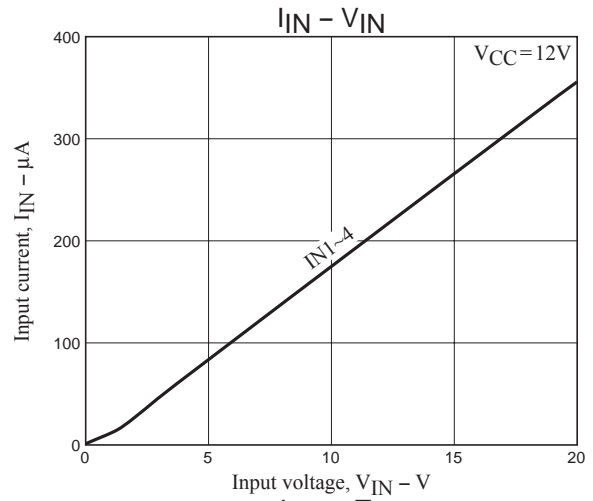
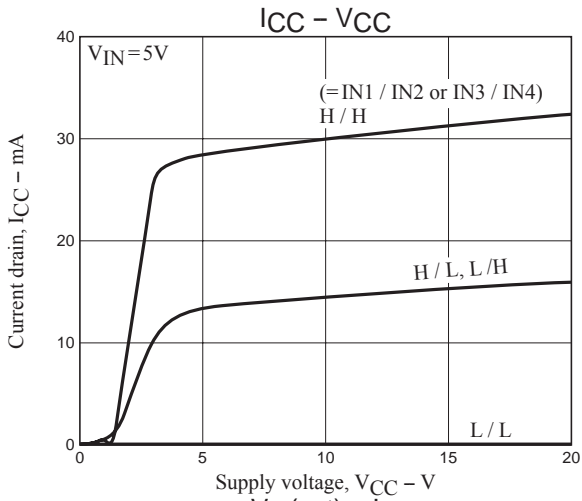

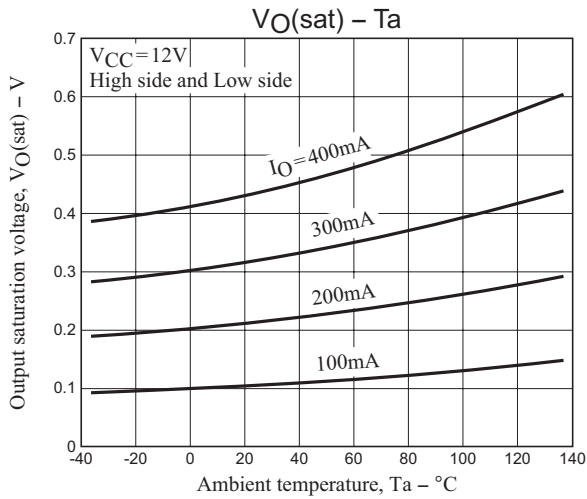

- SANYO Semiconductor Co.,Ltd. assumes no responsibility for equipment failures that result from using products at values that exceed, even momentarily, rated values (such as maximum ratings, operating condition ranges, or other parameters) listed in products specifications of any and all SANYO Semiconductor Co.,Ltd. products described or contained herein.
- SANYO Semiconductor Co.,Ltd. strives to supply high-quality high-reliability products, however, any and all semiconductor products fail or malfunction with some probability. It is possible that these probabilistic failures or malfunction could give rise to accidents or events that could endanger human lives, trouble that could give rise to smoke or fire, or accidents that could cause damage to other property. When designing equipment, adopt safety measures so that these kinds of accidents or events cannot occur. Such measures include but are not limited to protective circuits and error prevention circuits for safe design, redundant design, and structural design.
- In the event that any or all SANYO Semiconductor Co.,Ltd. products described or contained herein are controlled under any of applicable local export control laws and regulations, such products may require the export license from the authorities concerned in accordance with the above law.
- No part of this publication may be reproduced or transmitted in any form or by any means, electronic or mechanical, including photocopying and recording, or any information storage or retrieval system, or otherwise, without the prior written consent of SANYO Semiconductor Co.,Ltd.
- Any and all information described or contained herein are subject to change without notice due to product/technology improvement, etc. When designing equipment, refer to the "Delivery Specification" for the SANYO Semiconductor Co.,Ltd. product that you intend to use.
- Upon using the technical information or products described herein, neither warranty nor license shall be granted with regard to intellectual property rights or any other rights of SANYO Semiconductor Co.,Ltd. or any third party. SANYO Semiconductor Co.,Ltd. shall not be liable for any claim or suits with regard to a third party's intellectual property rights which has resulted from the use of the technical information and products mentioned above.

This catalog provides information as of March, 2012. Specifications and information herein are subject to change without notice.



Компания «ЭлектроПласт» предлагает заключение долгосрочных отношений при поставках импортных электронных компонентов на взаимовыгодных условиях!

Наши преимущества:

- Оперативные поставки широкого спектра электронных компонентов отечественного и импортного производства напрямую от производителей и с крупнейших мировых складов;
- Поставка более 17-ти миллионов наименований электронных компонентов;
- Поставка сложных, дефицитных, либо снятых с производства позиций;
- Оперативные сроки поставки под заказ (от 5 рабочих дней);
- Экспресс доставка в любую точку России;
- Техническая поддержка проекта, помощь в подборе аналогов, поставка прототипов;
- Система менеджмента качества сертифицирована по Международному стандарту ISO 9001;
- Лицензия ФСБ на осуществление работ с использованием сведений, составляющих государственную тайну;
- Поставка специализированных компонентов (Xilinx, Altera, Analog Devices, Intersil, Interpoint, Microsemi, Aeroflex, Peregrine, Syfer, Eurofarad, Texas Instrument, Miteq, Cobham, E2V, MA-COM, Hittite, Mini-Circuits, General Dynamics и др.);

Помимо этого, одним из направлений компании «ЭлектроПласт» является направление «Источники питания». Мы предлагаем Вам помощь Конструкторского отдела:

- Подбор оптимального решения, техническое обоснование при выборе компонента;
- Подбор аналогов;
- Консультации по применению компонента;
- Поставка образцов и прототипов;
- Техническая поддержка проекта;
- Защита от снятия компонента с производства.



#### Как с нами связаться

**Телефон:** 8 (812) 309 58 32 (многоканальный)

**Факс:** 8 (812) 320-02-42

**Электронная почта:** [org@eplast1.ru](mailto:org@eplast1.ru)

**Адрес:** 198099, г. Санкт-Петербург, ул. Калинина, дом 2, корпус 4, литера А.