

Small Signal Product

Thyristors

FEATURES

- Epitaxial planar die construction
- Moisture sensitivity level 1
- Matte Tin (Sn) lead finish with Nickel (Ni) underplate
- Packing code with suffix "G" means Green compound (Halogen free)



TO-92



MECHANICAL DATA

- Case : TO-92 plastic package
- Terminal : Matte tin plated, lead free, solderable per MIL-STD-202, method 208 guaranteed
- High temperature soldering guaranteed : 260°C/10s
- Weight : 0.19 gram (approximately)



MAXIMUM RATINGS AND ELECTRICAL CHARACTERISTICS (T _A =25°C unless otherwise noted)			
PARAMETER	SYMBOL	VALUE	UNIT
Forward Current RMS (All Conduction Angles)	I _{T(RMS)}	0.8	A
Peak Repetitive Forward and Reverse Blocking Voltage (T _J =25°C to 125°C, R _{GK} =1KΩ)	MCR100-3	100	V
	MCR100-4	200	
	MCR100-5	300	
	MCR100-6	400	
	MCR100-7	500	
MCR100-8	600		
Peak Forward Surge Current (T _A =25°C (1/2 Cycle, Sine Wave, 60Hz))	I _{TSM}	10	A
Circuit Fusing Considerations (t = 8.3 ms)	I ² t	0.415	A ² s
Forward Peak Gate Power (T _A =25°C, PW ≤ 1 μs)	P _{GM}	0.1	W
Forward Average Gate Power (T _A =25°C)	P _{GF(AV)}	0.01	W
Forward Peak Gate Current (T _A =25°C, PW ≤ 1 μs)	I _{GFM}	1	A
Reverse Peak Gate Current (T _A =25°C, PW ≤ 1 μs)	V _{GRM}	5	V
Operating junction temperature range	T _J	-40 ~ +125	°C
Storage temperature range	T _{STG}	-40 ~ +150	°C

Notes: 1. Valid provided that electrodes are kept at ambient temperature

PARAMETER	SYMBOL	MIN	MAX	UNIT
Peak Forward or Reverse Blocking Current at V _{AK} = Rated V _{DRM} or V _{RPM}	I _{DRM} I _{RPM}	-	10	μA
Peak Forward On-State Voltage at I _{TM} =1A Peak, T _A =25°C	V _{TM}	-	1.7	V
Gate Trigger Current (Continuous dc) at Anode Voltage = 7 Vdc., R _L =100Ω	I _{GT}	-	200	μA
Gate Trigger Current (Continuous dc) at Anode Voltage = 7 Vdc., R _L =100Ω at Anode Voltage = Rated V _{DRM} , R _L =100Ω)	V _{GT}	-	0.8	V
Holding Current at Anode Voltage =7 Vdc, Initiating Current=20mA	I _H	-	5	mA

Small Signal Product

RATINGS AND CHARACTERISTICS CURVES

($T_A=25^\circ\text{C}$ unless otherwise noted)

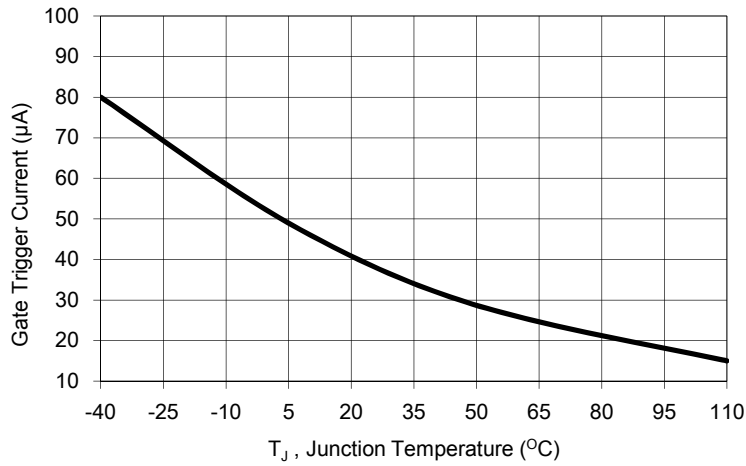

Fig. 1 Typical Gate Trigger Current VS. Junction Temperature

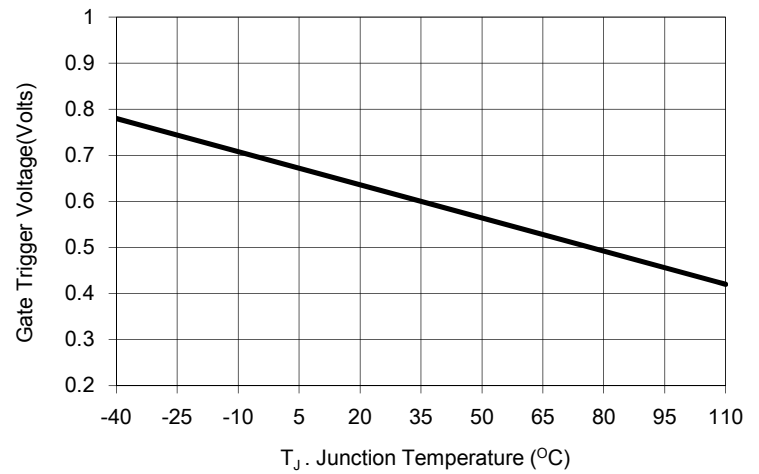

Fig. 2 Typical Gate Trigger Voltage VS. Junction Temperature

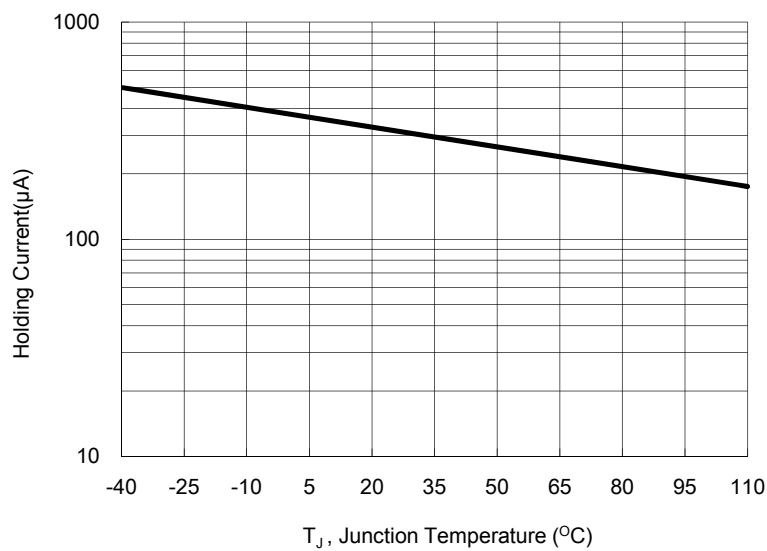

Fig. 3 Typical Holding Current VS. Junction Temperature

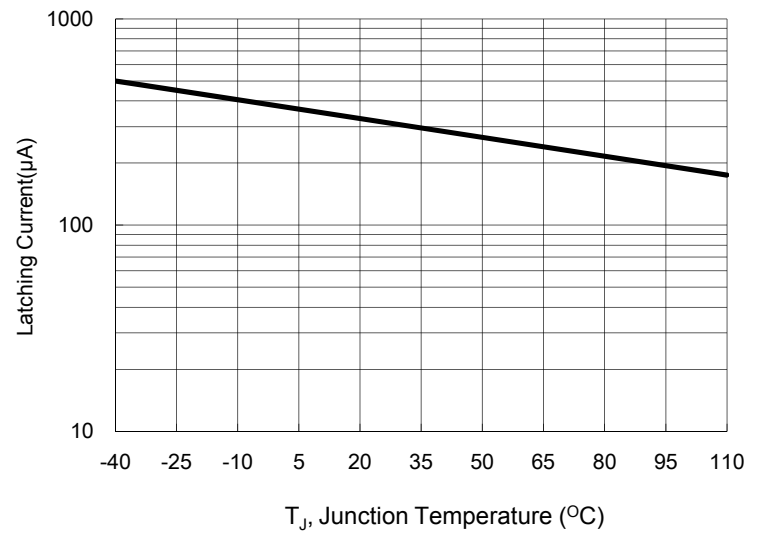

Fig. 4 Typical Latching Current VS. Junction Temperature

Fig. 5 Typical RMS Current Derating

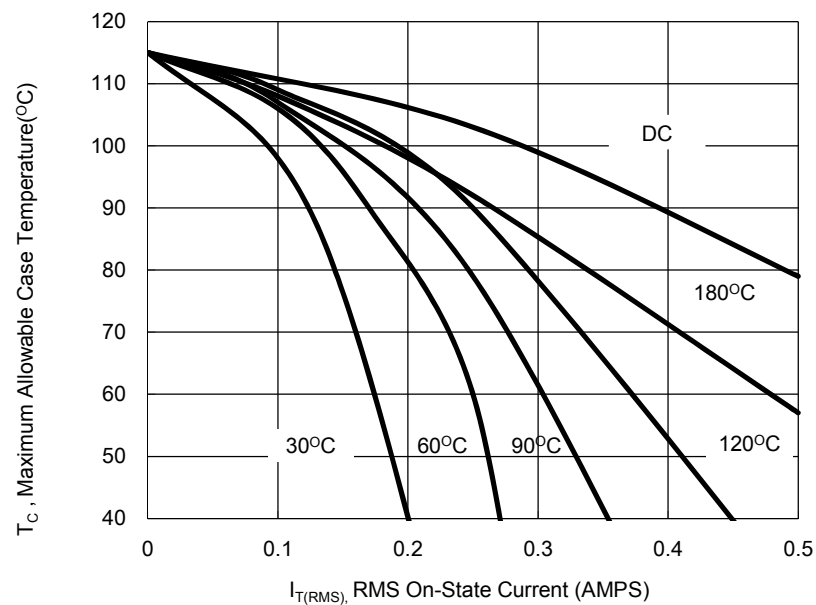
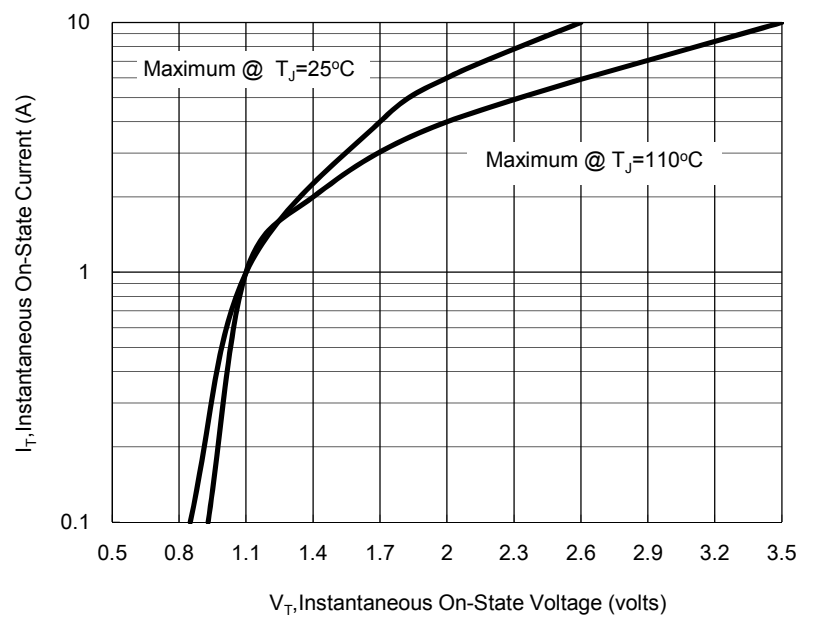

Fig. 6 Typical On-State Characteristics



Small Signal Product

ORDER INFORMATION (EXAMPLE)

MCR100-3 A1G

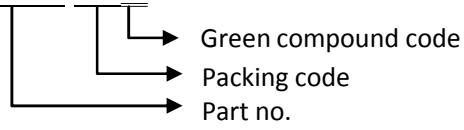

PACKAGE OUTLINE DIMENSIONS

TO-92 (Ammo)

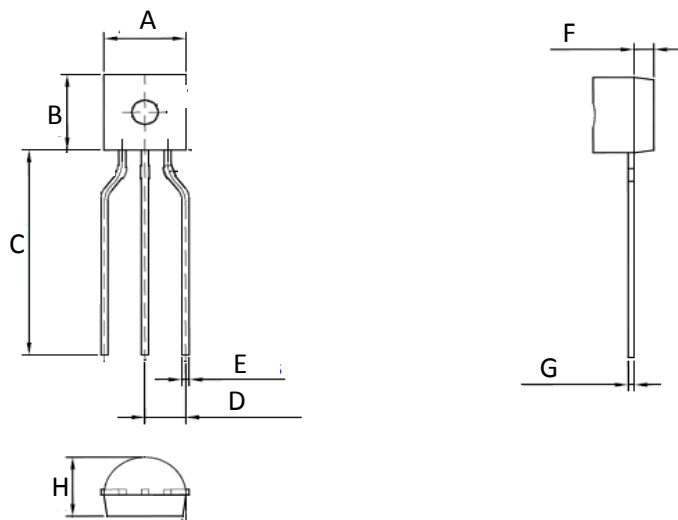

DIM.	Unit (mm)		Unit (inch)	
	Min	Max	Min	Max
A	4.30	5.10	0.169	0.201
B	4.30	4.70	0.169	0.185
C	12.50	-	0.492	-
D	2.20	2.80	0.087	0.110
E	0.35	0.55	0.014	0.022
F	0.59	1.40	0.023	0.055
G	0.29	0.51	0.011	0.020
H	3.30	4.10	0.130	0.161

TO-92 (Bulk)

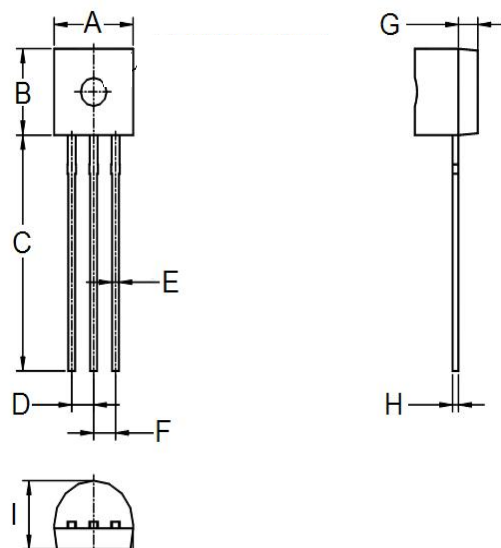

DIM.	Unit (mm)		Unit (inch)	
	Min	Max	Min	Max
A	4.30	5.10	0.169	0.201
B	4.30	4.70	0.169	0.185
C	12.50	14.50	0.492	0.571
D	1.17	1.37	0.046	0.054
E	0.35	0.55	0.014	0.022
F	1.17	1.37	0.046	0.054
G	0.59	1.40	0.023	0.055
H	0.29	0.51	0.011	0.020
I	3.30	4.10	0.130	0.161

Small Signal Product

MARKING DIAGRAM

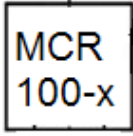

x = Device P/N from 3~8

Small Signal Product

Notice

Specifications of the products displayed herein are subject to change without notice. TSC or anyone on its behalf, assumes no responsibility or liability for any errors or inaccuracies.

Information contained herein is intended to provide a product description only. No license, express or implied, to any intellectual property rights is granted by this document. Except as provided in TSC's terms and conditions of sale for such products, TSC assumes no liability whatsoever, and disclaims any express or implied warranty, relating to sale and/or use of TSC products including liability or warranties relating to fitness for a particular purpose, merchantability, or infringement of any patent, copyright, or other intellectual property right.

The products shown herein are not designed for use in medical, life-saving, or life-sustaining applications. Customers using or selling these products for use in such applications do so at their own risk and agree to fully indemnify TSC for any damages resulting from such improper use or sale.



Компания «ЭлектроПласт» предлагает заключение долгосрочных отношений при поставках импортных электронных компонентов на взаимовыгодных условиях!

Наши преимущества:

- Оперативные поставки широкого спектра электронных компонентов отечественного и импортного производства напрямую от производителей и с крупнейших мировых складов;
- Поставка более 17-ти миллионов наименований электронных компонентов;
- Поставка сложных, дефицитных, либо снятых с производства позиций;
- Оперативные сроки поставки под заказ (от 5 рабочих дней);
- Экспресс доставка в любую точку России;
- Техническая поддержка проекта, помощь в подборе аналогов, поставка прототипов;
- Система менеджмента качества сертифицирована по Международному стандарту ISO 9001;
- Лицензия ФСБ на осуществление работ с использованием сведений, составляющих государственную тайну;
- Поставка специализированных компонентов (Xilinx, Altera, Analog Devices, Intersil, Interpoint, Microsemi, Aeroflex, Peregrine, Syfer, Eurofarad, Texas Instrument, Miteq, Cobham, E2V, MA-COM, Hittite, Mini-Circuits, General Dynamics и др.);

Помимо этого, одним из направлений компании «ЭлектроПласт» является направление «Источники питания». Мы предлагаем Вам помощь Конструкторского отдела:

- Подбор оптимального решения, техническое обоснование при выборе компонента;
- Подбор аналогов;
- Консультации по применению компонента;
- Поставка образцов и прототипов;
- Техническая поддержка проекта;
- Защита от снятия компонента с производства.



Как с нами связаться

Телефон: 8 (812) 309 58 32 (многоканальный)

Факс: 8 (812) 320-02-42

Электронная почта: org@eplast1.ru

Адрес: 198099, г. Санкт-Петербург, ул. Калинина, дом 2, корпус 4, литера А.