

NEW



Features

- Single, dual, quad-core Intel® Atom™ or Celeron® Processor System-on-Chip (SOC)
- Up to 8GB Dual Channel DDR3L at 1333MHz
- VGA and two DDI channels (optional LVDS)
- Three PCIe x1, GbE
- Two SATA 3Gb/s, one USB 3.0, seven USB 2.0
- Supports Smart Embedded Management Agent (SEMA) functions
- Extreme Rugged™ operating temperature: -40°C to +85°C (optional)

Specifications

Core System

CPU	Single, dual, quad-core Intel® Atom™ or Celeron® Processor Atom™ E3845 1.91 GHz 542/792 (Turbo) 10W (4C/1333) Atom™ E3827 1.75 GHz 542/792 (Turbo) 8W (2C/1333) Atom™ E3826 1.46 GHz 533/667 (Turbo) 7W (2C/1066) Atom™ E3825 1.33 GHz 533 (No Turbo) 6W (2C/1066) Atom™ E3815 1.46 GHz 400 (No Turbo) 5W (1C/1066) Atom™ E3805 1.33 GHz (No GFX) 3W (2C/1066) Celeron® N2930 1.83/2.16 (Burst) GHz, 313/854 (Turbo) 7.5W (4C/1333) Celeron® J1900 2.0/2.42 (Burst) GHz, 688/854 (Turbo) 10W (4C/1333)
-----	--

Supports: Single, dual or quad Out-of-Order Execution (OOE) processor cores, Intel® VT-x, Intel® SSE4.1 and SSE4.2, Intel® 64 architecture, IA 32-bit, PCLMULQDQ Instruction DRNG, Intel® Thermal Monitor (TM1 & TM2)

Note: Availability of features may vary between processor SKUs.

Memory	Dual channel non-ECC 1333/1066 MHz DDR3L memory up to 8GB in dual stacked SODIMM sockets
Embedded BIOS	AMI EFI with CMOS backup in 8MB SPI BIOS
Cache	Primary 32 KB, 8-way L1 instruction cache and 24 KB, 6-way L1 write-back data cache 2MB for E3845, N2930 and J1900 1MB for E3827, E3826, E3825 and E3805 512K for E3815
Expansion Busses	3 PCI Express x1 Gen2 (AB): lanes 0/1/2; build option PCIe x4 (lose GbE) LPC bus, SMBus (system), I ² C (user)
SEMA Board Controller	Supports: Voltage/Current monitoring, Power sequence debug support, AT/ATX mode control, Logistics and Forensic information, Flat Panel Control, General Purpose I ² C, Failsafe BIOS (dual BIOS), Watchdog Timer and Fan Control
Debug Headers	40-pin multipurpose flat cable connector Use in combination with DB-40 debug module providing BIOS POST code LED, BMC access, SPI BIOS flashing, Power test points, Debug LEDs 26-pin XDP header for ICE debug of CPU/chipset

Video

GPU Feature Support	7th generation Intel® graphics core architecture with four execution units supporting two independent displays 3D graphics hardware acceleration Supports DirectX 11, OCL 1.1, OGL ES Halt/2.0/1.1, OGL 3.2 Video decode hardware acceleration including support for H.264, MPEG2, MVC, VC-1, WMV9 and VP8 formats Video encode hardware acceleration including support for H.264, MPEG2 and MVC formats
Digital Display Interface	DDI1 supporting DisplayPort/HDMI/DVI (optional dual channel 18/24-bit LVDS support) DDI2 supporting DisplayPort/HDMI/DVI
VGA	Analog VGA supporting resolutions of up to 2560 x 1600 x 24bpp @60

Audio

Chipset	Intel® HD Audio integrated in SOC
Audio Codec	Located on carrier Express-BASE6

Ethernet

Intel® MAC/PHY Interface	Intel® i210LM (MAC/PHY) Ethernet controller 10/100/1000 GbE connection
--------------------------	---

I/O Interfaces

USB	1x USB 3.0 (USB 0) 6x USB 1.1/2.0 (USB 1/2/3/4/5/6, ports 3-6 from USB hub)
SATA	Two SATA 3 Gb/s ports
Serial	2 UART ports COM 0/1 (COM 0 support console redirection)
eMMC	Optional soldered on module bootable eMMC flash storage 8 to 32 GB
SDIO	On module mini SD card socket, eMMC feature may vary between OS
GPIO	4 GPO and 4 GPI

Super I/O

On carrier if needed (standard support for W83627DHG-P)

TPM

Chipset	Atmel AT97SC3204 (optional)
Type	TPM 1.2

Power

Standard Input	ATX = 12V±5% / 5Vsb ±5% or AT = 12V±5%
Wide Input	ATX = 5-20 V / 5Vsb ±5% or AT = 5 -20V
Management	ACPI 4.0 compliant, Smart Battery support
Power States	C0, C1, C1E, C4, C6 S0, S3, S4, S5 (Wake on USB S3 for port 0~7/S4 for port 0~3, WOL S3/S4/S5)
ECO mode	Wake on USB S3/S4, WOL S3/S4/S5

Mechanical and Environmental

Specification	PICMG COM.0: Rev 2.1 Type 6
Form Factor	Compact size: 95 mm x 95 mm
Operating Temperature	Standard: 0°C to +60°C Extreme Rugged™: -40°C to +85°C (optional, Atom™ E38xx series only)
Humidity	5-90% RH operating, non-condensing 5-95% RH storage (and operating with conformal coating)
Shock and Vibration	IEC 60068-2-64 and IEC-60068-2-27 MIL-STD-202F, Method 213B, Table 213-I, Condition A and Method 214A, Table 214-I, Condition D
HALT	Thermal Stress, Vibration Stress, Thermal Shock and Combined Test

Operating Systems

Standard Support	Windows 7/8 32/64-bit, Linux 32/64-bit
Extended Support (BSP)	WES7/8, Linux, VxWorks 32/64-bit WEC7 32-bit

Functional Diagram

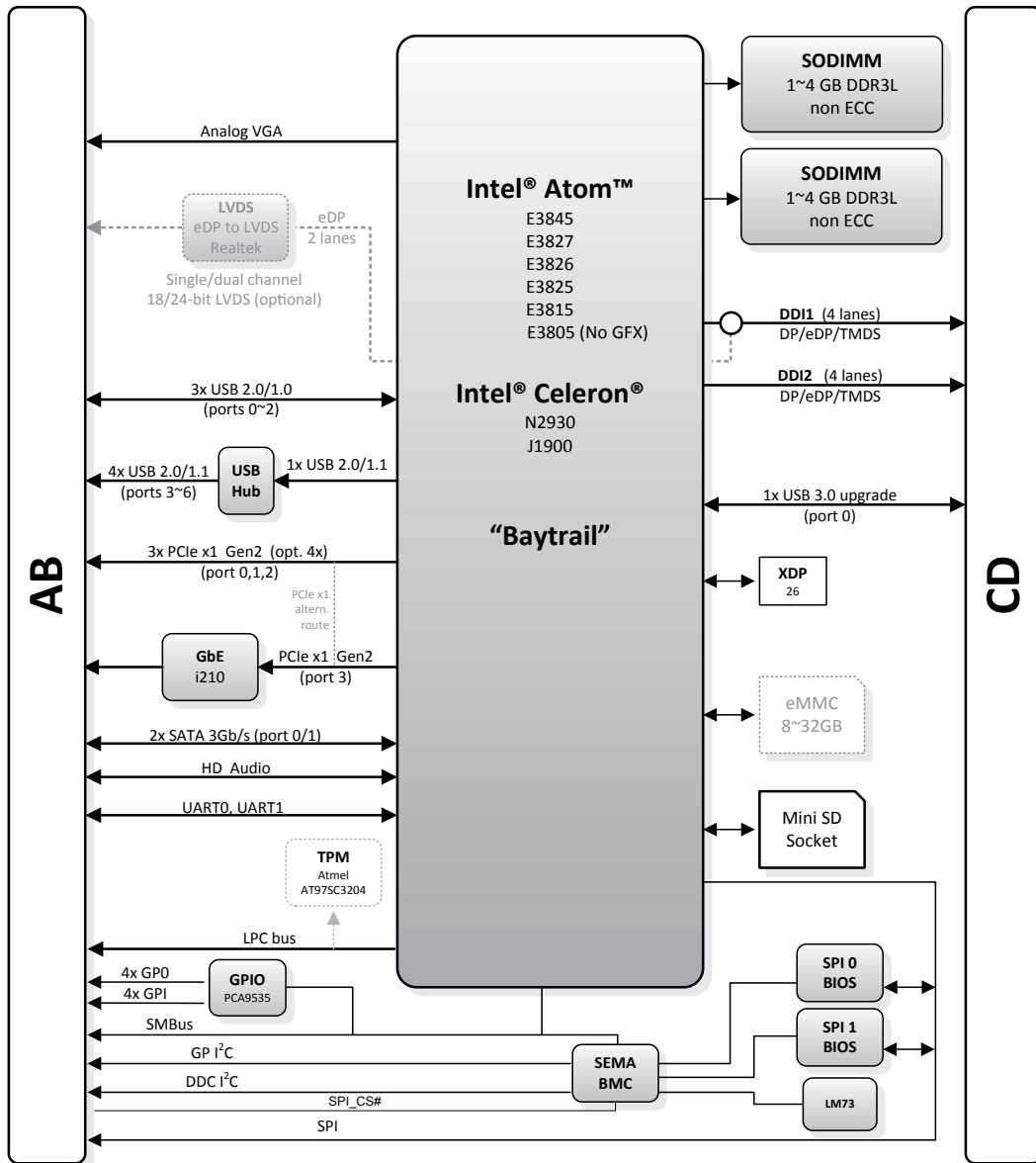

Ordering Information

Modules

Model Number	Description/Configuration
cExpress-BT-E3845	Compact COM Express® Type 6 Module with Intel® Atom™ E3845 at 1.91 GHz
cExpress-BT-E3827	Compact COM Express® Type 6 Module with Intel® Atom™ E3827 at 1.75 GHz
cExpress-BT-E3826	Compact COM Express® Type 6 Module with Intel® Atom™ E3826 at 1.46 GHz
cExpress-BT-E3825	Compact COM Express® Type 6 Module with Intel® Atom™ E3825 at 1.33 GHz
cExpress-BT-E3815	Compact COM Express® Type 6 Module with Intel® Atom™ E3815 at 1.46 GHz
cExpress-BT-E3805	Compact COM Express Type6 Module with Intel Atom E3805 at 1.33 GHz
cExpress-BT-J1900	Compact COM Express® Type 6 Module with Intel® Celeron® J1900 at 2.00 GHz
cExpress-BT-N2930	Compact COM Express® Type 6 Module with Intel® Celeron® N2930 at 1.83 GHz

Accessories

Model Number	Description/Configuration
Heat Spreaders	
HTS-cBT-B	Heatspreader for cExpress-BT with threaded standoffs for bottom mounting
HTS-cBT-BT	Heatspreader for cExpress-BT with through hole standoffs for top mounting
Passive Heatsinks	
THS-cBT-B	Low profile heatsink for cExpress-BT with threaded standoffs for bottom mounting
THSH-cBT-B	High profile heatsink for cExpress-BT with threaded standoffs for bottom mounting
Active Heatsink	
THSF-cBT-B	High profile heatsink with Fan for cExpress-BT with threaded standoffs for bottom mounting (-40°C to + 85°C operation)
Starter Kit	
Starter kit plus	Starter kit plus for cExpress-BT



Компания «ЭлектроПласт» предлагает заключение долгосрочных отношений при поставках импортных электронных компонентов на взаимовыгодных условиях!

Наши преимущества:

- Оперативные поставки широкого спектра электронных компонентов отечественного и импортного производства напрямую от производителей и с крупнейших мировых складов;
- Поставка более 17-ти миллионов наименований электронных компонентов;
- Поставка сложных, дефицитных, либо снятых с производства позиций;
- Оперативные сроки поставки под заказ (от 5 рабочих дней);
- Экспресс доставка в любую точку России;
- Техническая поддержка проекта, помощь в подборе аналогов, поставка прототипов;
- Система менеджмента качества сертифицирована по Международному стандарту ISO 9001;
- Лицензия ФСБ на осуществление работ с использованием сведений, составляющих государственную тайну;
- Поставка специализированных компонентов (Xilinx, Altera, Analog Devices, Intersil, Interpoint, Microsemi, Aeroflex, Peregrine, Syfer, Eurofarad, Texas Instrument, Miteq, Cobham, E2V, MA-COM, Hittite, Mini-Circuits, General Dynamics и др.);

Помимо этого, одним из направлений компании «ЭлектроПласт» является направление «Источники питания». Мы предлагаем Вам помощь Конструкторского отдела:

- Подбор оптимального решения, техническое обоснование при выборе компонента;
- Подбор аналогов;
- Консультации по применению компонента;
- Поставка образцов и прототипов;
- Техническая поддержка проекта;
- Защита от снятия компонента с производства.



Как с нами связаться

Телефон: 8 (812) 309 58 32 (многоканальный)

Факс: 8 (812) 320-02-42

Электронная почта: org@eplast1.ru

Адрес: 198099, г. Санкт-Петербург, ул. Калинина, дом 2, корпус 4, литера А.