

## Features

- Extremely Low Parasitic Capacitance and Inductance
- Surface Mountable in Microwave Circuits, No Wirebonds Required
- Rugged HMIC Construction with Polyimide Scratch Protection
- Reliable, Multilayer Metalization with a Diffusion Barrier, 100% Stabilization Bake (300°C, 16 hours)
- Lower Susceptibility to ESD Damage

## Description

The MA4E2532-1113 Series SURMOUNT™ Low and Medium Barrier, Silicon Schottky Ring Quad Diodes are fabricated with the patented Heterolithic Microwave Integrated Circuit (HMIC) process. HMIC circuits consist of Silicon pedestals which form diodes or via conductors embedded in a glass dielectric, which acts as the low dispersion, low loss, microstrip transmission medium. The combination of silicon and glass allows HMIC devices to have excellent loss and power dissipation characteristics in a low profile, reliable device.

The Surmount Schottky devices are excellent choices for circuits requiring the small parasitics of a beam lead device coupled with the superior mechanical performance of a chip. The Surmount structure employs very low resistance silicon vias to connect the Schottky contacts to the metalized mounting pads on the bottom surface of the chip. These devices are reliable, repeatable, and a lower cost performance solution to conventional devices. They have lower susceptibility to electrostatic discharge than conventional beam lead Schottky diodes.

The multi-layer metallization employed in the fabrication of the Surmount Schottky junctions includes a platinum diffusion barrier, which permits all devices to be subjected to a 16-hour non-operating stabilization bake at 300°C.

The "0505" outline allows for Surface Mount placement and multi-functional polarity orientations.

## Case Style 1113

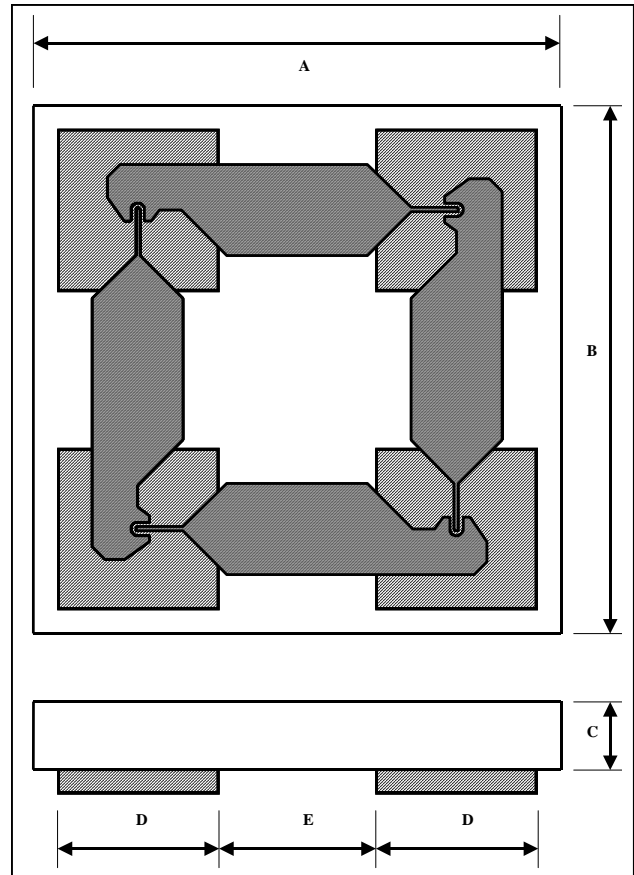

## Case Style 1113

DIM	INCHES		MILLIMETERS	
	MIN.	MAX.	MIN.	MAX.
A	0.0445	0.0465	1.130	1.180
B	0.0445	0.0465	1.130	1.180
C	0.0040	0.0080	0.102	0.203
D Sq.	0.0128	0.0148	0.325	0.375
E	0.0128	0.0148	0.325	0.375

## Electrical Specifications @ 25°C (Measured as Single Diodes)

Model Number	Type	Recommended Freq. Range	Vf @ 1 mA (mV)	Δ Vf @ 1 mA (mV)	Ct @ 0 V (pF)	Rt Slope Resistance (Vf1-Vf2) / (10.5 mA - 9.5 mA) (Ω)
MA4E2532L-1113	Low Barrier	DC - 18 GHz	330 Max. 300 Typ.	10 Max.	0.16 Max. 0.10 Typ.	16 Typ. 20 Max.
MA4E2532M-1113	Medium Barrier	DC - 18 GHz	470 Max. 440 Typ.	10 Max.	0.18 Max. 0.12 Typ.	10 Typ. 18 Max.

1. Rt is the dynamic slope resistance where  $R_t = R_s + R_j$  where  $R_j = 26 / I_{dc}$  ( $I_{dc}$  is in mA) and  $R_s$  is the Ohmic Resistance.

## Applications

The MA4E2532-1113 Series SURMOUNT™ Low and Medium Barrier Silicon Schottky Ring Quad Diodes are recommended for use in microwave circuits through Ku band frequencies for lower power applications such as mixers, sub-harmonic mixers, detectors and limiters. The HMIC construction facilitates the direct replacement of more fragile beam lead diodes with the corresponding Surmount diode, which can be connected to a hard or soft substrate circuit with solder.

## Handling

All semiconductor chips should be handled with care to avoid damage or contamination from perspiration and skin oils. The use of plastic tipped tweezers or vacuum pickups is strongly recommended for individual components. The top surface of the die has a protective polyimide coating to minimize damage.

The rugged construction of these Surmount devices allows the use of standard handling and die attach techniques. It is important to note that industry standard electrostatic discharge (ESD) control is required at all times, due to the sensitive nature of Schottky junctions. Bulk handling should insure that abrasion and mechanical shock are minimized.

## Die Bonding

Die attach for these devices is made simple through the use of surface mount die attach technology. Mounting pads are conveniently located on the bottom surface of these devices, and are opposite for the active junction. The devices are well suited for high temperature solder attachment onto hard substrates. 80Au/20Sn and Sn63/Pb36/Ag2 solders are acceptable for usage.

For Hard substrates, we recommend utilizing a vacuum tip and force of 60 to 100 grams applied uniformly to the top surface of the device, using a hot gas bonder with equal heat applied across the bottom mounting pads of the device. When soldering to soft substrates it is recommended to use a lead-tin interface at the circuit board mounting pads. Position the die so that its mounting pads are aligned with the circuit board mounting pads. Reflow the solder paste by applying equal heat to the circuit at both die-mounting pads. The solder joint must Not be made one at a time, creating unequal heat flow and thermal stress. Solder reflow should Not be performed by causing heat to flow through the top surface of the die. Since the HMIC glass is transparent, the edges of the mounting pads can be visually inspected through the die after die attach is completed.

## MA4E2532L-1113 Low Barrier SPICE PARAMETERS

Is (nA)	Rs (Ω)	N	Cj0 (pF)	M	Ik (mA)	Cjpar (pF)	Vj (V)	FC	BV (V)	IBV (mA)
26	12.8	1.20	1.0 E-2	0.5	14	9.0 E-2	8.0 E-2	0.5	5.0	1.0 E-2

## MA4E2532M-1113 Medium Barrier SPICE PARAMETERS (Per Diode)\*

Is (nA)	Rs (Ω)	N	Cj0 (pF)	M	Ik (mA)	Cjpar (pF)	Vj (V)	FC	BV (V)	IBV (mA)
5 E-1	9.6	1.20	1.0 E-2	0.5	10	9.0 E-2	8.0 E-2	0.5	5.0	1.0 E-2

Spice Parameters (Per Diode) are based on the MA4E2502 Series datasheet.

## Circuit Mounting Dimensions (Inches)

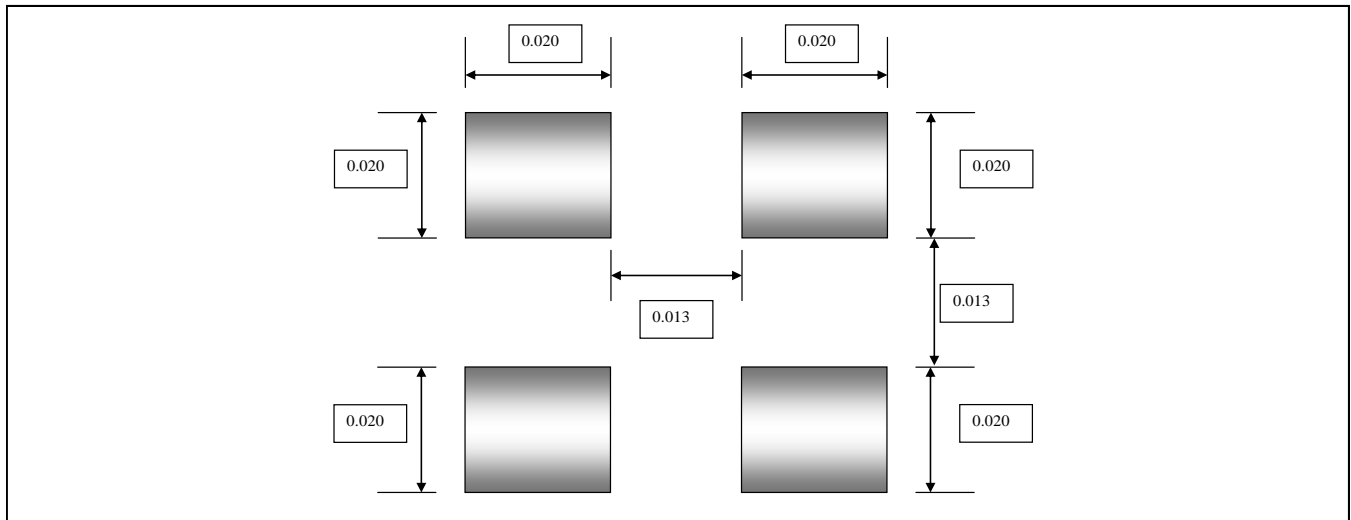

## Ordering Information

Part Number	Packaging
MA4E2532L-1113W	Wafer on Frame
MA4E2532L-1113	Die in Carrier
MA4E2532L-1113T	Tape/Reel
MA4E2532M-1113W	Wafer on Frame
MA4E2532M-1113	Die in Carrier
MA4E2532M-1113T	Tape/Reel

## Absolute Maximum Ratings <sup>1</sup>

Parameter	Value
Operating Temperature	-40°C to +150°C
Storage Temperature	-40°C to +150°C
Junction Temperature	+175°C
Forward Current	20 mA
Reverse Voltage (10 uA)	5 V
RC C.W. Incident Power	+20 dBm
RF & DC Dissipated Power	50 mW
Electrostatic Discharge (ESD) Classification <sup>2</sup>	Class 0

1. Exceeding any of these values may result in permanent damage.

2. Human Body Model

## Schematic

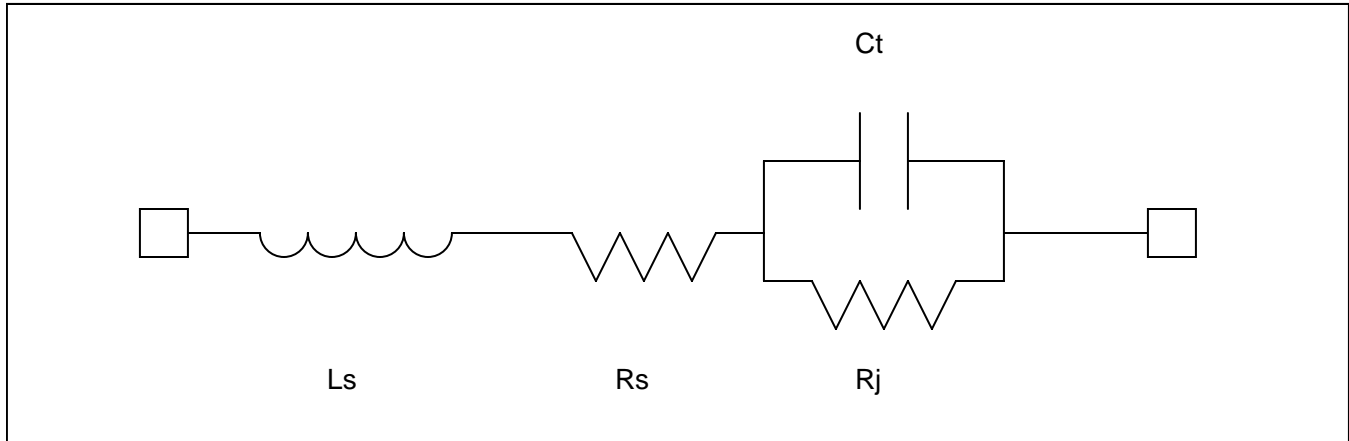

## Average Schematic Values per Diode

Model Number	Ls (nH)	Rs ( $\Omega$ )	Rj ( $\Omega$ )	Ct (pF)
MA4E2532L-1113	0.8	13.4	26 / Idc	0.10
MA4E2532M-1113	0.8	9.4	26 / Idc	0.12

## MA4E2532L-1113, MA4E2532M-1113 Equivalent Circuit

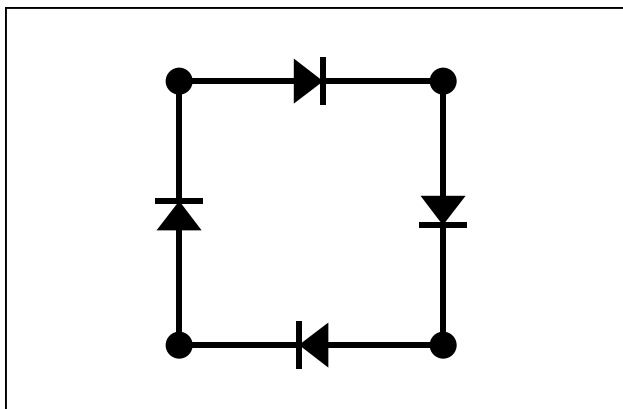



Компания «ЭлектроПласт» предлагает заключение долгосрочных отношений при поставках импортных электронных компонентов на взаимовыгодных условиях!

Наши преимущества:

- Оперативные поставки широкого спектра электронных компонентов отечественного и импортного производства напрямую от производителей и с крупнейших мировых складов;
- Поставка более 17-ти миллионов наименований электронных компонентов;
- Поставка сложных, дефицитных, либо снятых с производства позиций;
- Оперативные сроки поставки под заказ (от 5 рабочих дней);
- Экспресс доставка в любую точку России;
- Техническая поддержка проекта, помощь в подборе аналогов, поставка прототипов;
- Система менеджмента качества сертифицирована по Международному стандарту ISO 9001;
- Лицензия ФСБ на осуществление работ с использованием сведений, составляющих государственную тайну;
- Поставка специализированных компонентов (Xilinx, Altera, Analog Devices, Intersil, Interpoint, Microsemi, Aeroflex, Peregrine, Syfer, Eurofarad, Texas Instrument, Miteq, Cobham, E2V, MA-COM, Hittite, Mini-Circuits, General Dynamics и др.);

Помимо этого, одним из направлений компании «ЭлектроПласт» является направление «Источники питания». Мы предлагаем Вам помощь Конструкторского отдела:

- Подбор оптимального решения, техническое обоснование при выборе компонента;
- Подбор аналогов;
- Консультации по применению компонента;
- Поставка образцов и прототипов;
- Техническая поддержка проекта;
- Защита от снятия компонента с производства.



#### Как с нами связаться

**Телефон:** 8 (812) 309 58 32 (многоканальный)

**Факс:** 8 (812) 320-02-42

**Электронная почта:** [org@eplast1.ru](mailto:org@eplast1.ru)

**Адрес:** 198099, г. Санкт-Петербург, ул. Калинина, дом 2, корпус 4, литера А.